



SERVICE BULLETIN

2300 Madison Highway Valdosta, GA 31601

CATEGORY 2

This Service Bulletin contains information pertaining to a threat to the continued safe operation of an aircraft or to the safety of persons or property on the ground unless some specific action is taken by the aircraft owner.

SB-194

ATA 2710

DATE: August 1, 2011

SUBJECT: **CONTROL COLUMN BEARING LUBRICATION**

MODEL / SERIALS AFFECTED: AG-5B 10201 through 10251

TIME OF COMPLIANCE: Within the next 100 hours time in service or at the next scheduled inspection, whichever occurs first.

GENERAL:

We have received a report of aileron control binding caused by failure of one or more of the four RAX718 Thrust Bearings installed in the 5602104-504 Control Wheel Column Assembly. The cause of the bearing failure was determined to be the absence of lubrication in the bearing. It is suspected that there may be additional aircraft in the above serial number range that had the RAX718 bearings installed without lubrication during the manufacturing process. If left undetected and not corrected, this condition could lead to the binding of the bearings and loss of aileron control, resulting in possible loss of controlled flight.

INSPECTION:

Inspect the 5602104-504 Control Wheel Column Assembly as follows:

A. Gain access to the "T" column.

- (1) Disconnect the aircraft Battery/s
- (2) Remove the Pilot and Co-Pilot Seat.
- (3) Remove the Glare Shield.

B. Thrust Bearing Removal (Ref. Figure 1 and Tiger Aircraft AG-5B Maintenance Manual Chapter 27)

- (1) Loosen turnbuckle (5) and remove chain (15) from sprockets (2) and (3).
- (2) Remove nut, washer, and bolt (11) and remove spacer (10) then slide universal (9) aft until the universal is clear of the "T" column.

- (3) Grasp sprocket (3) and pull shaft (12) from control column (1). Shims (13) and thrust plate (17) will separate from the shaft.
- (4) Remove thrust plate (17) and spacer (10) from shaft (12).
- (5) Pull thrust bearings (16) from control column (1).
- (6) Repeat this procedure for the opposite side.

C. Thrust Bearing (P/N RAX718) Inspection

WARNING: **USE SOLVENTS IN A WELL VENTILATED AREA. AVOID BREATHING FUMES. KEEP AWAY FROM FLAMES.**

- (1) Inspect the bearings for the presents of grease. If the bearing are dry (no grease), install new RAX718 bearings and new shaft (12) P/N 5603069-1 as described in (D.) below.
- (2) If grease is present, use mineral spirits, to wash all grease from the needle and thrust bearings.
- (2) Inspect bearings for excessive wear, damage and freedom of movement. Replace if defective.
- (3) Use a clean lint free cloth saturated with mineral spirits to remove grease and foreign material from the bearing races.
- (4) Inspect the races for excessive wear or damage and replace if defective.
- (5) Pack the thrust bearings with MIL-PRF-81332 grease.

D. Reassemble “T” Column (Reference FIGURE 1)

- (1) Place spacers (10) and thrust plate (17) on shaft (12).
- (2) Install thrust bearings (16) in control column.
- (3) Slide shaft (12) through thrust bearings (16) and install thrust plate (17), shims (10), and collar (19) on shaft (12). Align holes in collar (19) and shaft (12).
- (4) Place spacers (10) in end of universal (9) such that holes align, then insert universal (9) into the end of shaft (12).
- (5) Align holes in universal (9) and shaft (12) and secure with bolt, washers, and nuts (11). Torque to standard value per Chapter 91 of the AG-5B Maintenance Manual.
- (6) Use a clean, lint-free cloth saturated with mineral spirits to wipe all foreign material from the chain and sprockets.
- (7) Lubricate the chain with a light coat of MIL-PRF-81332 grease.
- (8) Install and align chain (15) as follows:
 - (a) Clamp a straight piece of wood across the top of both control wheels to lock them at their neutral positions.
 - (b) Position bellcrank (20) so that it is horizontal.

- (c) Route chain (15) around the two upper sprockets (2 & 3) such that the turnbuckle (5) is over the large sprocket (8) and such that turnbuckle (6) is approximately half-way between sprockets (3) and (8).
- (d) Route chain (15) over sprocket (8), under and around (4) and to sprocket (2).
- (e) Adjust turnbuckle (5) to take up slack in chain between two upper sprockets (2 & 3).
- (f) Adjust turnbuckles (6) and (7) to take up remaining slack in chain.
- (h) Tighten all three turnbuckles until chain tension is such that a 2-pound force applied to the chain at point (15) will cause a 1/4 inch deflection in the chain, and bellcrank (20) is horizontal when both control wheels are at their neutral position.
- (i) Safety wire turnbuckles, with 0.032" safety wire or locking clips.

E. REQUIRED ACTION

1. Record compliance with this Service Bulletin in the aircraft log book.
2. Email compliance notification to: customerservice@trueflightaerospace.com. Include aircraft serial number, registration number, time in service and condition of the RAX718 Thrust Bearings.

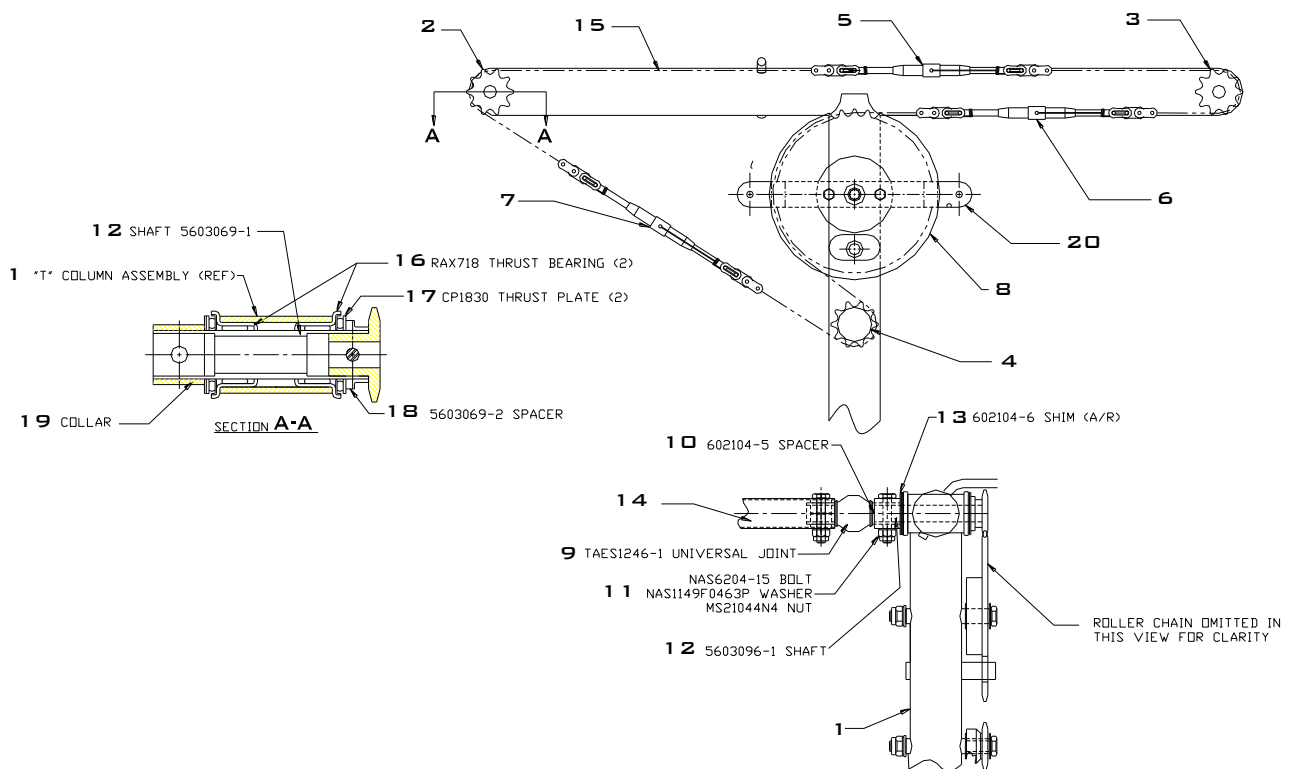

FIGURE 1

True Flight Aerospace, LLC
 2300 Madison Highway
 Valdosta, GA 31601

Phone: 229-242-6337
 Fax: 229-242-6344