



15656 Highway 84 Quitman, GA 31643 229-263-4205

CRITICAL SERVICE BULLETIN

CATEGORY 2

Contains information pertaining to a threat to the continued safe operation of an aircraft or to the safety of persons or property on the ground unless some specific action is taken by the aircraft owner.

SB-192
ATA 5310

DATE: August 20, 2009

SUBJECT: **AFT FUSELAGE INSPECTION**

MODEL / SERIALS AFFECTED: AA5 All

TIME OF COMPLIANCE: Within the next 100 hours time in service or at the next scheduled inspection, whichever comes first and at each annual inspection thereafter or after a hard landing, tail strike or any other notable impact or force to tail area.

GENERAL:

It has been discovered through routine maintenance that several AA5 aircraft have damage to structure in the aft fuselage including the horizontal stabilizer forward spar attachment structure, spar support angles, and stiffeners (Figure 1-3). It is suspected that this damage was the result of asymmetric forces applied to one side of the horizontal stabilizer, twisting and/or bowing the fuselage during ground handling. This damage, left undetected, could compromise the structural integrity of the aft fuselage which may result in loss of controlled flight.

INSPECTION:

1. Remove the access covers below the Vertical Stabilizer. (Figure 1)
2. Remove the ELT and the ELT mount bracket to provide access to the aft fuselage structure through the lightening holes in the horizontal bulkhead. (Figure 2)

Note: Removal of the horizontal stabilizer and horizontal bulkhead would improve access to this area.

3. Remove the forward horizontal stabilizer spar attach bolts. (Figure 3)

- 4 Using a suitable light and a mirror, inspect all of the aft fuselage structure including all vertical and horizontal stiffeners for cracks, bends, buckles, delamination and other damage.
- 5 Inspect the forward horizontal stabilizer attach bolt holes for cracks radiating from the holes and security of the nutplate.

REQUIRED ACTION

1. If no damage is found, reinstall the horizontal stabilizer attach bolts, the ELT bracket and the ELT. Reinstall the access panels and enter compliance with this Service Bulletin in the aircraft log book.
2. If damage to any structural member is found, make appropriate repairs in accordance with the Gulfstream Aerospace Corporation AA5 Series Maintenance Manual, Grumman American Service Kit 125A or AC43-13-1B.
3. Make the appropriate aircraft log book entries.

CAUTION: To prevent future damage to the aft fuselage, **DO NOT** move the aircraft by pushing or pressing down on the horizontal stabilizer.

True Flight Aerospace, LLC
16565 Highway 84
Quitman, GA 31643

Phone: 229-263-4205
Fax: 229-263-4210

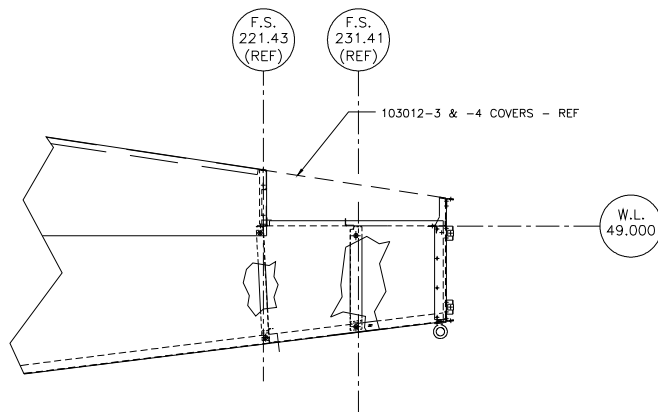

FIGURE 1



FIGURE 2
Vertical Stabilizer Removed

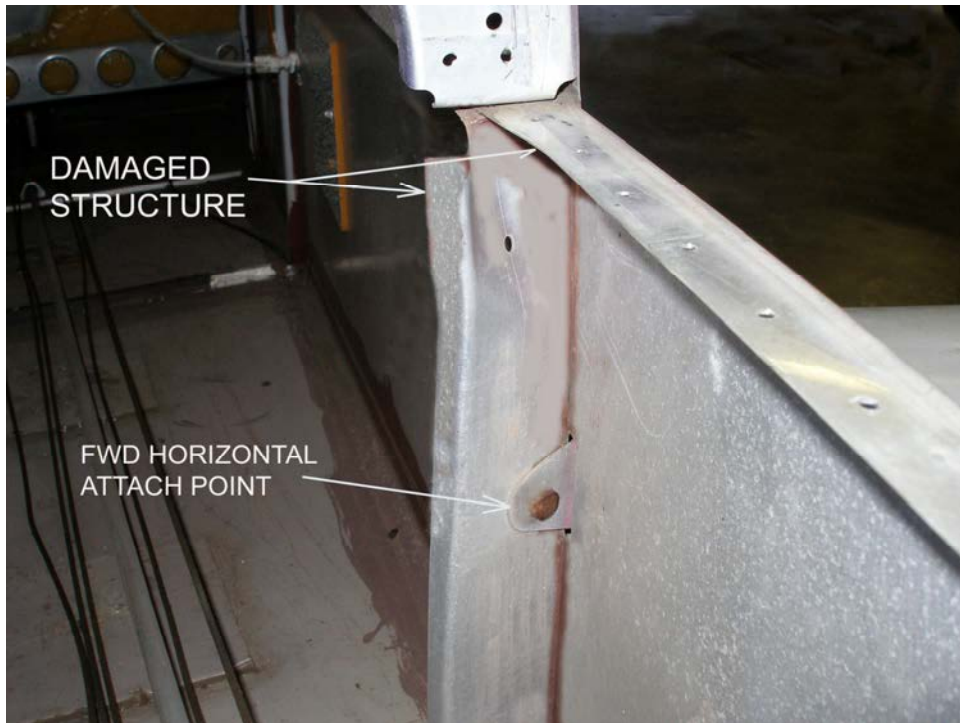

FIGURE 3
Horizontal Bulkhead Removed
Note damage to right vertical support

