

# PILOT'S OPERATING HANDBOOK

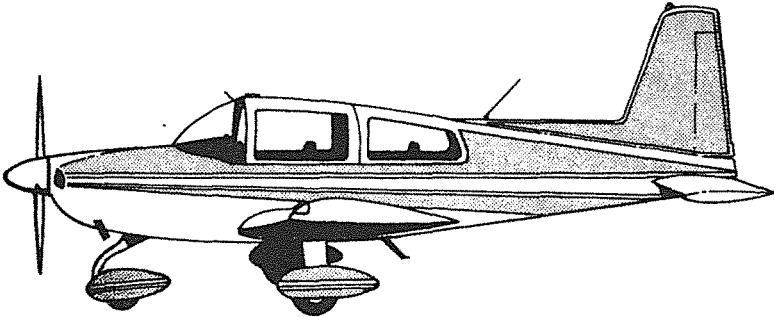

## Model AA-5B TIGER

1977/1978/1979

THIS HANDBOOK INCLUDES THE MATERIAL REQUIRED TO BE FURNISHED TO THE PILOT BY FAR PART 23.

SERIAL NO. 1145  
REGISTRATION NO. 4529 D

GULFSTREAM AEROSPACE CORPORATION  
SAVANNAH, GEORGIA, U.S.A.

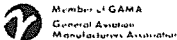

©

Issued: September 30, 1976  
Revision 4, Revised May 12, 1983

©

Copyright 1979

All rights reserved, including the right to reproduce this publication. No part may be reproduced, stored in any retrieval system, or transmitted in any part or form or by any means, electronic, photocopying, microfilm, microfiche, mechanical, or otherwise, without prior written permission of Gulfstream American.

GULFSTREAM AEROSPACE  
MODEL AA-5B TIGER

LIST OF EFFECTIVE PAGES

Dates of issue for original and revised pages are:

Original...0...September 30, 1976

Revision...1...December 15, 1977

Revision...2...July 15, 1978

Revision...3...February 15, 1979

Revision...4...May 12, 1983

THE TOTAL NUMBER OF PAGES IN THIS HANDBOOK IS 176 CONSISTING OF THE FOLLOWING. THIS INCLUDES THE SUPPLEMENTS PROVIDED IN SECTION 9 WHICH COVER OPTIONAL SYSTEMS AVAILABLE IN THE AIRPLANE.

Page No.	*Revision No.	Page No.	*Revision No.
Title.....	4	3-18.....	1
A.....	4	3-19.....	0
B.....	4	3-20 Blank.....	0
i.....	3	4-1 and 4-2.....	0
ii thru iii.....	0	4-3.....	3
iv.....	3	4-4.....	2
1-1.....	0	4-5 thru 4-9.....	1
1-2.....	2	4-10.....	0
1-3.....	4	4-11.....	1
1-4.....	2	4-12.....	0
1-5 thru 1-12.....	0	4-13.....	1
2-1.....	0	4-14 thru 4-21.....	0
2-2 Blank.....	0	4-22.....	1
2-3.....	3	4-23.....	0
2-4.....	0	4-24.....	1
2-5.....	4	4-25.....	0
2-6.....	0	4-26 Blank.....	0
2-7.....	2	5-1.....	0
2-8.....	0	5-2 Blank.....	0
2-9 thru 2-12.....	1	5-3 thru 5-14.....	0
3-1 thru 3-4.....	0	5-15 thru 5-17.....	2
3-5.....	2	5-18.....	0
3-6 thru 3-10.....	0	5-19 thru 5-21.....	2
3-11.....	2	5-22 and 5-23.....	0
3-12.....	0	5-24.....	1
3-13.....	2	5-25.....	0
3-14 thru 3-17.....	0	5-26.....	1

\*Zero in this column indicates an original page.

Revised: May 12, 1983

GULFSTREAM AEROSPACE  
MODEL AA-5B TIGER

LIST OF EFFECTIVE PAGES

Page No.	*Revision No.
5-27 and 5-28.....	0
6-1.....	0
6-2 Blank.....	0
6-3 thru 6-15.....	0
6-16.....	3
6-17.....	0
6-18.....	1
6-19.....	1
6-20 Blank.....	0
7-1 thru 7-4.....	0
7-5.....	1
7-6 thru 7-11.....	0
7-12.....	2
7-13.....	4
7-14.....	2
7-15.....	0
7-16 and 7-16a.....	1
7-16b Blank.....	1
7-17 thru 7-24.....	0
8-1.....	0
8-2 Blank.....	0
8-3 thru 8-5.....	3
8-6 thru 8-10.....	0
8-11.....	2
8-12.....	1
8-13 and 8-14.....	0
9-1.....	0
9-2 Blank.....	0
9-3.....	0
9-4 Blank.....	0
10-1 and 10-2.....	0
10-3.....	3
10-4 thru 10-14.....	0
10-15.....	2
10-16.....	0

\*Zero in this column indicates an original page.

Revised: May 12, 1983

**GULFSTREAM AMERICAN  
MODEL AA-5B TIGER**

**WELCOME ABOARD**

**WELCOME ABOARD!**

Your AA-5B Tiger has been designed and constructed to provide you with a responsive four-place airplane to serve your needs for either pleasure or business flying in both comfort and economy.

This handbook has been prepared to help you obtain the maximum pleasure and utility from your airplane. Read it carefully, review it frequently, and keep it with you in the airplane at all times.

With proper operational techniques and good maintenance, your Gulfstream American Tiger should serve you well. Get to know your Gulfstream American Dealer. He is equipped to provide any assistance that may be required.

## PERFORMANCE-SPECIFICATIONS\*

### SPEED:

Maximum at Sea Level . . . . .	148 KNOTS
Cruise, 75% Power at 8500 Ft. . . . .	139 KNOTS
Cruise, 65% Power at 8500 Ft. . . . .	129 KNOTS

### CRUISE: Recommended Lean Mixture with fuel allowance for engine start, taxi, takeoff, climb and 45 minutes reserve at 45% power.

75% Power at 8500 Ft. . . . .	Range . . . . .	554 NM
51 Gallons Usable Fuel . . . . .	Time . . . . .	4 HRS: 5 MIN
75% Power at 8500 Ft. . . . .	Range . . . . .	373 NM
37 Gallons Usable Fuel . . . . .	Time . . . . .	3 HRS: 2 MIN

RATE OF CLIMB AT SEA LEVEL . . . . . 850 FPM

SERVICE CEILING . . . . . 13,800 FT

### TAKEOFF PERFORMANCE:

Ground Roll . . . . .	.865 FT
Total Distance Over 50-Ft Obstacle . . . . .	1550 FT

### LANDING PERFORMANCE:

Ground Roll . . . . .	.410 FT
Total Distance Over 50-Ft Obstacle . . . . .	1120 FT

### STALL SPEED (CAS):

Flaps Up, Power Off . . . . .	56 KNOTS
Flaps Down, Power Off . . . . .	53 KNOTS

MAXIMUM WEIGHT . . . . . 2400 LBS

STANDARD EMPTY WEIGHT: . . . . . 1398 LBS

BAGGAGE ALLOWANCE (Normal Category) . . . . . 120 LBS

WING LOADING: Pounds/Sq Ft . . . . . 17.1

POWER LOADING: Pounds/HP . . . . . 13.3

FUEL CAPACITY: Total . . . . . 52.6 GAL

OIL CAPACITY . . . . . 8 QTS

ENGINE: Avco Lycoming . . . . . 0-360-A4K

180 BHP at 2700 RPM

PROPELLER: Fixed, Diameter . . . . . 75 IN.

\*Performance specifications are based upon standard atmosphere, zero wind, and gross weight conditions.

## TABLE OF CONTENTS

	SECTION
GENERAL . . . . .	1
LIMITATIONS . . . . .	2
EMERGENCY PROCEDURES . . . . .	3
NORMAL PROCEDURES . . . . .	4
PERFORMANCE . . . . .	5
WEIGHT & BALANCE/ EQUIPMENT LIST . . . . .	6
AIRPLANE & SYSTEMS DESCRIPTION . . . . .	7
AIRPLANE HANDLING, SERVICE & MAINTENANCE . . . . .	8
SUPPLEMENTS (Optional Systems Description & Operating Procedures) . . . . .	9
SAFETY INFORMATION . . . . .	10

## WARRANTY

## GULFSTREAM AMERICAN MODEL AA-5B TIGER

GULFSTREAM AMERICAN CORPORATION (herein GULFSTREAM AMERICAN) warrants each new aircraft and part thereof manufactured by it, together with all new aircraft equipment and accessories bearing the name "GULFSTREAM AMERICAN," to be free from defects in material and workmanship under normal use and service, but extends no warranty of any kind, expressed or implied, to any items not manufactured by GULFSTREAM AMERICAN, or not so bearing its name, whether incorporated into or installed in the aircraft, except that the workmanship involved in installing such items is warranted to be without defect. The obligation of GULFSTREAM AMERICAN under this warranty is limited to replacement or repair, at the option of GULFSTREAM AMERICAN, of any such aircraft, or any part or accessory which shall within six (6) months (twelve (12) months on 1978 and subsequent models) of operation be found defective. Such aircraft, part or accessory is to be returned to a GULFSTREAM AMERICAN DEALER upon which examination by GULFSTREAM AMERICAN, shall disclose to its reasonable satisfaction to have been thus defective. This warranty shall not in any way apply to or cover any products which are in GULFSTREAM AMERICAN's opinion damaged as a result of being in any manner altered or repaired outside of the factory of GULFSTREAM AMERICAN or that shall have been subject to misuse or negligence.

GULFSTREAM AMERICAN makes no warranty whatsoever with respect to engines, radios, propellers, ignition apparatus, starting devices, generators, batteries, or other trade accessories, inasmuch as such products are generally warranted separately by their respective manufacturers.

"THESE WARRANTY PROVISIONS ARE EXPRESSLY IN LIEU OF ALL OTHER WARRANTIES, EXPRESSED, STATUTORY OR IMPLIED IN FACT OR BY LAW, INCLUDING ANY IMPLIED WARRANTY OF MERCHANTABILITY OR FITNESS FOR A PARTICULAR PURPOSE, AND OF ANY OTHER OBLIGATION OR LIABILITY ON THE PART OF GULFSTREAM AMERICAN, EXPRESSED OR IMPLIED, OF ANY NATURE WHATSOEVER. GULFSTREAM AMERICAN NEITHER ASSUMES NOR AUTHORIZES ANY OTHER PERSON OR BUSINESS ORGANIZATION TO ASSUME FOR IT ANY OTHER WARRANTY OR LIABILITY IN CONNECTION WITH THE SALE, USE OR OPERATION OF ITS PRODUCTS."

IMMEDIATELY ON COMMENCING FIRST USE OF AN AIRCRAFT, A WARRANTY VALIDATION CARD MUST BE FILLED OUT AND MAILED TO THE ATTENTION OF THE CUSTOMER SERVICE MANAGER, COMMERCIAL LIGHT AIRCRAFT, P.O. BOX 2206, SAVANNAH, GEORGIA, 31402. NO WARRANTY CLAIMS WILL BE HONORED IF THIS CARD IS NOT ON FILE AT THE FACTORY.



## SECTION 1 GENERAL

### TABLE OF CONTENTS

	Page
Three View . . . . .	1-2
Introduction . . . . .	1-3
Descriptive Data . . . . .	1-3
Engine . . . . .	1-3
Propeller . . . . .	1-3
Fuel . . . . .	1-4
Oil . . . . .	1-4
Maximum Certificated Weights . . . . .	1-8
Standard Airplane Weights . . . . .	1-9
Cabin and Entry Dimensions . . . . .	1-9
Baggage Space and Entry Dimensions . . . . .	1-9
Specific Loadings . . . . .	1-9
Symbols, Abbreviations and Terminology . . . . .	1-9
General Airspeed Terminology and Symbols . . . . .	1-9
Meteorological Terminology . . . . .	1-10
Engine Power Terminology . . . . .	1-10
Airplane Performance and Flight Planning Terminology . . . . .	1-11
Weight and Balance Terminology . . . . .	1-11

SECTION 1  
GENERAL

GULFSTREAM AMERICAN  
MODEL AA-5B TIGER

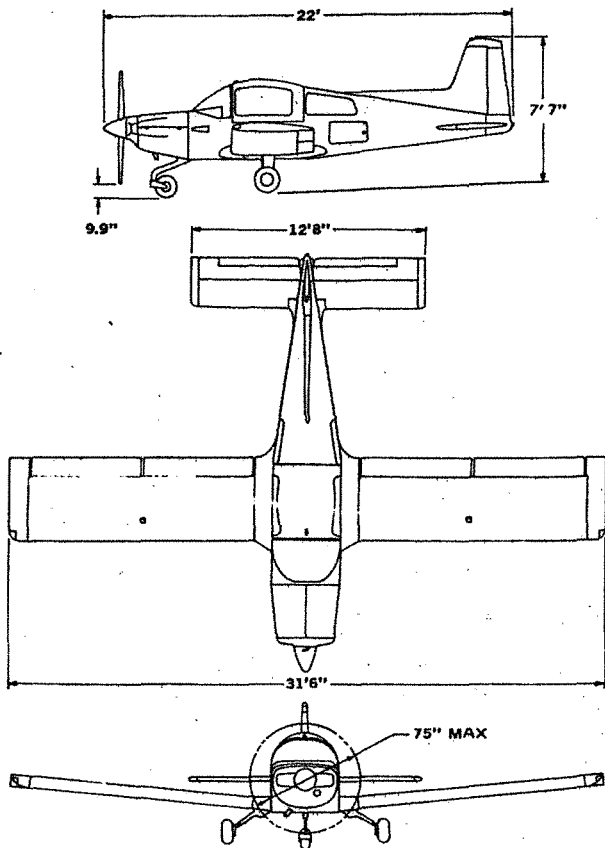

NOTES:

1. Wheel base length 5' 4"
2. Minimum turning radius 19' 11"
3. Pivot point — center of main gear tire.

Figure 1-1. Three View

Revised: July 15, 1978

## INTRODUCTION

The ten sections of this handbook contain the information needed by the pilot for safe and efficient operation of the Gulfstream Aerospace Model AA-5B airplanes. This handbook also includes the material required to be furnished to the pilot by FAR, Part 23, and supplemental data covering Gulfstream Aerospace designed optional equipment installed in the airplane.

Section 1 provides basic data and information of general interest to the pilot, to assist him in loading, sheltering, handling, and routine preflight checking of the airplane. Also included in this section are definitions and explanations of the symbols, abbreviations and terminology used in this handbook.

### NOTE

Unless otherwise noted, all performance and operational data in this book are based on sea level, standard day, and airplane gross weight conditions.

## DESCRIPTIVE DATA

### ENGINE

Number of Engines: 1

Manufacturer: Avco Lycoming

Model Number: O-360-A4K

Type: Normally-aspirated, direct-drive, air-cooled, horizontally-opposed, carburetor equipped, four-cylinder engine with 360 cubic inch displacement.

Horsepower Rating and Engine Speed: 180 HP at 2700 RPM

### PROPELLER

Manufacturer: McCauley

Model Number: 1A170/FFA 7563, 1A170/KFA 7563 or 1A170E/KFA 7563

Diameter: 75 inches

Type: Fixed pitch

SECTION 1  
GENERAL

GULFSTREAM AMERICAN  
MODEL AA-5B TIGER

FUEL

CAUTION

UNDER NO CIRCUMSTANCES  
SHOULD FUEL OF A LOWER OC-  
TANE RATING THAN THAT SPECI-  
FIED BELOW, OR AUTOMOTIVE  
FUEL (REGARDLESS OF OCTANE)  
BE USED.

Grade (and color): 100 Minimum Grade Aviation Fuel (green). 100 Low Lead Aviation Fuel (blue) is also approved. Refer to the latest revision of Lycoming Service Instruction No. 1070 for further information concerning fuels.

Capacity is at an ambient temperature of 70°F (21°C):

Total: 52.6 U.S. gallons (43.8 Imperial gallons) (199.0 Liters)  
Each Tank: 26.3 U.S. gallons (21.9 Imperial gallons) (99.5 Liters)  
Total Usable: 51 U.S. gallons (42.5 Imperial gallons) (193 Liters)

OIL

Grade (Specification):

Aviation Grade Straight Mineral Oil MIL-L-6082 (Figure 1-2) shall be used to replenish oil supply during the first 25 hours of operation and at the first 25-hour oil change. Continue to use this grade of oil for the first 50 hours of operation.

NOTE

The airplane is delivered from the factory with corrosion preventative airplane engine oil. This oil should be drained after the first 25 hours of engine operation.

MIL-L-22851 (Figure 1-2) Ashless Dispersant Oil: This specification oil shall be used after the first 50 hours of engine operation.

TRADE NAME	MANUFACTURER
<b>MIL-G-21164 GREASE (Note 1)</b>	
Aeroshell Grease 17 Braycote 664 PED 3350 Grease Royco 64 Grease TG-4727 Grease	Shell Oil Company Bray Oil Company Standard Oil Company Royal Lubricants Company Texaco Inc.
<b>MIL-G-6711 GRAPHITE (Note 1)</b>	
Graphite Graphite Graphite	Dixon Company Electrofilm Company Electro-Graph Company
<b>MIL-H-5606 HYDRAULIC FLUID (Note 1)</b>	
3125 HVD Oil Brayco Micronic 756C PED-3337, -3335 Royco 756A & B XSL 7828 YT-283	Humble Oil & Refining Company Bray Oil Company Standard Oil Company Royal Lubricants Company Shell Oil Company Union Carbide
<b>VV-P-236 PETROLATUM (Note 1)</b>	
Braycote 236 Parmo 70 Royco 1R	Bray Oil Company Humble Oil & Refining Company Royal Lubricants Company
<b>MIL-L-7870 OIL (Note 1)</b>	
Brayco 363 Cosmolube 263 Enco Instrument Oil Low Temperature Oil 1692 Royco 363	Bray Oil Company E. F. Houghton Company Humble Oil & Refining Company Texaco Inc. Royal Lubricants Company

Figure 1-2 Lubricants (Page 1 of 3)

SECTION 1  
GENERAL

GULFSTREAM AMERICAN  
MODEL AA-5B TIGER

TRADE NAME	MANUFACTURER
<b>MIL-G-25760 GREASE (Note 1)</b>	
Aeroshell Grease 16 Braycote 6605 Royco 60R Supermil ASU No. 06752 TG-4971 Grease	Shell Oil Company Bray Oil Company Royal Lubricants Company American Oil Company Texaco Inc.
<b>MIL-G-7711 GREASE (Note 1)</b>	
Aeroshell No. 6 Regal AFB 2	Shell Oil Company Texaco Inc.
<b>MIL-L-6082 STRAIGHT MINERAL OIL – ENGINE (Notes 1 and 2)</b>	
Aeroshell Oil 65 Aeroshell Oil 100 Chevron Aviation Oil 65 Grade 1100 Avrex 101/1065 Avrex 101/1100 Conoco Aero Oil 1065 Conoco Aero Oil 1100 Grade 1065 Grade 1100	Shell Oil Company Shell Oil Company Chevron Oil Company Chevron Oil Company Mobil Oil Company Mobil Oil Company Continental Oil Company Continental Oil Company Champion Oil & Refining Company Champion Oil & Refining Company
<b>MIL-L-22851 ASHLESS DISPERSANT OIL – ENGINE (Notes 1 and 2)</b>	
Aeroshell W120 Aeroshell W80 Chevron Aero Oil Grade 120 RT-451 RM-173E	Shell Oil Company Shell Oil Company Standard Oil Company Mobil Oil Company Mobil Oil Company

Figure 1-2 Lubricants (Page 2 of 3)

Issued: September 30, 1976

TRADE NAME	MANUFACTURER
<b>MIL-L-22851 ASHLESS DISPERSANT OIL – ENGINE (Notes 1 and 2) (Cont.)</b>	
RM-180E TX-6309 Premium AD 120 Premium AD 80 Oil E-120 Oil A-100 Oil E-80	Mobil Oil Company Texaco Inc. Texaco Inc. Texaco Inc. Exxon Company Exxon Company Exxon Company

Note 1: The vendor products listed in this chart have been selected as representative of the specification under which they appear. Other equivalent products conforming to the same specification may be used.

Note 2: Oils conforming to the latest revision of Lycoming Service Instruction No. 1014 may be used.

Figure 1-2 Lubricants (Page 3 of 3)

SECTION 1  
GENERAL

GULFSTREAM AMERICAN  
MODEL AA-5B TIGER

\*Recommended Viscosity:

<u>Average Ambient Air Temperature</u>	<u>Mineral Grade</u>	<u>Ashless Dispersant</u>
Above 60°F (16°C)	SAE 50	SAE 40 or SAE 50
30°F (-1°C) to 90°F (32°C)	SAE 40	SAE 40
0°F (-18°C) to 70°F (21°C)	SAE 30	SAE 40 or SAE 30
Below 10°F (-12°C)	SAE 20	SAE 30

\*Refer to latest revision of Lycoming Service Instruction No. 1014 for further information.

**Oil Capacity**

Sump: 8 U.S. Quarts (6.66 Imperial Quarts) (7.57 Liters)

Minimum Safe Quantity in Sump: 2 U.S. Quarts (1.67 Imperial Quarts) (1.89 Liters)

It is recommended that lubricating oil be changed at least every 50 hours of engine operation.

**MAXIMUM CERTIFICATED WEIGHTS**

Takeoff: Normal Category: 2400 pounds  
Utility Category: 2050 pounds

**CAUTION**

THE REAR SEATS SHALL NOT BE  
OCCUPIED DURING FLIGHT IN  
UTILITY CATEGORY OPERATIONS.

Landing: Normal Category: 2400 pounds  
Utility Category: 2050 pounds

Weight in Baggage Compartment, Normal Category: 120 pounds maximum allowable if c.g. is within Center of Gravity Envelope (Figure 6-5). Refer to Section 6 for cargo loading instructions.

Weight in Baggage Compartment, Utility Category: IN THIS CATEGORY THE BAGGAGE COMPARTMENT AND REAR SEATS SHALL NOT BE OCCUPIED.

Issued: September 30, 1976



## STANDARD AIRPLANE WEIGHTS

### NOTE

Actual weights for each airplane will vary, according to installed equipment. Refer to weight and balance data supplied with the particular airplane for specific data for that airplane.

**Standard Empty Weight:** 1398 lbs.

**Maximum Useful Load:** Normal Category: 1002

Utility Category: 652

## CABIN AND ENTRY DIMENSIONS

Detailed dimensions of the cabin interior and canopy opening are provided in Section 6.

## BAGGAGE SPACE AND ENTRY DIMENSIONS

Baggage area and access dimensions are provided in Section 6.

## SPECIFIC LOADINGS

**Wing Loading:** 17.1 pounds per square foot.

**Power Loading:** 13.3 pounds per B.H.P.

## SYMBOLS, ABBREVIATIONS AND TERMINOLOGY

### GENERAL AIRSPEED TERMINOLOGY AND SYMBOLS

- KCAS**      **Knots Calibrated Airspeed** is indicated airspeed corrected for position and instrument error and expressed in knots. Knots calibrated airspeed is equal to KTAS in standard atmosphere at sea level.
- KIAS**      **Knots Indicated Airspeed** is the speed shown on the outer scale of the airspeed indicator and expressed in knots.
- KTAS**      **Knots True Airspeed** is the airspeed expressed in knots relative to undisturbed air which is KCAS corrected for altitude and temperature.

SECTION 1  
GENERAL

GULFSTREAM AMERICAN  
MODEL AA-5B TIGER

- $V_A$             **Maneuvering Speed** is the maximum speed at which application of full available control will not overstress the airplane.
- $V_{FE}$            **Maximum Flap Extended Speed** is the highest speed permissible at which wing flaps can be extended.
- $V_{NO}$            **Maximum Structural Cruising Speed** is the speed that should not be exceeded except in smooth air, then only with caution.
- $V_{NE}$            **Never Exceed Speed** is the speed limit that may not be exceeded at any time.
- $V_S$             **Stalling Speed (Clean)** is the minimum steady flight speed at which the airplane is controllable.
- $V_{S_0}$           **Stalling Speed (Landing)** is the minimum steady flight speed at which the airplane is controllable in the landing configuration.
- $V_X$            **Best Angle-of-Climb Speed** is the speed which results in the greatest gain of altitude in a given horizontal distance.
- $V_Y$            **Best Rate-of-Climb Speed** is the speed which results in the greatest gain in altitude in a given time.

**METEOROLOGICAL TERMINOLOGY**

- OAT**            **Outside Air Temperature** is the free air static temperature. It is expressed in either degrees Celsius (Centigrade) or degrees Fahrenheit.
- Standard Temperature**      **Standard Temperature** is 15°C (59°F) at sea level pressure altitude and decreases by 2°C (4°F) for each 1000 feet of altitude.
- Pressure Altitude**          **Pressure Altitude** is the altitude read from an altimeter when the barometric subscale has been set to 29.92 inches of mercury (1013 mb).

**ENGINE POWER TERMINOLOGY**

- BHP**            **Brake Horsepower** is the power developed by the engine.
- RPM**           **Revolutions Per Minute** is engine speed (number of revolutions engine turns per minute).

Issued: September 30, 1976

#### AIRPLANE PERFORMANCE AND FLIGHT PLANNING TERMINOLOGY

<b>Demonstrated Crosswind Velocity</b>	<b>Demonstrated Crosswind Velocity</b> is the velocity of the crosswind component for which adequate control of the airplane during takeoff and landing was actually demonstrated during certification tests.
<b>Usable Fuel</b>	<b>Usable Fuel</b> is the fuel available for flight.
<b>Unusable Fuel</b>	<b>Unusable Fuel</b> is the quantity of fuel that cannot be used in flight.
<b>GPH</b>	<b>Gallons Per Hour</b> is the amount of fuel (in gallons) consumed per hour.
<b>g</b>	<b>g</b> is a unit of acceleration equivalent to that produced by the force of gravity.

#### WEIGHT AND BALANCE TERMINOLOGY

<b>Reference Datum</b>	<b>Reference Datum</b> is an imaginary vertical plane from which all horizontal distances are measured for balance purposes.
<b>Station</b>	<b>Station</b> is a location along the airplane longitudinal axis given in terms of the distance from the reference datum.
<b>Arm</b>	<b>Arm</b> is the horizontal distance from the reference datum to the center of gravity (c.g.) of an item.
<b>Moment</b>	<b>Moment</b> is the product of the weight of an item multiplied by its arm. (Moment divided by the constant 1000 is used in this Handbook to simplify balance calculations by reducing the number of digits.)
<b>Center of Gravity (c.g.)</b>	<b>Center of Gravity</b> is the point at which an airplane would balance if suspended. Its distance from the reference datum is found by dividing the total moment by the total weight of the airplane.
<b>c.g. Arm</b>	<b>Center of Gravity Arm</b> is the arm obtained by adding the airplane's individual moment and dividing the sum by the total weight.

**SECTION 1  
GENERAL**

**GULFSTREAM AMERICAN  
MODEL AA-5B TIGER**

<b>c.g. Limits</b>	<b>Center of Gravity Limits</b> are the extreme center of gravity locations within which the airplane can be operated at a given weight.
<b>Standard Empty Weight</b>	<b>Standard Empty Weight</b> is the weight of a standard airplane, including unusable fuel, full operating fluids and full engine oil.
<b>Basic Empty Weight</b>	<b>Basic Empty Weight</b> is the standard empty weight plus the weight of optional equipment.
<b>Useful Load</b>	<b>Useful Load</b> is the difference between maximum gross weight and the basic empty weight.
<b>Gross Weight</b>	<b>Gross Weight</b> is the maximum weight to which the airplane is certificated.
<b>Maximum Takeoff Weight</b>	<b>Maximum Takeoff Weight</b> is the maximum weight approved for the start of the takeoff run.
<b>Maximum Landing Weight</b>	<b>Maximum Landing Weight</b> is the maximum weight approved for the landing touchdown.
<b>Tare</b>	<b>Tare</b> is the weight of chocks, blocks, stands, etc., used when weighing an airplane, and is included in the scale readings. Tare is deducted from the scale reading to obtain the actual (net) airplane weight.

Issued: September 30, 1976

## SECTION 2 LIMITATIONS

### TABLE OF CONTENTS

	Page
Introduction .....	2-3
Airspeed Limitations .....	2-4
Airspeed Indicator Markings .....	2-4
Power Plant Limitations .....	2-5
Power Plant Instrument Markings .....	2-5
Weight Limits .....	2-6
Center of Gravity Limits .....	2-6
Maneuver Limits .....	2-7
Flight Load Factor Limits .....	2-8
Fuel Limitations .....	2-8
Placards .....	2-9

1900

10

1900

10

10

## INTRODUCTION

This section presents the operating limitations, instrument markings, and basic placarding necessary for the safe operation of the airplane, its engine, standard systems and standard equipment. Where the significance of an operating limitation, marking or placard is not obvious, an explanation is presented. Limitations associated with Gulfstream American designed optional equipment are contained in Section 9.

The Gulfstream American Model AA-5B is certificated under FAA Type Certificate No. A16EA.

The airplane is equipped for day VFR (with standard equipment) and may be equipped for night VFR and/or IFR operations. FAR Part 91 establishes the minimum required instruments and equipment for these operations. The reference to types of flight operations on the operating limitations placard reflects equipment installed at the time the Airworthiness Certificate was issued.

**THIS AIRPLANE IS NOT APPROVED FOR FLIGHT IN ICING CONDITIONS.**

**AIRSPPEED LIMITATIONS**

Airspeed limitations and their operational significance are shown in Figure 2-1.

	SPEED	KCAS (MPH CAS)	KIAS (MPH IAS)	REMARKS
V <sub>NE</sub>	Never Exceed Speed	174 (200)	172 (198)	Do not exceed this speed in any operation.
V <sub>NO</sub>	Maximum Structural Cruising Speed	143 (165)	142 (164)	Do not exceed this speed except in smooth air, and then only with caution.
V <sub>A</sub>	Maneuvering Speed	113 (130)	112 (129)	Do not make full or abrupt control movements above this speed.
V <sub>FE</sub>	Maximum Flap Extended Speed	104 (120)	103 (119)	Do not exceed this speed with flaps extended.
	Maximum Canopy Open Speed	113 (130)	112 (129)	Do not exceed this speed with canopy open.

Figure 2-1. Airspeed Limitations

**AIRSPPEED INDICATOR MARKINGS**

Airspeed indicator markings and their color code significance are shown in Figure 2-2.

MARKING	KCAS (MPH CAS) VALUE OR RANGE	SIGNIFICANCE
White Arc	53-104 (61-120)	Flap Operating Range. Lower limit is maximum weight V <sub>S0</sub> in landing configuration. Upper limit is maximum speed permissible with flaps extended.
Green Arc	56-143 (65-165)	Normal Operating Range. Lower limit is maximum weight V <sub>S</sub> with flaps retracted. Upper limit is maximum structural cruising speed.
Yellow Arc	143-174 (165-200)	Operations must be conducted with caution and only in smooth air.
Red Line	174 (200)	Maximum speed for any operations.

Figure 2-2. Airspeed Indicator Markings



### POWER PLANT LIMITATIONS

Engine Manufacturer: Avco Lycoming. Engine Model 0-360-A4K

Engine Operating Limits for Takeoff and Continuous Operations:

Maximum Power: 180 BHP  
Maximum Engine Speed: 2700 RPM  
Maximum Oil Temperature: 245°F (118°C)

Oil Pressure Minimum (idling): 25 PSI

Maximum: 100 PSI  
Normal Range: 60 to 90 PSI

Fuel Pressure, Minimum: 0.5 PSI, Maximum: 8 PSI

Propeller Manufacturer: McCauley

Propeller Model Number: 1A170/FFA 7563, 1A170/KFA 7563 or 1A170E/KFA 7563

Propeller Diameter, Maximum: 75 inches.

Propeller Operating Limits:

Avoid continuous operation between 1850 and 2250 RPM while descending.

### POWER PLANT INSTRUMENT MARKINGS

Power plant instrument markings and their color code significance are shown in Figure 2-3.

INSTRUMENT	RED LINE	GREEN ARC	YELLOW ARC	RED LINE
	MINIMUM LIMIT	NORMAL OPERATING	CAUTION RANGE	MAXIMUM LIMIT
Tachometer	—	2200 – 2700 RPM	1850 – 2250 RPM	2700 RPM
Oil Temperature	—	100°F – 245°F (38°C – 118°C)	— —	245°F (118°C)
Fuel Pressure	0.5 PSI	0.5 – 8 PSI	—	8 PSI
Oil Pressure	25 PSI*	60 – 90 PSI	—	100 PSI**

\*Idling

\*\*Start and warmup

Figure 2-3. Power Plant Instrument Markings

Revised: May 12, 1983

2-5

**SECTION 2  
LIMITATIONS**

**GULFSTREAM AEROSPACE  
MODEL AA-5B TIGER**

**WEIGHT LIMITS**

**NORMAL CATEGORY**

Maximum Takeoff Weight: 2400 lbs.  
Maximum Landing Weight: 2400 lbs.

Weight in Baggage Compartment, Normal Category: 120 pounds maximum allowable if C.G. is within center of gravity envelope (Figure 6-5). Refer to Section 6 for cargo loading instructions.

**UTILITY CATEGORY**

Maximum Takeoff Weight: 2050 lbs.  
Maximum Landing Weight: 2050 lbs.

Maximum Weight in Baggage Compartment: In the Utility Category, the baggage compartment and rear seat must not be occupied.

**CENTER OF GRAVITY LIMITS**

**NORMAL CATEGORY**

**Center of Gravity Range:**

Forward: 81.0 inches aft of datum at 1920 lbs. or less, with a straight line variation to 89.0 inches aft of datum at 2400 lbs.

Aft: 92.5 inches aft of reference datum at all weights up to 2400 lbs.

Reference Datum: 50.0 inches. It is located at the front face of lower portion of firewall.

**UTILITY CATEGORY**

**Center of Gravity Range:**

Forward: 81.0 inches aft of datum at 1920 lbs. or less, with a straight line variation to 83.17 inches aft of datum at 2050 lbs.

Aft: 85.32 inches aft reference of datum at all weights up to 2050 lbs.

Reference Datum: is 50.0 inches. It is located at the front face of lower portion of firewall.

## MANEUVER LIMITS

### NORMAL CATEGORY

This airplane is certificated in both the normal and utility category. The normal category is applicable to aircraft intended for non-aerobatic operations. These include any maneuvers incidental to normal flying, stalls (except whip stalls) and turns in which the angle of bank is not more than 60°.

Maximum Design Weight . . . . . 2400 lbs.  
Design Maneuvering Speed . . . . . 113 KCAS (130 MPH)

The AA-5B is approved for the following normal category maneuvers: Lazy eights, chandelles, and steep turns in which the angle of bank is not more than 60°.

### UTILITY CATEGORY

This airplane is not designed for aerobatic flight. However, in the acquisition of various certificates such as commercial pilot, instrument pilot and flight instructor, certain maneuvers are required by the FAA. All of these maneuvers, except spins, are permitted in this airplane when operated in the Utility Category.

Maximum Design Weight . . . . . 2050 lbs.  
Design Maneuvering Speed . . . . . 113 KCAS (130 MPH)

In the Utility Category, the baggage compartment and rear seat must not be occupied. No aerobatic maneuvers are approved except those listed below:

Maneuver	Recommended Entry Speed*
Chandelles . . . . .	113 KCAS (130 MPH)
Lazy Eights . . . . .	113 KCAS (130 MPH)
Steep Turns . . . . .	113 KCAS (130 MPH)
Stalls (Except Whip Stalls) . . . . .	Slow Deceleration
Spins Prohibited	

\*Abrupt use of the controls is prohibited above 113 KCAS (130 MPH).

**SECTION 2  
LIMITATIONS**

**GULFSTREAM AMERICAN  
MODEL AA-5B TIGER**

The important thing to remember in flight maneuvers is that the airplane is clean in aerodynamic design and will build up speed quickly with the nose down. Since proper speed control is essential for execution of any maneuver, care should always be exercised to avoid excessive speed and its resultant heavy airframe loads. In the execution of all maneuvers, avoid abrupt use of controls.

As noted, **SPINS ARE PROHIBITED**. In case of an inadvertent spin, recovery is effected by reducing throttle to idle, neutralizing the aileron, applying full rudder opposite to the spin rotation, and applying full down elevator simultaneously with rudder application. The controls should be applied briskly and held until rotation stops. As the rotation stops, neutralize the anti-spin rudder, then apply smooth elevator back pressure to bring the nose up to the level flight.

**FLIGHT LOAD FACTOR LIMITS**

**NORMAL CATEGORY**

**Flight Load Factors (Gross Weight – 2400 lbs.)**

Flaps Up . . . . . +3.8g, -1.52g  
Flaps Down . . . . . +3.5g

**UTILITY CATEGORY**

**Flight Load Factors (Gross Weight – 2050 lbs.)**

Flaps Up . . . . . +4.4g, -1.76g  
Flaps Down . . . . . +3.5g

**FUEL LIMITATIONS**

2 Tanks: 26.3 U.S. gallons each. (21.9 Imperial gallons) (99.5 Liters)  
Total Fuel: 52.6 U.S. gallons (43.8 Imperial gallons) (199.1 Liters)  
Usable Fuel (all flight conditions): 51 U.S. gallons (42.5 Imperial gallons)  
(193 Liters)

PLACARDS

The following information is displayed in the form of composite or individual placards:

- (1) In full view of the pilot:

THIS AIRPLANE MUST BE OPERATED AS A NORMAL OR UTILITY CATEGORY AIRPLANE IN COMPLIANCE WITH THE OPERATING LIMITATIONS STATED IN THE FORM OF PLACARDS, MARKINGS AND MANUALS.	
NORMAL CATEGORY—	
MAXIMUM DESIGN WEIGHT	.....2400 LBS
DESIGN MANEUVERING SPEED VA	.....113 KNOTS CAS
FLIGHT LOAD FACTORS:	
FLAPS UP	.....+3.8, -1.52
FLAPS DOWN	.....+3.5
NO ACROBATIC MANEUVERS, INCLUDING SPINS, APPROVED.	
UTILITY CATEGORY—	
MAXIMUM DESIGN WEIGHT	.....2050 LBS
DESIGN MANEUVERING SPEED VA	.....113 KNOTS CAS
FLIGHT LOAD FACTORS:	
FLAPS UP	.....+4.4, -1.76
FLAPS DOWN	.....+3.5
REAR SEAT MUST NOT BE OCCUPIED	
ACROBATIC MANEUVERING LIMITED TO THE FOLLOWING:	
MANEUVER	ENTRY SPEED-CAS
CHANDELLES	.....113 KNOTS
LAZY EIGHTS	.....113 KNOTS
STEEP TURNS	.....113 KNOTS
STALLS (EXCEPT WHIP STALLS)	.....SLOW DECELERATION
SPINS PROHIBITED	
MAXIMUM ALTITUDE LOSS IN STALL	.....350 FEET
DEMONSTRATED CROSSWIND VELOCITY	.....16 KNOTS
THIS AIRPLANE NOT APPROVED FOR FLIGHT IN ICING CONDITIONS.	
THIS AIRPLANE IS CERTIFIED FOR THE FOLLOWING OPERATIONS:	
IFR VFR DAY NIGHT WHEN PROPERLY EQUIPPED PER FAR 91	
REFER TO WEIGHT AND BALANCE DATA FOR LOADING INSTRUCTIONS.	
READ FUEL GAGES IN LEVEL FLIGHT ONLY.	
FOR NORMAL OPERATION - MAINTAIN FUEL BALANCE.	
5803007-96	AA-5B

- (2) On control gust lock:

<p><b>CONTROL LOCK</b></p> <p>REMOVE BEFORE STARTING ENGINE</p>
-----------------------------------------------------------------

**SECTION 2  
LIMITATIONS**

**GULFSTREAM AMERICAN  
MODEL AA-5B TIGER**

(3) On fuel selector valve:

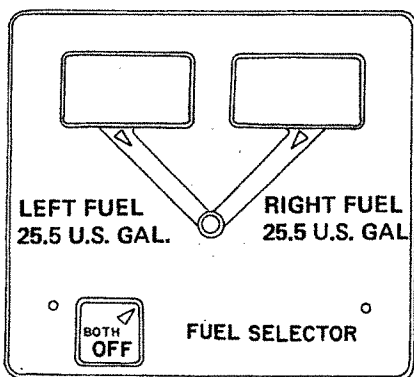

(4) Left side of instrument panel:

**FOR FLIGHT WITH REAR SEAT  
OCCUPANTS AND/OR BAGGAGE—  
CARGO, CHECK WEIGHT & BALANCE**

(5) Aft of fuel tank caps:

**FUEL  
MIN 100/130 OCT,  
26.3 U.S. GAL. TOTAL CAP.  
19.0 U.S. GAL. TO TAB**

(6) On instrument panel (if strobe lights are installed):

**TURN OFF STROBE IN CLOUD, FOG  
OR HAZE. TAXI WITH STROBE OFF**

(7) On instrument panel:

CAUTION: FLASHING BEACON IN CLOUDS  
MAY CAUSE VISUAL DISORIENTATION

(8) Adjacent to canopy latch:

FLAG INDICATES  
UNLATCHED CANOPY  

(9) In baggage compartment:

120 POUNDS MAXIMUM BAGGAGE  
FOR ADDITIONAL LOADING  
INSTRUCTIONS SEE WEIGHT AND  
BALANCE DATA  
NO HEAVY OBJECTS ON HAT SHELF

Under rear seat base:

**NO STEP**  
BEFORE FLIGHT  
SEAT BACK MUST BE  
TURNED DOWN TO COVER  
THIS AREA

On rear seat base:

NO PASSENGERS  
340 POUNDS MAXIMUM CARGO  
DISTRIBUTE EVENLY  
FOR ADDITIONAL LOADING  
INSTRUCTIONS SEE WEIGHT AND  
BALANCE DATA AND PILOTS  
OPERATING HANDBOOK

(10) Inside canopy rail, left side:

 113 KNOTS MAX WITH CANOPY OPEN TO HERE  
NO FLIGHT WITH CANOPY OPEN BEYOND THIS POINT

(11) Interior of canopy adjacent to lock.

  
PUSH  
TO  
UNLOCK

SECTION 2  
LIMITATIONS

GULFSTREAM AMERICAN  
MODEL AA-5B TIGER

(12) On wing outer ribs (if strobe lights are installed):

**WARNING**  
— HIGH —  
**VOLTAGE**  
WAIT 5 MINUTES AFTER  
SHUTTING OFF BEFORE STARTING  
ANY WORK ON THIS UNIT  
— CAUTION —  
THIS UNIT POLARITY SENSITIVE  
WHITE OR RED LEAD POSITIVE  
BLACK LEAD AND OR CASE NEGATIVE

(13) Adjacent to auxiliary power plug (if installed):

CAUTION: 12 VOLT  
D.C. ONLY, MASTER  
SW. MUST BE OFF

(14) On instrument panel:

AVOID CONTINUOUS OPERATION BETWEEN  
1850 & 2250 RPM WHILE DESCENDING

(15) On baggage door:

TO OPEN DOOR FROM INSIDE,  
SLIDE HANDLE FORWARD ➡

(16) On glove box door:

TIRE PRESSURE  
NOSE 25 LBS  
MAIN 35 LBS



## SECTION 3 EMERGENCY PROCEDURES

### TABLE OF CONTENTS

	Page
Introduction .....	3-3
Airspeeds For Safe Operations (IAS) .....	3-3

### OPERATIONAL CHECKLISTS

Engine Failures .....	3-3
Engine Failure During Takeoff Run .....	3-3
Engine Failure Immediately After Takeoff .....	3-3
Engine Failure During Flight .....	3-4
Forced Landings .....	3-4
Emergency Landing Without Engine Power .....	3-4
Precautionary Landing With Engine Power .....	3-4
Ditching .....	3-5
Fires .....	3-5
During Start On Ground .....	3-5
Engine Fire In Flight .....	3-6
Electrical Fire In Flight .....	3-6
Cabin Fire .....	3-6
Wing Fire .....	3-7
Icing .....	3-7
Inadvertent Icing Encounter .....	3-7
Landing With a Flat Main Tire .....	3-8
Landing With a Flat Nosewheel Tire .....	3-8
Electrical Power Supply System Malfunctions .....	3-8
Ammeter Shows Discharge .....	3-8

TABLE OF CONTENTS (Continued)

Page

AMPLIFIED PROCEDURES

Engine Failures .....	3-9
Forced Landings .....	3-10
Ground Fires .....	3-10
In-Flight Engine Fires .....	3-11
In-Flight Electrical Fires .....	3-11
Emergency Operation in Clouds .....	3-12
Vacuum System Failure .....	3-12
Executing a 180° Turn in Clouds .....	3-12
Emergency Descent Through Clouds .....	3-13
Recovery From a Spiral Dive .....	3-13
Flight In Icing Conditions .....	3-14
Static Source Blocked .....	3-15
Spins .....	3-16
Rough Engine Operation Or Loss Of Power .....	3-16
Carburetor Icing .....	3-16
Spark Plug Fouling .....	3-16
Magneto Malfunction .....	3-17
Low Oil Pressure/Engine Overheat .....	3-17
Electrical Power Supply System Malfunctions .....	3-17
Overvoltage Protection .....	3-18
Insufficient Output .....	3-18
Brake Failure .....	3-18
Windshield Obscuration .....	3-19

## INTRODUCTION

This section provides the pilot with checklists and amplified procedures that enable him to cope with emergencies that may be encountered in operating the airplane. If proper preflight inspections, operating procedures, and maintenance practices are used, emergencies due to airplane or engine malfunction should be rare. Likewise, careful flight planning and good pilot judgement can minimize enroute weather emergencies. However, should any emergency develop, the guidelines in this section should be considered and applied as necessary to correct the problem.

## AIRSPEEDS FOR SAFE OPERATIONS (IAS)

Engine Failure After Takeoff .....	.65 KIAS (75 MPH)
Maneuvering Speed .....	112 KIAS (129 MPH)
Maximum Glide .....	.72 KIAS (83 MPH)
Precautionary Landing With Engine Power .....	.65 KIAS (75 MPH)
Landing Without Engine Power .....	.65 KIAS (75 MPH)

## OPERATIONAL CHECKLISTS

### ENGINE FAILURES

#### Engine Failure During Takeoff Run

- (1) Throttle — IDLE.
- (2) Brakes — APPLY.
- (3) Mixture — IDLE CUT-OFF.
- (4) Ignition Switch — OFF.
- (5) Master — OFF.

#### Engine Failure Immediately After Takeoff

- (1) Airspeed — 65 to 75 KIAS (75 to 86 MPH)
- (2) Mixture — IDLE CUT-OFF.
- (3) Fuel Selector Valve — OFF.
- (4) Ignition Switch — OFF.
- (5) Master Switch — OFF.

**SECTION 3  
EMERGENCY PROCEDURES**

**GULFSTREAM AMERICAN  
MODEL AA-5B TIGER**

**Engine Failure During Flight**

- (1) Airspeed – 72 KIAS (83 MPH).
- (2) Carburetor Heat – ON.
- (3) Fuel Selector Valve – SWITCH TANKS.
- (4) Mixture – RICH.
- (5) Master Switch – ON
- (6) Auxiliary Fuel Pump – ON
- (7) Throttle – OPEN 1/4 inch
- (8) Ignition Switch – BOTH
- (9) Primer – IN and LOCKED.
- (10) Starter – PRESS if propeller is stopped.

**NOTE**

Gliding distance is approximately 1.7 nautical miles (2 statute miles) for each 1000 feet of altitude above terrain.

**FORCED LANDINGS**

**Emergency Landing Without Engine Power**

- (1) Airspeed – 72 KIAS (83 MPH)
- (2) Radio – TRANSMIT MAYDAY on 121.5 MHz giving location and intentions.
- (3) Mixture – IDLE CUT-OFF.
- (4) Fuel Selector Valve – OFF.
- (5) Ignition Switch – OFF
- (6) Wing Flaps – AS REQUIRED.
- (7) Master Switch – OFF.
- (8) Canopy – UNLATCH PRIOR TO TOUCHDOWN
- (9) Touchdown – SLIGHTLY NOSE HIGH.
- (10) Brakes – AS REQUIRED

**Precautionary Landing With Engine Power**

- (1) Airspeed – 65 KIAS (75 MPH)
- (2) Radio – Advise ATC of intentions.
- (3) Wing Flaps – AS REQUIRED
- (4) Select Fields – FLY OVER, noting terrain and obstructions, then retract flaps upon reaching a safe altitude and airspeed.
- (5) Radio and Electrical Switches – OFF
- (6) Wing Flaps – DN (on final approach).

- (7) Airspeed – 65 KIAS (75 MPH)
- (8) Master Switch – OFF.
- (9) Canopy – UNLATCH PRIOR TO TOUCHDOWN.
- (10) Touchdown – SLIGHTLY NOSE HIGH.
- (11) Ignition Switch – OFF
- (12) Brakes – AS REQUIRED.

#### Ditching

- (1) Radio – TRANSMIT MAYDAY ON 121.5 MHz, giving location and intentions (If electrical power is available).
- (2) Heavy Objects – SECURE
- (3) Flaps – DN
- (4) Approach – High Winds, Heavy Seas -- INTO THE WIND.  
Light Winds, Heavy Swells – PARALLEL TO SWELLS.
- (5) Power – ESTABLISH 350 FT/MIN DESCENT at 65 KIAS (75 MPH)
- (6) Canopy – FULLY OPEN
- (7) Touchdown – NOSE HIGH ATTITUDE AT MINIMUM DESCENT RATE AND AIRSPEED
- (8) Face – CUSHION at touchdown with folded coat or seat cushion
- (9) Airplane – EVACUATE through canopy
- (10) Life Vests and Raft – INFLATE

#### FIRES

##### During Start On Ground

- (1) Cranking – CONTINUE to get a start which would suck the flames and accumulated fuel through the carburetor and into the engine.

If engine starts:

- (2) Power – 1800 RPM for a few minutes.
- (3) Engine – SHUTDOWN and inspect for damage.
  - a. Fuel Selector – OFF
  - b. Master Switch – OFF.
  - c. Ignition Switch – OFF.

If engine fails to start:

- (4) Evacuate passengers.
- (5) Engine – SECURE.
  - a. Mixture – IDLE CUTOFF.

**SECTION 3  
EMERGENCY PROCEDURES**

**GULFSTREAM AMERICAN  
MODEL AA-5B TIGER**

- b. Master Switch — OFF.
  - c. Ignition Switch — OFF.
  - d. Fuel Selector Valve — OFF.
- (6) Fire — **EXTINGUISH** using fire extinguisher, seat cushion, wool blanket, or dirt.

**Engine Fire in Flight**

- (1) Mixture — **IDLE CUTOFF**
- (2) Fuel Selector Valve — **OFF**
- (3) Master Switch — **OFF**
- (4) Cabin Heat and Air — **OFF**
- (5) Airspeed — **115 KIAS (132 MPH)** If fire is not extinguished, increase glide speed to attempt to blow the fire out.
- (6) Forced Landing — **EXECUTE** (as described in Landing Without Engine Power).

**Electrical Fire in Flight**

If fire is in engine compartment:

- (1) Master Switch — **OFF**.
- (2) Vents/Cabin Air/Heat — **OFF/CLOSED**
- (3) Land airplane as soon as possible

If fire is in cockpit:

- (1) Master Switch — **OFF**
- (2) All Other Switches (except ignition switch) — **OFF**
- (3) Vents/Cabin Air/Heat — **CLOSED**
- (4) Fire Extinguisher — **ACTIVATE** (if available)

If fire appears to be out and electrical power is necessary to continue flight:

- (5) Master Switch — **ON**
- (6) Circuit Breakers — **CHECK** for faulty circuit, do not reset.
- (7) Radio/Electrical Switches — **ON** one at a time, with delay after each until short circuit is located.
- (8) Vents/Cabin Air/Heat — **OPEN** when fire is out.

**Cabin Fire**

- (1) Master Switch — **OFF**
- (2) Vents/Cabin Air/Heat — **CLOSED**

- (3) Fire Extinguisher — ACTIVATE (if available)

**WARNING**

AFTER DISCHARGING AN  
EXTINGUISHER WITHIN A CLOSED  
CABIN, VENTILATE THE CABIN.

- (4) Land the airplane as soon as possible to inspect for damage.

**Wing Fire**

- (1) Navigation Light Switch — OFF
- (2) Pitot Heat Switch (if installed) — OFF
- (3) Land as soon as possible.

**ICING**

**Inadvertent Icing Encounter**

- (1) Pitot Heat Switch — ON (if installed)
- (2) Carburetor Heat — ON as required

**NOTE**

Continuous engine operation with carburetor heat on is not recommended due to the decrease in engine efficiency. If severe icing conditions require extended use of carburetor heat the engine mixture should be leaned during use of carburetor heat.

- (3) Cabin Heat — ON
- (4) Defrosters — OPEN
- (5) Engine — Increase RPM, (do not exceed red line) and periodically change RPM to minimize ice buildup on propeller blades.
- (6) Turn back or change altitude to obtain outside air conditions that are less likely to cause icing.
- (7) If icing continues plan a landing at the nearest airport. Under extremely rapid icing conditions select a suitable emergency landing site.

**WARNING**

WITH AN ICE ACCUMULATION ON  
OR NEAR THE WING LEADING  
EDGES A HIGHER STALLING SPEED  
MAY BE EXPECTED. PLAN ALL  
MANEUVERS ACCORDINGLY.

- (8) Airspeed — If possible increase airspeed and fly at a higher than normal cruise speed until a landing is begun.
- (9) Approach for landing at a higher airspeed than normal depending on amount of ice accumulation.
- (10) Flaps — UP (Do not attempt to extend flaps for landing)
- (11) Land in a slightly nose high attitude.

**LANDING WITH A FLAT MAIN TIRE**

- (1) Wing Flaps — AS DESIRED
- (2) Elevator Control — NOSE HIGH
- (3) Aileron Control — BANK TOWARD GOOD TIRE.
- (4) Touchdown — GOOD TIRE FIRST, hold airplane off flat tire as long as possible.

**LANDING WITH A FLAT NOSEWHEEL TIRE**

- (1) Wing Flaps — AS DESIRED
- (2) Elevator Control — NOSE HIGH
- (3) Touchdown — hold nose gear off runway as long as possible.
- (4) Brakes — Use brakes cautiously. Allow airplane to roll to a stop if possible.

**ELECTRICAL POWER SUPPLY SYSTEM MALFUNCTIONS**

**Ammeter Shows Discharge**

- (1) Alternator Circuit Breaker — Check

**NOTE**

If circuit breaker trips, wait 15 seconds  
before resetting it.



- (2) Field Circuit Breaker — Check
- (3) If Field Circuit Breaker is tripped, land as soon as practical.
- (4) If Field Circuit Breaker is not tripped, and ammeter continues to show discharge, set alternator side of master switch to OFF and land as soon as practical.

### AMPLIFIED PROCEDURES

#### ENGINE FAILURES

If the engine fails during the takeoff run, prior to liftoff, the airplane should be stopped as soon as possible. In cases of partial failure (resulting in loss of power) the pilot may have the option of continuing the takeoff or aborting it. Obviously this is a decision that must be made by the pilot in light of existing conditions, however, an aborted takeoff (if possible) in most cases is the safest approach.

This checklist provides items that may assist the pilot in increasing the safety of the airplane during such situations.

If the engine fails (either completely or partially) it is essential that the nose of the airplane be lowered promptly so that a safe airspeed can be maintained. At low altitudes, in most cases, the airplane should be flown straight ahead for a landing, with only small directional changes to avoid obstructions or people on the ground. Seldom are there either the altitude or airspeed available for a 180° gliding turn back to the runway. These checklists are based upon the assumption that the pilot will have adequate time to secure the fuel and ignition systems prior to touchdown, however, the pilot must keep in mind that his primary duty is control of the airplane.

If the engine fails in flight (complete loss of power) the best glide speed, as shown in Figure 3-1 should be established as quickly as possible. Once the proper gliding speed has been established and a glide toward a suitable landing site entered, an effort should be made to determine the cause of the engine failure. If there is sufficient time an engine restart should be attempted per the checklist. Either lack of time for a restart or failure of the engine to start will necessitate a forced landing. Obviously a thorough knowledge of the airplane and the appropriate checklists may give the pilot that slight margin of time necessary to make a restart rather than a forced landing.

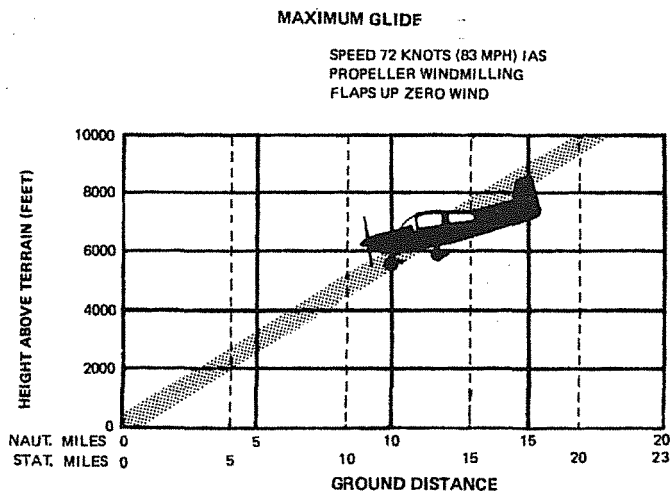

Figure 3.1 Maximum Glide

### FORCED LANDINGS

If the engine cannot be restarted and a forced landing is imminent, select a suitable landing zone and prepare for a landing as discussed in the **EMERGENCY LANDING WITHOUT ENGINE POWER** checklist.

If engine power is available and a landing is to be attempted at an area other than an airport, the landing area should be observed from a safe but low altitude. Inspect the terrain for obstructions and surface conditions prior to attempting a landing. Perform the landing as discussed in the **PRECAUTIONARY LANDING WITH ENGINE POWER** checklist.

If ditching is to be attempted heavy objects in the baggage area should be secured. Folded coats or cushions should be available for occupants to use for face protection at touchdown. If there is sufficient time, transmit a Mayday message on 121.5 MHz giving location and intentions. Perform the ditching as discussed in the **DITCHING** checklist.

### GROUND FIRES

Ground fires may be caused by over-priming the engine, therefore, proper procedures will help prevent fires when starting the engine.

Should a ground fire occur, the following procedures are suggested:

- (1) Keep the engine running to ingest the flames into carburetor. Increase engine RPM to 1800 RPM.
- (2) Dispatch ground personnel for fire equipment.
- (3) When assistance arrives, turn fuel selector valve OFF. Let engine stop due to fuel starvation. Set Master Switch and Ignition Switch to OFF.
- (4) If no assistance is available or the fire is beyond control, turn the fuel selector OFF, mixture OFF, Master Switch OFF, Ignition Switch OFF. ABANDON AIRCRAFT.

#### IN-FLIGHT ENGINE FIRES

In-flight engine fires in today's modern aircraft are extremely rare. It should be noted that the presence of smoke does not always mean that a flaming fire exists. For example, it may be engine oil on the exhaust system. If, in the pilot's judgement, an engine fire exists, the following procedures are suggested:

- (1) Mixture — IDLE CUTOFF
- (2) Fuel Selector Valve — OFF
- (3) Master Switch — OFF
- (4) Cabin Heat and Air — OFF
- (5) Establish a maximum safe rate of descent. Increasing speed may blow the fire out.
- (6) Slide slip maneuvers may be used, as necessary, to direct flames away from cabin area.
- (7) Select a suitable field for a forced landing.
- (8) Notify ATC if possible.
- (9) Complete the forced landing. Do not attempt to restart the engine.

#### IN-FLIGHT ELECTRICAL FIRES

Indication of in-flight electrical fires may be wisps of smoke or the smell of hot or burning insulation. Should an electrical fire develop, the following procedures are suggested:

If fire is in engine compartment:

- (1) Master Switch — OFF
- (2) Vent/Cabin Air/Heat — OFF/CLOSED
- (3) Land airplane as soon as possible

If fire is in cockpit:

- (1) Master Switch — OFF
- (2) All Other Switches (except ignition switch) — OFF
- (3) Vents/Cabin Air/Heat — CLOSED
- (4) Fire Extinguisher — ACTIVATE (if available)

If fire appears to be out and electrical power is necessary to continue flight:

- (5) Master Switch — ON
- (6) Circuit Breakers — CHECK for faulty circuit, do not reset.
- (7) Radio/Electrical Switches — ON one at a time, with delay after each until short circuit is located.
- (8) Vents/Cabin Air/Heat — OPEN when fire is out.

### EMERGENCY OPERATION IN CLOUDS

#### Vacuum System Failure

A vacuum system failure may disable the directional and attitude indicators, thus forcing the pilot to rely on the turn coordinator or turn and bank indicator if he inadvertently flies into clouds. The following procedures assume that only the electrically-powered turn coordinator or turn and bank indicator is operative, and the pilot is not instrument rated.

#### Executing a 180° Turn in Clouds

Upon inadvertently entering the clouds, an immediate plan should be made to turn back as follows:

- (1) Note the time of the minute hand and observe the position of the sweep second hand on the clock. Note compass heading.
- (2) When the sweep second hand indicates the nearest half-minute, initiate a standard rate left turn, holding the turn coordinator symbolic airplane wing opposite the lower left index mark for 60 seconds. Then roll back to level flight by leveling the miniature airplane.
- (3) Check accuracy of the turn by observing the compass heading which should be reciprocal of the original heading.
- (4) If necessary, adjust heading primarily with skidding motions rather than rolling motions so that the compass will read more accurately.
- (5) Maintain altitude and airspeed by cautious application of elevator control. Avoid overcontrolling by using a very small pitch control changes.

### Emergency Descent Through Clouds

If VFR flight conditions cannot be re-established by performing a 180° turn, a descent through the cloud deck to VFR conditions may be appropriate. If possible, obtain radio clearance for an emergency descent through clouds. To guard against a spiral dive, choose an easterly or westerly heading to minimize compass card swings due to changing bank angles. In addition, use a minimum control wheel movement and steer a straight course with rudder control by monitoring the turn coordinator. Occasionally check the compass heading and make minor corrections to hold an approximate course. Before descending into the clouds, set up a stabilized let-down condition as follows:

- (1) Apply full carburetor heat.
- (2) Reduce power to set up a 500 to 600 ft./min. rate of descent.
- (3) Adjust the elevator trim control wheel for a stabilized descent at 75 KIAS (86 MPH).
- (4) Use minimum control wheel motion and avoid abrupt movement.
- (5) Monitor turn coordinator and make corrections by rudder alone.
- (6) Check trend of compass card movement and make cautious corrections with rudder to stop turn.
- (7) Upon breaking out of clouds, resume normal cruising flight.

### Recovery From a Spiral Dive

If a spiral is encountered, proceed as follows:

- (1) Close throttle.
- (2) Stop the turn by using coordinated aileron and rudder control to align the symbolic airplane in the turn coordinator with the horizon reference line.
- (3) Cautiously apply elevator back pressure to slowly reduce the indicated airspeed to 75 KIAS (86 MPH).
- (4) Adjust the elevator trim control to maintain a 75 KIAS (86 MPH) glide.
- (5) Use minimum control wheel movement, using rudder control to hold a straight heading.
- (6) Apply carburetor heat.
- (7) Clear engine occasionally, but avoid using enough power to disturb the trimmed glide.
- (8) Upon breaking out of clouds, resume normal cruising flight.

### FLIGHT IN ICING CONDITIONS

Carburetor ice may be encountered at any time. Normally, the first indication of carburetor ice in the AA-5B is a slight drop in engine RPM, which may be accompanied by slight engine roughness. If carburetor icing is suspected, the following procedures are suggested:

- (1) Apply full carburetor heat. Engine roughness may then occur due to an over-rich mixture or water from the melting ice.

#### NOTE

Continuous engine operation with carburetor heat on is not recommended due to the resultant decrease in engine efficiency. If severe icing conditions require extended use of carburetor heat the engine mixture should be leaned during use of carburetor heat.

Flying in known icing conditions is prohibited by FAA regulations. However, should wing icing occur the following procedures are suggested:

- (1) Turn pitot heat ON
- (2) Turn cabin heat ON.
- (3) Open windshield defroster vent.
- (4) If IFR or under control of an in-flight ground facility, notify them of the condition and request assistance. A change of altitude, if possible, or reversing course to fly out of the icing conditions may be desirable.
- (5) Pilot technique is important in this situation:
  - A. Increase and decrease engine RPM (do not exceed red line) to keep propeller clear of ice.
  - B. Increase airspeed if possible. This technique reduces angle of attack exposing less surface area for ice accumulation.
  - C. Do not extend flaps. A clean configuration will expose less surface to ice and will prevent a change in air flow over the tail surfaces.
- (6) Monitor engine RPM for any indication of carburetor ice. (Refer to Carburetor Ice Procedures.)
- (7) Plan a landing at the first suitable airport. The following procedures are suggested:
  - A. If the windshield is obstructed, the canopy may be opened to improve visibility. A forward slip may be helpful.

- B. Remember that ice accumulation increases wing loading, decreases performance, decreases range and **INCREASES STALL SPEEDS**. When landing, plan a slightly higher than normal air speed during landing approach. Guard against increased stall speed created by the above mentioned conditions. Touch down in a slightly nose high attitude.

**REMEMBER: Intentional flying in icing conditions IS PROHIBITED!**

#### **STATIC SOURCE BLOCKED**

If erroneous readings are suspected on the instruments associated with the pitot-static system (airspeed indicator, altimeter and vertical speed indicator) pitot heat should be applied (for erroneous airspeed indications) in case the problem is due to ice or water accumulation in the pitot head. Failure of pitot heat to correct the problem may indicate blockage of the static sources. Obviously in a situation such as this, a landing should be planned at the nearest suitable airport. If it is necessary to continue the flight, and particularly if the flight is in marginal conditions, a static source must be supplied to the airspeed indicator and altimeter.

If an alternate air source is installed on your airplane, a static air source can be applied to these instruments by pulling out the ALT-STATIC AIR valve located on the left side of the instrument panel.

#### **NOTE**

Close the canopy when using alternate static air source. At airspeeds above 87 KIAS (100 MPH) subtract 6 KIAS (7 MPH) from indicated airspeed and 80 feet from indicated altitude.

If your airplane is not equipped with an alternate static air source, a static source can be supplied to the airspeed indicator and altimeter by breaking the glass on the face of the vertical speed indicator.

If this is done remember the following:

- (1) The vertical speed indicator will be inoperative.
- (2) Some error may be expected in airspeed and altitude indications. At airspeeds above 87 KIAS (100 MPH) subtract 6 KIAS (7 MPH) from indicated airspeed and 80 feet from indicated altitude.
- (3) The canopy must be kept closed, since opening it could introduce large errors in airspeed and altitude indications.

### SPINS

The AA-5B is not certificated for spins, in either the Normal or Utility category, therefore, **INTENTIONAL SPINS ARE PROHIBITED**. However, should inadvertent spin occur, the following recovery procedure is recommended:

- (1) Throttle — Idle
- (2) Ailerons — Neutral
- (3) Rudder — Hold opposite direction of rotation, full rudder.
- (4) Elevator — Full forward, simultaneously with rudder application.
- (5) Hold controls in these positions until rotation stops.
- (6) When rotation stops neutralize rudder and recover from dive.

### NOTE

If disorientation precludes a visual determination of the direction of rotation, the symbolic airplane in the turn coordinator or the needle of the turn and bank indicator may be referred to for this information.

### ROUGH ENGINE OPERATION OR LOSS OF POWER

#### Carburetor Icing

An unexplained drop in RPM and engine roughness may result from the formation of carburetor ice. To clear the ice, apply full throttle (do not exceed red line) and pull the carburetor heat knob full out until the engine runs smoothly. Then remove carburetor heat and readjust the throttle. If conditions require the continued use of carburetor heat in cruise flight use the minimum amount of heat necessary to prevent ice from forming and lean the mixture for smooth engine operation.

#### Spark Plug Fouling

A slight engine roughness in flight may be caused by one or more spark plugs becoming fouled by carbon or lead deposits. This may be verified by turning the ignition switch momentarily from BOTH to either L or R position. An obvious power loss in single ignition operation is evidence of spark plug or magneto trouble. Assuming that spark plugs are the most likely cause, lean the mixture to the recommended lean setting for cruising flight. If the problem does not clear up

Issued: September 30, 1976



in several minutes, determine if a richer mixture setting will produce smoother operation. If not, proceed to the nearest airport for repairs using the BOTH position of the ignition switch unless extreme roughness dictates the use of single ignition position.

#### **Magneto Malfunction**

A sudden engine roughness or misfiring is usually evidence of magneto problems. Switching from BOTH to either L or R ignition switch position will identify which magneto is malfunctioning. Select different power settings and use a richer mixture to determine if continued operation on BOTH magnetos is practicable. If not, switch to the good magneto and land at the nearest airport for repairs.

#### **Low Oil Pressure/Engine Overheat**

A low oil pressure reading may be caused by malfunction of the indicating system, oil pump failure, or loss of oil. Monitor the oil temperature gauge for a marked increase in temperature. If no temperature change is detected, the failure is most likely in the oil pressure indicating system.

Proceed to the nearest airport, land, check the oil level and determine the difficulty.

In flight, if the oil pressure indication is low and is accompanied by high oil temperatures, reduce power and proceed to the nearest airport or suitable landing area. If possible, notify the nearest ATC radio facility of your difficulty and land.

**REMEMBER: A THOROUGH AND COMPLETE PREFLIGHT WILL USUALLY PREVENT LOW OIL PRESSURE EMERGENCIES.**

#### **ELECTRICAL POWER SUPPLY SYSTEM MALFUNCTIONS**

The ammeter system on the AA-5B indicates current flow to or from the battery. During normal operation, with a fully charged battery, the ammeter will indicate near zero or slightly toward the charge side. This indication will be true even though all electrical systems are energized, unless the capacity of the alternator (60 amps) has been exceeded.

Failure of the alternator is easily detected since the ammeter will show discharge to the extent of the loads being applied.

Should a component of the electrical system fail (landing light, radio, turn and bank indicator, etc.), visually check the related circuit protector and replace or reset as required.

If the alternator field circuit breaker opens (pops out), wait 15 seconds then attempt to reset it by pushing the circuit breaker back into position.

If the field circuit breaker will not reset, turn off the alternator switch and land for electrical system inspection.

#### **Overvoltage Protection**

Overvoltage protection is provided by a diode attached to the field circuit breaker forward of the instrument panel. A sustained overvoltage condition will result in failure of the diode and subsequent opening of the alternator field circuit breaker. The breaker will not reset until the fault is corrected and the diode replaced. On 1978 Model Airplanes, the diode has been replaced by an overvoltage relay. A sustained overvoltage condition will cause the relay to energize and remove the field voltage of the alternator. The relay can be reset by placing the master switch to the OFF position. An alternator warning light is located on the instrument panel.

#### **Insufficient Output**

If the ammeter shows a discharge with the alternator switch ON, an alternator related failure has occurred, or the electrical loads have exceeded the rated output of the alternator due to a malfunction. Remove all unnecessary loads one at a time until the faulty load has been isolated. In any event, reduce all electrical loads as required to conserve battery energy.

#### **BRAKE FAILURE**

Brake failure is infrequent in any aircraft. However, if a brake failure is detected, proceed to the nearest airport with adequate runway length to accommodate an emergency brake-failure landing. It is not recommended, with a single brake failure, that either brake be utilized during landing and roll-out.

Plan the touchdown near the approach end of the runway. The aircraft nose should be aligned with the runway centerline. Use minimum safe airspeeds for existing conditions. Maintain directional control straight down the runway with use of rudder only. Allow the airplane to roll to a stop without the use of brakes. The engine may have to be stopped (with mixture control) to stop the ground roll. Request assistance from the appropriate ground control authority. It is recommended that towing to a parking area be accomplished manually with the hand tow bar or with a "tug".

Revised: December 15, 1977

**GULFSTREAM AMERICAN  
MODEL AA-5B TIGER**

**SECTION 3  
EMERGENCY PROCEDURES**

**WINDSHIELD OBSCURATION**

A windshield obscuration caused by ice or moisture condensation may be encountered. Turn cabin heat on and defroster vent full open to clear the windshield of moisture. If obscuration persists, open the canopy, and proceed to the nearest airport. A safe landing may be accomplished by using a forward slip to a landing while looking through the opening in the canopy.

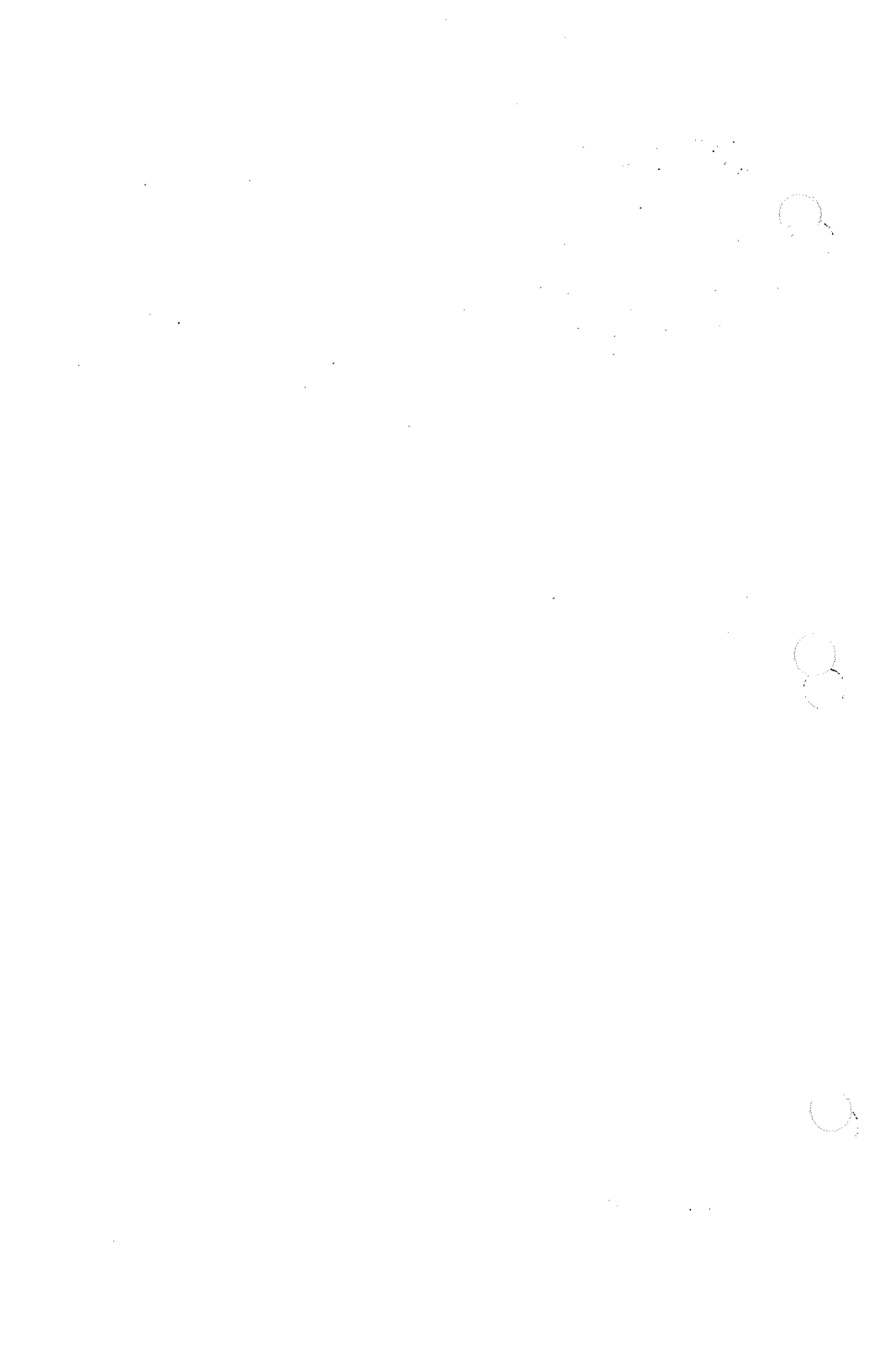

## SECTION 4 NORMAL PROCEDURES

### TABLE OF CONTENTS

	Page
Introduction . . . . .	4-3
Speeds for Safe Operation . . . . .	4-3

### CHECKLIST PROCEDURES

Preflight Inspection . . . . .	4-5
Cabin . . . . .	4-5
Left Wing, Trailing Edge . . . . .	4-5
Left Wing . . . . .	4-5
Left Wing, Leading Edge . . . . .	4-5
Left Cowl . . . . .	4-5
Nose . . . . .	4-6
Right Cowl . . . . .	4-6
Right Wing Leading Edge . . . . .	4-6
Right Wing . . . . .	4-7
Right Wing Trailing Edge . . . . .	4-7
Right Side of Fuselage . . . . .	4-7
Empennage . . . . .	4-7
Left Side of Fuselage . . . . .	4-7
Night Flight Preflight . . . . .	4-7
Electrical Systems Preflight . . . . .	4-7
Cabin . . . . .	4-7
Left Wing Tip . . . . .	4-8
Nose . . . . .	4-8
Right Wing . . . . .	4-8
Right Wing Tip . . . . .	4-8
Empennage . . . . .	4-8
Cabin . . . . .	4-8
Before Starting Engine . . . . .	4-8
Starting Engine . . . . .	4-8
Before Takeoff . . . . .	4-9
Takeoff . . . . .	4-10
Normal Takeoff . . . . .	4-10
Obstacle Clearance . . . . .	4-10
Climb . . . . .	4-10

SECTION 4  
NORMAL PROCEDURES

GULFSTREAM AMERICAN  
MODEL AA-5B TIGER

TABLE OF CONTENTS (Continued)

	Page
Cruise . . . . .	4-10
Descent . . . . .	4-11
Before Landing . . . . .	4-11
Balked Landing . . . . .	4-11
Landing . . . . .	4-11
Normal Landing . . . . .	4-11
Obstacle Clearance Landing . . . . .	4-12
After Landing . . . . .	4-12
Shut-Down/Securing Airplane . . . . .	4-13

AMPLIFIED PROCEDURES

Starting Engine . . . . .	4-13
Taxiing . . . . .	4-14
Warm-Up and Ground Check . . . . .	4-16
Takeoff . . . . .	4-16
Power Check . . . . .	4-16
Normal Takeoff . . . . .	4-16
Soft Field Takeoff . . . . .	4-17
Short Field Takeoff . . . . .	4-17
Crosswind Takeoff . . . . .	4-17
Climb . . . . .	4-18
Cruise . . . . .	4-18
Descent . . . . .	4-19
Stalls . . . . .	4-19
Landing . . . . .	4-20
Normal Landing . . . . .	4-20
Soft Field Landing . . . . .	4-21
Short Field Landing . . . . .	4-21
Crosswind Landing . . . . .	4-21
Balked Landings (Go-Arounds) . . . . .	4-21
Slips to Landings . . . . .	4-21
Ground Handling and Tiedown . . . . .	4-22
Cold Weather Operation . . . . .	4-22
Starting . . . . .	4-22
Starting With Preheat . . . . .	4-22
Starting Without Preheat . . . . .	4-23
Flight Operations . . . . .	4-24
Hot Weather Operation . . . . .	4-24
Noise Abatement . . . . .	4-24

**INTRODUCTION**

Section 4 provides checklist and amplified procedures for the conduct of normal operation of the AA-5B airplane. Normal procedures associated with Gulfstream American designed Optional Systems can be found in Section 9.

**SPEEDS FOR SAFE OPERATION**

Unless otherwise noted, the following speeds are based on a maximum weight of 2400 pounds and may be used for any lesser weight. However, to achieve the performance specified in Section 5 for takeoff distance, the speed appropriate to the particular weight must be used.

	KIAS	MPH
<b>Takeoff:</b>		
Normal Climb Out . . . . .	90	104
Maximum Performance Takeoff, Speed at 50 feet . . . . .	65	75
<b>Enroute Climb, Flaps Up:</b>		
Normal . . . . .	90	104
Best Rate of Climb, Sea Level . . . . .	90	104
Best Rate of Climb, 10,000 Feet . . . . .	79	90
Best Angle of Climb, Sea Level . . . . .	70	81
Best Angle of Climb, 10,000 Feet . . . . .	72	83
<b>Landing Approach:</b>		
Normal Approach, Flaps UP . . . . .	72	83
Normal Approach, Flaps DN . . . . .	69	78
Short Field Approach, Flaps DN . . . . .	63	73
<b>Balked Landing:</b>		
During Transition to Maximum Power, Full Flaps . . . . .	70	80
<b>Maximum Recommended Turbulent Air Penetration Speed:</b>		
2400 Lbs . . . . .	112	129
2050 Lbs . . . . .	112	129
<b>Maximum Demonstrated Crosswind Velocity:</b>		
Takeoff or Landing . . . . .		16 knots

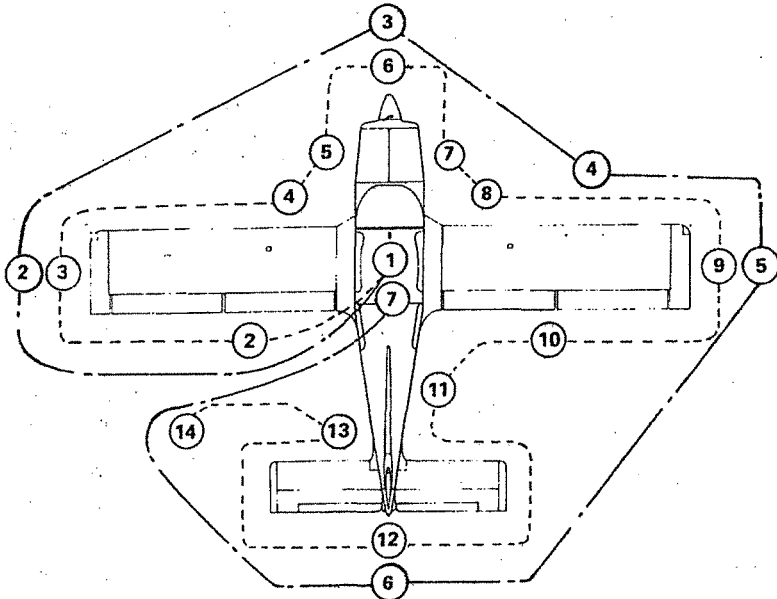

- PREFLIGHT INSPECTION
- ELECTRICAL SYSTEMS PREFLIGHT

NOTE

Visually check airplane for general condition during walk-around inspection. In cold weather, remove even small accumulations of frost, ice or snow from wing, tail and control surfaces.

Figure 4-1. Preflight Inspection



**CHECKLIST PROCEDURES**

**PREFLIGHT INSPECTION**

**1. Cabin**

- (1) Canopy — OPEN (turn handle counterclockwise to open.)
- (2) Control Wheel Lock — REMOVE
- (3) Ignition Switch — OFF.
- (4) Master Switch — OFF
- (5) Mixture — IDLE CUTOFF.

**2. Left Wing Trailing Edge**

- (1) Flap — Secure and undamaged.
- (2) Aileron — Freedom of movement

**3. Left Wing**

- (1) Wing Tip and Light — Undamaged
- (2) Aileron Counterweight Access — Unobstructed
- (3) Wing Inspection Plates — Secure
- (4) Tiedown — Removed
- (5) Pitot Tube — Unobstructed
- (6) Fuel Tank Vent — Unobstructed

**4. Left Wing Leading Edge**

- (1) Fuel Tank — Full, cap seal checked for damage, cap secure
- (2) Tank Drain — Fuel free of water and sediment, drain secure
- (3) Sump Drain — Fuel free of water and sediment, drain secure
- (4) Fuel — Proper color
- (5) Landing Gear Wheel Fairing and Tire — Undamaged, tire properly inflated
- (6) Chocks — Removed

**5. Left Cowl**

- (1) Windshield — Clean, undamaged
- (2) OAT Gauge — Secure, undamaged
- (3) Fuel Pump Overflow Drain — Unobstructed
- (4) Fresh Air Vents — Unobstructed
- (5) Air Cleaner Drain — Unobstructed
- (6) Oil Breather Vent — Unobstructed

SECTION 4  
NORMAL PROCEDURES

GULFSTREAM AMERICAN  
MODEL AA-5B TIGER

- (7) Cowling — Open, secured
- (8) Baffles — Secure, undamaged
- (9) Cowling — Closed, latches secured (flush with surface)

NOTE

If engine cowl is opened, ensure that its support tube is secured in the retainer clip prior to closing the cowl. Ensure that cowl latches are secure (flush with surface).

6. Nose

- (1) Propeller and Spinner — Secure, undamaged
- (2) Cowling — Secure, undamaged
- (3) Landing Light — Secured, undamaged
- (4) Nose Gear, and Fairing — Undamaged, tire properly inflated, mud scraper clear
- (5) Tow Bar — Removed and stowed
- (6) Chocks — Removed
- (7) Engine Cooling Openings — Unobstructed

7. Right Cowl

- (1) Cowl — Open
- (2) Engine Baffles — Unobstructed, undamaged
- (3) Carburetor Air Duct — Unobstructed
- (4) Engine Cooling Openings — Unobstructed
- (5) Engine Oil Level — 6 Quarts minimum, capacity 8 quarts
- (6) Engine Oil Dipstick — Secured (finger tight)
- (7) Vacuum Pump Vent — Unobstructed
- (8) Battery — Secure
- (9) Alternator Belt — Proper tension
- (10) Baffles — Secured, Undamaged
- (11) Cowl — Closed, latches secured (flush with surface)

8. Right Wing Leading Edge

- (1) Fuel Tank — Full, cap seal checked for damage, cap secured
- (2) Tank Drain — Fuel free of water and sediment, drain secured
- (3) Sump Drain — Fuel free of water and sediment, drain secure
- (4) Fuel — Proper color
- (5) Landing Gear, Wheel Fairing and Tire — Undamaged, tire properly inflated

- (6) Chocks – Removed
- 9. **Right Wing**
  - (1) Wing Tip and Light – Undamaged
  - (2) Aileron Counterweight Access – Unobstructed
  - (3) Wing Inspection Plates – Secured
  - (4) Tiedown – Removed
  - (5) Fuel Tank Vent – Unobstructed
- 10. **Right Wing Trailing Edge**
  - (1) Aileron – Freedom of movement
  - (2) Flap – Secure and undamaged
- 11. **Right Side of Fuselage**
  - (1) Static Source – Unobstructed
  - (2) Antennas – Secure, undamaged
  - (3) Fuselage – Undamaged
- 12. **Empennage**
  - (1) Elevators – Freedom of movement
  - (2) Rudder – Freedom of movement
  - (3) Trim Tabs – Secure, undamaged
  - (4) Tail Cone and Light – Secured, undamaged
  - (5) Tie Down – Removed
- 13. **Left Side of Fuselage**
  - (1) Static Source – Unobstructed
  - (2) Fuselage – Undamaged
  - (3) Baggage Door – Secure
- 14. **Night Flight Preflight**
  - (1) Fuses and Circuit Breakers – Check
  - (2) Spare Fuses – In Map Compartment
  - (3) Flashlight – Aboard
  - (4) Required Charts – Aboard

**ELECTRICAL SYSTEMS PREFLIGHT**

- 1. **Cabin**
  - (1) Master Switch – ON
  - (2) Instrument Lights – Check Rheostat, OFF
  - (3) Map Light and Dome Light – ON
  - (4) Navigation Lights – ON
  - (5) Flashing Beacon – ON
  - (6) Strobe Lights – ON
  - (7) Pitot Heat – ON
  - (8) Landing Light – ON

2. **Left Wing Tip**
  - (1) Navigation Light – Illuminated
  - (2) Strobe Light – Flashing

**WARNING**

**DO NOT TOUCH PITOT TUBE  
DIRECTLY, IT CAN BE HOT  
ENOUGH TO BURN SKIN.**

- (3) Pitot Tube – Check for heat
3. **Nose**
  - (1) Landing Light – Illuminated
4. **Right Wing**
  - (1) Stall Warning Vane – Lift, check that stall warning horn sounds
5. **Right Wing Tip**
  - (1) Navigation Light – Illuminated
  - (2) Strobe Light – Flashing
6. **Empennage**
  - (1) Navigation Light – Illuminated
  - (2) Flashing Beacon – Operating
7. **Cabin**
  - (1) Master Switch – OFF
  - (2) Navigation Lights – OFF
  - (3) Flashing Beacon – OFF
  - (4) Strobe Lights – OFF
  - (5) Pitot Heat – OFF
  - (6) Landing Light – OFF

**BEFORE STARTING ENGINE**

- (1) Preflight Inspection – Complete
- (2) Seats, Seat Belts and Shoulder Harness – Adjusted, locked
- (3) Radios, Autopilot, Electrical Equipment – OFF
- (4) Parking Brake – SET
- (5) Controls – Check for proper operation

**STARTING ENGINE**

- (1) Master/Alternator Switch – ON
- (2) Mixture – FULL RICH
- (3) Carburetor Heat – OFF

- (4) Fuel Selector Valve — Set to fullest tank
- (5) Prime — As required
- (6) Flaps — UP
- (7) Auxiliary Fuel Pump — ON (Check pressure 0.5 — 8 PSI)
- (8) Propeller — CLEAR
- (9) Ignition Switch — ON LEFT
- (10) Throttle — Open approximately 1/4-inch
- (11) Starter Button — Press, release when engine starts
- (12) Ignition Switch — ON BOTH
- (13) Oil Pressure — Check, if no pressure within 30 seconds, shut down engine
- (14) Engine — Warm up at 1000 to 1200 RPM
- (15) Auxiliary Fuel Pump — OFF

**NOTE**

Aviod prolonged idling while on the ground.

**BEFORE TAKEOFF**

- (1) Parking Brakes — SET
- (2) Throttle — Set for 1800 RPM
- (3) Engine Instruments — In green arc
- (4) Ammeter — Charging
- (5) Vacuum Gage — 4.6 to 5.4 in. Hg.
- (6) Magnetos — Check, 175 RPM maximum drop, not over 50 RPM difference between left and right magnetos
- (7) Carburetor Heat — ON, check for RPM drop, then set to OFF
- (8) Throttle — Set for 1000 RPM
- (9) Radios — ON, checked, Transponder — STANDBY
- (10) Engine — Idles smoothly
- (11) Engine is ready for takeoff when it will take throttle without hesitating or faltering and oil temperature is in green arc.
- (12) Trim Tab — SET
- (13) Flaps — Checked for operation, set UP
- (14) Mixture — FULL RICH (or as required by field elevation)
- (15) Throttle Friction Lock — ADJUSTED
- (16) Auxiliary Fuel Pump — ON, check for pressure change, then set to OFF
- (17) Flight Instruments — SET (clock, directional gyro, altimeter, radios)
- (18) Lights — ON, as required
- (19) Parking Brake — OFF
- (20) Turn Transponder ON after takeoff

SECTION 4  
NORMAL PROCEDURES

GULFSTREAM AMERICAN  
MODEL AA-5B TIGER

TAKEOFF

Normal Takeoff

- (1) Flaps — UP
- (2) Carburetor Heat — OFF
- (3) Auxiliary Fuel Pump — ON
- (4) Throttle — FULL OPEN
- (5) Elevator Control — Raise nosewheel at 50 KIAS (58 MPH) to 55 KIAS (62 MPH)
- (6) Climb Speed — 90 KIAS (104 MPH)

Obstacle Clearance Takeoff

- (1) Flaps — UP
- (2) Carburetor Heat — OFF
- (3) Auxiliary Fuel Pump — ON
- (4) Throttle — FULL OPEN
- (5) Elevator — Apply light back pressure at 50 KIAS (58 MPH), lift nosewheel at 55 KIAS (62 MPH)
- (6) Climb Speed — 65 KIAS (75 MPH)

CLIMB

- (1) Normal Climb Speed — 90 KIAS (104 MPH) at full throttle
- (2) Best Rate of Climb Speed — 90 KIAS (104 MPH) at sea level, full throttle
- (3) Best Angle of Climb Speed — 70 KIAS (81 MPH) at sea level, full throttle

CRUISE

- (1) Auxiliary Fuel Pump — OFF
- (2) Power — SET at 2200 to 2700 RPM
- (3) Trim Tab — SET as required
- (4) Mixture — SET as required. Full rich when operating at more than 75% power. If in doubt of percentage of power being used, use full rich mixture for operation below 5000 ft.

CAUTION

DO NOT OPEN CANOPY AT SPEEDS  
IN EXCESS OF 113 KIAS (130 MPH).

**DESCENT**

- (1) Power — As required for descent

**NOTE**

While descending avoid continuous operation at engine speeds between 1850 and 2250 RPM.

- (2) Mixture — As required by altitude
- (3) Carburetor Heat — As required by engine power setting and weather conditions
- (4) Trim Tab — SET as required

**BEFORE LANDING**

- (1) Seats, Seat Belts and Shoulder Harness — Adjust and lock
- (2) Fuel Selector — On fullest tank
- (3) Mixture — FULL RICH
- (4) Auxiliary Fuel Pump — ON
- (5) Carburetor Heat — ON if required
- (6) Parking Brake — OFF
- (7) Flaps — Set as required, below 103 KIAS (119 MPH)
- (8) Airspeed — 65 KIAS (75 MPH) to 70 KIAS (80 MPH)
- (9) Landing Light — ON as required

**BALKED LANDING**

- (1) Power — Full throttle
- (2) Carburetor Heat — OFF
- (3) Airspeed — 70 KIAS (80 MPH)
- (4) Establish Climb Attitude
- (5) Flaps — Retract slowly, maintain safe airspeed

**LANDING**

**Normal Landing**

- (1) Touch down on main gear.

**SECTION 4  
NORMAL PROCEDURES**

**GULFSTREAM AMERICAN  
MODEL AA-5B TIGER**

**CAUTION**

IF THE NOSE GEAR IS ALLOWED TO CONTACT THE RUNWAY PRIOR TO MAIN GEAR TOUCHDOWN A PORPOISE MANEUVER MAY OCCUR. SHOULD THE AIRPLANE BEGIN PORPOISING RECOVER AS FOLLOWS:

- A. APPLY FULL POWER
- B. MAINTAIN STEADY ELEVATOR BACK PRESSURE FOR A NORMAL CLIMB.
- C. ESTABLISH A NORMAL CLIMB AT 90 KIAS (104 MPH)
- D. SLOWLY RETRACT FLAPS
- E. EXECUTE A NORMAL GO-AROUND.

- (2) Lower nosewheel slowly as speed decreases.
- (3) Use rudder to maintain directional control down to approximately 17 KIAS (20 MPH)
- (4) Brakes — Use as required for stopping and directional control.

**Obstacle Clearance Landing**

- (1) Flaps — Fully extended below 103 KIAS (119 MPH)
- (2) Airspeed — 63 KIAS (73 MPH)
- (3) Touch down on main gear
- (4) Elevator — Full up control
- (5) Flaps — UP
- (6) Brakes — As required for directional control and stopping.

**AFTER LANDING**

- (1) Flaps — UP
- (2) Auxiliary Fuel Pump — OFF
- (3) Landing Light — OFF (if used)
- (4) Carburetor Heat — OFF
- (5) Strobe Light — OFF (if used)



### SHUT-DOWN/SECURING AIRPLANE

- (1) Electrical Equipment, Radios, Lights — OFF
- (2) Mixture — IDLE CUTOFF
- (3) Ignition — OFF (after propeller has stopped)
- (4) Master Switch — OFF
- (5) Control Lock — Installed
- (6) Parking Brake — SET
- (7) Chocks/Tiedowns — Installed
- (8) Parking Brake — OFF

### AMPLIFIED PROCEDURES

#### STARTING ENGINE

Before priming, apply brakes. It is good practice to have all radios and lights off, both to limit battery drain during the start and to protect avionics from voltage surges.

#### NOTE

Normally, one to three strokes of the priming pump is sufficient for quick starting. In temperatures below 40°F (4°C), however, four to six strokes may be necessary. During extremely cold days, starting will be aided by pulling the propeller through four or five revolutions by hand. SWITCHES MUST BE OFF WHEN PULLING THE PROPELLER. Preheating the engine or oil before starting in temperatures of 10°F and below will speed the start and conserve the battery charge.

**SECTION 4  
NORMAL PROCEDURES**

**GULFSTREAM AMERICAN  
MODEL AA-5B TIGER**

With brakes applied, place the mixture in the full rich position; open throttle 1/4 inch; turn master switch and alternator switch ON; clear propeller area; set ignition switch to left; and engage the starter. If the engine fails to start on the first attempt, a second attempt should be made without priming. If the day is hot and the second attempt fails, it is possible the engine is over-primed. Pull the mixture control to full lean, throttle full open, and turn the engine with the starter. When the engine starts, push the mixture control to full rich and reduce throttle. If the day is cold, it is more likely the engine is under-primed. In this event, a few extra strokes of the primer should provide a prompt start. As soon as engine starts set ignition to both.

Check the oil pressure when the engine starts. If no oil pressure is indicated within 30 seconds (60 seconds on a very cold day), stop the engine and determine the source of trouble. Oil pressure should indicate approximately 25 PSI with the engine at idle. Release parking brake by pushing parking brake knob and pressing brakes.

**NOTE**

Parking brake can be operated only from the left front seat.

**TAXIING**

All taxiing should be done at slow speed, and the controls should be positioned such that the affects of gusty wind are minimized. (See Taxiing Diagram, Figure 4-2.) Since the rudder controls on the AA-5B are not directly coupled to the nosewheel directional control during taxiing is maintained by use of differential braking.

Taxiing over loose gravel or cinders should be done at low engine speed to minimize damage to the propeller tips, landing gear and empennage due to abrasion or stone damage.

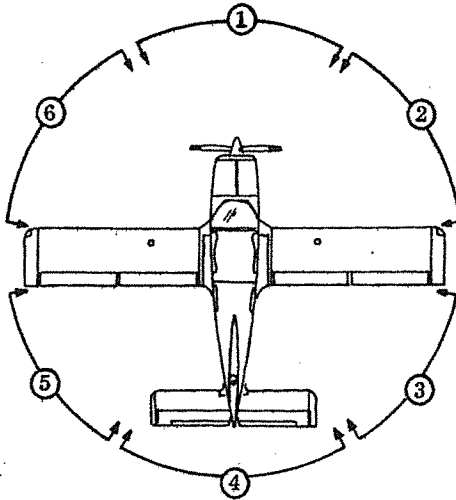

NUMBER	WIND DIRECTION	CONTROL POSITION
(1)	FWD	Wheel Neutral -- Back
(2)	FWD RH Quarter	Wheel Right -- Back
(3)	Aft RH Quarter	Wheel Left -- Forward
(4)	AFT	Wheel Neutral -- Forward
(5)	Aft LH Quarter	Wheel Right -- Forward
(6)	FWD LH Quarter	Wheel Left -- Back

Figure 4-2. Taxiing Diagram

### WARM-UP AND GROUND CHECK

Engine warm-up should be at 1000 to 1200 RPM. The magneto check is run at 1800 RPM using the BOTH-RIGHT-BOTH-LEFT-BOTH sequence. Maximum RPM drop per magneto should not exceed 175 RPM, or 50 RPM differential between magnetos. The carburetor heat should be checked for operation at this time, then returned to the full OFF position. The engine is ready for takeoff when it will take full throttle without hesitation or faltering.

### TAKEOFF

#### Power Check

It is important to check full-throttle engine operation early in the takeoff run. Any sign of rough engine operation or sluggish engine acceleration is good cause for discontinuing the takeoff.

Smooth and uniform throttle application should be used to ensure best engine acceleration and to give long engine life. This technique is important under hot weather conditions which may cause a rich mixture that could hinder engine response if the throttle is applied too rapidly.

Full-throttle runups over loose gravel are especially harmful to propeller tips. When takeoffs must be made over a gravel surface, it is very important that the throttle be advanced slowly. This allows the airplane to start rolling before high RPM is developed, and the gravel will be blown back of the propeller rather than pulled into it.

Prior to takeoff from fields above 5000 feet elevation, the mixture should be leaned to give maximum power.

After full throttle is applied, adjust the throttle friction lock clockwise to prevent the throttle from creeping back from a maximum power position. Similar friction lock adjustment should be made as required in other flight conditions to maintain a fixed throttle setting.

#### Normal Takeoff

Before beginning the takeoff roll, align the airplane with the runway. Aligning the nose wheel with the takeoff direction will allow minimum brake usage during the initial ground roll. When full power is applied for takeoff, directional control is maintained with light toe pressure on the brakes. At speeds above 13 KIAS (15 MPH) to 17 KIAS (20 MPH), the rudder becomes fully effective and brake steering is NOT necessary. Continued use of brake steering will only prolong the takeoff roll.

Accelerate to 50 KIAS (58 MPH) before applying a light back pressure on the control wheel to lift off the nose wheel. Raising the nose wheel too soon or to an excessive angle may increase takeoff ground distance. When airborne, accelerate to the desired climb speed.

#### **Soft Field Takeoff**

After alignment in the takeoff direction and with the elevator held in the full up position, apply takeoff power smoothly. As the airplane accelerates and the elevator becomes effective, the nose load will lighten reducing nose wheel drag. As the nose raises, the elevator should be eased forward so the nose wheel is held just clear of the ground. After lift off, accelerate to the best angle of climb speed 70 KIAS (81 MPH) or best rate of climb speed 90 KIAS (104 MPH) depending on obstacles.

#### **NOTE**

Avoid prolonged engine run-up in loose gravel, since the propeller will tend to pick up stones and debris causing propeller blade, landing gear and empennage damage.

#### **Short Field Takeoff**

After alignment in the takeoff direction, hold the brakes to prevent movement and apply full throttle. When full power is reached, release brakes and begin the takeoff roll with the elevator neutral. Use light smooth brake pressures to maintain low speed directional control. At 55 KIAS (63 MPH) apply elevator back pressure for rotation, then climb at 65 KIAS (75 MPH) below 50 ft. If terrain or further obstacles are to be cleared after takeoff and above the 50 foot obstacle, accelerate to the best angle of climb speed 70 KIAS (81 MPH) at sea level. When obstacles are cleared, accelerate to the desired climb speed.

#### **Crosswind Takeoff**

The airplane is accelerated to a speed slightly higher than normal, then flown off abruptly to prevent possible settling back to the runway while drifting. When clear of the ground, make a coordinated turn into the wind to correct for drift.

### CLIMB

A normal climb speed of 90 KIAS (104 MPH) is recommended once all ground obstacles have been cleared. This speed offers good visibility, excellent over-the-ground speed and rate of climb. The best rate of climb speed varies from 90 KIAS (104 MPH) at sea level to 79 KIAS (90 MPH) at 10,000 ft. The best angle of climb speed varies from 70 KIAS (81 MPH) at sea level to 72 KIAS (83 MPH) at 10,000 ft. Refer to Section 5 performance charts for additional information.

### NOTE

The mixture should be full rich during takeoff and climb at altitudes below 5000 ft. MSL. However, during takeoff or climb from high-altitude airports, the engine should be leaned to achieve best power (maximum RPM).

### CRUISE

The maximum recommended cruise power setting is 100% of the rated horsepower. True airspeeds, which are determined by the particular altitude and power setting chosen, can be obtained from the tables in Section 5.

### NOTE

On new airplanes power should be maintained at 75% power or more until a total of 50 hours has accumulated. This is to ensure proper seating of the rings and is applicable to new engines, and engines in service following cylinder replacement or top overhaul of one or more cylinders.

After the initial break-in period, fuel consumption can be reduced significantly, especially at high altitudes, by leaning the mixture in cruising flight. For optimum fuel consumption in cruise at 75% power or less, lean the mixture as follows:

- (1) Slowly move the mixture control from full rich position toward lean position.

- (2) Continue leaning until engine roughness is noted.
- (3) Enrich mixture slightly until engine runs smoothly.

The Cruise Performance fuel consumption given in Section 5 is based upon this leaning technique.

**NOTE**

If engine runs rough during cruise with carburetor heat on, it may be due to an over-rich condition. To correct for engine roughness in such a situation, lean to smooth engine operation.

**DESCENT**

Power on descents of up to 143 KIAS (165 MPH) can be utilized to reduce enroute flight time. Higher airspeeds are permissible in smooth air conditions. Placarded airspeed limitations must be observed.

**NOTE**

Avoid continuous operation between 1850 and 2250 RPM while descending.

**STALLS**

The AA-5B's stall characteristics are conventional in all configurations. Elevator buffeting occurs approximately 2 KIAS (3 MPH) above the stall and becomes more pronounced as the stall occurs. An audible stall warning horn begins to blow steadily 5 KIAS to 10 KIAS above the actual stall speed.

**NOTE**

Rudder is the primary control for yaw and roll through the stall. In addition, the aileron is effective for roll control. Both controls should be used as necessary to control roll and yaw through the stall. For specific stall speeds at maximum weight with flaps up and down, refer to the Stall Speed Table in Section 5.

## LANDING

### Normal Landing

Trim the airplane to an approach speed between 65 KIAS (75 MPH) and 70 KIAS (80 MPH) depending on weight and wind conditions. Normal approach speed is 65 KIAS (75 MPH). Maximum flap extension speed is 103 KIAS (119 MPH). Any flap setting may be used for landings.

As a general rule, it is good practice to contact the ground at a minimum safe speed consistent with existing conditions. After touchdown, hold the nose wheel off as long as possible on roll-out. Lower the nose gently and apply brakes as needed. Retract the flaps after touchdown to minimize the possibility of skidding when braking. In gusty or crosswind conditions, many pilots prefer to increase their airspeed slightly above the normal approach speed; this decision, however, can only be made by the pilot in light of his own experience and training.

### NOTE

A power-off nose-high touchdown attitude is the best assurance of a porpoise-free landing, and excessive touchdown speed is not required with direct crosswinds up to 16 knots.

A pilot-induced porpoise maneuver may be encountered during landing by contacting the nose wheel first. The porpoise could be accentuated by a wavy or rolling runway surface. Should a porpoise occur, use the following technique to recover:

- (1) Apply full power.
- (2) Maintain steady elevator-back pressure for a normal climb.
- (3) Normal climb — 90 KIAS (104 MPH).
- (4) Carburetor heat — OFF
- (5) Retract flaps.
- (6) Execute normal go-around



### **Soft Field Landing**

For soft fields, the airplane should be trimmed to an approach speed of 63 KIAS (73 MPH) with flaps fully extended. Use power as necessary to control glide path consistent with existing conditions. Touchdown in a rough or soft field should be in a nose-high pitch attitude at the slowest safe airspeed. The nose wheel should be held off the surface as long as possible, and braking should be the minimum required for directional control and safety. (Maximum braking on soft surfaces may lead to excessive gear loads.)

### **Short Field Landing**

When making a landing where obstacle clearance or ground roll is a factor, the AA-5B should be trimmed to an approach speed of 63 KIAS (73 MPH) with flaps fully extended. Touchdown should be made on the main gear at the slowest safe airspeed. Best braking can be obtained by applying light pressure immediately after touchdown and continuously increasing brake pressure just enough so the wheels do not skid.

### **Crosswind Landing**

When landing in a strong crosswind, use the minimum flap setting required for the field length. Although the crab or combination method of drift correction may be used, the crab method gives the best control. After touchdown, hold a straight course with the rudder and occasional braking.

### **BALKED LANDINGS (Go-Arounds)**

Should a landing be balked, apply full power immediately; carburetor heat OFF; establish a positive rate of climb at 70 KIAS (80 MPH); retract the flaps and trim for normal climb.

### **SLIPS TO LANDINGS**

Slips are very effective in the AA-5B. Rapid descents with high sink rates can be obtained through a properly executed slip. It is recommended, however, that slips be practiced at a safe altitude until the pilot is familiar with the AA-5B. The recommended slip speeds are 65 KIAS (75 MPH) to 75 KIAS (86 MPH) depending on load, pilot proficiency, and local conditions. Pilots should make themselves familiar with the airplane at a variety of slip speeds.

### GROUND HANDLING AND TIEDOWN

The AA-5B is easily handled on the ground by hand with the aid of a tow bar attached to the nose wheel fork. Tiedown rings are provided under each wing tip and under the tail. Proper tiedown is the best insurance against damage to the airplane by gusty or strong winds. Installation of the control wheel lock helps avoid damage to the movable surfaces under such conditions.

#### NOTE

Install wheel chocks and release the parking brake if the airplane is to be left unattended. Changes in ambient temperature can cause the brakes to release or to exert excessive pressure.

### COLD WEATHER OPERATION

#### Starting

Prior to starting on a cold morning, it is advisable to pull the propeller through several times by hand to "break loose" or "limber" the oil, thus conserving battery energy. Use auxiliary power if airplane is equipped for it.

#### WARNING

WHEN PULLING THE PROPELLER THROUGH BY HAND, TREAT IT AS IF THE IGNITION SWITCH IS TURNED ON. A LOOSE OR BROKEN GROUND WIRE ON EITHER MAGNETO COULD CAUSE THE ENGINE TO START.

#### Starting With Preheat:

- (1) With ignition switch turned off and throttle closed, prime the engine four to eight strokes as the propeller is being turned over by hand.

#### NOTE

Use heavy strokes of the primer for best atomization of fuel. After priming, push primer all the way in and turn to the locked position to avoid the possibility of the engine drawing fuel through the primer.

- (2) Mixture — FULL RICH.
- (3) Propeller Area — CLEAR.
- (4) Master Switch — ON.
- (5) Throttle — OPEN 1/2 INCH.
- (6) Ignition Switch — ON LEFT.
- (7) Starter Button — Press, release when engine starts.
- (8) Ignition Switch — ON BOTH.
- (9) Oil Pressure — Check

**Starting Without Preheat:**

- (1) Prime the engine six to ten strokes while the propeller is being turned by hand with the throttle closed. Leave the primer charged and ready for a stroke.
- (2) Mixture — FULL RICH.
- (3) Propeller Area — CLEAR.
- (4) Master Switch — ON.
- (5) Ignition Switch — ON LEFT.
- (6) Pump Throttle rapidly to full open twice. Return to 1/2 inch open position.
- (7) Starter Button — Press, release when engine starts.
- (8) Ignition Switch — ON BOTH.
- (9) Continue to prime the engine until it is running smoothly, or alternately pump the throttle rapidly over the first 1/4 of total travel.
- (10) Oil Pressure — CHECK.
- (11) Apply full carburetor heat after the engine has started. Leave on until the engine is running smoothly.
- (12) Primer — LOCKED.

**NOTE**

If the engine does not start or if engine firing diminishes in strength, it is probable that the spark plugs have been frosted over. Preheat must be used before attempting another start.

**CAUTION**

PUMPING THE THROTTLE MAY CAUSE RAW FUEL TO ACCUMULATE IN THE INTAKE AIR DUCT, CREATING A FIRE HAZARD IN THE EVENT OF A BACKFIRE. IF THIS OCCURS, MAINTAIN A CRANKING ACTION TO SUCK THE FLAMES INTO THE ENGINE. AN OUTSIDE ATTENDANT WITH A FIRE EXTINGUISHER IS ADVISED FOR COLD STARTS WITHOUT PREHEAT.

During cold weather operations, no indication will be apparent on the oil temperature gauge prior to takeoff if outside air temperatures are very cold. After a suitable warm-up period (2 to 5 minutes at 1000 RPM), accelerate the engine several times to higher engine RPM. If the engine accelerates smoothly and the oil pressure remains normal and steady, the airplane is ready for takeoff.

**FLIGHT OPERATIONS**

Takeoff is made normally with carburetor heat off and mixture set for prevailing altitude.

When operating in temperatures below -28°C (-18°F), avoid using partial carburetor heat. Partial heat may increase the carburetor air temperature to the 32°F (0°C) to 70°F (21°C) range, where icing is critical under certain atmospheric conditions. It is advisable to use either full heat or no heat.

**HOT WEATHER OPERATION**

The normal starting information in this section is appropriate. Avoid prolonged engine operation on the ground.

**NOISE ABATEMENT**

Public concern over environmental pollution has placed increased emphasis on control of airplane noise.

Revised: December 15, 1977

As Pilots, we can assist in reducing public exposure to airplane noise as follows:

- (1) When flying VFR over outdoor assemblies of persons, recreational areas or other noise-sensitive areas attempt to fly at least 2000 feet above the surface.
- (2) During climb out or descent to an airport attempt to plan the maneuver so that prolonged flight at low altitude can be minimized.

**NOTE**

The above recommended procedures do not apply where they would conflict with Air Traffic Control clearances or instructions, or where, in the pilot's judgment, an altitude of less than 2000 feet is necessary for him to adequately exercise his duty to see and avoid other airplanes.



## SECTION 5 PERFORMANCE

### TABLE OF CONTENTS

	Page
Introduction .....	5-3
Use of Performance Charts .....	5-3
Sample Problem .....	5-3
Conditions .....	5-3
Route of Trip .....	5-4
Takeoff .....	5-5
Time, Fuel and Distance to Climb .....	5-6
Cruise Performance .....	5-6
Landing .....	5-8
Figure 5-1. Airspeed Calibration .....	5-10
Figure 5-2. Temperature Conversion Chart .....	5-11
Figure 5-3. Altimeter Correction — Normal System .....	5-12
Figure 5-4. Altimeter Correction — Alternate System .....	5-13
Figure 5-5. Stall Speeds .....	5-14
Figure 5-6. Crosswind Component Chart .....	5-15
Figure 5-7. Takeoff Distance .....	5-16
Figure 5-8. Rate of Climb .....	5-17
Figure 5-9. Time, Fuel and Distance to Climb .....	5-18
Figure 5-10. Cruise Performance .....	5-19
Figure 5-11. Cruise Speeds .....	5-22
Figure 5-12. Range Profile — 37 Gallons Fuel .....	5-23
Figure 5-13. Range Profile — 51 Gallons Fuel .....	5-24
Figure 5-14. Endurance Profile — 37 Gallons Fuel .....	5-25
Figure 5-15. Endurance Profile — 51 Gallons Fuel .....	5-26
Figure 5-16. Short Field Landing Distance .....	5-27
Figure 5-17. Normal Landing Distance .....	5-28





## INTRODUCTION

The performance charts and tables presented on the following pages enable the pilot to know what to expect from the AA-5B airplane under various conditions. These charts also provide the pilot with a valuable aid in accurate flight planning, therefore they should be consulted prior to each flight.

These charts are a compilation of data obtained through actual flight tests conducted in an AA-5B airplane with an engine in good condition, and using average piloting techniques.

The performance in the range and endurance profile charts (Figures 5-12 through 5-15) allows for 45 minutes reserve fuel at 45% power. Fuel flow data for cruise (Figures 5-10 and 5-11) is based upon the recommended leaning procedure. Some variables, such as mixture leaning technique, engine and propeller condition, and air turbulence may affect range and endurance by 10% or more.

## USE OF PERFORMANCE CHARTS

The performance data is presented in tabular or graphical form, depending upon which presentation method best portrays the specific data. Each table or graph contains explanatory material when the use of the table or graph is not obvious. In addition, a sample problem, involving typical use of the performance data in this section, is presented, to illustrate usage of the tables and graphs.

## SAMPLE PROBLEM

A sample flight plan has been outlined below to show the use of the performance data presented in this section.

## CONDITIONS

### Origin — Norfolk, Nebraska (OFK)

Outside Air Temperature	68°F (20°C)
Field Elevation	1571 Ft.
Altimeter Setting	29.75 in. Hg.
Wind	110° at 10 Kts.
Runway 13 length	5800 Ft.
Initial Weight	2350 Lbs.

SECTION 5  
PERFORMANCE

GULFSTREAM AMERICAN  
MODEL AA-5B TIGER

Destination — Denver, Colorado (DEN)

Outside Air Temperature	50°F (10°C)
Field Elevation	5330 Ft.
Altimeter Setting	29.80 in. Hg.
Wind	360° at 20 Kts.
Runway 35 length	11,500 Ft.

ROUTE OF TRIP

Route Segment	Magnetic Course	Dist Nm	Wind 8500 Feet DIR/KTS	OAT 8500 Feet °C	Alt. Setting in. Hg.
OFK — OBH	220°	55	090/30	0	29.75
OBH — LBF	256°	111	090/30	0	29.75
LBF — SNY	261°	102	020/20	5	29.80
SNY — DEN	217°	110	020/20	5	29.80

ABBREVIATION

OFK  
OBH  
LBF  
SNY  
DEN

AIRPORT

Norfolk, Nebraska  
Wolbach, Nebraska  
North Platte, Nebraska  
Sidney, Nebraska  
Denver, Colorado

To determine pressure altitude at origin and destination airports, add 100 feet to field elevation for each .1 in. Hg. below 29.92, and subtract 100 feet from field elevation for each .1 in. Hg. above 29.92.

Pressure Altitude at OFK;  
 $29.92 - 29.75 = .17$  in. Hg.

The pressure altitude at OFK is 170 feet above the field elevation.  
 $1571 + 170 = 1741$  Ft.

Issued: September 30, 1976

Pressure Altitude at DEN  
 $29.92 - 29.80 = .12$  in. Hg.

The pressure altitude at DEN is 120 feet above the field elevation.  
 $5330 + 120 = 5450$  Ft.

**NOTE**

For flight planning, the difference between cruise altitude and pressure altitude has been ignored.

**TAKEOFF**

Using the conditions listed for Norfolk, Nebraska, the takeoff distance required can be found. It should be kept in mind that the distances shown are based on maximum performance techniques. Conservative distances can be established by reading the chart at the next higher value of weight, altitudes and temperature. For this sample problem, 2400 lbs., 2000 ft. pressure altitude, and 20°C should be used to determine the takeoff distance from Figure 5-7.

Ground roll . . . . .	1083 Feet
Total Distance to clear a 50-foot obstacle . . . . .	1926 Feet

A correction for the affect of wind may be made based on Note 1 of Takeoff Distance (Figure 5-7) Using Figure 5-6, the headwind component is determined to be 9.5 Knots.

The distance correction for a 9.5 Knot headwind is:

$$\frac{9.5 \text{ Knots}}{5 \text{ Knots}} \times 4\% = 8\% \text{ Decrease}$$

This results in the following distances, corrected for wind:

Ground roll, zero wind (feet) . . . . .	1083
Decrease in ground roll (1083 x 8%) . . . . .	-87
Corrected ground roll . . . . .	996
Total distance to clear a 50-foot obstacle, zero wind . . . . .	1926
Decrease in total distance (1926 x 8%) . . . . .	-154
Corrected total distance to clear a 50-foot obstacle . . . . .	1772

The distance is well within the takeoff distance available of 5800 Feet.

**SECTION 5  
PERFORMANCE**

**GULFSTREAM AMERICAN  
MODEL AA-5B TIGER**

**TIME, FUEL AND DISTANCE TO CLIMB:**

Enter the graph for Time, Fuel and Distance to Climb (Figure 5-9) at the initial altitude (1571 feet) and at the cruise altitude (8500 feet).

Time to Climb = 14 - 2 = 12 min  
 Fuel to Climb = 3 - .5 = 2.5 gal.  
 Distance Traveled = 22 - 3 = 19 N.M.

**CRUISE PERFORMANCE:**

Based on the distance required, cruise performance tables (Figure 5-10 and 5-11), and the range and endurance profiles (Figure 5-12 through 5-15), a power setting of 2600 RPM has been selected for this sample flight.

At 2600 RPM, enter the cruise performance tables at 8000 and 9000 feet, standard day and 20°C above standard.

STANDARD TEMPERATURE					
PRESSURE ALTITUDE FEET	TEMP	% BHP	TAS		FUEL FLOW
			KTS	MPH	GPH
8000	-1°C (31°F)	68	132	152	10.0
9000	-3°C	66	131	151	9.8
20°C ABOVE STANDARD TEMPERATURE					
PRESSURE ALTITUDE FEET	TEMP	% BHP	TAS		FUEL FLOW
			KTS	MPH	GPH
8000	19°C (67°F)	64	130	150	9.5
9000	17°C (63°F)	63	130	149	9.4

Interpolating for 8500 feet yields:

STANDARD TEMPERATURE					
PRESSURE ALTITUDE FEET	TEMP	% BHP	TAS		FUEL FLOW
			KTS	MPH	GPH
8500	-2°C (29°F)	67	132	152	9.9
20°C ABOVE STANDARD TEMPERATURE					
PRESSURE ALTITUDE FEET	TEMP	% BHP	TAS		FUEL FLOW
			KTS	MPH	GPH
8500	18°C (65°F)	63	130	150	9.5

Interpolating for the temperature of the appropriate route segment yields:

Route Segment	% BHP	TAS		Fuel Flow
		KTS	MPH	GPH
OFK - LBF	67	131	151	9.9
LBF - DEN	65	131	151	9.7

**NOTE**

The above are values for the assumed conditions.

Time and fuel used were calculated as follows:

$$\text{Time} = \frac{\text{Distance}}{\text{Ground Speed}}$$

$$\text{Fuel Used} = (\text{Time}) (\text{Fuel Flow})$$

Route Segment	Distance N.M.	Est. Ground Speed		Time at Cruise Altitude	Fuel Used For Cruise
		KTS	MPH	HRS:MIN	GAL
OFK - OBH	36*	150	173	:14	2.4
OBH - LBF	111	160	184	:42	6.9
LBF - SNY	102	141	162	:43	7.0
SNY - DEN	110	150	173	:44	7.1

\*Distance required to climb has been subtracted from segment distance.

SECTION 5  
PERFORMANCE

GULFSTREAM AMERICAN  
MODEL AA-5B TIGER

Time — Fuel — Distance

Item	Time HRS:MIN	Fuel GAL	Distance N.M.
Start, Runup, Taxi and Take-off	0:00	1.3	0
Acceleration Climb	:12	2.5	19
Cruise	2:23	23.4	359
Total	2:35	27.2	378

Total flight time: 2 hours, 35 minutes

Block speed: 378 NM ÷ 2 hours, 35 minutes = 146 knots

The estimated weight is determined by subtracting the fuel required for the trip from the initial takeoff weight:

Initial takeoff weight = 2350 Lbs.

Estimated fuel used from OFK to DEN = 27.3 gal. (163.2 Lbs.)

Estimated landing weight = 2350 — 163 = 2187 Lbs.

**LANDING**

The landing distance required is determined in a similar manner to the procedure used in determining takeoff distance. Using 2200 lbs., 6000 ft. and 10°C, the distance can be found from Figure 5-17.

Ground roll ..... 450 Feet  
Total distance to clear a 50 foot obstacle ..... 1499 Feet

A correction for the effect of wind may be made based on Note 1 of the landing chart. Using Figure 5-6, the headwind component is determined to be 19.4 Knots. The distance correction for 19.5 Knots headwind is:

$$\frac{19.5 \text{ Knots}}{5 \text{ Knots}} \times 3\% = 12\% \text{ Decrease}$$

The results is the following distances, corrected for wind.

Ground roll, zero wind (feet) . . . . .	.450
Decrease in ground roll (450 x 12%) . . . . .	-54
Corrected ground roll . . . . .	.396
Total landing distance to clear a 50-foot obstacle, zero wind . . . . .	1499
Decrease in total distance (1499 x 12%) . . . . .	-180
Corrected total distance to clear a 50-foot obstacle . . . . .	1319

This distance is well within the landing distance available of 11,500 feet.

AIRSPEED CALIBRATION

NOTES:

1. Indicated airspeed assumes zero instrument error.
2. Corrections are not affected by flap position.

KNOTS				MILES PER HOUR			
NORMAL STATIC SYSTEM		ALTERNATE STATIC SYSTEM		NORMAL STATIC SYSTEM		ALTERNATE STATIC SYSTEM	
IAS	CAS	IAS	CAS	IAS	CAS	IAS	CAS
50	50	50	46	60	60	60	55
60	60	60	56	70	70	70	65
70	71	70	66	80	81	80	75
80	81	80	76	90	91	90	85
90	91	90	86	100	101	100	95
100	101	100	96	110	111	110	105
110	111	110	106	120	121	120	115
120	121	120	115	130	131	130	125
130	131	130	125	140	141	140	135
140	141	140	135	150	151	150	144
150	151	150	145	160	161	160	154
160	162	160	155	170	171	170	164
170	172	170	165	180	181	180	174
180	182	180	175	190	192	190	184
				200	202	200	194
				210	212	210	204

Figure 5-1. Airspeed Calibration



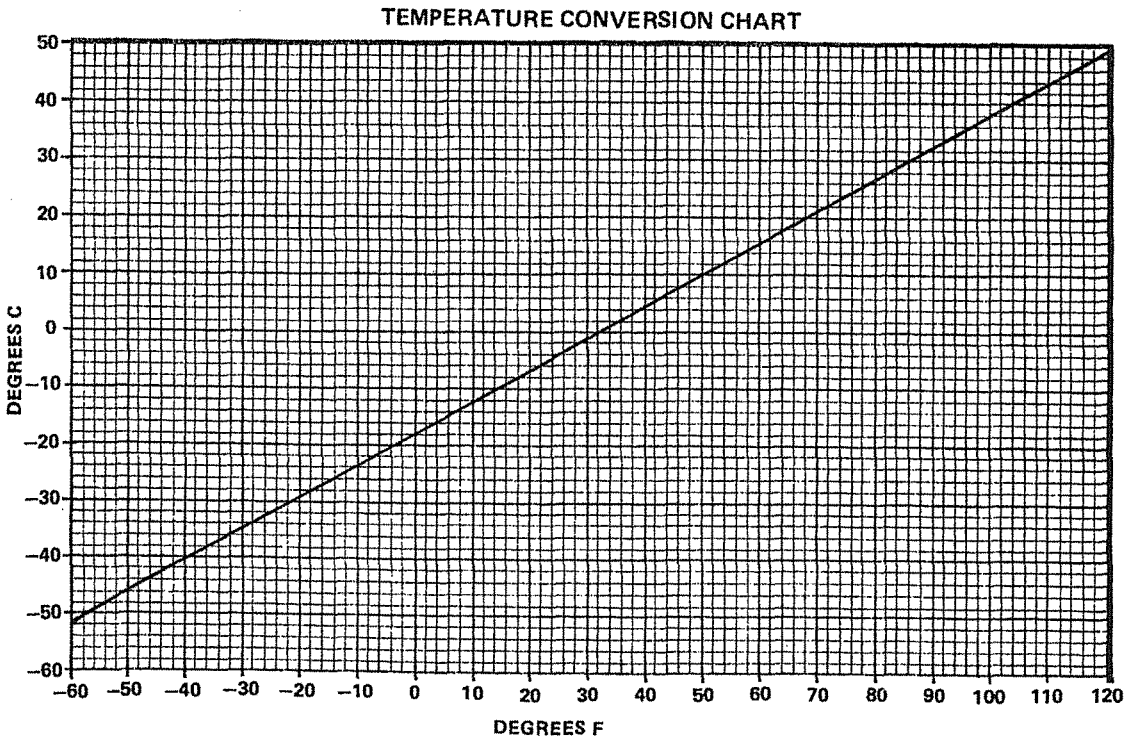

Figure 5-2. Temperature Conversion Chart

### ALTIMETER CORRECTION – NORMAL SYSTEM

**EXAMPLE:**

INDICATED AIRSPEED  $\text{—————}$  80 KNOTS (92 MPH)  
 INDICATED PRESSURE ALTITUDE  $\text{—————}$  6,000 FEET  
 ALTIMETER CORRECTION  $\text{—————}$  4 FEET  
 ACTUAL PRESSURE ALTITUDE = 6,000 + 4 = 6004 FEET

**NOTES**

1. Applicable for all flap positions.
2. Indicated airspeed and indicated altitude assume zero instrument error.

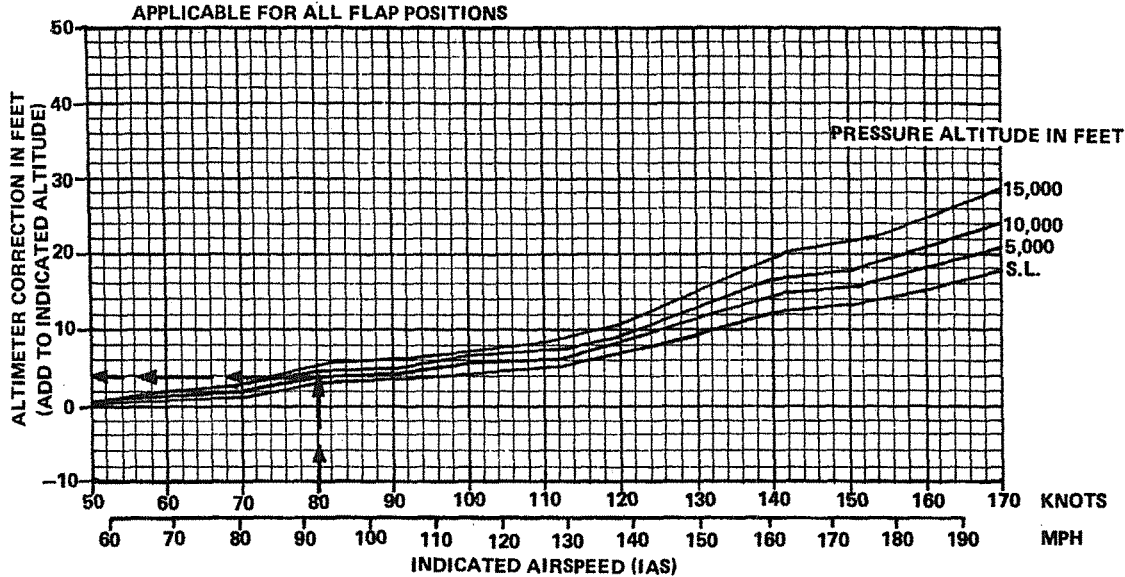

Figure 5-3. Altimeter Correction – Normal System

### ALTIMETER CORRECTION – ALTERNATE SYSTEM

**EXAMPLE:**

INDICATED AIRSPEED  $\text{---}$  80 KT. (92 MPH)

INDICATED PRESSURE ALTITUDE  $\text{---}$  6000 FEET

ALTIMETER CORRECTION  $\text{---}$  40 FEET

ACTUAL PRESSURE ALTITUDE = 6000 - 40 = 5960 FEET

**NOTES**

1. Applicable for all flap positions.
2. Indicated airspeed and indicated altitude assume zero instrument error.
3. Canopy and air vents closed.

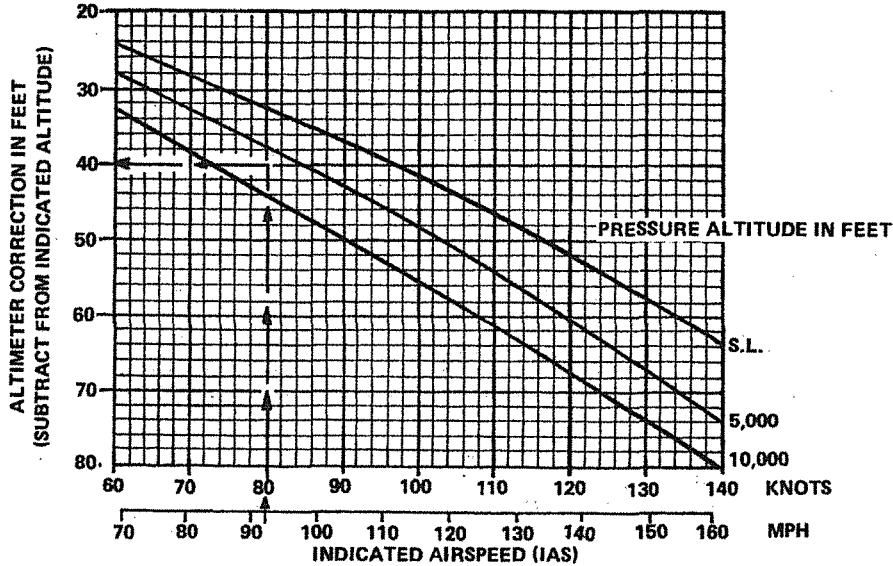

Figure 5-4. Altimeter Correction – Alternate System

## STALL SPEEDS - POWER IDLE

EXAMPLE  
 WEIGHT 2200LBS.  
 FLAPS 0 DEGREES  
 ANGLE OF BANK 30 DEGREES  
 STALL SPEED 60 KNOTS (69 MPH)

## NOTES

1. The maximum altitude lost in a normal stall recovery is approximately 350 feet.
2. Stall speeds apply for both calibrated and indicated airspeeds.

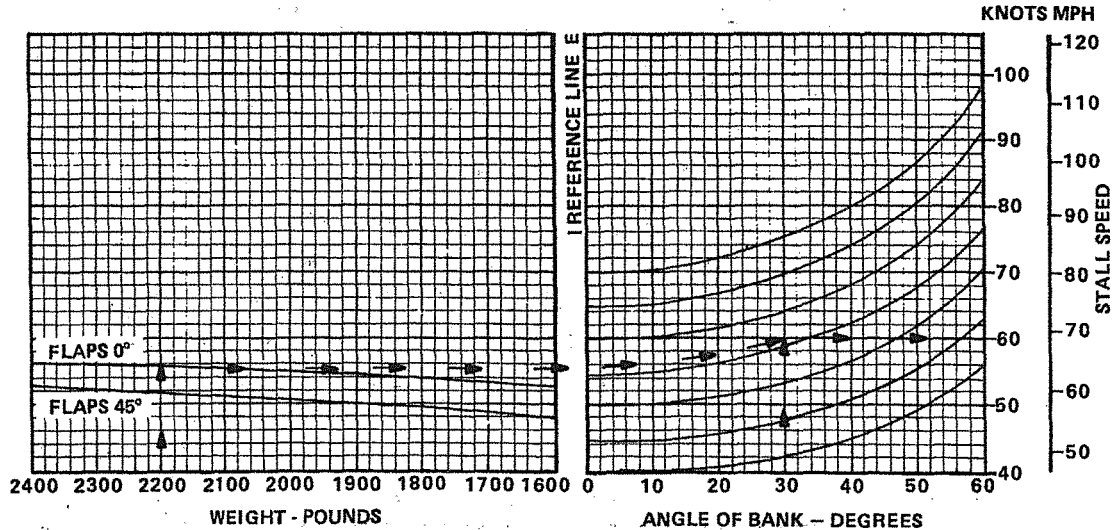

Figure 5-5. Stall Speeds

CROSSWIND COMPONENT CHART

EXAMPLE  
WIND SPEED 10 KNOTS  
ANGLE BETWEEN WIND  
DIRECTION AND FLIGHT PATH 20°  
HEADWIND COMPONENT 9.5 KNOTS  
CROSSWIND COMPONENT 3.5 KNOTS

NOTE  
Demonstrated crosswind component is 16 knots.

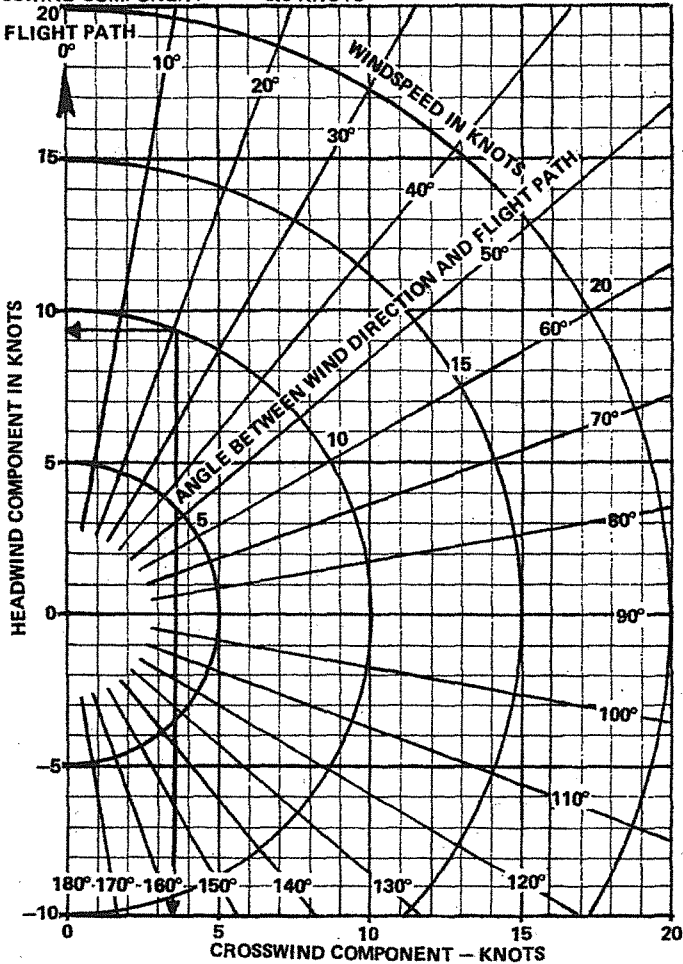

Figure 5-6. Crosswind Component Chart

Revised: July 15, 1978

SECTION 5  
PERFORMANCE

GULFSTREAM AMERICAN  
MODEL AA-5B TIGER

TAKEOFF DISTANCE

ASSOCIATED CONDITIONS:

Power – Maximum

Fuel Mixture – Full throttle climb, mixture leaned above 5000 feet to smooth engine operation.

Flaps – Up

Runway – Hard surface  
(level & dry)

NOTES:

1. Decrease distance 4% for each 5 knots headwind. For operation with tailwinds up to 10 knots increase distances by 8% for each 2.5 knots.
2. Where distance value is shaded, climb performance after lift-off, based on the engine operating at takeoff power at takeoff speed, is less than 150 feet per minute.
3. If takeoff power is set without brakes applied, then distances apply from point where full power is attained.

WEIGHT LBS.	TAKEOFF SPEED KIAS (MPH)		PRESS. ALT. FT.	0°C (32°F)			10°C (50°F)			20°C (68°F)			30°C (86°F)			40°C (104°F)		
	LIFT OFF	CLEAR 50 FT.		GROUND	ROLL	CLEAR 50 FT.	GROUND	ROLL	CLEAR 50 FT.	GROUND	ROLL	CLEAR 50 FT.	GROUND	ROLL	CLEAR 50 FT.	GROUND	ROLL	CLEAR 50 FT.
2400	57 (66)	65 (75)	S.L.	741	1331	822	1474	909	1628	1002	1792	1101	1966					
			2000	882	1574	979	1744	1083	1926	1193	2120	1311	2326					
			4000	1053	1867	1169	2069	1292	2284	1424	2514	1564	2758					
			6000	1260	2220	1398	2460	1546	2716	1704	2989	1873	3290					
			8000	1512	2646	1676	2932	1855	3237	2045	3563	2247	3600					
2200	55 (63)	63 (73)	S.L.	601	1088	667	1206	738	1332	813	1465	894	1608					
			2000	716	1287	795	1427	879	1575	968	1734	1064	1902					
			4000	854	1527	948	1692	1049	1868	1156	2056	1270	2256					
			6000	1022	1815	1135	2011	1255	2221	1383	2444	1520	2682					
			8000	1727	2163	1361	2398	1506	2647	1660	2913	1823	3197					
2000	52 (60)	61 (70)	S.L.	478	873	531	968	587	1068	647	1176	711	1290					
			2000	570	1033	632	1145	699	1264	770	1391	846	1526					
			4000	680	1225	754	1357	834	1499	920	1649	1010	1809					
			6000	813	1456	903	1613	998	1782	1100	1961	1209	2151					
			8000	976	1735	1083	1923	1198	2123	1320	2337	1450	2564					

Figure 5-7. Takeoff Distance

Revised: July 15, 1978

RATE OF CLIMB

ASSOCIATED CONDITIONS:

Power-----Maximum

Flaps-----Up

Fuel Mixture--Full throttle climb, mixture leaned above 5000 feet to smooth engine operation.

WEIGHT LBS	PRESSURE ALTITUDE FT	CLIMB SPEED		RATE-OF-CLIMB IN FT. PER MIN			
		KIAS	MPH	-20°C	0°C	20°C	40°C
				(-4°F)	(32°F)	(68°F)	(104°F)
2400	S.L.	90	104	1125	950	808	690
	2000	88	101	979	816	683	574
	4000	86	99	833	682	558	457
	6000	83	96	688	547	434	340
	8000	81	93	542	413	309	224
	10000	79	90	397	278	184	108
2200	S.L.	88	101	1272	1088	938	815
	2000	86	99	1119	946	807	693
	4000	84	97	965	805	676	571
	6000	82	94	811	663	545	449
	8000	79	91	657	522	414	328
	10000	77	89	503	380	283	206
2000	S.L.	86	99	1447	1250	1091	961
	2000	84	97	1283	1100	953	833
	4000	82	94	1119	950	814	704
	6000	80	92	955	800	676	576
	8000	77	89	791	649	537	448
	10000	75	86	627	499	399	320

Figure 5-8. Rate of Climb

### TIME FUEL AND DISTANCE TO CLIMB

**EXAMPLE:**

AIRPORT ALTITUDE **1571 FT.**  
 CRUISE ALTITUDE **8500 FT.**  
 TIME TO CLIMB (14-2) **12 MIN.**  
 FUEL TO CLIMB (3-5) **2.5 GAL. (15 LB)**  
 DISTANCE TO CLIMB (22-3) **19 NM (22 SM)**

**ASSOCIATED CONDITIONS:**

POWER **FULL THROTTLE**  
 MIXTURE **RECOMMENDED LEANING SCHEDULE**  
 CLIMB SPEEDS **IAS AS SCHEDULED**  
 TEMPERATURE **STANDARD DAY (ISA)**  
 FUEL DENSITY **6.0 LBS. PER U.S. GAL.**  
 WEIGHT **2400 LBS.**

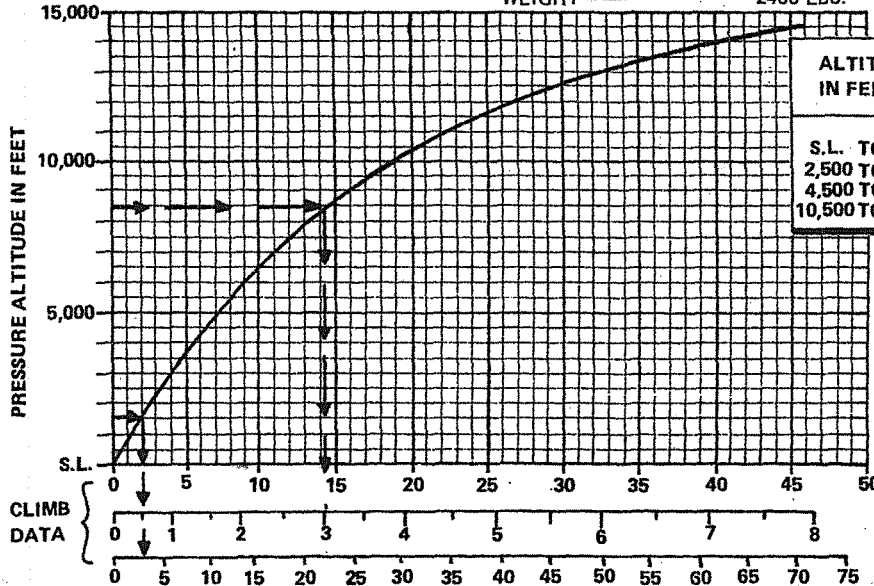

ALTITUDE IN FEET	CLIMB SPEED	
	KTS	MPH
S.L. TO 2,500	90	104
2,500 TO 4,500	85	100
4,500 TO 10,000	80	95
10,500 TO 14,500	75	90

NOTE: Add 8 pounds of fuel for start, taxi, and takeoff.

TIME(MIN)  
 FUEL(GAL)  
 DIST.(NM)

Figure 5-9. Time Fuel and Distance to Climb



CRUISE PERFORMANCE

CONDITIONS:

Recommended lean mixture, weight 2400 pounds.

PRESSURE ALTITUDE 2000 FEET												
RPM	20°C BELOW STD. TEMP -9°C (16°F)				STANDARD TEMP 11°C (52°F)				20°C ABOVE STD. TEMP 31°C (88°F)			
	%	TAS	TAS	FUEL	%	TAS	TAS	FUEL	%	TAS	TAS	FUEL
	BHP	KTS	MPH	GPH	BHP	KTS	MPH	GPH	BHP	KTS	MPH	GPH
2700	96	142	163	14.4	89	141	162	13.3	88	140	161	13.1
2600	85	136	156	12.6	79	135	155	11.2	75	134	154	10.7
2500	76	130	149	10.9	71	129	148	10.4	67	128	147	10.0
2400	68	124	142	10.0	63	122	141	9.5	60	121	140	9.2
2300	60	117	135	9.2	57	115	132	8.7	54	113	131	8.4
2200	54	110	126	8.4	51	108	124	8.1	49	107	123	7.9
PRESSURE ALTITUDE 3000 FEET												
	-11°C (12°F)				9°C (48°F)				29°C (84°F)			
2700	93	141	163	13.9	86	141	162	12.8	81	140	161	12.0
2600	83	135	156	12.3	77	134	155	11.0	73	134	154	10.6
2500	74	129	148	10.6	70	128	148	10.2	66	127	146	9.7
2400	67	123	142	9.9	62	122	140	9.4	59	120	138	9.0
2300	59	117	134	9.0	56	115	132	8.6	53	113	130	8.3
2200	53	109	125	8.3	50	107	123	8.0	48	105	121	7.8
PRESSURE ALTITUDE 4000 FEET												
	-13°C (9°F)				7°C (45°F)				27°C (81°F)			
2700	90	141	162	13.4	84	140	161	12.5	78	139	160	11.1
2600	81	135	156	12.0	75	134	154	10.8	72	134	154	10.4
2500	72	129	148	10.5	68	129	148	10.0	64	127	146	9.6
2400	65	123	142	9.6	61	121	140	9.2	58	120	138	8.8
2300	58	116	134	8.9	54	114	131	8.5	52	112	129	8.2
2200	51	108	125	8.1	49	107	123	7.9	47	103	119	7.6
PRESSURE ALTITUDE 5000 FEET												
	-15°C (5°F)				5°C (41°F)				25°C (77°F)			
2700	87	141	162	13.0	81	140	161	12.0	77	139	160	10.9
2600	78	134	155	11.1	74	134	154	10.6	69	132	152	10.1
2500	71	129	148	10.3	66	127	146	9.7	62	125	144	9.3
2400	63	122	141	9.5	59	120	138	9.0	56	119	137	8.7
2300	56	115	132	8.7	53	113	130	8.3	51	112	129	8.1
2200	50	108	124	8.0	48	106	121	7.8	46	104	119	7.6

Figure 5-10. Cruise Performance (Sheet 1 of 3)

CRUISE PERFORMANCE

CONDITIONS:

Recommended lean mixture, weight 2400 pounds.

NOTE:

Shaded area represents operation with full throttle.

PRESSURE ALTITUDE 6000 FEET												
RPM	20° BELOW STD. TEMP. -17°C (2°F)				STANDARD TEMP. 3°C (38°F)				20° ABOVE STD. TEMP. 23°C (74°F)			
	%	TAS	TAS	FUEL	%	TAS	TAS	FUEL	%	TAS	TAS	FUEL
	BHP	KTS	MPH	GPH	BHP	KTS	MPH	GPH	BHP	KTS	MPH	GPH
2700	85	141	162	12.6	79	139	160	11.2	75	139	160	10.8
2600	76	134	154	10.9	72	134	154	10.4	67	132	152	9.9
2500	69	129	148	10.1	64	127	146	9.6	61	125	144	9.2
2400	61	122	140	9.3	58	120	138	8.9	55	117	135	8.5
2300	55	114	131	8.5	52	112	129	8.2	50	110	127	8.0
2200	49	107	123	7.9	47	104	119	7.6	45	102	118	7.5
PRESSURE ALTITUDE 7000 FEET												
	-19°C (-2°F)				1°C (34°F)				21°C (70°F)			
2700	83	140	161	12.3	77	139	160	11.0	73	138	159	10.5
2600	74	134	154	10.7	70	133	153	10.2	66	131	151	9.7
2500	67	128	147	9.9	63	126	145	9.4	59	124	143	9.0
2400	60	121	139	9.1	56	119	137	8.7	54	117	135	8.4
2300	53	113	130	8.4	51	112	129	8.1	48	108	124	7.8
2200	49	107	123	7.8	46	103	119	7.6	45	102	117	7.4
PRESSURE ALTITUDE 8000 FEET												
	21°C (-6°F)				-1°C (31°F)				19°C (67°F)			
2700	80	136	160	11.2	75	139	160	10.8	71	137	158	10.3
2600	72	134	154	10.5	68	132	152	10.0	64	130	150	9.5
2500	65	127	146	9.7	61	125	144	9.2	58	123	142	8.9
2400	58	120	138	8.9	55	118	136	8.6	53	117	134	8.3
2300	53	113	129	8.3	50	111	128	8.0	48	109	125	7.8
2200	48	105	121	7.8	46	103	118	7.5	45	102	117	7.4
PRESSURE ALTITUDE 9000 FEET												
	-23°C (-9°F)				-3°C (27°F)				17°C (63°F)			
2700	76	136	158	10.9	72	138	158	10.5	69	137	157	10.1
2600	71	134	154	10.4	66	131	151	9.8	63	130	149	9.4
2500	63	126	145	9.5	60	124	143	9.1	57	123	141	8.7
2400	57	119	137	8.8	54	117	135	8.4	52	115	132	8.2
2300	52	112	129	8.2	49	108	125	7.8	47	107	123	7.7
2200	46	103	119	7.6	45	102	117	7.4	45	101	117	7.4

Figure 5-10. Cruise Performance (Sheet 2 of 3)

CRUISE PERFORMANCE

CONDITIONS:

Recommended lean mixture, weight 2400 pounds.

NOTE:

Shaded area represents operation with full throttle. (F.T.)

PRESSURE ALTITUDE 10,000 FEET												
RPM	20° BELOW STD. TEMP. -25°C (-13°F)				STANDARD TEMP. -5°C (23°F)				20° ABOVE STD. TEMP. 15°C (59°F)			
	%	TAS	TAS	FUEL	%	TAS	TAS	FUEL	%	TAS	TAS	FUEL
	BHP	KTS	MPH	GPH	BHP	KTS	MPH	GPH	BHP	KTS	MPH	GPH
2700	72	136	156	10.5	69	136	156	10.2	67	135	155	9.9
2600	68	132	152	10.0	64	130	150	9.6	61	129	148	9.2
2500	62	125	144	9.3	58	123	142	8.9	56	123	141	8.6
2400	56	118	136	8.6	53	117	135	8.3	50	113	130	8.0
2300	51	112	129	8.1	48	108	125	7.8	47	106	122	7.7
2200	46	104	120	7.6	45	102	117	7.4	45	101	116	7.4
PRESSURE ALTITUDE, 11,000 FEET												
	-27°C (-16°F)				-7°C (20°F)				13°C (45°F)			
F.T.	70	134	154	10.2	67	134	154	9.9	65	134	154	9.7
2600	67	132	152	9.9	63	130	150	9.5	60	129	148	9.1
2500	61	125	144	9.2	57	123	141	8.8	54	120	139	8.5
2400	55	117	135	8.5	52	115	133	8.2	50	114	131	8.0
2300	50	110	126	8.0	47	107	123	7.7	47	106	122	7.6
2200	45	102	117	7.5	45	101	117	7.4	45	101	116	7.4
PRESSURE ALTITUDE 12,000 FEET												
	-29°C (-20°F)				-9°C (16°F)				11°C (52°F)			
F.T.	67	132	152	9.8	64	132	152	9.6	62	132	152	9.4
2600	65	131	151	9.7	61	129	148	9.3	58	128	147	8.9
2500	59	124	142	9.0	56	123	141	8.7	53	118	136	8.3
2400	54	117	135	8.4	50	113	130	8.0	49	111	128	7.9
2300	48	108	124	7.8	47	106	122	7.7	47	106	122	7.6
2200	45	102	117	7.4	45	101	116	7.4	45	101	116	7.4
PRESSURE ALTITUDE 13,000 FEET												
	-31°C (-24°F)				-11°C (13°F)				9°C (49°F)			
F.T.	64	130	150	9.5	62	130	150	9.3	60	130	150	9.1
2600	64	130	150	9.5	60	128	147	9.1	57	127	146	8.8
2500	58	123	142	8.9	55	121	139	8.5	52	118	136	8.2
2400	52	116	133	8.3	50	114	131	8.0	49	111	127	7.8
2300	48	109	125	7.8	47	106	122	7.6	47	106	122	7.6
2200	45	101	117	7.4	45	101	116	7.4	45	100	115	7.4

Figure 5-10. Cruise Performance (Sheet 3 of 3)

**CRUISE SPEEDS**

**EXAMPLE:**

PRESSURE ALT. — 8500 FT  
 POWER SETTING — 67% MCP  
 TRUE AIRSPEED — 132 KNOTS  
 (152 MPH)

**ASSOCIATED CONDITIONS:**

CRUISE WEIGHT — 2400 LB.  
 TEMPERATURE — STANDARD  
 DAY ISA

**NOTE**

Cruise speeds are shown for airplane equipped with speed fairings which increase speeds by approximately 3.5 knots (4 MPH).

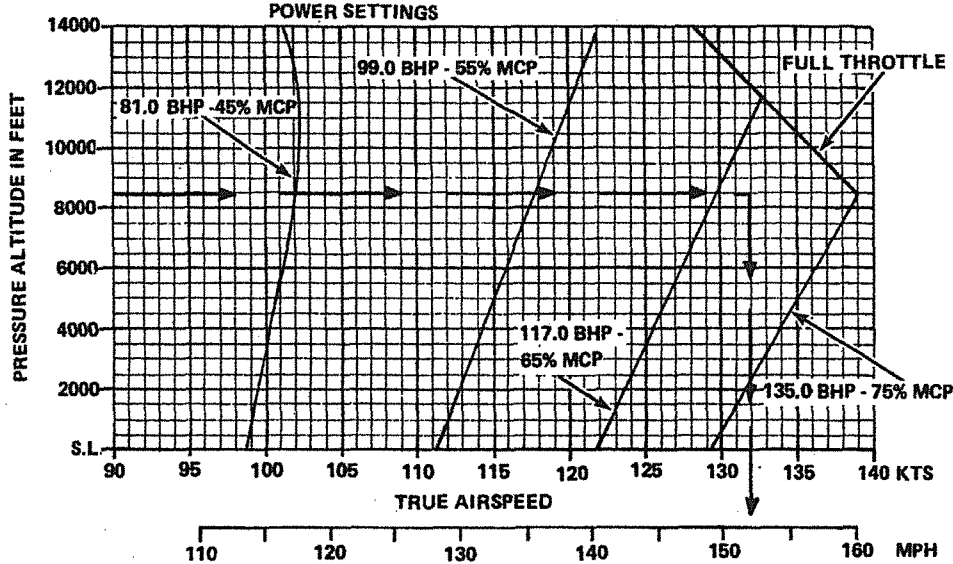

Figure 5-11. Cruise Speeds

**RANGE PROFILE — 37 GALLONS FUEL**

**EXAMPLE:**

PRESSURE ALT. — 8500 FT.  
 POWER SETTING — 65 % MCP  
 RANGE — 385 NM  
 (443 SM)

**ASSOCIATED CONDITIONS:**

WEIGHT — 2400 LB. AT START  
 FUEL — AV. GAS.  
 FUEL DENSITY — 6.0 LB/GAL.  
 FUEL LOADING — 37 U.S. GAL.  
 MIXTURE — RECOMMENDED  
 LEANING SCHEDULE

**NOTES:**

1. Range includes start, taxi and climb with 45 minutes reserve at 45% MCP.
2. Cruise speeds are shown for airplane equipped with wheel fairings which increase speeds by approximately 3.5 knots (4 MPH).

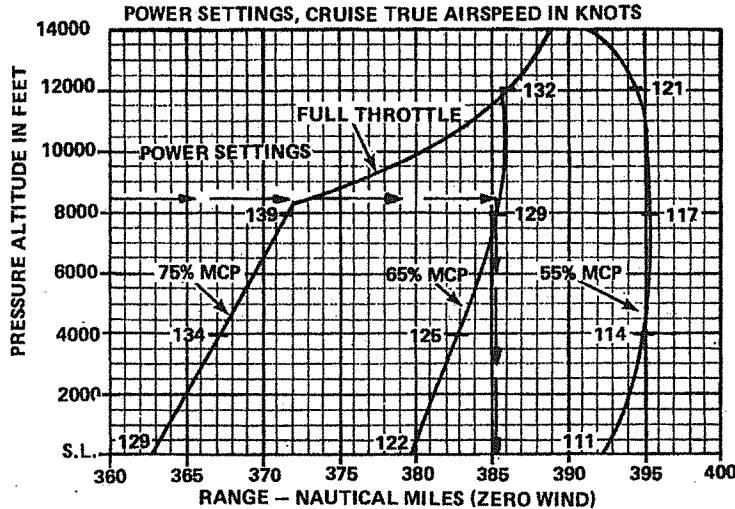

Figure 5-12. Range Profile-37 Gallons Fuel

### RANGE PROFILE - 51 GALLONS FUEL

#### EXAMPLE:

PRESSURE ALT. — 8500 FT.  
 POWER SETTING — 67% MCP  
 RANGE — 569 NM  
 (655 SM)

#### ASSOCIATED CONDITIONS:

WEIGHT — 2400 LB. AT  
 START  
 FUEL — AV. GAS.  
 FUEL DENSITY — 6.0 LB/GAL.  
 FUEL LOADING — 51 U.S. GAL.  
 MIXTURE — RECOMMENDED  
 LEANING  
 SCHEDULE

#### NOTE

1. Range includes start, taxi and climb with 45 minutes reserve at 45% MCP.
2. Cruise speeds are shown for airplane equipped with wheel fairings which increase speeds by approximately 3.5 knots (4 MPH).

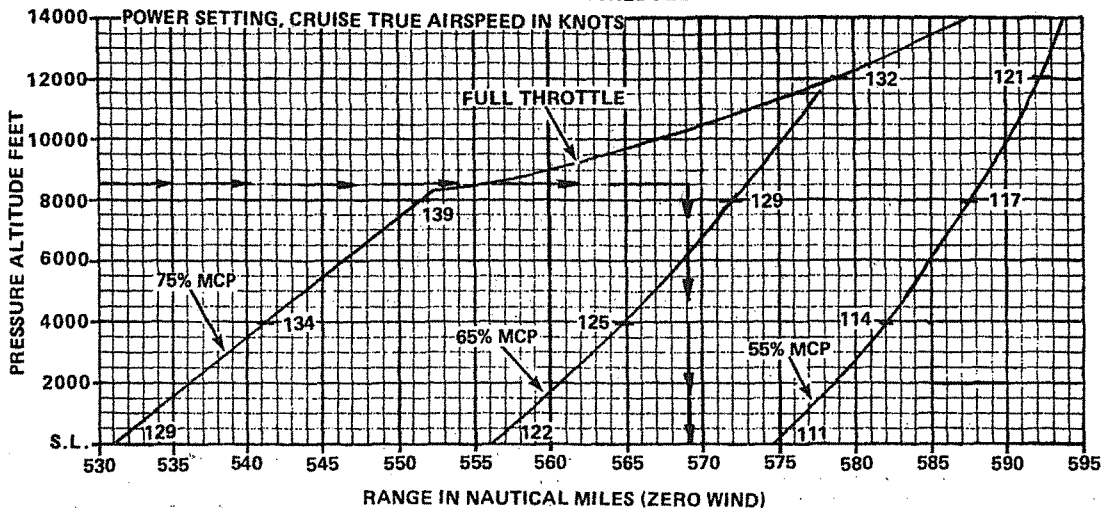

Figure 5-13. Range Profile - 51 Gallons Fuel

Revised: December 15, 1977

### ENDURANCE PROFILE — 37 GALLONS FUEL

**EXAMPLE:**  
 PRESSURE ALT. 8500 FT  
 POWER SETTING 65% MCP  
 ENDURANCE 3 HR. 2 MIN

**ASSOCIATED CONDITIONS:**

WEIGHT 2400 LB AT START  
 FUEL AV. GAS.  
 FUEL DENSITY 6.0 LB/GAL  
 FUEL LOADING 37 U.S. GAL.  
 MIXTURE RECOMMENDED  
 LEANING SCHEDULE

**NOTES**

1. Endurance includes start, taxi and climb with 45 minutes reserve at 45% MCP.
2. Cruise speeds are shown for airplane equipped with wheel fairings which increase speeds by approximately 3.5 knots (4 MPH).

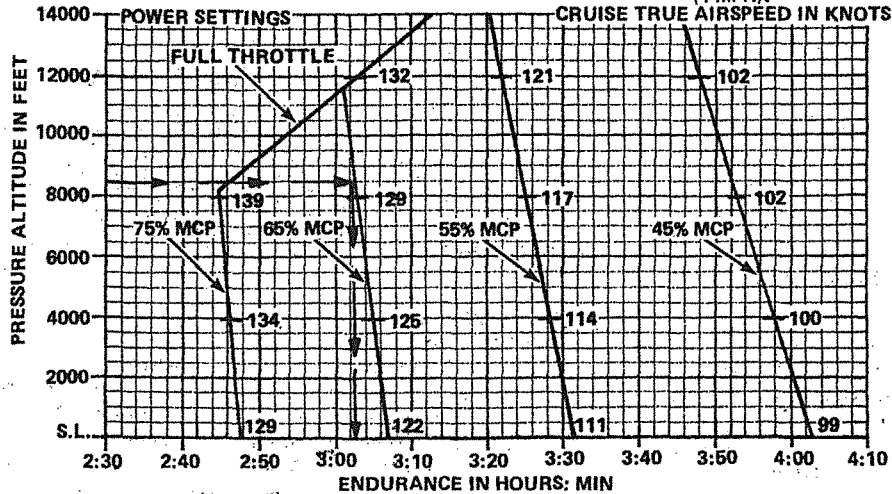

Figure 5-14. Endurance Profile — 37 Gallons Fuel

## ENDURANCE PROFILE - 51 GALLONS FUEL

## EXAMPLE:

PRESSURE ALT. — 8500 FT  
 POWER SETTING — 67% MCP  
 ENDURANCE — 4 HR.,  
                   23 MIN.

## ASSOCIATED CONDITIONS:

WEIGHT — 2400 LB. AT START  
 FUEL — AV. GAS.  
 FUEL DENSITY — 6.0 LB/GAL  
 FUEL LOADING — 51 U.S. GAL.  
 MIXTURE — RECOMMENDED  
 LEANING SCHEDULE

## NOTES:

- Endurance includes start, taxi and climb with 45 minutes reserve at 45% MCP.
- Cruise speeds are shown for airplane with wheel fairings which increase speeds by approximately 3.5 knots (4 MPH)

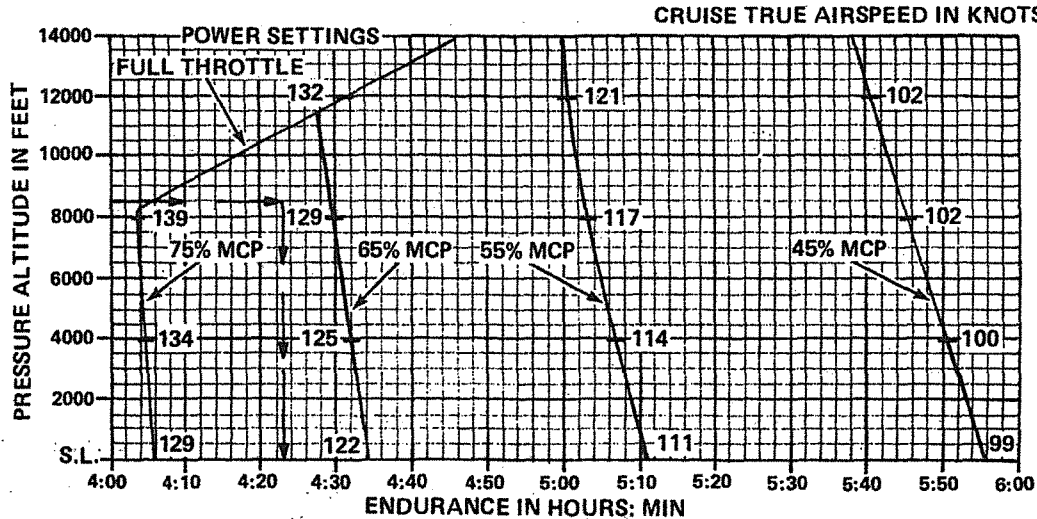

Figure 5-15. Endurance Profile - 51 Gallons Fuel



**SHORT FIELD LANDING DISTANCE**

**ASSOCIATED CONDITIONS:**

- Power — Off
- Flaps — Down
- Runway — Hard surface (level & dry)
- Braking — Maximum

**NOTES:**

1. Decrease distances 3% for each 5 knots headwind.
2. For operations with tailwinds up to 10 knots increase distances by 9% for each 2.5 knots.

WEIGHT LBS	SPEED AT 50 FT.		PRESS. ALT. FT.	0°C (32°F)		10°C (50°F)		20°C (68°F)		30°C (86°F)		40°C (104°F)	
	KIAS	MPH		GROUND ROLL	CLEAR 50 FT.	GROUND ROLL	CLEAR 50 FT.	GROUND ROLL	CLEAR 50 FT.	GROUND ROLL	CLEAR 50 FT.	GROUND ROLL	CLEAR 50 FT.
2400	63	73	S.L.	395	1076	405	1105	415	1135	426	1165	437	1196
			2000	416	1137	427	1169	439	1202	451	1236	463	1269
			4000	440	1205	453	1241	466	1278	479	1315	492	1352
			6000	467	1282	481	1322	496	1362	510	1403	525	1444
			8000	498	1369	514	1413	530	1457	546	1502	562	1548
2200	62	71	S.L.	371	1008	380	1035	389	1062	399	1089	409	1117
			2000	390	1063	400	1093	411	1123	422	1153	433	1184
			4000	412	1125	423	1158	435	1191	447	1225	459	1259
			6000	437	1195	450	1232	463	1268	476	1306	489	1343
			8000	465	1274	479	1314	493	1355	508	1396	523	1437
2000	61	70	S.L.	347	939	355	962	363	987	372	1011	380	1036
			2000	364	988	373	1015	382	1041	392	1069	402	1097
			4000	383	1044	394	1073	404	1103	415	1134	426	1164
			6000	405	1107	417	1140	429	1173	441	1207	453	1240
			8000	431	1178	444	1214	457	1251	470	1288	483	1326

Figure 5-16. Short Field Landing Distance

SECTION 5  
PERFORMANCE

GULFSTREAM AMERICAN  
MODEL AA-5B TIGER

NORMAL LANDING DISTANCE

ASSOCIATED CONDITIONS:

- Power – Off
- Flaps – Down
- Runway – Hard surface (level & dry)
- Braking – Maximum

NOTES:

1. Decrease distance 3% for each 5 knots headwind.
2. For operations with tailwinds up to 10 knots, increase distances by 9% for each 2.5 knots.

WEIGHT LBS	SPEED AT 50 FT.		PRESS. ALT. FT.	0°C (32°F)		10°C (50°F)		20°C (68°F)		30°C (86°F)		40°C (104°F)			
	KIAS	MPH		GROUND	ROLL	CLEAR 50 FT.	GROUND	ROLL	CLEAR 50 FT.	GROUND	ROLL	CLEAR 50 FT.	GROUND	ROLL	CLEAR 50 FT.
2400	69	78	S.L.	395	1305	405	1342	415	1379	426	1416	437	1454		
			2000	416	1381	427	1421	439	1462	451	1504	463	1546		
			4000	440	1466	453	1511	466	1556	479	1602	492	1648		
			6000	467	1561	481	1611	496	1661	510	1712	525	1763		
			8000	498	1669	514	1723	530	1779	546	1834	562	1890		
2200	67	77	S.L.	371	1220	380	1254	389	1287	399	1321	409	1356		
			2000	390	1289	400	1326	411	1363	422	1401	433	1439		
			4000	412	1367	423	1407	435	1449	447	1490	459	1533		
			6000	437	1454	450	1499	463	1544	476	1590	489	1437		
			8000	465	1551	479	1601	493	1651	508	1702	523	1753		
2000	66	76	S.L.	346	1134	355	1164	363	1194	372	1224	380	1256		
			2000	364	1196	373	1229	382	1262	392	1296	402	1331		
			4000	383	1265	394	1302	404	1339	415	1377	426	1415		
			6000	405	1394	417	1385	429	1426	441	1467	453	1509		
			8000	431	1432	444	1477	456	1522	470	1568	483	1614		

Figure 5-17. Normal Landing Distance

## SECTION 6 WEIGHT & BALANCE / EQUIPMENT LIST

### TABLE OF CONTENTS

	Page
Introduction .....	6-3
Airplane Weighing Procedures .....	6-3
Preparation .....	6-3
Leveling the Airplane .....	6-3
Weighing the Airplane .....	6-3
Measuring Arm .....	6-4
Computing Center of Gravity .....	6-6
Weight and Balance .....	6-6
Cargo Loading .....	6-10
Equipment List .....	6-15



## INTRODUCTION

This section contains the procedure for determining the basic empty weight and moment of the AA-5B airplane. Sample forms and the corresponding procedure for their use are provided to enable a rapid calculation of the weight and moment for various operations. A list of most commonly installed equipment for the AA-5B airplane is also provided.

It should be remembered that specific information on weight, arm, moment and installed equipment for this airplane can only be found in the appropriate weight and balance records carried in the airplane.

## AIRPLANE WEIGHING PROCEDURES

### PREPARATION

- (1) Inflate all tires to recommended operating pressure.
- (2) Drain all fuel from the tanks and fuel system.
- (3) Drain all oil from the oil system.
- (4) Move sliding seats to center of travel position.
- (5) Raise flaps to fully retracted position.
- (6) Place all controls in neutral position.
- (7) Ensure that all objects not a part of the airplane or its accessories are removed from the airplane.
- (8) Slide canopy to provide a 6-inch opening between canopy and windshield.

### LEVELING THE AIRPLANE

- (1) Place scales under each wheel (minimum capacity 1500 pounds for nose wheel and 1000 pounds capacity for main wheels), with a 1-inch thick wooden block between each wheel and the scale.
- (2) Place carpenter's levels on canopy track as shown in Figure 6-1.
- (3) Level airplane both laterally and longitudinally by deflating one or two tires until the bubbles in the levels center.

### WEIGHING THE AIRPLANE

- (1) Remove the levels, and close canopy.
- (2) With airplane level and brakes released, record the weight shown on each scale as shown in Figure 6-2.
- (3) Deduct tare (chocks, etc.), if any, from the scale readings and record the result in the weighing form.

MEASURING ARM

- (1) Obtain measurement A (Figure 6-2) as follows:
  - A. Stretch a string laterally across the airplane from the axle center of one main landing gear to the axle center of the other.
  - B. Connect a plumb bob such that it hangs from the engine firewall to the floor.
  - C. Using a tape, measure the distance from the plumb bob to the string stretched between the main landing gear.

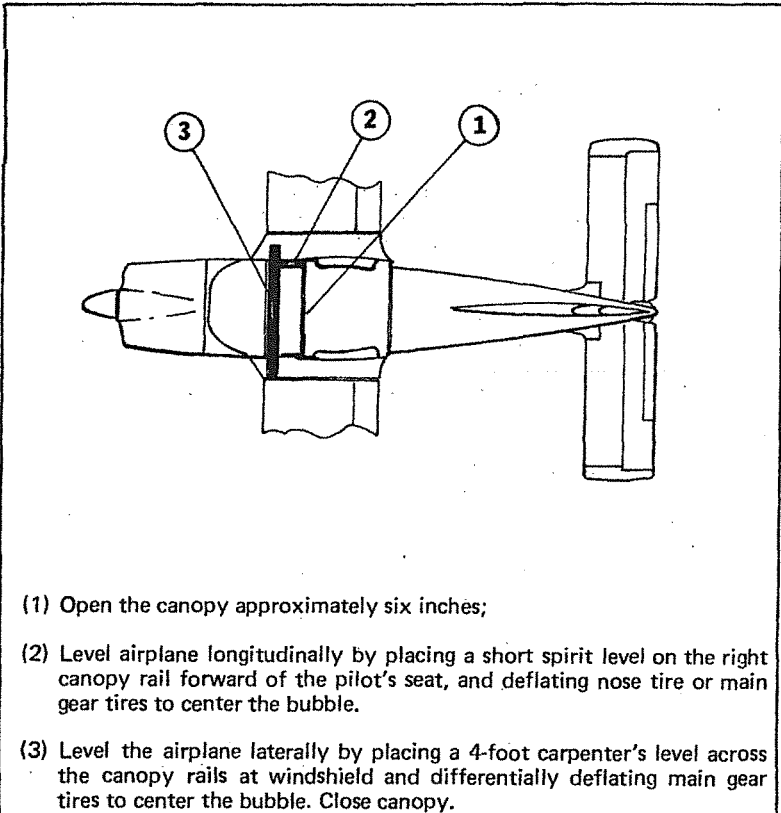
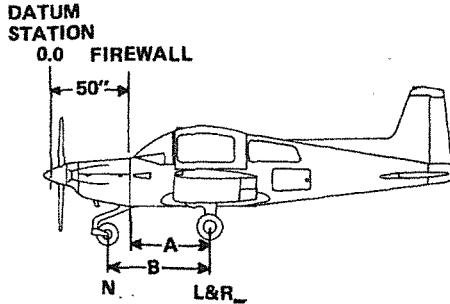

Figure 6-1. Airplane Leveling



Scale Position	Scale Reading	Tare	Symbol	Net Weight
Left Wheel			L	
Right Wheel			R	
Nose Wheel			N	
Total of Net Weights			W	

Calculate Arm (in inches) as follows:

NOTE

- (50 + A) = MAIN LANDING GEAR ARM (IN INCHES)
- 50 - (B - A) = NOSE LANDING GEAR ARM (IN INCHES)
- L = WEIGHT OF LEFT MAIN LANDING GEAR (IN POUNDS)
- R = WEIGHT OF RIGHT MAIN LANDING GEAR (IN POUNDS)
- N = WEIGHT OF NOSE LANDING GEAR (IN POUNDS)

$$\text{C. G. Arm} = \frac{[(50 + A) (L + R)] + [50 - (B - A)] N}{L + R + N}$$

Item	Weight	C.G. Arm	Moment/ 1000 Lbs. In.
Airplane Net Weight (W)			
Oil, 8 Qt. at 1.875 Lb./Qt.	15.0	32.0	.48
Unusable Fuel 1.6 Gal. at 6 Lb./Gal.	9.6	94.8	.91
Equipment Changes			
Airplane Basic Empty Weight			

Figure 6-2. Sample Airplane Weighing

**SECTION 6  
WEIGHT & BALANCE/  
EQUIPMENT LIST**

**GULFSTREAM AMERICAN  
MODEL AA-5B TIGER**

- D. Record measurement A in the weighing form (Figure 6-2).
- (2) Obtain Measurement B (Figure 6-2) as follows:
  - A. Ensure that the nose wheel is set straight along the centerline of the airplane.
  - B. Using a tape, measure from the center of the nose gear axle to the string stretched between the main landing gear wheels.
  - C. Record measurement B in the Weighing Form (Figure 6-2).

**COMPUTING CENTER OF GRAVITY**

- (1) Using the weights previously recorded, calculate the airplane net weight (W), per Figure 6-2.
- (2) Using the weights and measurements previously recorded, calculate the C.G. Arm according to the formula in Figure 6-2.
- (3) Enter the airplane net weight (W) and C.G. Arm obtained in Steps (1) and (2) in the Airplane Basic Empty Weight Form at the bottom of Figure 6-2.
- (4) Obtain moment by multiplying weight times C.G. Arm and dividing by 1000. Enter moment in the appropriate column.
- (5) Add the entries in the weight column to obtain the AIRPLANE BASIC EMPTY WEIGHT.
- (6) Add the entries in the MOMENT/1000 Lbs. In. column to obtain the AIRPLANE BASIC EMPTY WEIGHT MOMENT.

**WEIGHT AND BALANCE**

The following information will enable you to fly your AA-5B within the prescribed weight and center of gravity limitations. To calculate the weight and balance for your AA-5B, use the Sample Problem (Figure 6-3), Loading Graph (Figure 6-4) and Center of Gravity Envelope (Figure 6-5) charts as follows:

Write down the "Licensed Empty Weight" and "Moment" on the Sample Loading Problem chart (Figure 6-3) under the column marked "your airplane" from the Weight and Balance Data sheet (and/or changes listed on FAA Form 337) included with your airplane papers. Also add all additional weights and their corresponding moments (obtained from the "loading graph") of items to be carried on the flight. Plot the total weight and moment on the "Center of Gravity Envelope" chart (Figure 6-5) and if the intersection point is within the envelope, the loading is acceptable.



GULFSTREAM AMERICAN  
MODEL AA-5B TIGER

SECTION 6  
WEIGHT & BALANCE/  
EQUIPMENT LIST

SAMPLE LOADING PROBLEM	SAMPLE AIRPLANE			YOUR AIRPLANE		
	WEIGHT (LBS.)	ARM (IN.)	MOMENT (LB.-IN. /1000)	WEIGHT (LBS.)	ARM	MOMENT (IN. /1000)
*1. Licensed Empty Weight (Typical)	1373	82.18	112.83	_____	_____	_____
2. Oil (8 qts.) 1 qt. = 1.8 lbs.	15	32.0	.48	_____	32.0	_____
3. Fuel (in excess of unuseable)	306	94.8	29.01	_____	94.8	_____
4. Pilot and Co-Pilot	340	90.6	30.80	_____	90.6	_____
5. Rear Seat Passengers	340	126.0	42.84	_____	126.0	_____
*6. Baggage (in baggage compartment) Max. allowable 120 lbs.	26	151.0	3.93	_____	151.0	_____
7. Cargo Area Max. allowable 340 lbs.		116.4		_____	116.4	_____
8. Total Airplane Weight (loaded)	2400	91.62	219.89	_____		_____

NOTE: Change in moment from upright to fold-down position of rear seat is negligible.

\*Includes 74 pounds of optional equipment

\*\*Maximum allowable is 120 pounds if C.G. is within Center of Gravity Envelope. Refer to Cargo Loading and Weight and Balance Section for cargo loading instructions.

Figure 6-3. Sample Loading Problem

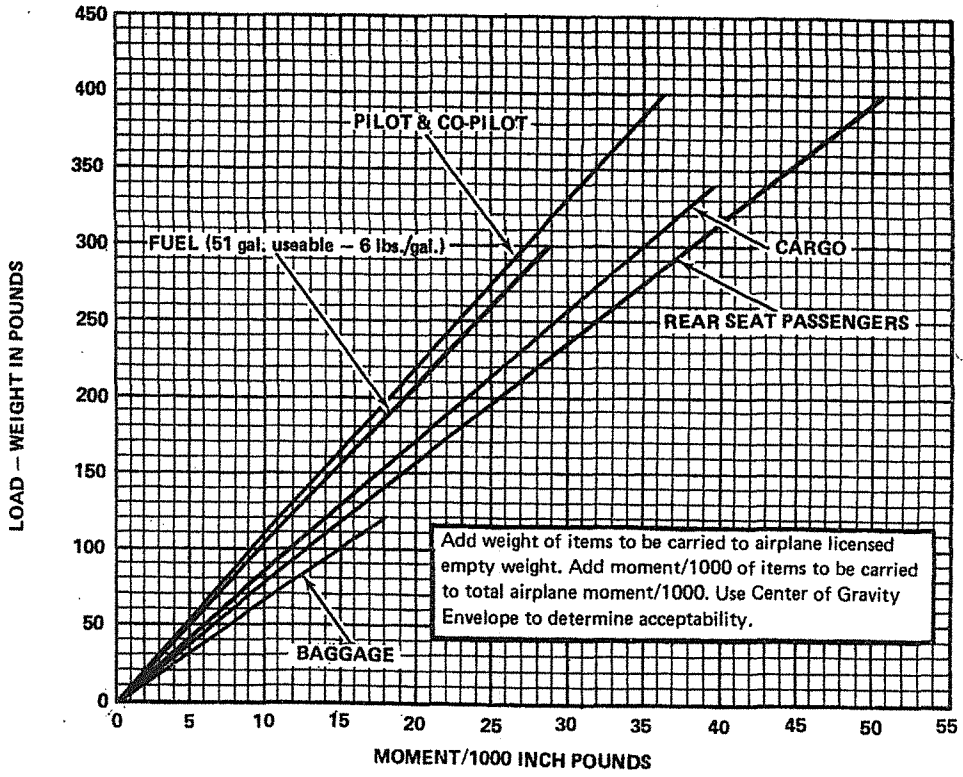

Figure 6-4. Loading Graph

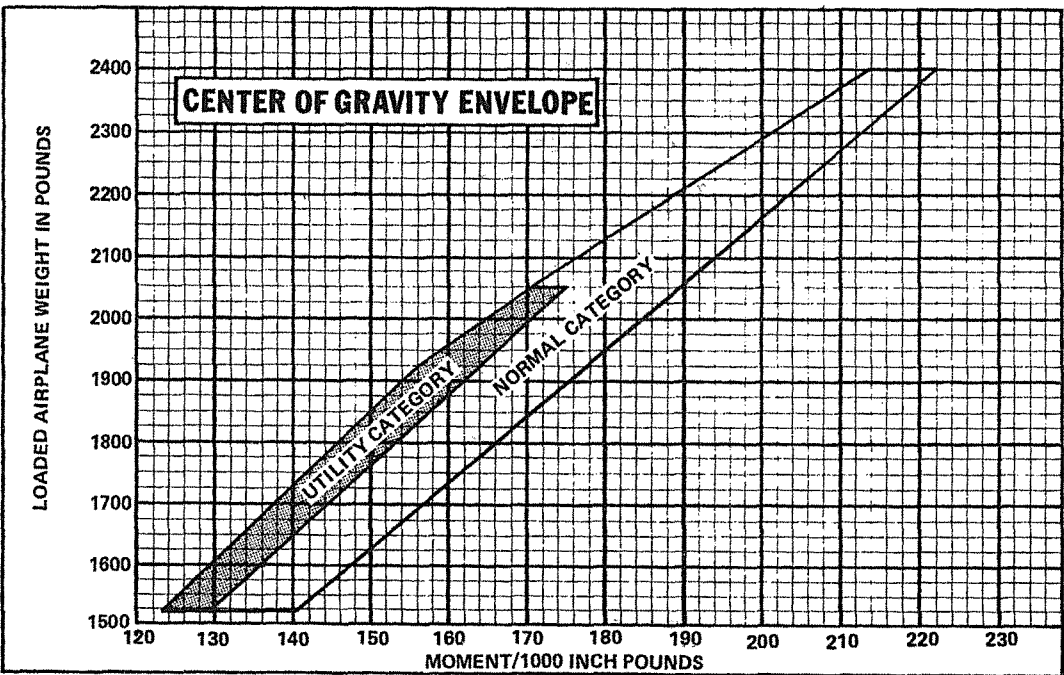

Figure 6-5. Center of Gravity Envelope

## CARGO LOADING

Prior to loading cargo, fold down rear seats as follows:

- (1) Release front seat latches and slide front seats forward.
- (2) Unsnap rear seat back cushions and remove cushions from seat back.
- (3) Fold seat bottom forward until it rests on floor.
- (4) Unlatch seat back latches and fold seat back forward until it rests on seat frame.

With rear seats folded down, in the cargo configuration, no passengers are allowed in the cargo area.

Place plywood or other suitable material under all high density cargoes to distribute the loads and prevent damage to the floors or supporting structures.

Figure 6-7 shows alternate seating or cargo arrangements, and provides the moment arms to various loading points within the airplane.

Figure 6-8 shows cargo belt arrangements for use in restraining cargo, in both the rear seat area and in the baggage compartment. The rear seat shoulder harness may be removed and used to secure items in the cargo area when the rear seats are folded down in the cargo configuration. These harnesses may be hooked to any of the exposed lap belt attachment points as shown in the cargo belt diagram. Internal cabin dimensions are presented in Figure 6-9.

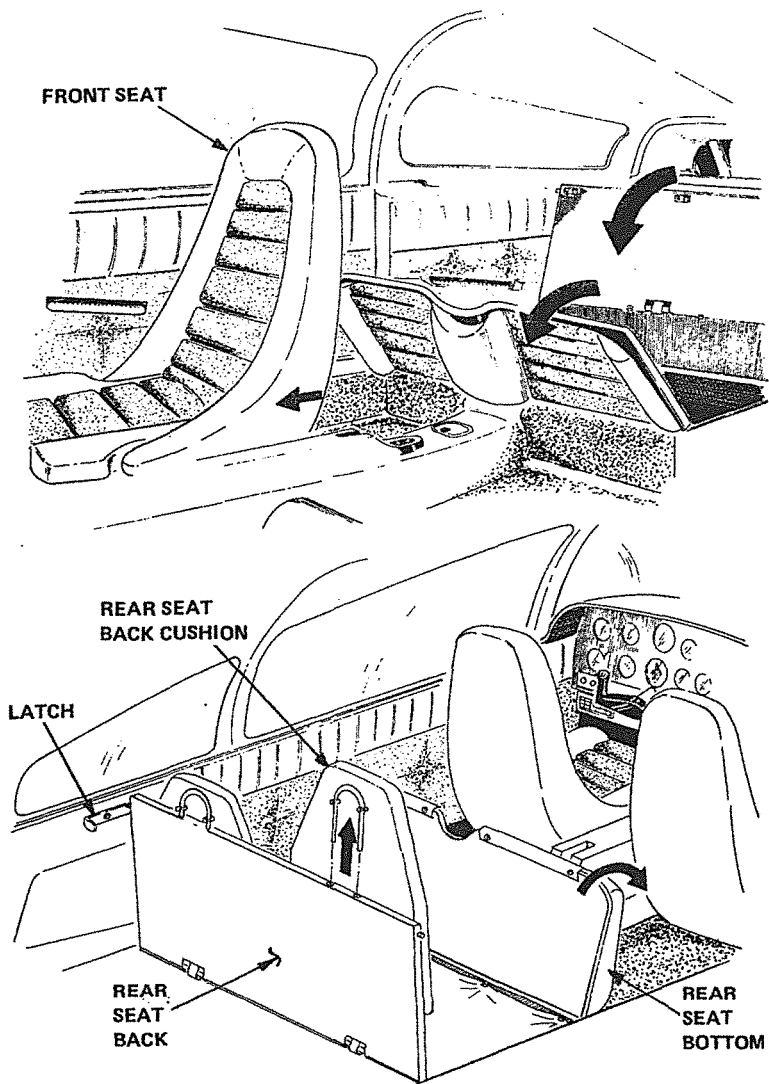
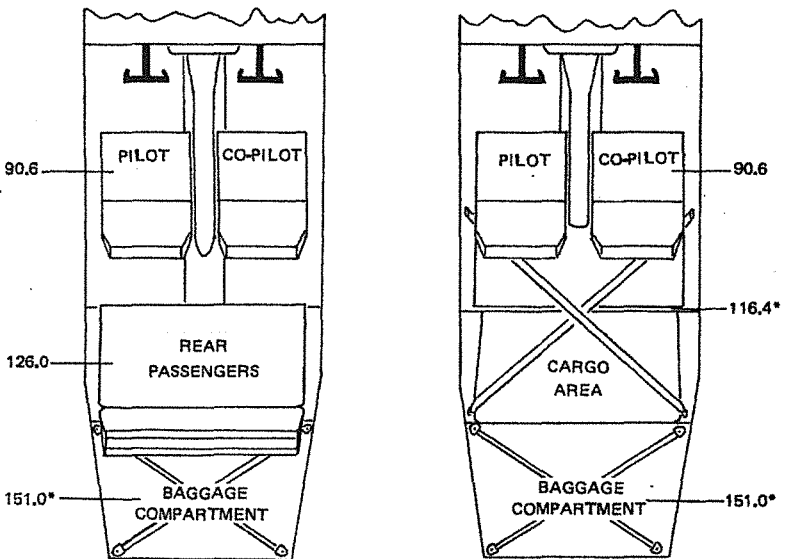

Figure 6-6. Rear Seat Stowage

SEATING-CARGO ARRANGEMENTS



\*Arms measure to center of area shown.

Figure 6-7. Seating - Cargo Arrangements

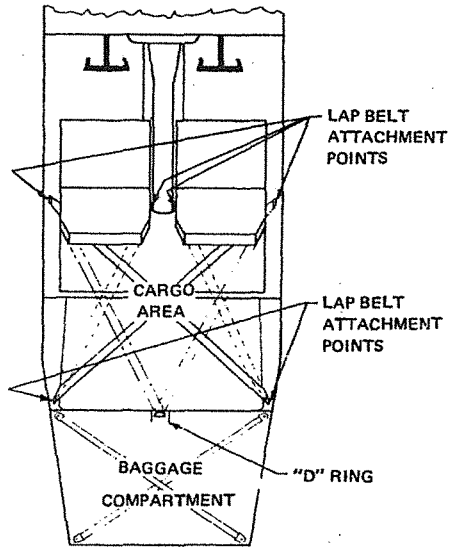

**CARGO BELT  
ALTERNATE ARRANGEMENTS**

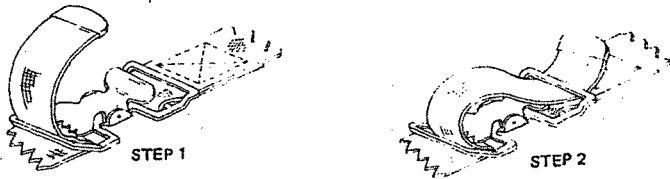

**BAGGAGE STRAP  
BUCKLING ILLUSTRATION**

Figure 6-8. Cargo Belt Arrangement

SECTION 6  
WEIGHT & BALANCE/  
EQUIPMENT LIST

GULFSTREAM AMERICAN,  
MODEL AA-5B TIGER

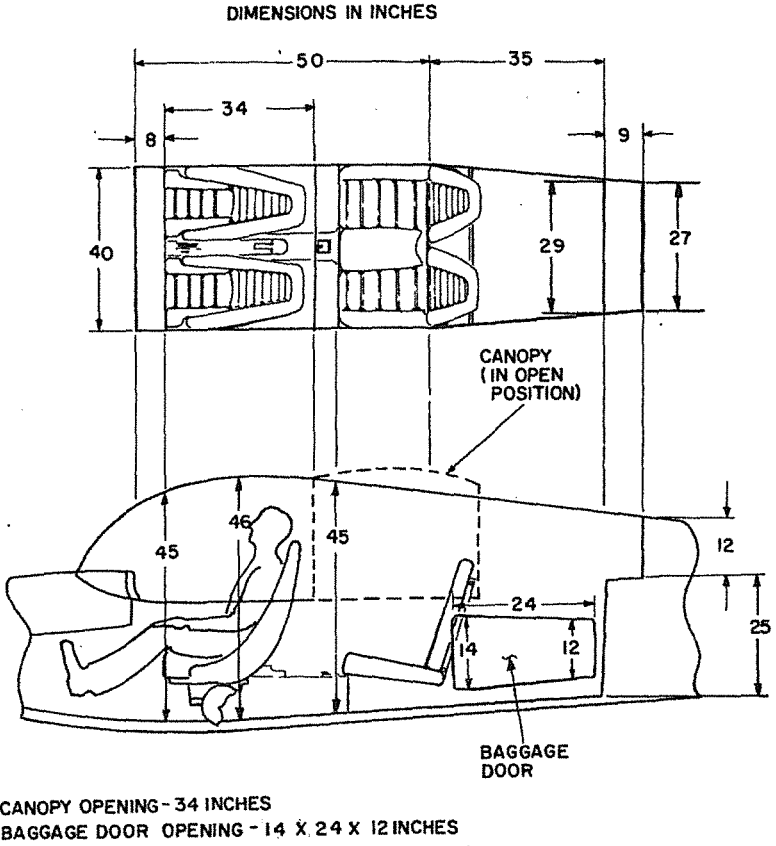

Figure 6-9. Internal Cabin Dimensions



### EQUIPMENT LIST

The following equipment list contains equipment normally available for the AA-5B airplane. A separate equipment list of items installed in your specific airplane is provided in your airplane file. The following list and the specific list for your airplane have a similar order of listing.

#### NOTE

If additional equipment is to be installed, it must be done in accordance with the reference drawing, accessory kit instructions, or a separate FAA approval.

Refer to applicable FAR's for a listing of specific equipment required for each mode of airplane operation.

Columns showing weight (in pounds) and arm (in inches) provide the weight and center of gravity location for the equipment.

#### NOTE

Unless otherwise indicated, true values (not net change values) for the weight and arm are shown. Positive arms are distances aft of the airplane datum; negative arms are distances forward of the datum.

SECTION 6  
WEIGHT & BALANCE/  
EQUIPMENT LIST

GULFSTREAM AMERICAN  
MODEL AA-5B TIGER

GULFSTREAM AMERICAN AA-5B TIGER

EQUIPMENT LIST

STATUS OF EQUIPMENT: X - Installed in Airplane  
O = Not Installed in Airplane

MODEL AA-5B SERIAL NO.	REG. NO.	DATE		
STATUS	ITEM	WEIGHT	ARM	
	<b>STANDARD EQUIPMENT</b>			
	Powerplant, Lycoming O-360-A4K	302.92	22.89	
	Alternator, 14V, 60A	---	---	
	Mechanical Fuel Pump	---	---	
	Quick Drain Oil Valve	---	---	
	Engine Primer	---	---	
	Muffler	14.82	23.30	
	Oil Cooler	3.16	36.00	
	Electric Fuel Pump	2.17	48.50	
	Fuel Selector Valve	.55	76.40	
	Fuel Tank Quick Drains	.20	93.50	
	Propeller, McCauley 1A170/FFA 7563	40.22	7.84	
	Spinner	2.67	4.32	
	Battery, 12V, 25 Ampere-hour	22.30	47.00	
	Voltage Regulator, 12V	.80	49.00	
	Standard Wiring System	1.36	41.30	
	Main Wheel, Tire & Brake (two 6.00 x 6, Type III)	36.75	100.15	
	Nose Gear Shock Absorber Installation	4.31	46.75	
	Nose Wheel, Tire & Tube (5.00 X 5, Cleveland)	8.70	36.10	
	Wheel Hub Covers	.07	71.33	
	Toe-Operated Brake	2.80	54.43	
	Parking Brake	.74	65.75	
	Electrical Flaps	9.56	124.40	
	Audible Stall Warning	.61	64.32	
	Aileron & Elevator Lock	.08	71.00	
	Pitot System (Std.)	1.78	122.65	
	Paint Scheme (Imron)	6.00	118.98	
	Step Strips	.05	89.50	
	Wing & Tail Tiedown Rings	.15	111.70	
	Canopy Latch	.10	86.50	
	Soundproofing	1.88	100.00	

Revised: February 15, 1979

GULFSTREAM AMERICAN  
MODEL AA-5B TIGER

SECTION 6  
WEIGHT & BALANCE/  
EQUIPMENT LIST

STATUS	ITEM	WEIGHT	ARM
<b>STANDARD EQUIPMENT (Continued)</b>			
	Headline, Fabric	.54	126.80
	Cabin Heating System	5.28	52.39
	Cabin Air Ventilators	2.28	66.03
	Center Console, Fore & Aft	2.40	95.60
	Instrument Panel Glare Shield	1.66	65.75
	Chart Holder	.08	70.00
	Baggage Tiedown Rings	.40	148.40
	Baggage Straps	.30	150.00
	Front Seats	24.50	92.50
	Seat Belts	2.50	119.65
	Shoulder Harness	4.32	132.83
	Armrests, Front & Rear (4)	.88	109.65
	Ashtrays (2)	.20	115.00
	Glove Compartment	.53	68.00
	Coat Hook	.02	105.40
	Fold Down Rear Seats	25.90	126.80
	Head Rests, Rear	1.00	136.88
	Airspeed Indicator	.50	68.50
	or True Airspeed Indicator	.50	68.50
	Altimeter (Std.)	1.12	68.00
	Instrument Cluster	.48	69.25
	Recording Tachometer	.62	69.00
	Fuse Holder & Spare Fuses	.01	69.00
	Vacuum Pump Pad	.01	37.00
	Quick Drain Oil Valve (Exchange)	— — —	— — —
	Magnetic Compass	.58	70.77
	Heated Pitot (Exchange)	.97	88.01
	Cabin Dome Light	.37	124.00
	Instrument Lights	.06	69.00
	Navigation Lights	.95	111.70
<b>OPTIONAL EQUIPMENT</b>			
	Altimeter, Sensitive (Feet & MB)	.88	68.00
	or Altimeter, Sensitive (Feet & In/Hg)	.88	68.00
	Encoding Altimeter AR-800 Narco	1.08	66.98
	or 8040B-15K Aero Mach	.88	66.86
	or 5035PZ-P25 United Inst.	.88	66.86
	or 5035P-P22 United Inst.	.88	66.86

SECTION 6  
WEIGHT & BALANCE/  
EQUIPMENT LIST

GULFSTREAM AMERICAN  
MODEL AA-5B TIGER

STATUS	ITEM	WEIGHT	ARM
<b>OPTIONAL EQUIPMENT (Continued)</b>			
	Gyro System (With Vacuum System)	10.55	59.69
	Turn Coordinator — Indicator	2.40	66.56
	Auxiliary Power Receptacle	1.50	44.50
	Cigarette Lighter	.25	75.00
	Clock (Electric)	.33	69.50
	Corrosion Proofing	3.38	110.00
	Fire Extinguisher	4.60	83.50
	Hour Meter	.40	69.25
	Tinted Windows	— —	— —
	Tow Bar	2.00	136.00
	Rear Seat Ventilation System	.33	119.00
	Front Seat Head Rests (2)	1.00	105.04
	Sunvisor (2)	.58	80.25
	Beacon, Omni Flash	1.04	231.60
	2-Light Strobe Installation	3.10	101.96
	Map Light	.25	79.40
	Wheel Fairings, Main Gear	16.36	99.76
	Wheel Fairing, Nose Gear	4.30	35.01
	Outside Step (L.H.)	2.52	127.68
	Outside Step (Both L.H. and R.H.)	5.05	127.68
	Alternate Static Source	.22	68.50
	Vertical Speed Indicator	.50	68.25
	Dual Controls	7.50	60.81
	Landing Light	1.17	17.35
	Storage Box Installation	— —	— —
	Glider Tow Hitch Installation	6.42	223.51
	Narco		
	AT-50A Transponder	4.89	62.14
	AT-150 Transponder	4.32	61.05
	Com 10/Nav 10 Com/Nav Transceiver	7.08	62.16
	Com 11A/Nav 11 Com/Nav Transceiver	7.78	62.38
	Com 11A/Nav 12/UGR 2A Com/Nav Transceiver	9.88	60.38
	Com 11A/Nav 14/UGR 2A/DGO 10 Com/Nav Transceiver	14.02	59.81
	Audio Switch Panel	1.20	70.00
	MBT-12 Marker Beacon (less light)	3.13	75.52
	Marker Beacon Light Assembly	.13	69.00

Revised: December 15, 1977

GULFSTREAM AMERICAN  
MODEL AA-5B TIGER

SECTION 6  
WEIGHT & BALANCE/  
EQUIPMENT LIST

STATUS	ITEM	WEIGHT	ARM
<b>OPTIONAL EQUIPMENT (Continued)</b>			
<b>Narco (Continued)</b>			
	Nav-121 Nav Receiver	3.72	60.42
	Nav-122 Nav Receiver	4.02	60.60
	Com-120 Transceiver	4.82	61.54
	CP-125 Audio Panel	1.69	67.55
	ELT-10 Emergency Locator Beacon	3.62	233.40
	ELT-10C Emergency Locator Beacon	2.70	233.40
	ADF-140 ADF Receiver	9.36	97.21
	DME-190 DME Indicator	6.60	66.41
<b>King</b>			
	KX-170B/201C Nav/Com Transceiver	10.33	65.02
	KX-170B/214C Nav/Com Transceiver	10.53	65.07
	KX-175/KI-210C Nav/Com Transceiver	10.33	65.02
	KX-175/KI-211C Nav/Com Transceiver	10.53	65.07
	KT-78 Transponder	3.21	65.24
	KR-85/KI-225 ADF Receiver	7.89	83.65
	KMA-20 Marker Beacon Receiver	2.38	68.27
	KT-76 Transponder	3.21	65.24
	KI-203/208 Vor Indicator	2.60	67.30
	KI-204/209 Vor/Glideslope Indicator	2.90	67.30
<b>Collins</b>			
	VHF-251	4.40	62.32
	VIR-351/IND-350/VHF-251	9.02	63.02
	VHF-251/VIR-351/IND-351/GLS-350	11.46	61.37
	RCR-650/IND-650/ANT-650	6.60	103.81
	TDR-950/Antenna	2.27	67.11
	AMR-350/Antenna	2.80	67.78
	Sidetone Intercom	.25	69.50
	Century I Autopilot	4.64	67.58
	Century II B Autopilot	10.85	61.92
	Microphone Installation	.50	91.80
	Turn and Bank Installation	1.94	68.00
	Pantionics H.F. DX10RA	14.00	120.57
	Bendix ADF	18.60	71.47

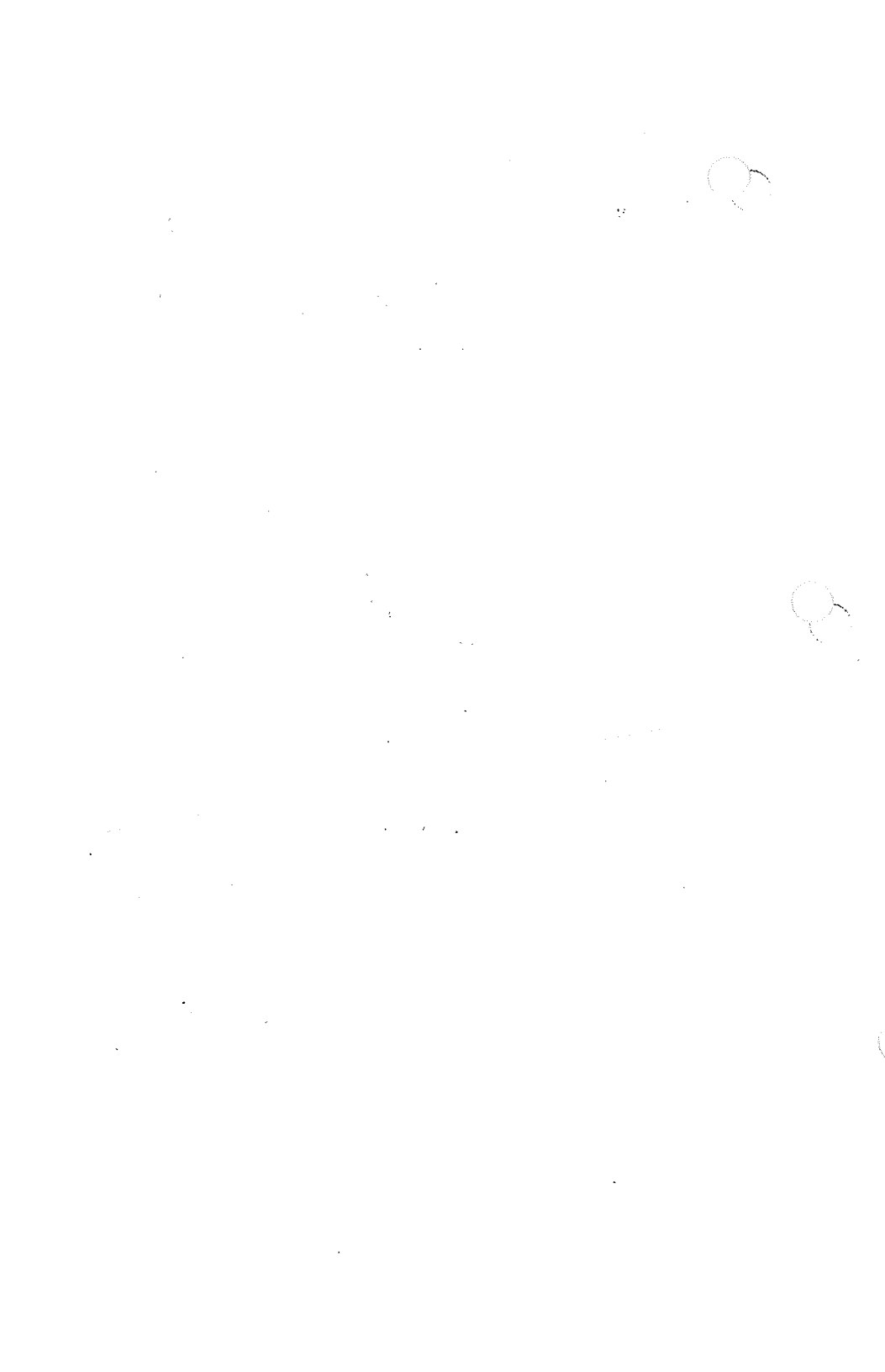

## SECTION 7 AIRPLANE & SYSTEMS DESCRIPTIONS

### TABLE OF CONTENTS

	Page
Introduction .....	7-3
Airframe .....	7-3
Flight Controls .....	7-4
Flaps .....	7-4
Instrument Panel .....	7-4
Console .....	7-4
Ground Control .....	7-6
Landing Gear System .....	7-6
Baggage Compartment .....	7-6
Seats and Belts .....	7-7
Cargo Configuration .....	7-8
Canopy .....	7-8
Control Locks .....	7-8
Engine .....	7-9
Engine Controls .....	7-9
Engine Instruments .....	7-9
New Engine Break-in and Operation .....	7-10
Engine Oil System .....	7-10
Ignition-Starter System .....	7-11
Air Induction System .....	7-12
Exhaust System .....	7-12
Carburetor and Priming System .....	7-12
Cooling System .....	7-12
Propeller .....	7-13
Fuel System .....	7-13
Brakes .....	7-13

SECTION 7  
AIRPLANE & SYSTEMS  
DESCRIPTIONS

GULFSTREAM AMERICAN  
MODEL AA-5B TIGER

TABLE OF CONTENTS (Continued)

	Page
Electrical System .....	7-15
Master Switch .....	7-15
Ground Service Plug Receptacle .....	7-17
Lighting Systems .....	7-17
Exterior Lighting .....	7-17
Interior Lighting .....	7-18
Cabin Dome Light .....	7-18
Instrument Panel Lights .....	7-18
Map Light .....	7-18
Cabin Heating, Ventilating and Defrosting System .....	7-18
Heating — Defrosting System .....	7-18
Ventilation .....	7-19
Pitot-Static System and Instruments .....	7-21
Airspeed Indicator .....	7-21
Vertical Speed (Rate of Climb) Indicator .....	7-22
Altimeter .....	7-22
Vacuum System and Instruments .....	7-22
Attitude Indicator .....	7-22
Directional Indicator .....	7-24
Suction Gauge .....	7-24
Stall Warning System .....	7-24
Avionics Support Equipment .....	7-24

Issued: September 30, 1976



## INTRODUCTION

This section describes the operation of the airplane and its various systems. Since some of the equipment described herein is optional it may not be installed on your particular airplane. Refer to Section 9, Supplements, for details of other optional equipment and systems.

## AIRFRAME

The AA-5B is an all-metal, four-place, low-wing, single-engine airplane, equipped with tricycle landing gear, and designed for general utility uses.

The cabin portion of the fuselage is constructed of bonded metal honeycomb panels assembled to form a rigid structure. Flat bonded metal floor panels extend the length of the cabin area and baggage compartment. The aft fuselage is constructed of sheet aluminum panels bonded to form a semi-monocoque structure.

Passenger and crew entrance into the cabin area is provided by a sliding canopy, which may be closed and latched, or opened partially during flight. In addition to providing convenient access to the cabin, the canopy arrangement also provides excellent visibility for the pilot and passengers. Access to the baggage compartment (behind the rear seats) is provided by a baggage door on the left side of the fuselage.

A tubular spar carry-through, located beneath the pilot's seat, provides the attachment points for the wings and main landing gear. This arrangement provides the AA-5B airplane with an extremely strong center section.

The full cantilever, modified laminar flow wings contain integral fuel tanks. They are constructed of stamped metal ribs adhesive bonded to the metal wing skin, and supported by a tubular spar extending the length of the wing. This type of structure provides an exceptionally strong wing with smooth, unmarred surface. Clean aerodynamic surfaces contribute significantly to the excellent performance of the AA-5B airplane. The integral fuel tanks are located on the inboard ends of the wings to provide a centralized source of fuel to the engine.

The AA-5B empennage consists of a conventional vertical stabilizer/rudder, and a horizontal stabilizer incorporating a conventional elevator with an anti-servo tab. Both horizontal and vertical stabilizers are of conventional rib-stiffened structure with the ribs bonded to a metal skin. The elevator is of the anti-servo type, providing a very responsive control with relatively light control pressures required.

## FLIGHT CONTROLS

The control surfaces are operated by a combination of torque tubes and conventional cable systems. The elevator anti-servo trim tabs are located on the elevator trailing edges and are actuated manually by the trim wheel located on the center console. Ground adjustable tabs on the rudder and ailerons provide a simple method of adjusting directional and lateral trim.

## FLAPS

Electrically operated flaps provide a full range of settings by means of a spring loaded, three position switch. The flap actuator switch is held down until the flap position indicator shows the desired flap angle; when released, it returns to neutral, and flap travel stops.

### CAUTION

ABRUPTLY RELEASING THE  
SWITCH MAY CAUSE IT TO SNAP  
THROUGH THE NEUTRAL DETENT,  
INTO THE RETRACT POSITION.

## INSTRUMENT PANEL

The instrument panel (Figure 7-1) employs a unique "eyebrow" design which shields the windshield from panel reflections during night flights. The eyebrow also houses the instrument panel lights which are controlled by a switch rheostat (OFF and INTENSITY) located just above the throttle. Other panel switches are the rocker type.

## CONSOLE

The center console serves as a front seat divider and provides a storage clip for the microphone. It also houses the microphone jack, the flap switch, flap position indicator, trim wheel, trim position indicator, ash tray, cigarette lighter, fuel selector valve, and fuel gauges.

**GULFSTREAM AMERICAN  
MODEL AA-5B TIGER**

**SECTION 7  
AIRPLANE & SYSTEMS  
DESCRIPTIONS**

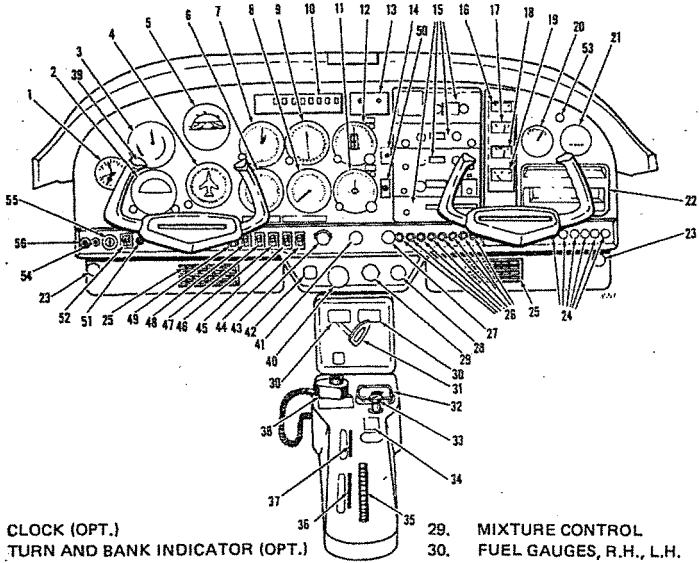

- |                                    |                                   |
|------------------------------------|-----------------------------------|
| 1. CLOCK (OPT.)                    | 29. MIXTURE CONTROL               |
| 2. TURN AND BANK INDICATOR (OPT.)  | 30. FUEL GAUGES, R.H., L.H.       |
| 3. AIRSPEED INDICATOR              | 31. FUEL SELECTOR                 |
| 4. DIRECTIONAL GYRO (OPT.)         | 32. ASH TRAY                      |
| 5. HORIZON GYRO (OPT.)             | 33. CIGARETTE LIGHTER (OPT.)      |
| 6. VERTICAL SPEED INDICATOR (OPT.) | 34. FLAP SWITCH                   |
| 7. ALTIMETER                       | 35. TRIM TAB CONTROL              |
| 8. TACHOMETER                      | 36. TRIM POSITION INDICATOR       |
| 9. ADF INDICATOR (OPT.)            | 37. FLAP POSITION INDICATOR       |
| 10. RADIO SELECTOR SWITCH (OPT.)   | 38. MICROPHONE                    |
| 11. OMNI HEAD (OPT.)               | 39. MICROPHONE SWITCH             |
| 12. OMNI HEAD (OPT.)               | 40. THROTTLE                      |
| 13. AUTOPILOT CONTROL (OPT.)       | 41. CABIN HEAT CONTROL            |
| 14. AMPLIFIER SWITCH (OPT.)        | 42. CARBURETOR HEAT CONTROL       |
| 15. COMM/NAV EQUIPMENT (OPT.)      | 43. INSTRUMENT LIGHTS CONTROL     |
| 16. AMMETER                        | 44. LANDING LIGHT SWITCH          |
| 17. OIL TEMPERATURE GAUGE          | 45. FLASHING BEACON SWITCH (OPT.) |
| 18. OIL PRESSURE GAUGE             | 46. STROBE LIGHT SWITCH (OPT.)    |
| 19. FUEL PRESSURE GAUGE            | 47. PITOT HEAT SWITCH (OPT.)      |
| 20. SUCTION GAUGE                  | 48. NAVIGATION LIGHTS SWITCH      |
| 21. HOURMETER (OPT.)               | 49. FUEL PUMP SWITCH              |
| 22. GLOVE COMPARTMENT              | 50. ELT SWITCH (OPT.)             |
| 23. VENT CONTROLS, R.H., L.H.      | 51. STARTER SWITCH                |
| 24. FUSES                          | 52. MASTER SWITCH                 |
| 25. VENT LOUVERS, R.H., L.H.       | 53. ALTERNATOR WARNING LIGHT      |
| 26. CIRCUIT-BREAKERS               | 54. EARPHONE JACK                 |
| 27. PARKING BRAKE                  | 55. IGNITION SWITCH               |
| 28. PRIMER                         | 56. MICROPHONE JACK               |

**Figure 7-1. Instrument Panel**

Revised: December 15, 1977

## GROUND CONTROL

Since the AA-5B nose wheel is free-castering, ground control during taxiing is accomplished by use of differential braking. Application of left brake causes the airplane to turn left and right brake causes a right turn. Due to the fact that the nose wheel swivels approximately 90° either side of center, the AA-5B is capable of turning in a very tight radius (less than 20 feet).

During ground handling the airplane should be pushed and controlled by use of the tow bar provided with the airplane.

### CAUTION

USING THE PROPELLER FOR GROUND HANDLING COULD RESULT IN SERIOUS DAMAGE, ESPECIALLY IF PRESSURE IS EXERTED ON THE OUTER ENDS. DO NOT ATTEMPT TO PUSH THE AIRPLANE BACKWARD WITHOUT THE AID OF A TOW BAR. THIS ACTION COULD RESULT IN THE NOSE WHEEL PIVOTING ABRUPTLY AND DAMAGING THE NOSE WHEEL STOPS.

## LANDING GEAR SYSTEM

The FACE SAVER<sup>®</sup> main landing gear struts are of tough, laminated fiberglass to achieve outstanding shock absorption and good ground stability. The nose gear is free-castering to approximately 90° on either side of the centerline, which gives good maneuverability on the ground.

## BAGGAGE COMPARTMENT

The baggage compartment occupies the area extending from the back of the rear seats to the aft cabin bulkhead. This bulkhead also contains a hat shelf. Access to the baggage compartment is gained through a lockable baggage door on the left side of the airplane, or from within the airplane cabin. Two tiedown straps extend diagonally across the baggage compartment, for use in securing luggage. For loading information regarding the baggage compartment see Section 6. When loading the airplane, children or pets should not be placed or permitted in the baggage compartment, and any material that might be hazardous to the airplane or its occupants should not be taken aboard. The baggage door can be opened from

inside the airplane by actuating the sliding latch attached to inside the door. For baggage area and door dimensions refer to Section 6.

### SEATS AND BELTS

Contoured front seats are individually adjustable fore and aft using the adjustment levers located on the outboard side of each seat. The front seat backs fold forward for easy access to the rear seat.

#### CAUTION

THE SEAT RELEASE-ADJUSTMENT HANDLES MOVE IN A HORIZONTAL DIRECTION. IF FORCE IS APPLIED TO THE HANDLES IN THE VERTICAL DIRECTION THE SEAT ADJUSTMENT MECHANISM MAY BE DAMAGED.

#### NOTE

SHOULDER BELTS ARE PROVIDED FOR YOUR SAFETY. BE SURE TO USE THEM. THE SHOULDER BELT FASTENS TO THE END OF THE OUTBOARD LAP BELT, ALLOWING BOTH BELTS TO BE FASTENED OR REMOVED IN ONE OPERATION. LAP AND SHOULDER BELTS MAY BE NEATLY STOWED BY HANGING THEM ON THE SIDE PANEL SUPPORTS PROVIDED.

LAP BELTS SHOULD BE ADJUSTED TO LIE LOW ON THE HIPS, WITHOUT ANY SLACK. SHOULDER BELTS SHOULD LIE OVER THE OUTER SHOULDER AND ACROSS THE CHEST, WITH JUST ENOUGH SLACK TO REACH ALL CONTROLS COMFORTABLY.

## CARGO CONFIGURATION

The rear seat and seat back may be folded forward to provide a large cargo area. Both front seats should be in the full forward position to swing the rear seat bottom up and fold it forward.

### NOTE

When the rear seat bottom is folded forward, the rear seat back must be folded down.

The rear seat shoulder harness may be removed and used to secure items in the cargo area when the rear seats are folded down in the cargo configuration. These harnesses may be hooked to any of the exposed lap belt attachment points as shown in the cargo belt diagram in Section 6.

## CANOPY

Entry into and exit from the airplane is accomplished by releasing the canopy latch and sliding the canopy aft. The canopy latch is actuated by an external handle on the front center of the canopy and an internal handle located inside the canopy at its front center. The external handle opens the latch by counterclockwise rotation and the internal handle opens the latch by rearward movement. A lock to the left of the external handle provides a means of externally locking the canopy. The canopy is designed to open a longitudinal distance of 34 inches and is limited by stops. See Section 6 for canopy entrance dimensions. The canopy may be partially opened in flight to provide ventilation or better visibility. However, **THE CANOPY MUST BE COMPLETELY CLOSED AND LOCKED WHEN FLYING AT AIRSPEEDS IN EXCESS OF 113 KCAS (130 MPH)**. The cabin windows aft of the canopy are of the fixed type and cannot be opened.

## CONTROL LOCKS

A control lock is provided to lock the elevator control surfaces in the down position and the ailerons at neutral, to prevent damage to these systems by wind buffeting while the airplane is parked. Having the controls locked in the down position prevents takeoff with the lock installed. The lock consists of a shaped steel rod with a red metal flag attached to it. The flag is labeled **CONTROL LOCK, REMOVE BEFORE STARTING ENGINE**. To install the control lock, align the hole on the top of the pilot's control wheel shaft with the hole in the top of the shaft collar on the instrument panel and insert the rod into the aligned holes. Proper installation of the lock will place the red flag over the ignition switch. The control lock and any other type of locking device should be removed prior to starting the engine.

Issued: September 30, 1976

## ENGINE

The airplane is powered by a horizontally-opposed, four-cylinder overhead-valve, air-cooled, carburetor equipped engine with a wet sump oil system. The engine is a Lycoming Model O-360-A4K and is rated at 180 horsepower at 2700 RPM. Major accessories mounted on the engine include a direct-drive starter and belt-driven alternator on the front of the engine, dual magnetos, an engine-driven fuel pump, a full flow oil filter, and a vacuum pump on the rear of the engine.

## ENGINE CONTROLS

Engine power is controlled by a throttle located on the lower center portion of the instrument panel. The throttle operates in a conventional manner; in the full forward position, the throttle is open, and in the full aft position, it is closed. A friction lock, which is a round knurled disk, is located at the base of the throttle and is operated by rotating the lock clockwise to increase friction or counterclockwise to decrease it.

The mixture control, mounted to the right of the throttle, is a red knob with raised points around the circumference. The rich position is full forward, and full aft is the idle cut-off position. To adjust the mixture, move the control forward or aft.

The carburetor heat control is the square knob mounted to the left of the throttle. When this control is pushed in, ambient air is routed through the air filter and into the carburetor. When the control is pulled out, the ambient air is routed through a heater muff surrounding the muffler; where it is heated prior to induction through the air filter into the carburetor.

## ENGINE INSTRUMENTS

Engine operation is monitored by the following instruments: oil pressure gauge, oil temperature gauge, tachometer and fuel pressure gauge.

The oil pressure gauge, which is mounted in the instrument cluster on the right of the instrument panel, is operated directly by oil pressure from the engine. Gauge markings indicate a minimum idling pressure of 25 PSI (red line), a normal operating range of 60 to 90 PSI (green arc) and a maximum allowable pressure of 100 PSI (red line).

The oil temperature gauge, which is also mounted in the instrument cluster, is operated by an electrical resistance type temperature sensor powered by the airplane electrical system. Oil temperature limitations are the normal operating range (green arc) which is 75°F (24°C) to 245°F (118°). Maximum allowable (red line) is 245°F (118°C).

The engine-driven mechanical tachometer is located near the lower center portion of the instrument panel. The instrument is marked in increments of 100 RPM and indicates engine speed. An hour meter below the center of the tachometer dial records elapsed engine time in hour, tenths, and hundredths. Instrument markings include a normal operating range of 2100 to 2700 RPM. Maximum (red line) at any altitude is 2700 RPM. A yellow arc from 1850 to 2250 RPM is provided to caution the pilot against continuous engine operation in this range during descent.

A fuel pressure gauge, on the instrument cluster, indicates fuel pressure to the carburetor in pounds per square inch. The gauge is operated by fuel pressure. Gauge markings are in 0.5, 5 and 8 PSI with a red line at 0.5 PSI and 8 PSI. A green arc extends from 0.5 PSI to 8 PSI to indicate the normal operating range.

#### **NEW ENGINE BREAK-IN AND OPERATION**

The engine underwent a run-in at the factory and is ready for the full range of use. It is, however, recommended that power be maintained at 75% or more until a total of 50 hours has accumulated. This will ensure proper seating of the rings.

The airplane is delivered from the factory with corrosion preventive oil in the engine. If, during the first 25 hours, oil must be added, use only aviation grade straight mineral oil conforming to Specification No. MIL-L-6082 (Figure 1-2).

#### **ENGINE OIL SYSTEM**

Oil for engine lubrication is supplied from a sump on the bottom of the engine. The capacity of the engine sump is eight quarts. Oil is drawn from the sump through an oil suction strainer into the engine-driven oil pump. From the pump, oil is routed to a bypass valve. If the oil is cold, the bypass valve allows the oil to go directly from the pump to the oil filter. If the oil is hot, the bypass valve routes the oil out of the accessory housing and into a flexible hose leading to the oil cooler on the left rear of the engine. Pressure oil from the cooler returns to the accessory housing where it enters the oil filter. The filtered oil then enters a pressure relief valve which regulates engine oil pressure by allowing excessive oil to return to the pump, while the balance of the oil is circulated to various engine parts for lubrication. Residual oil is returned to the sump by gravity flow.



An oil filler cap/oil dipstick is located at the rear of the engine on the right side. The filler cap/dipstick is accessible through the engine cowling (or through the oil filler access door). The engine should not be operated on less than six quarts of oil. To minimize loss of oil through the breather, fill to seven quarts for normal flights of less than three hours. For extended flight, fill to eight quarts (dipstick indication only). For engine oil grade and specifications, refer to Section 8 of this handbook.

An oil quick-drain valve is available to replace the drain plug in the oil sump drain port, and provides quicker, cleaner draining of the engine oil. To drain the oil with this valve installed, slip a hose over the end of the valve and push upward on the end of the valve until it snaps into the open position. Spring clips will hold the valve open. After draining, use a suitable tool to snap the valve into the extended (closed) position and remove the drain hose.

#### IGNITION-STARTER SYSTEM

Engine ignition is provided by an engine-driven dual magneto, and two spark plugs for each cylinder. The right magneto fires the lower right and upper left spark plugs, and the left magneto fires the lower left and upper right spark plugs. Normal operation is conducted with both magnetos due to the more complete burning of the fuel-air mixture with dual ignition.

Ignition is controlled by a rotary, key-actuated switch located near the bottom left of the instrument panel. The switch is labeled clockwise; OFF, R, L, BOTH. The engine should be operated with the switch in the BOTH position except for starting and magneto checks. When the engine is started the ignition switch should be placed in the L (left magneto only) position to minimize the possibility of starter damage should there be an engine "kickback". Once the engine is started the switch should be set to BOTH, except for magneto checks, since extended engine operation on one magneto could result in spark plug fouling.

#### CAUTION

PRESSING THE STARTER BUTTON  
WITH THE ENGINE RUNNING CAN  
RESULT IN STARTER OR ENGINE  
DAMAGE.

The starter button is located immediately to the left of the ignition switch. When the master switch is on, the starter button actuates the starter as long as the button is depressed. Upon engine startup, the button should be released immediately.

## **AIR INDUCTION SYSTEM**

The engine air induction system receives ram air through the engine air intake in the right side of the cowling nose cap. The ram air passes through a duct to the air filter located in the carburetor air box. This filter is a paper type filter which removes dust and foreign matter from the air prior to its entry into the carburetor.

When carburetor heat is being applied, a flapper valve in the intake to the air filter is closed off and the carburetor then draws its input from a shroud around the engine exhaust muffler. See Section 8 for air filter servicing requirements.

## **EXHAUST SYSTEM**

Exhaust gas from each cylinder passes through riser assemblies to a muffler and tailpipe. The muffler is constructed with a shroud around the outside which forms heating chambers for cabin heat air, and carburetor air heat.

## **CARBURETOR AND PRIMING SYSTEM**

The engine is equipped with a horizontal, float-type, fixed jet carburetor mounted on the rear of the engine. The carburetor is equipped with an enclosed accelerator pump, simplified fuel passages to prevent vapor locking, an idle cut-off mechanism, and a manual mixture control. Fuel is delivered to the carburetor by an engine-driven fuel pump, or an auxiliary electric fuel pump from the fuel system. In the carburetor, fuel is atomized, proportionally mixed with intake air, and delivered to the cylinders through intake manifold tubes. The proportion of atomized fuel to air is controlled, within limits, by the mixture control on the instrument panel.

For easy starting in cold weather, the engine is equipped with a manual primer. The primer is actually a small pump which draws fuel from the fuel strainer when the plunger is pulled out, and injects it into the cylinder intake ports when the plunger is pushed back in. The plunger knob, on the instrument panel, is equipped with a lock, and, after being pushed full in, must be rotated either left or right until the knob cannot be pulled out.

## **COOLING SYSTEM**

Ram air for engine cooling enters through two intake openings in the cowling nose cap. The cooling air is directed around the cylinders and other engine areas by baffling, and is then exhausted through openings in the bottom of the cowling.

Revised: July 15, 1978

## PROPELLER

The AA-5B is equipped with an all-metal, two-bladed, fixed-pitch propeller, McCauley Corp. No. 1A170/FFA 7563, 1A170/KFA 7563 or 1A170E/KFA 7563.

## FUEL SYSTEM

The AA-5B's fuel system (Figure 7-2) consists of two tanks with a total capacity of 52.6 gallons, of which 51 gallons are usable, two sump tanks (one in each wing root fairing), independent fuel gauges and a fuel selector valve. The fuel tanks are vented and equipped with two main fuel lines in each tank, located to assure fuel supply in all normal flight attitudes. The flush mounted fuel tank vents are located in the bottom of the outboard wing panels, just forward and inboard from the wing tie downs. A mechanical fuel pump, mounted on the engine, transfers fuel from the tanks to the carburetor.

An auxiliary electric fuel pump supplements the engine-driven pump. Fuel pressure is indicated on a gauge in the engine instrument cluster, located to the right of the radio section of the instrument panel. The electric pump should be turned on if the engine-driven pump fails as noted by a loss of fuel pressure. The electric fuel pump can also be used to provide fuel pressure redundancy during low altitude operation, such as during takeoff and landing.

There are four fuel drains on the airplane. One is located in each fuel tank and one in each sump tank. They can be reached under the front side of the wing at the wing root on each side of the airplane. A drain cup is provided (in the glove box) for draining fuel which should be inspected for water or sediment contamination, prior to each flight.

## BRAKES

The brakes are toe-operated, single-disc hydraulic systems with integral parking brakes. The brakes provide all steering control while taxiing. At speeds above 13 KIAS (15 MPH) to 17 KIAS (20 MPH), the rudder becomes fully effective and brake steering is not necessary. The parking brake is set by pressing the toe brakes; pulling the parking brake knob; then releasing brake pedal pressure. To release, push the parking brake knob in, then press the toe-brakes firmly. Parking brakes are operated from the left side only.

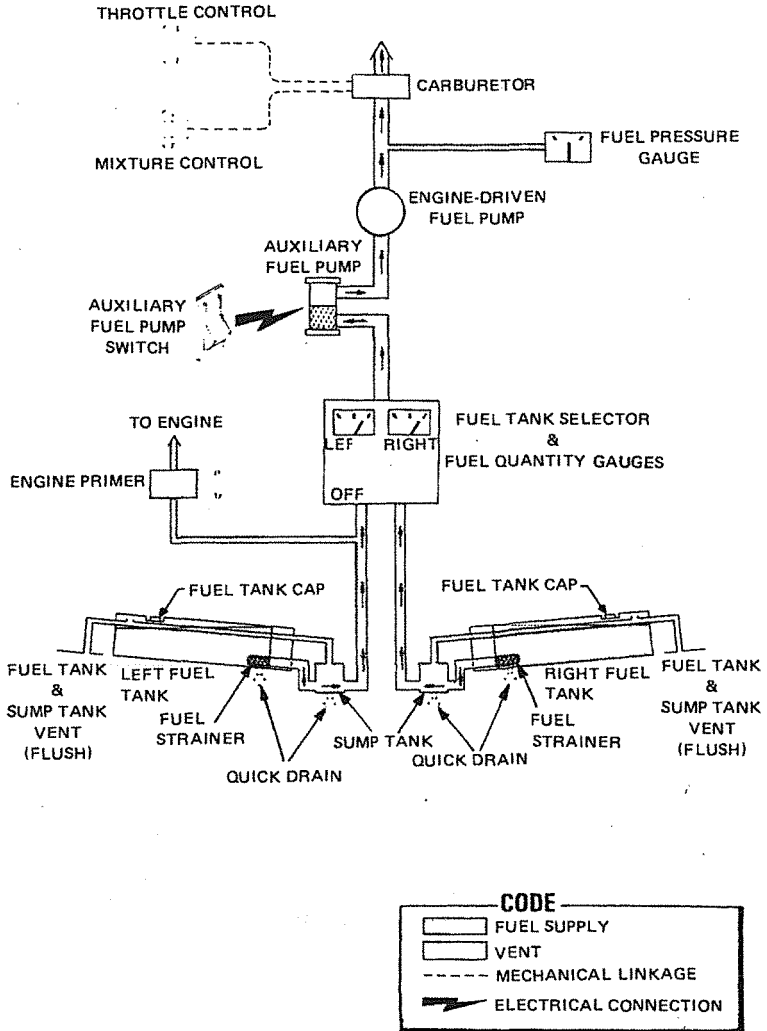

Figure 7-2 Fuel System

Revised: July 15, 1978

## ELECTRICAL SYSTEM

The electrical system (Figure 7-3) uses a 14-volt, 60-amp alternator with internal power diodes which delivers DC power directly to the main bus through a 60-amp circuit breaker. An external voltage regulator controls the alternator output voltage and automatically adjusts the battery charging rate to maintain proper charge. The electrical system ammeter is located in the engine instrument cluster and indicates current charge (+) and discharge (—) of the battery.

The master switch is a split rocker type which serves two functions. One side (master) energizes the battery circuit for engine starting and operating electrical systems with the engine OFF. The other side (alt) energizes the alternator field circuit which produces the electrical field in the alternator. With the electrical field energized, the alternator supplies all of the required current for the system loads through the bus bar.

In the event of alternator failure, as indicated by a battery discharge indication on the ammeter, the alternator side of the master switch can be turned OFF and the airplane systems then operated on the existing battery voltage. To conserve the battery voltage, only the necessary electrical systems should be ON when operating from the battery.

The alternator circuits are protected by a 60-amp alternator circuit breaker and a 5-amp alternator field circuit breaker. Should either of these breakers open due to excessive current in the system, they should be reset after waiting at least 15 seconds. If either breaker will not reset, the alternator side of the master switch should be turned OFF and the airplane systems then operated on existing battery voltage.

Fuses and circuit breakers for the electrical systems are located on the lower right side of the instrument panel, and spare fuses are mounted in the right side of the glove compartment. Electrical switches for exterior lighting and accessories are located at the right of the pilot's control column.

The engine's dual-magneto ignition system is completely independent of the airplane electrical system, and will continue to operate in the event of an electrical system failure.

## MASTER SWITCH

The master switch is a split-rocker type switch labeled MASTER, and is ON in the up position and OFF in the down position. The right half of the switch, labeled BAT, controls all electrical power to the airplane. The left half, labeled ALT, controls the alternator.

SECTION 7  
 AIRPLANE & SYSTEMS  
 DESCRIPTIONS

GRUMMAN AMERICAN  
 MODEL AA-5B TIGER

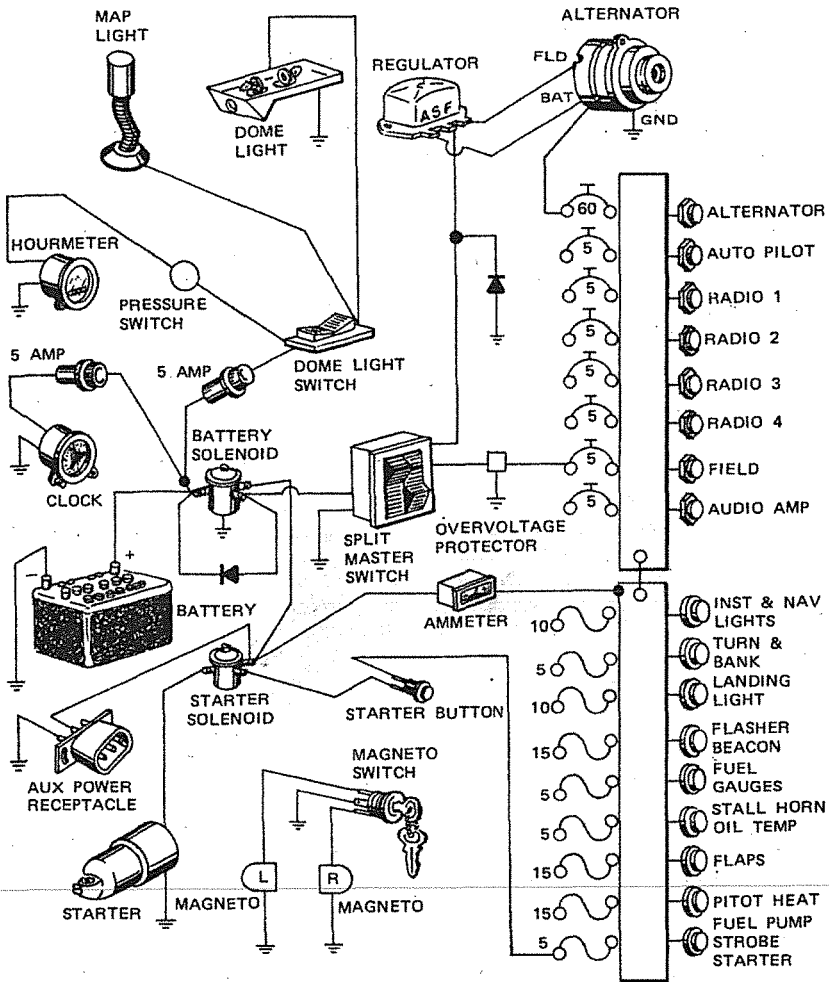
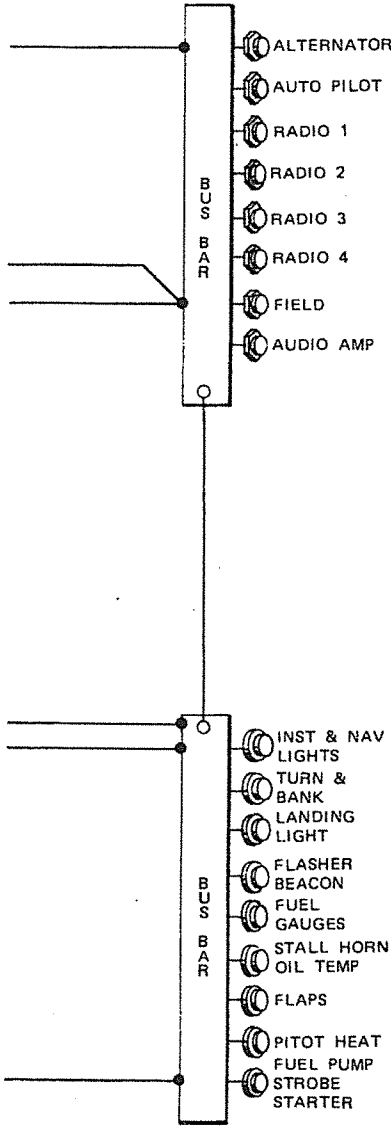

Figure 7-3, Electrical System

GULFSTREAM AMERICAN  
MODEL AA-5B TIGER

SECTION 7  
AIRPLANE & SYSTEMS  
DESCRIPTIONS



NOTES:

⚠ 1978 Model and subsequent.

CODE		
	CIRCUIT BREAKER (PUSH-TO-RESET)	
		FUSE (IN LINE)
		DIODE

Figure 7-3 Electrical System (Sheet 2 of 2)

Revised: December 15, 1977

7-16a/(7-16b blank)





Normally, both sides of the master switch should be used simultaneously; however, the BAT side of the switch could be turned ON separately to check equipment while on the ground. The ALT side of the switch, when placed in the OFF position, removes the alternator from the electrical system. With this switch in the OFF position, the entire electrical load is placed on the battery.

#### **GROUND SERVICE PLUG RECEPTACLE**

A ground service plug receptacle may be installed to permit the use of an external power source for cold weather starting and during lengthy maintenance work on the airplane electrical system. The receptacle is located under a cover plate, on the cowling on the right side of the fuselage.

#### **NOTE**

When external power is used, voltage transients may be introduced into the electrical system. Ensure that all radios and other electronic equipment remain deenergized when external power is being applied to the airplane.

Just before connecting an external power source (generator type or battery cart), the master switch should be turned off.

#### **LIGHTING SYSTEMS**

##### **EXTERIOR LIGHTING**

Conventional navigation lights are located on the wing tips and tail cone. A landing light is installed in the nose cap, and a flashing beacon is mounted on top of the rudder. In addition, strobe lights are available for installation on each wing tip. All external lights are controlled by rocker type switches on the bottom left of the instrument panel. The switches are ON in the up position and OFF in the down position.

**SECTION 7  
AIRPLANE & SYSTEMS  
DESCRIPTIONS**

**GULFSTREAM AMERICAN  
MODEL AA-5B TIGER**

The flashing beacon should not be used when flying through clouds or overcast; the flashing light reflected from water droplets or particles in the atmosphere, particularly at night, can produce vertigo and loss of orientation.

The two strobe lights will enhance anti-collision protection. However, the lights must be turned off when taxiing in the vicinity of other airplanes, or during night flight through clouds, fog or haze.

**INTERIOR LIGHTING**

**CABIN DOME LIGHT**

A cabin dome light is provided for illuminating the seating area and baggage compartment. It is controlled by a 3-position rocker switch which is located on the fuselage side panel to the left of the pilot's control wheel. This location provides easy operation by the pilot when in flight, and also convenient access from the outside when entering the airplane at night. The switch forward position illuminates the front cabin area, the center position is off, and the aft position illuminates both the front and rear cabin areas. It is energized directly from the battery regardless of the master switch position.

**INSTRUMENT PANEL LIGHTS**

The instrument panel lights are controlled by a rheostat mounted directly above the throttle. This control turns off the instrument panel lights when it is rotated fully counterclockwise. As the rheostat is rotated clockwise the brightness of the instrument lights is increased.

**MAP LIGHT**

An optional map light may be installed on the AA-5B airplane. This light is mounted on the left side of the windshield, and consists of a light mounted on a flexible "gooseneck" shaft so that it can be positioned for map illumination. When a map light is installed, the dome light switch also operates the map light.

**CABIN HEATING, VENTILATING AND DEFROSTING SYSTEMS**

**HEATING-DEFROSTING SYSTEM**

Cabin heating and defrosting temperature is controlled by the CABIN HEAT control, located on the instrument panel above the throttle. When this control is pushed in cabin heating is decreased, and when it is pulled out cabin heating is increased. Figure 7-4 shows schematically the operation of the cabin heating, defrosting, and ventilation systems.

When cabin heat is turned on, and the sliding doors on the defrosting ducts are closed, the heat is applied through vents near the firewall into the cabin beneath the instrument panel.

When defrosting is desired, the sliding doors on the defrosting outlets (below the windshield), can be opened to apply hot air directly to the windshield.

### VENTILATION

As is shown in Figure 7-4, ventilation of the AA-5B airplane is accomplished by adjustable vents that provide fresh air individually controllable by each occupant.

Fresh air for the pilot and right front seat passenger is controlled by VENT controls located at the bottom left and right corners of the instrument panel. The air is directed through louvered vents directly to the front seat occupants.

Maximum ventilation can be obtained by sliding the canopy open to the placard marker on the canopy track at speeds up to 113 KIAS (130 MPH).

Fresh air ventilation for the rear cabin area (optional), is provided by adjustable vents located just forward of the rear arm rests. They are operated by a twisting motion and air may be directed by positioning the vent in the desired direction.

To obtain warm defrost air, pull out the cabin heat control (on the instrument panel) and slide open the defroster vents near the lower edge of the windshield. The fresh air vents also provide good defrost action when partially opened with the louvers directed toward the side canopy.

When cool and high humidity conditions exist, do not use partial defrost as the windshield may fog rapidly on takeoff. Always check defroster position before flight.

### NOTE

The heater system and fresh air system can be turned on simultaneously during cold weather operations to provide a comfortable cabin atmosphere.

**SECTION 7  
AIRPLANE & SYSTEMS  
DESCRIPTIONS**

**GULFSTREAM AMERICAN  
MODEL AA-5B TIGER**

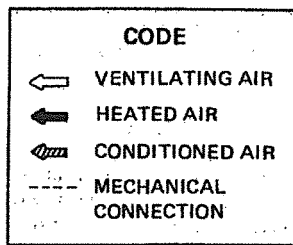
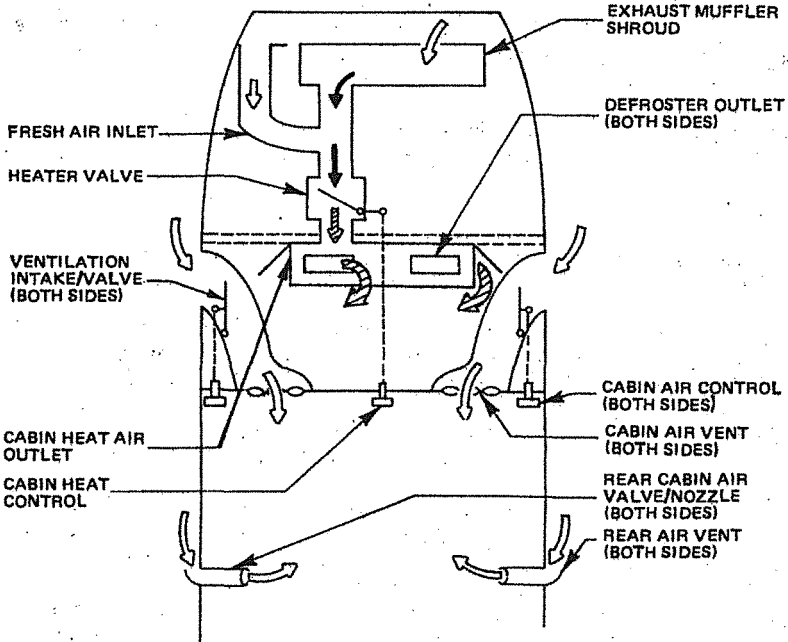

**Figure 7-4. Heating-Defrosting System**

### PITOT-STATIC SYSTEM AND INSTRUMENTS

The pitot-static system supplies ram air pressure to the airspeed indicator and static pressure to the airspeed indicator, vertical speed indicator and altimeter. The system is composed of a pitot tube mounted on the lower surface of the left wing, two external static ports, one on each side of the aft fuselage, and the associated plumbing necessary to connect the instruments to the sources. The static system also has a water drain.

The airplane may also be equipped with a pitot heat system. The system consists of a heating element in the pitot tube, a rocker-type switch labeled PITOT HEAT on the lower left side of the instrument panel, a 15 amp circuit breaker on the lower right side of the instrument panel, and associated wiring. When the pitot heat switch is turned on, the element in the pitot tube is heated electrically to maintain proper operation in possible icing conditions. Pitot heat should be used only as required.

An optional static pressure alternate source valve may be installed in the left side of the instrument panel for use if the external static source malfunctions. This valve supplies static pressure from inside the cabin instead of the external static ports.

If erroneous instrument readings are suspected due to water or ice in the pressure lines going to the standard external static pressure source, the alternate static source valve should be pulled on.

#### NOTE

Close the canopy when using the alternate static air source. If the IAS is above 87 KIAS (100 MPH) subtract 6 KIAS (7 MPH) from the airspeed and 80 feet from the indicated altitude.

### AIRSPEED INDICATOR

The airspeed indicator is calibrated in both knots (outer scale) and miles per hour (inner scale). The limitations and range markings are as follows:

Marking	Significance	KCAS	MPH
White Arc	Flap operating range	53-104	61-120
Green Arc	Normal operation	56-143	65-165
Yellow Arc	Caution range	143-174	165-200
Red Line	Never exceed speed	174	200

**SECTION 7  
AIRPLANE & SYSTEMS  
DESCRIPTIONS**

**GULFSTREAM AMERICAN  
MODEL AA-5B TIGER**

If a true airspeed indicator is installed, it is equipped with a rotatable ring which works in conjunction with the airspeed indicator dial in a manner similar to the operation of a flight computer. To operate the indicator, first rotate the ring until pressure altitude is aligned with outside air temperature in degrees Fahrenheit. Pressure altitude should not be confused with indicated altitude. To obtain pressure altitude, momentarily set the barometric scale on the altimeter to 29.92 and read pressure altitude on the altimeter. Be sure to return the altimeter barometric scale to the original barometric setting after pressure altitude has been obtained. Having set the ring to correct for altitude and temperature, then read the airspeed shown on the rotatable ring by the indicator pointer. For best accuracy, this indication should be corrected to calibrated airspeed by referring to the Airspeed Calibration chart in Section 5. Knowing the calibrated airspeed, read true airspeed on the ring opposite the calibrated airspeed.

**VERTICAL SPEED (RATE OF CLIMB) INDICATOR**

The vertical speed indicator depicts the airplane rate of climb or descent in feet per minute. The instrument is actuated by an atmospheric pressure change supplied by the static source.

**ALTIMETER**

Airplane altitude is depicted by a barometric type altimeter. A knob near the lower left portion of the indicator provides adjustment of the instrument's barometric scale to the proper barometric pressure reading.

**VACUUM SYSTEM AND INSTRUMENTS**

An engine-driven vacuum system (See Figure 7-5) is available and provides the suction necessary to operate the attitude indicator and directional indicator. The system consists of a vacuum pump mounted on the engine, a regulator and vacuum system air filter on the aft side of the firewall below the instrument panel, and instruments (including a suction gauge) on the instrument panel.

**ATTITUDE INDICATOR**

An attitude indicator is available and gives a visual indication of flight attitude. Bank attitude is presented by a pointer at the top of the indicator relative to bank scale which is marked in increments of 10°, 20°, 30°, 60°, and 90° either side of the center mark. Pitch attitude is presented by a miniature airplane in relation to the horizon bar. A knob at the bottom of the instrument is provided for in-flight adjustment of the miniature airplane to the horizon bar for a more accurate flight attitude indication.

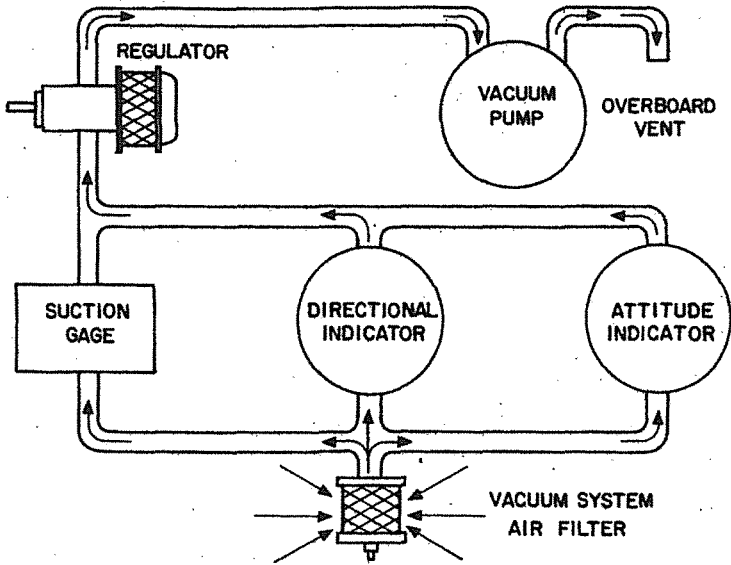

Figure 7-5. Vacuum System

### **DIRECTIONAL INDICATOR**

A directional indicator is available and displays airplane heading on a compass card in relation to a fixed simulated airplane image and index. The directional indicator will precess slightly over a period of time. Therefore, the compass card should be set in accordance with the magnetic compass just prior to takeoff, and occasionally re-adjusted on extended flights. A knob on the lower left edge of the instrument is used to adjust the compass card to correct for any precession.

### **SUCTION GAUGE**

A suction gauge is located at the upper right of the instrument panel. Suction available for operation of the attitude indicator and directional indicator is shown by this gauge, which is calibrated in inches of mercury. The desired suction range is 4.6 to 5.4 inches of mercury. A suction reading above or below this range may indicate a system malfunction or improper adjustment, and in this case, the indicators should not be considered reliable.

### **STALL WARNING SYSTEM**

The AA-5B airplane is equipped with an electrically operated stall warning system. Power to the system is supplied through the STALL HORN/OIL TEMP. fuse from the airplane electrical system.

A lift detector, located on the outboard leading edge of the right wing actuates the stall warning system. As the airspeed and angle of attack of the wing change to the extent that a stall condition is imminent, a portion of the air flow over the wing leading edge lifts the tab on the lift detector. The lift detector then completes a circuit that applies electrical power to the stall warning horn located under the instrument panel. The stall warning horn provides an aural indication of an impending stall at approximately 5 KIAS to 10 KIAS above the stall speed.

### **AVIONICS SUPPORT EQUIPMENT**

The AA-5B airplane may be equipped with a wide variety of avionics and its associated support equipment. Refer to the appropriate manufacturer's manuals for information regarding the avionics installed in your particular airplane.



## SECTION 8 AIRPLANE HANDLING SERVICE & MAINTENANCE

### TABLE OF CONTENTS

	Page
Introduction .....	8-3
Identification Plate .....	8-3
Publications .....	8-3
Airplane File .....	8-3
Airplane Inspection Periods .....	8-4
Pilot Conducted Preventive Maintenance .....	8-5
Alterations or Repairs .....	8-5
Ground Handling .....	8-5
Towing .....	8-5
Parking .....	8-6
Tie-Down .....	8-6
Jacking .....	8-6
Leveling .....	8-7
Flyable Storage .....	8-8
Servicing .....	8-8
Engine Oil .....	8-9
Oil Change .....	8-9
Fuel .....	8-12
Tire Service .....	8-12
Brake Service .....	8-12
Battery Service .....	8-12
Cleaning and Care .....	8-12
Exterior Care .....	8-12
Windshield, Canopy and Window Care .....	8-13
Propeller Care .....	8-14
Interior Care .....	8-14



## INTRODUCTION

This section contains the procedures recommended by Gulfstream American Corporation for the proper ground handling and routine care and servicing of your AA-5B airplane. Also included in this section are the inspection and maintenance requirements which must be followed if your airplane is to retain its performance and dependability. It is recommended that a planned schedule of lubrication and preventive maintenance be followed, and that this schedule be tailored to the climatic or flying conditions to which the airplane is subjected.

Much valuable knowledge and experience are available to you through your Gulfstream American Dealer. It is suggested that you take advantage of the services he offers, since he is an expert on your airplane and its maintenance. He will remind you when lubrications and oil changes are necessary, and about other seasonal or periodic services needed.

## IDENTIFICATION PLATE

All correspondence regarding your airplane should include its serial number. This number, together with the model number, type certificate number, and production certificate number are stamped on the identification plate attached to the left side of the fuselage beneath the horizontal stabilizer. On the upper left corner of the firewall is a plate giving the finish and trim code number of the particular airplane. This code number describes the interior color scheme and exterior paint combination of the airplane. This code number should be included in any correspondence regarding items requiring identification of color or trim.

## PUBLICATIONS

When the airplane is delivered from the factory it is supplied with a Pilot's Operating Handbook and supplemental data covering optional equipment installed in the airplane.

In addition, the owner may purchase the following:

- AA-5 Series Maintenance Manual
- AA-5 Series Illustrated Parts Catalog

## AIRPLANE FILE

Numerous data, information and licenses are required by Federal Aviation Regulations and by the Federal Communications Commission as parts of the airplane file. This file shall be maintained as a permanent record of the airplane. The applicable FAA regulations should be checked periodically by the owner to en-

**SECTION 8  
AIRPLANE HANDLING  
SERVICE & MAINTENANCE**

**GULFSTREAM AMERICAN  
MODEL AA-5B TIGER**

sure that the file is current. The following checklist contains a listing of required documents:

- (1) To be displayed in the airplane at all times:
  1. Aircraft Airworthiness Certificate (FAA Form 8100-2)
  2. Aircraft Registration Certificate (FAA Form 8050-3)
  3. Aircraft Radio Station License, if a transmitter is installed (FCC Form 556)
  4. All operating limitations placards.
- (2) To be carried in the airplane at all times:
  1. Weight and Balance, and associated papers (current copy of the Repair and Alteration Form FAA Form 337, if applicable)
  2. Equipment list.
- (3) To be available upon request:
  1. Airplane Log Book
  2. Engine Log Book

The items listed are required by the United States Federal Aviation Regulations and by the Federal Communications Commission (if a transmitter is installed). Regulations of other nations may require other documents or data, therefore, owners of airplanes not registered in the United States should check with their own aviation officials to determine the requirements of the nation the airplane is to be flown in.

In addition to the forms listed, Gulfstream American suggests that the Pilot's Operating Handbook be kept in the airplane at all times.

#### **AIRPLANE INSPECTION PERIODS**

As required by Federal Aviation Regulations, all civil airplanes of U.S. registry must undergo a complete inspection (annual) each twelve (12) calendar months. In addition to the required annual inspection, airplanes operated commercially (for hire) must have a complete inspection every 100 hours of operation.

The FAA may require other inspections by issuance of airworthiness directives applicable to the airplane, engine, propeller and components. It is the responsibility of the owner/operator to ensure compliance with all applicable airworthiness directives and, when the inspections are repetitive, to take appropriate steps to prevent inadvertent noncompliance.

Revised February 15, 1979

### PILOT CONDUCTED PREVENTIVE MAINTENANCE

A certificated pilot who owns or operates an airplane not used as an air carrier is authorized by FAR Part 43 to perform limited maintenance on his airplane. Refer to FAR Part 43 for a list of the specific maintenance operations which are allowed.

#### NOTE

Pilots operating airplanes of other than U.S. registry should refer to the regulations of the country of certification for information on preventive maintenance that may be performed by pilots.

A Maintenance Manual should be obtained prior to performing any preventive maintenance to ensure that proper procedures are followed. Your Gulfstream American Dealer should be contacted for further information or for required maintenance which must be accomplished by appropriately licensed personnel.

### ALTERATIONS OR REPAIRS

It is essential that the FAA be contacted prior to any alterations on the airplane to ensure that airworthiness of the airplane is not violated. Alterations or repairs to the airplane must be accomplished by licensed personnel.

### GROUND HANDLING

#### TOWING

Towing of the airplane should be accomplished by the use of the nose gear tow bar.

#### CAUTION

USING THE PROPELLER FOR GROUND HANDLING COULD RESULT IN SERIOUS DAMAGE, ESPECIALLY IF PRESSURE IS EXERTED ON THE OUTER ENDS. DO NOT ATTEMPT TO PUSH THE AIRPLANE BACKWARD OR FORWARD WITHOUT THE AID OF A TOW BAR. THIS ACTION COULD RESULT IN THE NOSE WHEEL PIVOTING ABRUPTLY AND DAMAGING THE NOSE WHEEL STOPS.

### **PARKING**

When parking, head the airplane into the wind. Do not set the parking brakes during cold weather when accumulated moisture may freeze the brakes, or when the brakes are overheated.

Care should be taken when using the parking brakes for an extended period of time during which an air temperature rise could cause the hydraulic fluid to expand. This in turn, could damage the brake system and/or cause difficulty in releasing the parking brake. For prolonged parking, tie-downs and wheel chocks are recommended.

Install the control wheel lock and chock the wheels. In severe weather and high wind conditions, tie the airplane down as outlined in the following paragraph.

### **CAUTION**

**WHEN USING CHOCKS ENSURE THAT THE CHOCKS DO NOT CONTACT THE LANDING GEAR WHEEL FAIRINGS. USING CHOCKS THAT ARE TOO HIGH COULD RESULT IN DAMAGE TO WHEEL FAIRINGS.**

### **TIE-DOWN**

Proper tie-down procedure is the best precaution against damage to the parked airplane by gusty or strong winds. To tie-down the airplane securely, proceed as follows:

- (1) Chock all wheels and install the control wheel lock.
- (2) Tie sufficiently strong ropes or chains (700 pounds tensile strength) to the wing and tail tie-down fittings and secure each rope to a ramp tie-down.
- (3) Ensure that the canopy is closed and latched.

### **JACKING**

When it is necessary to jack the entire airplane off the ground, or when jack points are used in the jacking operation, refer to the Maintenance Manual for specific procedures and equipment required.

If nose gear maintenance is required, the nose wheel may be raised off the ground by pressing down on the root of the horizontal stabilizer.

**CAUTION**

**DO NOT ALLOW THE TAIL OF THE AIRPLANE TO CONTACT THE GROUND AS TAIL CONE AND/OR ELEVATOR DAMAGE MAY RESULT.**

**NOTE**

Do not apply pressure on the outboard horizontal stabilizer surfaces. When pushing on the tail cone, always apply pressure at the root of the horizontal stabilizer to avoid buckling the skin.

Ensure that the nose will be held off the ground under all conditions by means of suitable stands or supports under the firewall of the airplane. (See jacking instructions in the Maintenance Manual.)

**LEVELING**

Level the airplane as described in Section 6.

**FLYABLE STORAGE**

Airplanes placed in storage for a maximum of 30 days or those which receive only intermittent use for the first 25 hours are considered in flyable storage. Every seventh day during these periods, the propeller should be rotated by hand through several revolutions. This action "limbers" the oil and prevents any accumulation of corrosion on engine cylinder walls.

**WARNING**

**CHECK THAT THE IGNITION SWITCH IS OFF, THE THROTTLE IS CLOSED, THE MIXTURE CONTROL IS IN THE IDLE CUT-OFF POSITION, AND THE AIRPLANE IS SECURED BEFORE ROTATING THE PROPELLER BY HAND. DO NOT STAND WITHIN THE ARC OF THE PROPELLER BLADES WHILE TURNING THE PROPELLER.**

After 30 days in storage, the airplane should be flown for at least 30 minutes, or a ground runup should be made just long enough to produce an oil temperature within the lower green arc range. Excessive ground runup should be avoided.

Engine runup helps to eliminate excessive accumulations of water in the fuel system and other air spaces in the engine. Keep fuel tanks full to minimize condensation in the tanks. Keep the battery fully charged to prevent the electrolyte from freezing in cold weather.

**SERVICING (See Figure 8-1.)**

In addition to the preflight inspection in Section 4, servicing, inspection, and test requirements for your airplane are detailed in the Maintenance Manual. The Maintenance Manual outlines all items which require attention at 50, 100, and 1000 hour intervals plus those items which require servicing, inspection, and/or testing at special intervals.



For quick and ready reference, quantities, materials, and specifications for frequently used service items are as follows:

#### ENGINE OIL

Average Ambient Air Temperature	Mineral Grade	Ashless Dispersant
Above 60°F (16°C)	SAE 50	SAE 40 or SAE 50
30°F (-1°C) to 90°F (32°C)	SAE 40	SAE 40
0°F (-18°C) to 70°F (21°C)	SAE 30	SAE 40 or SAE 30
Below 10°F (-12°C)	SAE 20	SAE 30

Multi-viscosity oil with a range of SAE 10W30 is recommended for improved starting in cold weather. Ashless dispersant oil, conforming to Specification No. MIL-L-22851 (Figure 1-2) must be used.

#### NOTE

Your AA-5B was delivered from the factory with a corrosion preventive aircraft engine oil. If oil must be added during the first 25 hours of engine operation, use only aviation grade straight mineral oil conforming to Specification No. MIL-L-6082 (Figure 1-2).

#### CAPACITY OF ENGINE SUMP – 8 QUARTS

Do not operate on less than 6 quarts. To minimize loss of oil through the breather, fill to 7 quart level for normal flights of less than 3 hours. For extended flight, fill to 8 quarts. These quantities refer to oil dipstick level readings.

#### OIL CHANGE

After the first 25 hours of operation, drain engine oil sump and oil cooler, and clean the oil suction strainer. Refill sump with straight mineral oil and use until a total of 50 hours has accumulated; then change to dispersant oil. Drain the engine oil sump and clean oil suction strainer, each 50 hours thereafter. Change engine oil at least every 6 months even though less than the recommended hours have accumulated. Reduce intervals for prolonged operation in dusty areas, cold climates, or when short flights and long idle periods result in sludging conditions.

**SECTION 8  
AIRPLANE HANDLING  
SERVICE & MAINTENANCE**

**GULFSTREAM AMERICAN  
MODEL AA-5B TIGER**

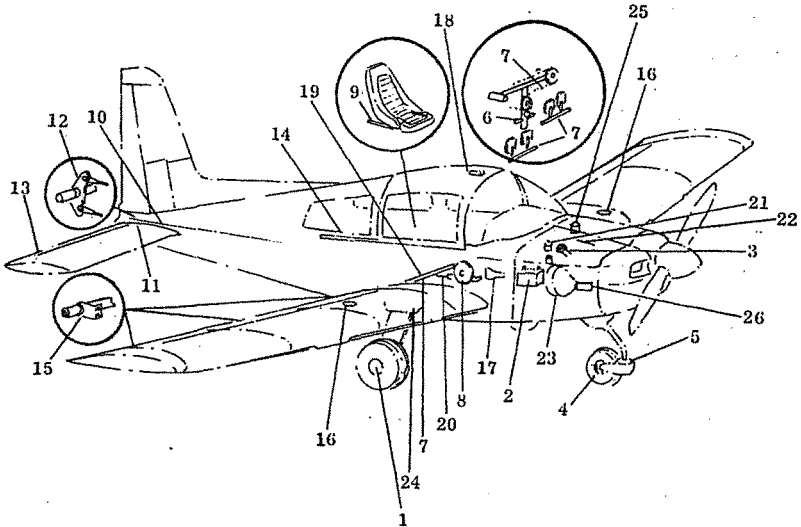

1. MAIN WHEEL BEARINGS (LEFT AND RIGHT) – Grease with MIL-G-25760 (Figure 1-2) grease every 100 hours or as required.  
TIRES – Inflate to 34 PSI as required.
2. BATTERY TERMINALS – Coat with VV-P-236 (Figure 1-2) petrolatum as required to prevent corrosion.  
BATTERY – Fill with distilled water as required to maintain fluid level at top of plate.
3. ENGINE OIL – (See Figure 1-2.) Change engine oil every 50 hours. Add oil as required to maintain safe level. See Section 8 for recommended seasonal grades.
4. NOSE WHEEL BEARINGS – Grease with MIL-G-25760 (Figure 1-2) grease every 100 hours or as required.  
NOSE WHEEL TIRE – Inflate to 25 PSI as required.
5. NOSE FORK SWIVEL AND BELLVILLE WASHERS – Grease with MIL-G-7711 (Figure 1-2) grease every 100 hours.
6. T-COLUMN NEEDLE BEARING – Grease with MIL-G-7711 (Figure 1-2) grease as required.
7. RUDDER AND FLAP TORQUE TUBE OILITE BEARING AND ROLLER CHAIN (NOTE 1) – Oil with MIL-L-7870 (Figure 1-2) as required.

**Figure 8-1. Servicing Points (Sheet 1 of 2)**

8. TRIM WHEEL GEARS — Grease with MIL-G-7711 (Figure 1-2) grease every 100 hours.
9. SEAT TRACKS — Oil with MIL-L-7870 (Figure 1-2) oil every 100 hours.
10. TRIM ACTUATOR SHAFT — Grease with MIL-G-7711 (Figure 1-2) grease as required.
11. TRIM TAB BELLCRANKS — Oil with MIL-L-7870 (Figure 1-2) oil as required.
12. RUDDER AND ELEVATOR BELLCRANK CLEVIS PINS — Oil with MIL-L-7870 (Figure 1-2) oil as required.
13. TRIM TAB HINGE — Oil with MIL-L-7870 (Figure 1-2) oil (Note 2).
14. CANOPY SLIDES — Spray with E-Z-Free lubricant as required.
15. ALL CONTROL SURFACE BEARINGS — Grease with MIL-G-7711 (Figure 1-2) or AeroShell #6 grease as required. (Note 3.)
16. FUEL SELECTOR VALVE AND FUEL CAP GASKET — Grease with MIL-G-6032A (Figure 1-2) grease as required.  
FUEL TANKS — Fill with 100/130 grade aviation fuel as required.
17. FRESH AIR VENTS — Oil with MIL-L-7870 (Figure 1-2) oil as required.
18. CANOPY LATCH — Grease with white grease, Lubriplate #501 or equivalent as required.
19. FLAP DRIVE JACKSCREW — Oil with MIL-L-7870 (Figure 1-2) oil. Coat with a light film for corrosion prevention only.
20. FLAP POSITION INDICATOR CABLE — Grease with MIL-G-21164 (Figure 1-2) Molybdenum Disulphide grease as required.
21. BRAKE RESERVOIRS — Fill to within 1/4 inch of top with MIL-H-5606 (Figure 1-2) hydraulic fluid, as required.
22. VACUUM SYSTEM FILTER — Replace filter element as required.
23. ENGINE AIR FILTER — On aircraft with foam type filter, Part No. 55000015-501, replace filter element every 300 hours, or when torn or 50% covered with foreign material. On 1979 model aircraft with paper type filter, Part No. 7SCF024-1 installed, change filter every 500 hours or after ten cleanings. Refer to Maintenance Manual for cleaning instructions.
24. FUEL SUMP DRAINS AND TANK — Clear of water and sediment prior to first flight of day.
25. AUXILIARY FUEL PUMP FILTER — Clean filter element every 50 hours.
26. CARBURETOR FILTER — Drain carburetor bowl and clean filter every 100 hours.

**NOTES:**

1. Do not lubricate roller chains except under seacoast conditions. Wipe with a clean, dry cloth.
2. Acceptable substitute is powdered graphite MIL-G-6711 (Figure 1-2).
3. Elevator bearings do not require lubrication.

Figure 8-1. Servicing Points (Sheet 2 of 2)

**SECTION 8  
AIRPLANE HANDLING  
SERVICE & MAINTENANCE**

**GULFSTREAM AMERICAN  
MODEL AA-5B TIGER**

**FUEL**

**GRADE (COLOR) – 100/130 Minimum Grade Aviation Fuel (green.) 100 Low Lead Aviation Fuel (blue) is also approved.**

**CAPACITY EACH TANK – 26.3 Gallons.**

**TIRE SERVICE**

All tires and wheels are balanced at the factory prior to original installation. A similar relationship of the tire, tube and wheel should be maintained. If vibration is encountered, it may be due to out-of-round or out-of-balance conditions. When wheel, tire or tube is replaced due to wear, it is recommended that they be re-balanced.

**NOSE WHEEL TIRE PRESSURE – 25 PSI on 5.00-5, 4-Ply Rated Tire.**

**MAIN WHEEL TIRE PRESSURE – 35 PSI on 6.00-6, 6-Ply Rated Tires.**

**BRAKE SERVICE**

The brake system reservoirs, located on the pilot's brake master cylinders, should be filled to within 1/4 inch of the reservoir top with hydraulic fluid conforming to MIL-H-5606 (Figure 1-2).

**BATTERY SERVICE**

The battery is accessible by opening the top cowl. The battery is equipped with an overboard vent and drain. The battery is rated at 12 volt, 25 ampere-hours. It should be inspected periodically for proper fluid level. If the fluid level is found to be low, fill as recommended by the battery manufacturer. **DO NOT** fill above the visible battery baffle plates.

**CLEANING AND CARE**

**EXTERIOR CARE**

The painted surfaces of the airplane have a long-lasting, all-weather finish and should require no buffing or rubbing out in normal conditions. However, it is desirable to wax and polish it to preserve the outstanding exterior finish. It is recommended that wax or polish operations be delayed at least 60 days after date of certification to allow proper curing of the paint.

The paint can be kept bright simply by washing with water and mild soap. Avoid abrasive or harsh detergents. Rinse with clear water and dry with terry cloth towels or chamois. Oil and grease spots may be removed with kerosene or mineral spirits.

#### NOTE

No commercial paint removers are to be used on any airframe component unless specific prior approval has been received from the factory (See Maintenance Manual).

If you choose to wax your airplane, use a good automotive-type wax applied as directed. The use of wax in areas subject to high abrasion, such as leading edges of wings and tail surfaces, propeller spinner and blades, is recommended.

#### WINDSHIELD, CANOPY AND WINDOW CARE

It is recommended that you keep the plexiglas in the canopy, windshield and cabin windows clean and unscratched. The following procedures are recommended:

1. If large deposits of mud and/or dirt have accumulated on the plexiglas, flush with clean water. Rubbing with your hand is recommended to dislodge excess dirt and mud without scratching the plexiglas.
2. Wash with soap and water. Use a sponge or heavy wadding of a soft cloth. DO NOT rub, as the abrasive action in the dirt and mud residue will cause fine scratches in the surface.
3. Grease and oil spots may be removed with a soft cloth soaked in kerosene.
4. After cleaning, wax the plexiglas surface with a thin coat of hard polish-wax.
5. If a severe scratch or marring occurs, jeweler's rouge is recommended. Follow directions, rub out scratch, smooth, apply wax and buff.

#### CAUTION

NEVER USE GASOLINE, BENZINE, ALCOHOL, ACETONE, CARBON TETRACHLORIDE, FIRE EXTINGUISHER FLUID, ANTI-ICE FLUID, LACQUER THINNER OR GLASS CLEANER TO CLEAN PLASTIC. THESE MATERIALS WILL DAMAGE THE PLASTIC AND MAY CAUSE SEVERE CRAZING.

### PROPELLER CARE

Damage from foreign objects, sometimes referred to as "nicks", may appear in the leading edges of the propeller from time to time. It is vital that these nicks be corrected as quickly as possible. Such minor damage may cause stress concentrations and result in cracks forming in the propeller. Keep the blades clean and free of dirt or grass build-up. This type of foreign material on the propeller may cause an imbalance and accompanying vibration. We recommend cleaning agents such as Stoddard solvent or equivalent followed by waxing or coating with a light film of oil.

### INTERIOR CARE

Clean the interior regularly with a vacuum cleaner to remove dust and loose dirt from the upholstery and carpet.

If liquid (coffee, etc.) is spilled on the upholstery or carpet, blot it up promptly with cleansing tissue or rags. Continue blotting until no more liquid is taken up. Sticky materials may be scraped up with a dull knife, then cleaned up with a spot remover.

Oily spots may be cleaned with household spot removers, used sparingly. Before using any solvent, read the instructions on the container and test it on an obscure place on the fabric to be cleaned. Never saturate the fabric with a volatile solvent; it may damage the padding and backing materials.

Soiled upholstery and carpet may be cleaned with foam-type detergent, used according to the manufacturer's instructions. To minimize wetting the fabric, keep the foam as dry as possible and remove it with a vacuum cleaner.

The plastic trim, headliner, instrument panel and control knobs need only be wiped off with a damp cloth. Oil and grease on the control wheel and control knobs can be removed with a cloth moistened with Stoddard solvent. Volatile solvents, such as mentioned in paragraphs on care of the windshield, must never be used since they soften and craze the plastic.

**SECTION 9  
SUPPLEMENTS  
(Optional Systems Description &  
Operating Procedure)**

TABLE OF CONTENTS

	Page
Introduction .....	9-3
Supplements: .....	

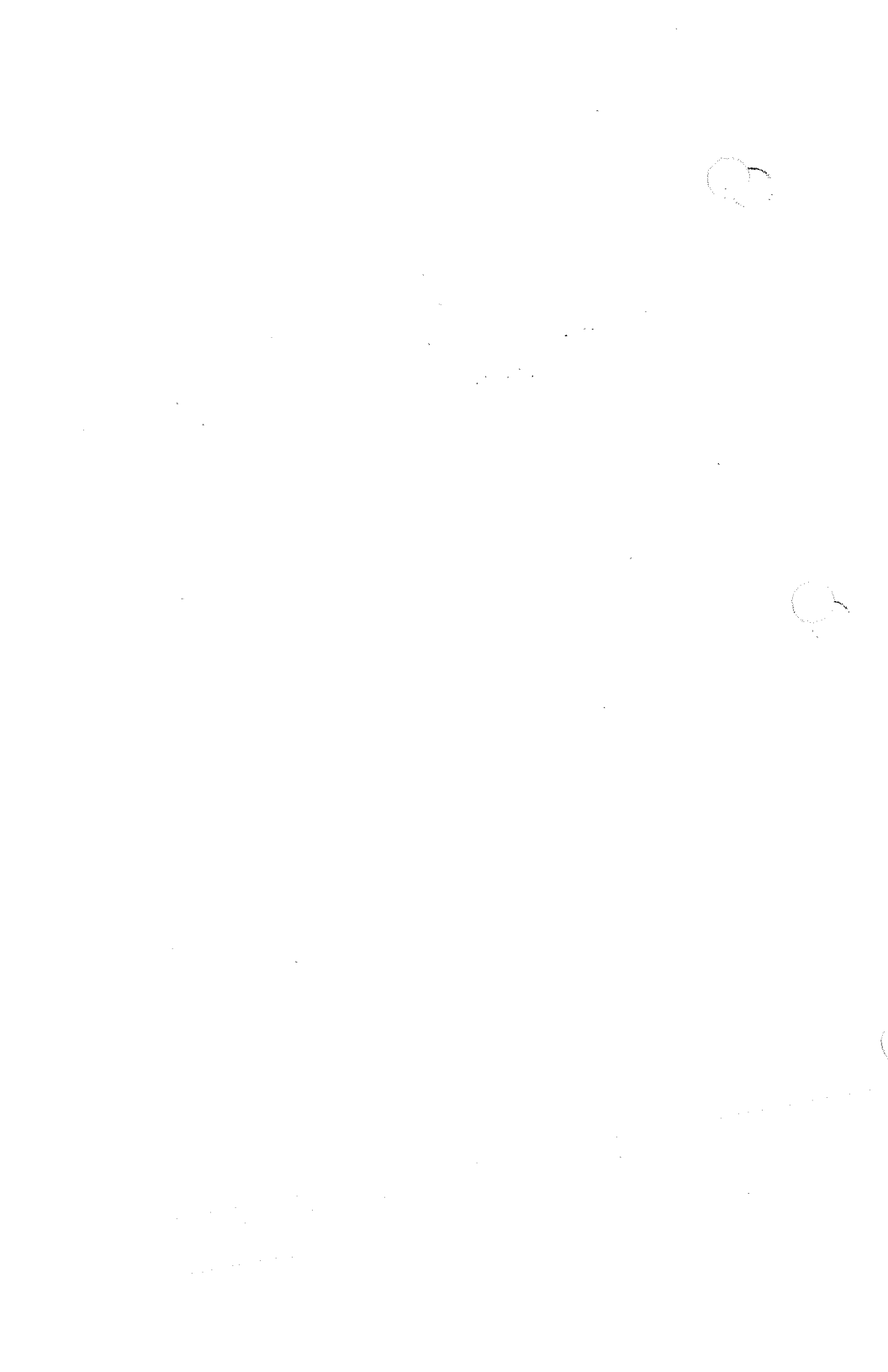



**INTRODUCTION**

This section consists of a series of supplements, each covering a single optional system which may be installed in the airplane. Each supplement contains a brief description, and when applicable, operating limitations, emergency and normal procedures, and performance. Other routinely installed items of optional equipment, whose function and operational procedures do not require detailed instructions, are discussed in Section 7.



## SECTION 10 SAFETY INFORMATION

### TABLE OF CONTENTS

	Page
Introduction .....	10-3
General .....	10-3
Do's .....	10-3
Don'ts .....	10-4
General Sources of Information .....	10-5
Rules and Regulations .....	10-5
Federal Aviation Regulations, Part 39, Airworthiness Directives .....	10-6
Airman Information, Advisories, and Notices — FAA Airman's Information Manual .....	10-6
Advisory Information .....	10-6
General Information or Specific Topics .....	10-7
Flight Planning .....	10-7
Inspection — Maintenance .....	10-7
Special Conditions and Precautions .....	10-8
Walk-Around Inspections .....	10-8
Cockpit Checks .....	10-9
Flight Operations .....	10-9
General .....	10-9
Engine Operation in Flight .....	10-9
Turbulent Weather .....	10-10
Flight in Turbulent Air .....	10-10
Flight in Icing Conditions .....	10-11
Mountain Flying .....	10-11
VFR — Low Ceilings .....	10-11
VFR at Night .....	10-12

TABLE OF CONTENTS (Continued)

	Page
Vertigo -- Disorientation . . . . .	10-12
Stalls, Spins and Slow Flight . . . . .	10-12
Vortices -- Wake Turbulence . . . . .	10-13
Takeoff and Landing Conditions . . . . .	10-13
Medical Facts for Pilots . . . . .	10-14
General . . . . .	10-14
Fatigue . . . . .	10-14
Hypoxia . . . . .	10-14
Hyperventilation . . . . .	10-15
Alcohol . . . . .	10-15
Drugs . . . . .	10-15
Scuba Diving . . . . .	10-15
Additional Information . . . . .	10-16

## INTRODUCTION

Your Gulfstream American airplane is a responsive, high-performance vehicle, designed to provide you with safe and efficient transportation. Like any other airplane, your Gulfstream American airplane operates most efficiently and safely in the hands of a skilled pilot.

We urge you to be thoroughly familiar with the contents of this handbook, placards, and checklists to ensure maximum utilization of your airplane. When the airplane was delivered, it was equipped with a Pilot's Operating Handbook, engine operator's manual, weight and balance information and placards. If the airplane has changed ownership, some of these may have been misplaced. If any are missing, replacements should be obtained as soon as possible.

We have added this special section of safety information to refresh owners' and pilots' knowledge of a number of safety subjects. We strongly recommend these subjects be reviewed periodically, along with other documents required for operation of the airplane.

Topics in this publication are mostly excerpts from FAA Documents and other articles pertaining to the subject of safe flying. They are not limited to any particular make or model airplane and do not replace instructions for particular types of airplanes.

Your Gulfstream American airplane is built to provide you with many years of safe and efficient transportation. By maintaining it properly and flying it prudently, you will realize its full potential.

## GENERAL

Flying can be one of the safest modes of travel. Remarkable safety records are being established each year. As a pilot you are responsible to yourself, your relatives, to those who travel with you, to other pilots and to ground personnel to fly wisely and safely.

The following material in this Safety section covers several subjects in limited detail. Here are some condensed Do's and Don'ts.

### DO'S

Be thoroughly familiar with your airplane. If you are not current in your airplane, get a check ride.

**SECTION 10  
SAFETY INFORMATION**

**GULFSTREAM AMERICAN  
MODEL AA-5B TIGER**

Pre-plan all aspects of your flight. Include in your pre-planning a complete weather briefing.

Use all services available when needed (FSS, Weather Bureau, etc.)

Prior to takeoff, ensure that a complete pre-flight inspection has been performed.

Use your checklists.

Use seat belts and shoulder harness.

Prior to takeoff ensure that you have enough fuel aboard the airplane to make the intended trip and arrive at your destination with an adequate reserve.

Prior to takeoff ensure that the airplane weight and C.G. are within limits for the type of flying intended.

Be sure that articles and baggage are secured.

Check freedom of all controls.

Maintain an appropriate airspeed in takeoff, climb, descent and landing.

Remain alert to see and avoid other aircraft traffic.

Avoid big airplane wake turbulence.

Switch fuel tanks before you have to.

Keep your airplane in good mechanical condition.

Stay informed and alert, fly in a sensible manner.

**DON'TS**

Don't takeoff with frost, ice or snow on the airplane surfaces.

Don't takeoff with less than minimum recommended fuel, plus reserves.

Don't fly in a reckless, show off, or careless manner.

Don't fly into thunderstorms or severe weather.

Issued: September 30, 1976

Don't fly into possible icing conditions.

Don't fly close to mountainous terrain.

Don't apply controls abruptly or with high forces that could exceed design loads of the airplane.

Don't fly when physically or mentally under par.

Don't trust to luck.

### **GENERAL SOURCES OF INFORMATION**

The FAA and various aviation service agencies provide the pilot with a wealth of information. This information is provided for the sole purpose of making your flying easier, faster, and safer. Take advantage of this knowledge and be prepared for an emergency in the event that one should occur. Your responsibilities as a pilot are clearly defined by government regulations. Since these regulations are designed for your own protection, compliance with them is not only mandatory, but beneficial to you.

### **RULES AND REGULATIONS**

Federal Aviation Regulations, Part 91, General Operating and Flight Rules, is a document of law governing operation of aircraft and the owner's and pilot's responsibilities.

Part 91 includes such subjects as:

- Responsibilities and authority of the pilot in command.
- Certificates required.
- Liquor and drug usage
- Flight plans
- Pre-flight action
- Fuel requirements
- Flight rules
- Maintenance, preventative maintenance, alterations, inspections, and maintenance records.

These are only some of the topics covered. It is the owner's and pilot's responsibility to be thoroughly familiar with all regulations in FAR Part 91 and to follow them.

**SECTION 10  
SAFETY INFORMATION**

**GULFSTREAM AMERICAN  
MODEL AA-5B TIGER**

**FEDERAL AVIATION REGULATIONS, PART 39, AIRWORTHINESS  
DIRECTIVES**

This document specifies that no person may operate an aircraft to which an airworthiness directive (issued by the FAA) applies, except in accordance with the requirements of that airworthiness directive. It is the responsibility of the owner or pilot to ensure that the airplane he intends to fly is in compliance with all applicable airworthiness directives before the airplane is operated.

**AIRMAN INFORMATION, ADVISORIES, AND NOTICES — FAA AIRMAN'S  
INFORMATION MANUAL**

This document contains a wealth of pilot information for nearly all realms of flight, including navigation, ground procedures, and medical information. Among the subjects discussed are:

- Controlled Air Space
- Services Available to Pilots
- Radio Phraseology and Technique
- Airport Operations
- Clearances and Separations
- Pre-flight
- Departures — IFR
- Enroute — IFR
- Arrival — IFR
- Emergency Procedures
- Weather
- Wake Turbulence
- Medical Facts for Pilots
- Bird Hazards
- Good Operating Practices
- Airport Location Directory

We urge all pilots to be thoroughly familiar with and use the information in this handbook.

**ADVISORY INFORMATION**

Airmen can subscribe to services that provide FAA NOTAMS and Airman Advisories. These documents are also available at most FAA Flight Service Stations, and at many Fixed Base Operations. When using these documents, ensure that they are current prior to using the information in them for flight planning.



NOTAMS are documents that provide information of a time-critical nature affecting a pilot's decision to make an intended flight. For example, closed airports, terminal radar out of service, enroute navigational aids out of service, etc.

### GENERAL INFORMATION ON SPECIFIC TOPICS

#### FLIGHT PLANNING

FAR, Part 91 requires that each pilot in command, before beginning a flight, familiarize himself with all available information concerning that flight.

All pilots are urged to obtain a complete pre-flight briefing, preferably from an expert such as an FSS briefer. The pre-flight briefing should consider such items as local, enroute and destination weather; alternate airports; enroute nav aids; airport runways in use; length of runways; takeoff and landing performance of the airplane under expected conditions; etc.

The prudent pilot will review his planned enroute track and stations and make a list for quick reference. It is strongly recommended that a flight plan be filed with Flight Service Station even though the flight may be VFR. Also, advise Flight Service Stations of changes or delays of one hour or more in flight plans and remember to close the flight plan at your destination.

The pilot must be completely familiar with the performance of his airplane including performance data in the airplane manuals and placards. The resultant effect of temperature and pressure altitude must be taken into account in determining performance if not accounted for on the charts. Applicable FAA weight and balance forms must be aboard the airplane at all times.

The airplane must be loaded so that its maximum weight and center of gravity (C.G.) limitations are not exceeded. Also, enough fuel must be aboard to ensure that the intended trip can be made with sufficient reserve fuel remaining. The engine oil level should be checked and brought to the proper level prior to flight.

#### INSPECTIONS — MAINTENANCE

In addition to maintenance inspections and pre-flight information required by FAR Part 91, a complete pre-flight inspection is imperative. It is the responsibility of the owner and operator to assure that the airplane is maintained in an airworthy condition and proper maintenance records are kept.

While the following items cannot substitute for the pre-flight specified for each type of airplane, they will serve as reminders of general items that should be checked.

#### SPECIAL CONDITIONS AND PRECAUTIONS

##### NOTE

Airplanes operated in humid tropics or cold and damp climates, etc., may need more frequent inspections for wear, corrosion and/or lack of lubrication. In these areas periodic inspections should be performed until the operator can set his own inspection periods based on experience. The required periods do not constitute a guarantee that the item will reach the period without malfunctions, as the above factors cannot be controlled by the manufacturer.

Corrosion, and its effects, must be treated at the earliest possible opportunity. A clean dry surface is virtually immune to corrosion. Make sure that all drain holes remain unobstructed. Protective films and sealants help to keep corrosive agents from contacting metallic surfaces. Corrosion inspections should be made most frequently under high-corrosion-risk operating conditions, such as in areas of high airborne salt concentrations (e.g., near the sea) and high-humidity areas (e.g., tropical regions).

#### WALK-AROUND INSPECTIONS

All airplane surfaces free of ice, frost or snow.  
Tires properly inflated.  
All external locks, covers and tie downs removed.  
Fuel sumps drained, fuel checked for proper color, absence of water or sediment.  
Fuel quantity, adequate for trip, plus reserve, visually checked.  
Oil quantity checked and access doors secured.  
General condition of airplane, engine, propeller, exhaust stack, etc., checked.  
All external doors secured.

### **COCKPIT CHECKS**

Flashlight available.  
Required documents on board.  
Use the checklist.  
All internal control locks removed.  
Freedom of controls checked.  
Canopy properly closed and latched.  
Seat belts and shoulder harnesses fastened.  
Passengers briefed.  
Engine operating satisfactorily.  
All engine gauges checked for proper readings.  
Fuel selector in proper position.  
Fuel quantity checked by gauges.  
Altimeter setting checked.  
Carburetor heat control checked.

### **FLIGHT OPERATIONS**

#### **GENERAL**

The pilot should be thoroughly familiar with all information published by the manufacturer concerning the airplane. He is required by FAA regulations to operate in accordance with the placards installed.

#### **ENGINE OPERATION IN FLIGHT**

In addition to leaning, the following techniques should be considered to minimize spark plug lead fouling:

1. Exchange top spark plugs with bottom spark plugs at mid-spark plug servicing periods (50 hours).
2. Avoid closed throttle idle operation on the ground whenever possible. Try to idle engine in the 1000 to 1200 RPM range whenever conditions permit.
3. Ensure that the idle mixture has been properly adjusted to avoid a rich condition.
4. Rather than closing the throttle, use other means to lower airspeed or altitude. Power landings prevent rapid temperature drop; retaining the advantage of proper operating temperature.
5. Use the correct heat range spark plugs.

**TURBULENT WEATHER**

A complete weather briefing prior to beginning a flight is an essential element of a safe trip.

Updating of weather information enroute is another safety aid. However, the wise pilot also knows weather conditions change quickly at times and treats weather forecasting as professional advice rather than an absolute fact. He obtains all the advice he can, but still stays alert by using his knowledge of weather conditions.

Plan the flight to avoid areas of severe turbulence and thunderstorms. It is not always possible to detect individual storm areas or find the in-between clear areas.

Thunderstorms, squall lines and violent turbulence should be regarded as extremely dangerous and avoided. The hail and tornadic wind velocities encountered in thunderstorms can destroy any airplane, just as tornados destroy nearly everything in their path on the ground.

A roll cloud ahead of a squall line or thunderstorm is visible evidence of violent turbulence. However, the absence of a roll cloud should not be interpreted as denoting the lack of turbulence.

**FLIGHT IN TURBULENT AIR**

Even though flight in severe turbulence is to be avoided, flight in turbulent air may be encountered under certain conditions.

Flying through turbulent air presents two basic problems, to both of which the answer is proper airspeed. If you maintain an excessive airspeed, you run the risk of structural damage or failure, or if your airspeed is too low, you run the risk of stalling.

If turbulence encountered in cruise or descent becomes uncomfortable to the pilot or passengers, the best procedure is to reduce speed to the maneuvering speed, listed in the limitations section of this handbook. This speed gives the best assurance of avoiding excessive stress loads, and at the same time provides a margin of airspeed to prevent inadvertent stalls due to gusts.

Beware of overcontrolling in attempting to correct for changes in altitude; applying control pressure abruptly will build up g-forces rapidly and could cause damaging structural stress loads. You should watch particularly your angle of bank, making turns as wide and shallow as possible, and be equally cautious in applying forward or back pressure to keep the nose level. Maintain straight and level attitude in either up or down drafts. Use trim sparingly to avoid being grossly mistrimmed as the vertical air columns change velocity and direction.

#### FLIGHT IN ICING CONDITIONS

An airplane which does not have all critical areas protected in a proper manner must not be exposed to icing encounters — the pilot should make an immediate 180 degree turn or seek a different altitude when icing conditions are encountered.

#### MOUNTAIN FLYING

Avoid flight at low altitudes over mountainous terrain, particularly near the lee slopes. If the wind velocity near the level of the ridge is in excess of 25 knots and approximately perpendicular to the ridge, mountain wave conditions are likely over and near the lee slopes. If the wind velocity at the level of the ridge exceeds 50 knots, a strong mountain wave is probable with strong up and down drafts and severe or extreme turbulence. The worst turbulence will be encountered in and below the rotor zone which is usually 8 to 10 miles downwind from the ridge. This zone is characterized by the presence of "roll clouds" if sufficient moisture is available; altocumulus standing lenticular clouds are also visible signs that a mountain wave exists, but their presence is likewise dependent upon moisture. Mountain wave turbulence can, of course, occur in dry air and the absence of such clouds should not be taken as any assurance that mountain wave turbulence will not be encountered. A mountain wave downdraft may exceed the climb capability of your airplane. Avoid mountain wave downdrafts.

#### VFR — LOW CEILINGS

If you are not instrument rated, avoid "VFR On Top" and "Special VFR". Being caught above an undercast when an emergency descent is required (or at destination) is an extremely hazardous position for the VFR pilot. Accepting a clearance out of certain airport control zones with no minimum ceiling and one-mile visibility as permitted with "Special VFR" is not a recommended practice for a VFR pilot.

Avoid areas of low ceilings and restricted visibility unless you are instrument proficient and have an instrument equipped airplane, then proceed with caution and have planned alternates.

### VFR AT NIGHT

When flying VFR at night, in addition to the altitude appropriate for the direction of flight, pilots should maintain a safe minimum altitude as dictated by terrain, obstacles such as TV towers, or communities in the area flown. This is especially true in mountainous terrain, where there is usually very little ground reference and absolute minimum clearance is 2,000 feet. Don't depend on your being able to see obstacles in time to miss them.

### VERTIGO – DISORIENTATION

Disorientation can occur in a variety of ways. During flight, inner ear balancing mechanisms are subjected to varied forces not normally experienced on the ground. This combined with loss of outside visual reference can cause vertigo. False interpretations (illusions) result and may confuse the pilot's conception of the attitude and position of his airplane.

Under VFR conditions the visual sense, using the horizon as a reference, can override the illusions. Under low visibility conditions (night, fog, clouds, haze, etc.) the illusions predominate. Only through awareness of these illusions, and proficiency in instrument flight procedures, can an airplane be operated safely in a low visibility environment.

Flying in fog, dense haze or dust, cloud banks, or very low visibility, with strobe lights, and particularly rotating beacons turned on, frequently causes vertigo. They should be turned off in these conditions, particularly at night.

All pilots should check the weather and use good judgment in planning flights. The VFR pilot should use extra caution in avoiding low visibility conditions.

Motion sickness often precedes or accompanies disorientation and may further jeopardize the flight.

### STALLS, SPINS AND SLOW FLIGHT

Stalls, and slow flight, should be practiced at safe altitudes to allow for recovery. Either of these maneuvers should be performed at an altitude in excess of 6,000 feet above ground level.

Spins are prohibited in this airplane. Since spins are preceded by stalls, a prompt and decisive stall recovery protects against inadvertent spins.

### VORTICES — WAKE TURBULENCE

Every airplane generates wakes of turbulence while in flight. Part of this is from the propeller or jet engine and part from the wing tip vortices. The larger and heavier the airplane the more pronounced and turbulent the wakes will be. Wing tip vortices from large heavy airplanes are very severe at close range, degenerating with time, wind and space. These are rolling in nature from each wing tip. In test, vortex velocities of 133 knots have been recorded. Exhaust velocities from large airplanes at takeoff have been measured at 25 MPH, 2100 feet behind medium large airplanes.

Encountering the rolling effect of wing tip vortices within two minutes or less after passage of large airplanes is the most hazardous to the light airplanes. This roll effect can exceed the maximum counter roll obtainable in an airplane.

The turbulent areas may remain for as long as three minutes or more, depending on wind conditions, and may extend several miles behind the airplane. Plan to fly slightly above or to the side of the other airplanes.

Because of the wide variety of conditions that can be encountered, there is no set rule to follow to avoid wake turbulence in all situations, however, the Airman's Flight Information Manual goes into considerable detail for a number of vortex avoidance procedures. Use prudent judgment and allow ample clearance time and space following or crossing the wake of large airplanes and in all takeoff, climb out, approach and landing operations.

### TAKEOFF AND LANDING CONDITIONS

Use caution when landing on runways that are covered by water or slush which cause hydroplaning (aquaplaning), a phenomenon that renders braking and steering ineffective because of the lack of sufficient surface friction. Snow and ice covered runways are also hazardous. The pilot should also be alert to the possibility of the brakes freezing.

Use caution when taking off and landing during gusty wind conditions. Also be aware of the special wind conditions caused by buildings or other obstructions located near the runway in a crosswind pattern.

## MEDICAL FACTS FOR PILOTS

### GENERAL

Modern industry's record in providing reliable equipment is very good. When the pilot enters the airplane, he becomes an integral part of the man-machine system. He is just as essential to a successful flight as the control surfaces. To ignore the pilot in pre-flight planning would be as senseless as failing to inspect the integrity of the control surfaces or any other vital part of the machine. The pilot himself has the responsibility for determining his reliability prior to entering the airplane for flight.

When piloting an airplane, an individual should be free of conditions which are harmful to alertness, ability to make correct decisions, and rapid reaction time.

### FATIGUE

Fatigue generally slows reaction times and causes errors due to inattention. In addition to the most common cause of fatigue, insufficient rest and loss of sleep, the pressures of business, financial worries and family problems, can be important contributing factors. If your fatigue is marked prior to a given flight, don't fly. To prevent fatigue effects during long flights, keep mentally active by making ground checks and radio-navigation position plots.

### HYPOXIA

Hypoxia in simple terms is a lack of sufficient oxygen to keep the brain and other body tissues functioning properly. Wide individual variation occurs with respect to susceptibility to hypoxia. In addition to progressively insufficient oxygen at higher altitudes, anything interfering with the blood's ability to carry oxygen can contribute to hypoxia (anemias, carbon monoxide, and certain drugs). Also, alcohol and various drugs decrease the brain's tolerance to hypoxia.

Your body has no built in alarm system to let you know when you are not getting enough oxygen. It is impossible to predict when or where hypoxia will occur during a given flight, or how it will manifest itself. A major early symptom of hypoxia is an increased sense of well-being (referred to as euphoria). This progresses to slow reactions, impaired thinking ability, unusual fatigue, and dull headache feeling.



The symptoms are slow but progressive, insidious in onset, and are most marked at altitudes starting above ten thousand feet. Night vision, however, can be impaired starting at altitudes lower than 10,000 feet. Heavy smokers may experience early symptoms of hypoxia at altitudes lower than is so with non-smokers.

#### **HYPERVENTILATION**

Hyperventilation or overbreathing, is a disturbance of respiration that may occur in individuals as a result of emotional tension or anxiety. Under conditions of emotional stress, fright, or pain, breathing rate may increase, causing increased lung ventilation, although the carbon dioxide output of the body cells does not increase. As a result, carbon dioxide is "washed out" of the blood. The most common symptoms of hyperventilation are: dizziness; hot and cold sensations; tingling of the hands, legs and feet; tetany; nausea; sleepiness; and finally unconsciousness.

Should symptoms occur, consciously slow your breathing rate until symptoms clear and then resume normal breathing rate. Breathing can be slowed by breathing into a bag, or talking loud.

#### **ALCOHOL**

Common sense and scientific evidence dictate that you not fly as a crew member while under the influence of alcohol. Even small amounts of alcohol in the human system can adversely affect judgment and decision making abilities. FAR 91.11 states "(a) No person may act as a crew member — (1) within 8 hours after the consumption of any alcoholic beverage."

#### **DRUGS**

Self-medication or taking medicine in any form when you are flying can be extremely hazardous. Even simple home or over-the-counter remedies and drugs such as aspirin, antihistamines, cold tablets, cough mixtures, laxatives, tranquilizers, and appetite suppressors, may seriously impair the judgment and coordination needed while flying. The safest rule is to take no medicine before or while flying, except on the advice of your Aviation Medical Examiner.

#### **SCUBA DIVING**

Flying shortly after any prolonged scuba diving could be dangerous. Under the increased pressure of the water, excess nitrogen is absorbed into your system. If sufficient time has not elapsed prior to takeoff for your system to rid itself of this excess gas, you may experience the bends at altitudes under 10,000 feet, where most light planes fly.

**SECTION 10  
SAFETY INFORMATION**

**GULFSTREAM AMERICAN  
MODEL AA-5B TIGER**

**ADDITIONAL INFORMATION**

In addition to the coverage of subjects in this section, the National Transportation Safety Board and the Federal Aviation Administration periodically issue general aviation pamphlets concerning aviation safety, and in greater detail. These can be obtained at FAA Offices, Weather Stations, Flight Service Stations, or Airport Facilities. These are very good sources of information and are highly recommended for study. Some of these are titled:

Airman's Information Manual  
12 Golden Rules for Pilots  
Weather or Not  
Disorientation  
Plane Sense  
Weather Info Guide for Pilots  
Wake Turbulence  
Don't Trust to Luck, Trust to Safety  
Thunderstorm - TRW  
IFR VFR Either Way Disorientation Can Be Fatal

**NORMAL PROCEDURES  
CHECKLIST**

**PREFLIGHT INSPECTION**

1. **Cabin**  
Canopy – OPEN (turn handle counterclockwise to open.)  
Control Wheel Lock – REMOVE  
Ignition Switch – OFF  
Master Switch – OFF  
Mixture – IDLE CUTOFF
2. **Left Wing Trailing Edge**  
Flap – Secure and undamaged  
Aileron – freedom of movement
3. **Left Wing**  
Wing Tip and Light – Undamaged  
Aileron Counterweight Access – Unobstructed  
Wing Inspection Plates – Secure  
Tiedown – Removed  
Pitot Tube – Unobstructed  
Fuel Tank Vent – Unobstructed
4. **Left Wing Leading Edge**  
Fuel Tank – Full, cap seal checked for damage, cap secure  
Tank Drain – Fuel free of water and sediment, drain secure  
Sump Drain – Fuel free of water and sediment, drain secure  
Fuel – Proper color  
Landing Gear Wheel Fairing and Tire – Undamaged, tire properly inflated  
Chocks – Removed
5. **Left Cowl**  
Windshield – Clean, undamaged  
OAT Gauge – Secure, undamaged  
Fuel Pump Overflow Drain – Unobstructed  
Fresh Air Vents – Unobstructed  
Air Cleaner Drain – Unobstructed  
Oil Breather Vent – Unobstructed  
Cowling – Open, Secured  
Baffles – Secure, Undamaged  
Cowling – Closed, latches secured (flush with surface)
6. **Nose**  
Propeller and Spinner – Secure, undamaged  
Cowling – Secure, undamaged  
Landing Light – Secured, undamaged  
Nose Gear, and Fairing – Undamaged, tire properly inflated, mud scraper clear

**NORMAL PROCEDURES  
CHECKLISTS**

**GULFSTREAM AMERICAN  
MODEL AA-5B TIGER  
1977/1978**

- Tow Bar – Removed and stowed
- Chocks – Removed
- Engine Cooling Openings – Unobstructed
- 7. Right Cowl**
  - Cowl – Open
  - Engine Baffles – Unobstructed, undamaged
  - Carburetor Air Duct – Unobstructed
  - Engine Cooling Openings – Unobstructed
  - Engine Oil Level – 6 Quarts minimum, capacity 8 quarts
  - Engine Oil Dipstick – Secured (finger tight)
  - Vacuum Pump Vent – Unobstructed
  - Battery – Secure
  - Alternator Belt – Proper tension
  - Cowl – Closed, latches secured (flush with surface)
  - Windshield – Clean, undamaged
- 8. Right Wing Leading Edge**
  - Fuel Tank – Full, cap seal checked for damage, cap secured
  - Tank Drain – Fuel free of water and sediment, drain secured
  - Sump Drain – Fuel free of water and sediment, drain secure
  - Fuel – Proper color
  - Landing Gear, Wheel Fairing and Tire – Undamaged, tire properly inflated
  - Chocks – Removed
- 9. Right Wing**
  - Wing Tip and Light – Undamaged
  - Aileron Counterweight Access – Unobstructed
  - Wing Inspection Plates – Secured
  - Tiedown – Removed
  - Fuel Tank Vent – Unobstructed
- 10. Right Wing Trailing Edge**
  - Aileron – Freedom of movement
  - Flap – Secure and undamaged
- 11. Right Side of Fuselage**
  - Static Source – Unobstructed
  - Antennas – Secure, undamaged
  - Fuselage – Undamaged
- 12. Empennage**
  - Elevators – Freedom of movement
  - Rudder – Freedom of movement
  - Trim Tabs – Secure, undamaged
  - Tail Cone and Light – Secured, undamaged
  - Tie Down – Removed

13. **Left Side of Fuselage**  
Static Source — Unobstructed  
Fuselage — Undamaged  
Baggage Door — Secure
14. **Night Flight Preflight**  
Fuses and Circuit Breakers — Check  
Spare Fuses — In Map Compartment  
Flashlight — Aboard  
Required Charts — Aboard

#### ELECTRICAL SYSTEMS PREFLIGHT

1. **Cabin**  
Master Switch — ON  
Instrument Lights — Check Rheostat, OFF  
Navigation Lights — ON  
Flashing Beacon — ON  
Strobe Lights — ON  
Pitot Heat — ON  
Landing Light — ON
2. **Left Wing Tip**  
Navigation Light — Illuminated  
Strobe Light — Flashing  
Pitot Tube — Check for heat
3. **Nose**  
Landing Light — Illuminated
4. **Right Wing**  
Stall Warning Vane — Lift, check that stall warning horn sounds
5. **Right Wing Tip**  
Navigation Light — Illuminated  
Strobe Light — Flashing
6. **Empennage**  
Navigation Light — Illuminated  
Flashing Beacon — Operating
7. **Cabin**  
Master Switch — OFF  
Navigation Lights — OFF  
Flashing Beacon — OFF  
Strobe Lights — OFF  
Pitot Heat — OFF  
Landing Light — OFF

**NORMAL PROCEDURES  
CHECKLISTS**

**GULFSTREAM AMERICAN  
MODEL AA-5B TIGER  
1977/1978**

**BEFORE STARTING ENGINE**

Preflight Inspection — Complete  
Seats, Seat Belts and Shoulder Harness — Adjusted, locked  
Radios, Autopilot, Electrical Equipment — OFF  
Parking Brake — SET  
Controls — Check for proper operation

**STARTING ENGINE**

Master/Alternator Switch — ON  
Mixture — FULL RICH  
Carburetor Heat — OFF  
Fuel Selector Valve — Set to fullest tank  
Prime — As required  
Flaps — UP  
Auxiliary Fuel Pump — ON (Check pressure 0.6 — 8 PSI)  
Propeller — CLEAR  
Ignition Switch — ON LEFT  
Throttle — Open approximately 1/4 inch  
Starter Button — Press, release when engine starts  
Ignition Switch — ON BOTH  
Oil Pressure — Check, if no pressure within 30 seconds, shut down engine  
Engine — Warm up at 1000 to 1200 RPM  
Auxiliary Fuel Pump — OFF

**BEFORE TAKEOFF**

Parking Brake — SET  
Throttle — Set for 1800 RPM  
Engine Instruments — In green arc  
Ammeter — Charging  
Vacuum Gage — 4.6 to 5.4 in. Hg.  
Magnetos — Check, 175 RPM maximum drop, not over 50 RPM difference between left and right magnetos  
Carburetor Heat — ON, check for RPM drop, then set to OFF  
Throttle — Set 1000 RPM  
Radios — ON, checked, transponder — STANDBY  
Engine — Idles smoothly  
Engine is ready for takeoff when it will take throttle without hesitating or faltering and oil temperature is in green arc.  
Trim Tab — SET  
Flaps — Checked for operation, set UP  
Mixture — FULL RICH (or as required by field elevation)  
Throttle Friction Lock — ADJUSTED  
Auxiliary Fuel Pump — ON, check for pressure change, then set to OFF  
Flight Instruments — SET (clock, directional gyro, altimeter, radios)  
Lights — ON, as required  
Parking Brake — OFF

GULFSTREAM AMERICAN  
MODEL AA-5B TIGER  
1977/1978

NORMAL PROCEDURES  
CHECKLISTS

TAKEOFF

Normal Takeoff

Flaps — UP  
Carburetor Heat — OFF  
Auxiliary Fuel Pump — ON  
Throttle — FULL OPEN  
Elevator Control — Raise nosewheel at 50 KIAS (58 MPH) to 55 KIAS (62 MPH)  
Turn Transponder to ON after takeoff

Obstacle Clearance Takeoff

Flaps — UP  
Carburetor Heat — OFF  
Auxiliary Fuel Pump — ON  
Throttle — FULL OPEN  
Elevator — Apply light back pressure at 50 KIAS (58 MPH), lift nosewheel at 55 KIAS (62 MPH)  
Climb Speed — 65 KIAS (75 MPH)

CLIMB

Normal Climb Speed — 90 KIAS (104 MPH) at full throttle  
Beat Rate of Climb Speed — 90 KIAS (104 MPH) at sea level, full throttle  
Best Angle of Climb Speed — 70 KIAS (81 MPH) at sea level, full throttle

CRUISE

Auxiliary Fuel Pump — OFF  
Power — SET at 2200 to 2700 RPM  
Trim Tab — SET as required  
Mixture — SET as required. Full rich when operating at more than 75% power. If in doubt of percentage of power being used, use full rich mixture for operation below 5000 Ft.

DESCENT

Power — As required for descent  
Mixture — As required by altitude  
Carburetor Heat — As required by weather conditions  
Trim Tab — SET as required

BEFORE LANDING

Seats, Seat Belts and Shoulder Harness — Adjust and lock  
Fuel Selector — On fullest tank  
Mixture — FULL RICH  
Auxiliary Fuel Pump — ON

Revised: December 15, 1977

**NORMAL PROCEDURES  
CHECKLISTS**

**GULFSTREAM AMERICAN  
MODEL AA-5B TIGER  
1977/1978**

Carburetor Heat — ON if required  
Parking Brake — OFF  
Flaps — SET as required, below 103 KIAS (119 MPH)  
Airspeed — 65 KIAS (75 MPH) to 70 KIAS (80 MPH)  
Landing Light — ON as required

**BALKED LANDING**

Power — Full throttle  
Carburetor Heat — OFF  
Airspeed — 70 KIAS (80 MPH)  
Establish Climb Attitude  
Flaps — Retract slowly, maintain safe airspeed

**LANDING**

**Normal Landing**

Touch down on main gear  
Lower nosewheel slowly as speed decreases  
Use rudder to maintain directional control down to approximately 17  
KIAS (20 MPH)  
Brakes — Use as required for stopping and directional control.

**Obstacle Clearance Landings,**

Flaps — Fully extended below 103 KIAS (119 MPH)  
Airspeed — 63 KIAS (73 MPH)  
Touch down on main gear  
Elevator — Full up control  
Flaps — UP  
Brakes — As required for directional control and stopping.

**AFTER LANDING**

Flaps — UP  
Auxiliary Fuel Pump — OFF  
Landing Light — OFF (if used)  
Carburetor Heat — OFF  
Strobe Light — OFF (if used)

**SHUT-DOWN/SECURING AIRPLANE**

Electrical Equipment, Radios, Lights — OFF  
Mixture — IDLE CUTOFF  
Ignition — OFF (after propeller has stopped)  
Master Switch — OFF  
Control Lock — Installed  
Parking Brake — SET  
Chocks/Tiedowns — Installed  
Parking Brake — OFF

Revised: December 15, 1977