



Gulfstream Aerospace Corporation

MAINTENANCE MANUAL

MODELS:

AA-5 TRAVELER

AA-5A CHEETAH

AA-5B TIGER

ISSUED: NOV 15/1976

REVISION 4: JUNE 1, 1983

1st Reprint includes Basic thru Revision 4

2nd Reprint April 1987

GULFSTREAM AEROSPACE CORPORATION

P.O. BOX 2206

SAVANNAH, GEORGIA 31402

© 1983 Gulfstream Aerospace Corporation

© 1983 Gulfstream Aerospace Corporation
All rights reserved, including the right to reproduce this publication. No part may be reproduced, stored in any retrieval system, or transmitted in any part or form or by any means, electronic, photocopying, microfilm, microfiche, mechanical, or otherwise, without prior written permission of Gulfstream Aerospace Corporation.

**AA-5 SERIES
MAINTENANCE MANUAL**

LIST OF EFFECTIVE PAGES

| CHAPTER/ SECTION | PAGE | DATE | CHAPTER/ SECTION | PAGE | DATE |
|-------------------------------|--------------|-------------|-----------------------------|--------------|-------------|
| List of Effective Pages | *1 | June 1/83 | 9 | 1 | Nov 15/76 |
| | *2 | June 1/83 | 9-0 | 1 and 2 | July 15/78 |
| | *3 | June 1/83 | 9-1-1 | 1 | July 15/78 |
| | *4 | June 1/83 | 9-1-1 | 2 | Nov 15/76 |
| | *5 | June 1/83 | | | |
| | *6 | June 1/83 | 10 | 1 | July 15/78 |
| Record of Revisions | | | 10-0 | 1 | July 15/78 |
| | | | 10-1-1 | 1 | Nov 15/76 |
| | | | 11 | 1 | Dec 15/77 |
| Record of Temporary Revisions | | | 11-0 | 1 | Dec 15/77 |
| | | | 11-1-1 | 1 thru 4 | Dec 15/77 |
| | | | 11-2-1 | 1 thru 9 | Dec 15/77 |
| List of Chapters | 1 | July 15/78 | 12 | 1 and 2 | Nov 15/76 |
| | 2 | July 15/78 | 12-0 | 1 | Nov 15/76 |
| Introduction | | | 12-0 | 2 and 3 | Dec 15/77 |
| | 1 | Nov 15/76 | 12-0 | 4 | July 15/78 |
| | 2 | Nov 15/76 | 12-0 | 5 thru 7 | Dec 15/77 |
| | | | 12-0 | 8 thru 12 | Nov 15/76 |
| | | | 12-1-1 | 1 | July 15/78 |
| 5 | 1 | Nov 15/76 | 12-1-1 | 2 | Dec 15/77 |
| 5-0 | 1 | July 15/78 | 12-1-1 | 3 and 4 | July 15/78 |
| 5-1-1 | 1 | Dec 15/77 | 12-1-1 | 5 | Dec 15/77 |
| 5-2-1 | 1 | Nov 15/76 | 12-1-1 | 6 thru 8 | July 15/78 |
| 5-2-1 | 2 | Dec 15/77 | 12-2-1 | 1 thru 11 | July 15/78 |
| 5-2-1 | 3 | Jan 4/80 | 12-2-1 | 12 | Nov 15/76 |
| 5-2-1 | 4 | Dec 15/77 | 12-2-1 | 13 | July 15/78 |
| 5-2-1 | 5 | Jan 4/80 | 12-3-1 | 1 thru 3 | Jan 4/80 |
| 5-2-1 | 6 | Dec 15/77 | | | |
| 5-2-1 | 201 and 202 | Jan 4/80 | 20 | 1 | July 15/78 |
| 5-2-1 | 203 | Nov 15/76 | 20* | 2 | June 1/83 |
| 5-2-1 | 204 | Jan 4/80 | 20-1-0 | 1 | Dec 15/77 |
| 5-2-1 | 205 thru 214 | Nov 15/76 | 20-1-0 | 2 and 3 | Nov 15/76 |
| 5-5-1 | 1 | July 15/78 | 20-1-0 | 4 | July 15/78 |
| 5-5-1 | 201 thru 204 | Nov 15/76 | 20-1-0 | 5 | Nov 15/76 |
| 5-5-1 | 205 | July 15/78 | 20-1-0 | 6 | July 15/78 |
| | | | 20-1-0 | 801 | July 15/78 |
| 6 | 1 | Nov 15/76 | 20-1-0 | 802 and 803 | Nov 15/76 |
| 6-0 | 1 thru 3 | Nov 15/76 | 20-1-0 | 804 | July 15/78 |
| 6-1-1 | 1 thru 3 | July 15/78 | 20-1-0 | 805 thru 807 | Nov 15/76 |
| 6-2-1 | 1 | July 15/78 | 20-1-0 | 808 thru 810 | Jan 4/80 |
| 6-2-1 | 2 | Dec 15/77 | 20-1-0 | 811 thru 825 | Nov 15/76 |
| | | | 20-1-0 | 826 thru 827 | Jan 4/80 |
| 7 | 1 | Nov 15/76 | 20-1-0 | 828 | July 15/78 |
| 7-0 | 1 | Nov 15/76 | 20-1-0* | 829 and 830 | June 1/83 |
| 7-0 | 2 | July 15/78 | 20-2-0 | 1 | Nov 15/76 |
| 7-1-1 | 1 and 2 | July 15/78 | 20-2-0 | 701 | Dec 15/77 |
| | | | 20-2-0 | 702 and 703 | Nov 15/76 |
| 8 | 1 | Dec 15/77 | 20-2-0 | 704 | July 15/78 |
| 8-0 | 1 | Dec 15/77 | | | |
| 8-1-1 | 1 | July 15/78 | 21 | 1 | Nov 15/76 |
| 8-2-1 | 1 and 2 | July 15/78 | 21-0 | 1 | Nov 15/76 |
| 8-3-1 | 1 | July 15/78 | 21-2-1 | 1 | Nov 15/76 |
| 8-4-1 | 1 | July 15/78 | 21-2-1 | 2 and 3 | July 15/78 |

* Pages changed or added by the current revision.

**AA-5 SERIES
MAINTENANCE MANUAL**

LIST OF EFFECTIVE PAGES

| CHAPTER/ SECTION | PAGE | DATE | CHAPTER/ SECTION | PAGE | DATE |
|-----------------------------|--------------|-------------|-----------------------------|--------------|-------------|
| 21-4-1 | 1 | Nov 15/76 | 23-7-0 | 101 | Dec 15/77 |
| 21-4-1 | 101 | July 15/78 | 23-7-0 | 201 thru 203 | Nov 15/76 |
| 21-4-1 | 201 thru 205 | Dec 15/77 | 23-7-0 | 204 | July 15/78 |
| 22 | 1 | July 15/78 | 24 | 1 and 2 | July 15/78 |
| 22-0 | 1 | Nov 15/76 | 24-0 | 1 | July 15/78 |
| 22-1-1 | 1 thru 6 | Nov 15/76 | 24-0-1 | 1 thru 5 | Dec 15/77 |
| 22-1-1 | 7 | July 15/78 | 24-0-1 | 6 | July 15/78 |
| 22-1-1 | 201 | July 15/78 | 24-0-1 | 7 | Dec 15/77 |
| | | | 24-0-1 | 201 | Dec 15/77 |
| 23 | 1 thru 3 | Dec 15/77 | 24-3-0 | 1 and 2 | July 15/78 |
| 23-0 | 1 | Nov 15/76 | 24-3-0 | 3 and 4 | Dec 15/77 |
| 23-2-1 | 1 | Dec 15/77 | 24-3-1 | 1 thru 4 | July 15/78 |
| 23-2-1 | 2 | Nov 15/76 | 24-3-1 | 101 | July 15/78 |
| 23-2-1 | 2A thru 4 | Dec 15/77 | 24-3-1 | 102 | Dec 15/77 |
| 23-2-1 | 101 | Nov 15/76 | 24-3-1 | 201 and 202 | Dec 15/77 |
| 23-2-1 | 201 | July 15/78 | 24-3-1 | 203 and 204 | July 15/78 |
| 23-2-1 | 202 | Nov 15/76 | 24-3-2 | 1 | Dec 15/77 |
| 23-2-1 | 203 | July 15/78 | 24-3-2 | 2 and 3 | July 15/78 |
| 23-2-1 | 204 | Nov 15/76 | 24-3-2 | 4 thru 6 | Dec 15/77 |
| 23-2-1 | 205 | Dec 15/77 | 24-3-2 | 101 thru 103 | Dec 15/77 |
| 23-2-2 | 1 | Dec 15/77 | 24-3-2 | 201 thru 203 | Dec 15/77 |
| 23-2-2 | 2 | Nov 15/76 | 24-4-1 | 1 | Dec 15/77 |
| 23-2-2 | 101 | Nov 15/76 | 24-4-1 | 201 | Dec 15/77 |
| 23-2-2 | 201 | Dec 15/77 | 24-4-1 | 202 | July 15/78 |
| 23-2-2 | 202 | Nov 15/76 | | | |
| 23-2-3 | 1 thru 3 | Dec 15/77 | 25 | 1 and 2 | July 15/78 |
| 23-2-3 | 101 | Dec 15/77 | 25 | 3 | Dec 15/77 |
| 23-2-3 | 201 and 202 | Dec 15/77 | 25-1-0 | 1 and 2 | July 15/78 |
| 23-5-0 | 1 | Dec 15/77 | 25-1-0 | 3 | Dec 15/77 |
| 23-5-0 | 101 | Nov 15/76 | 25-1-0 | 201 and 202 | July 15/78 |
| 23-5-0 | 201 | Nov 15/76 | 25-2-0 | 1 and 2 | July 15/78 |
| 23-5-1 | 1 | Dec 15/77 | 25-2-0 | 201 and 202 | July 15/78 |
| 23-5-1 | 2 | Nov 15/76 | 25-3-0 | 1 | Nov 15/76 |
| 23-5-1 | 3 | July 15/78 | 25-3-0 | 201 | July 15/78 |
| 23-5-1 | 4 and 5 | Dec 15/77 | 25-4-0 | 1 and 2 | Nov 15/76 |
| 23-5-1 | 101 | Nov 15/76 | 25-4-0 | 201 and 202 | July 15/78 |
| 23-5-1 | 201 | Dec 15/77 | 25-5-0 | 1 | Nov 15/76 |
| 23-5-1 | 202 | Nov 15/76 | 25-5-0 | 2 | Dec 15/77 |
| 23-5-2 | 1 thru 3 | Nov 15/76 | 25-5-0 | 201 and 202 | July 15/78 |
| 23-5-2 | 4 | Dec 15/77 | 25-6-0 | 1 | Nov 15/76 |
| 23-5-2 | 101 | Nov 15/76 | 25-6-0 | 2 | July 15/78 |
| 23-5-2 | 201 | Nov 15/76 | 25-7-0* | 201 | Jan 4/80 |
| 23-5-3 | 1 thru 4 | Dec 15/77 | | | |
| 23-5-3 | 101 | Dec 15/77 | 27 | 1 thru 3 | Jan 4/80 |
| 23-5-3 | 201 | Dec 15/77 | 27 | 4 | July 15/78 |
| 23-7-0 | 1 | Dec 15/77 | 27-0 | 1 | Nov 15/76 |
| | | | 27-1-1 | 1 and 2 | Nov 15/76 |

* Pages changed or added by the current revision

**AA-5 SERIES
MAINTENANCE MANUAL**

LIST OF EFFECTIVE PAGES

| CHAPTER/ SECTION | PAGE | DATE | CHAPTER/ SECTION | PAGE | DATE |
|-----------------------------|--------------|-------------|-----------------------------|--------------|-------------|
| 27-1-1 | 3 | July 15/78 | 27-3-1 | 506 and 507 | July 15/78 |
| 27-1-1 | 301 | July 15/78 | 27-3-1 | 508 and 509 | Jan 4/80 |
| 27-1-1 | 401 | Jan 4/80 | 27-3-1 | 510 | Jan 4/80 |
| 27-1-1 | 402 | Jan 4/80 | 27-3-1 | 511 | Jan 4/80 |
| 27-1-1 | 403 and 404 | July 15/78 | 27-3-1 | 701 | July 15/78 |
| 27-1-1 | 405 | Dec 15/77 | 27-5-1 | 1 thru 6 | Nov 15/76 |
| 27-1-1 | 406 | July 15/78 | 27-5-1 | 101 and 102 | July 15/78 |
| 27-1-1 | 407 | Dec 15/77 | 27-5-1 | 301 | July 15/78 |
| 27-1-1 | 408 | July 15/78 | 27-5-1 | 401 | July 15/78 |
| 27-1-1 | 409 | Dec 15/77 | 27-5-2 | 402 | Dec 15/77 |
| 27-1-1 | 410 | July 15/78 | 27-5-1 | 403 thru 405 | July 15/78 |
| 27-1-1 | 411 | Dec 15/77 | 27-5-1 | 501 and 502 | July 15/78 |
| 27-1-1 | 412 | July 15/78 | 27-5-1 | 701 | Jan 4/80 |
| 27-1-1 | 413 | Jan 4/80 | 27-7-1 | 1 | Nov 15/76 |
| 27-1-1 | 501 thru 506 | Jan 4/80 | 27-8-1 | 1 | July 15/78 |
| 27-1-1 | 507 thru 510 | Jan 4/80 | 27-8-1 | 2 | Nov 15/76 |
| 27-1-1 | 701 | Nov 15/76 | 27-8-1 | 101 | July 15/78 |
| 27-2-1 | 1 and 2 | Nov 15/76 | 27-8-1 | 401 | July 15/78 |
| 27-2-1 | 301 | July 15/78 | 27-8-1 | 402 | Dec 15/77 |
| 27-2-1 | 401 | July 15/78 | 27-8-1 | 501 | July 15/78 |
| 27-2-1 | 402 | Jan 4/80 | | | |
| 27-2-1 | 403 | July 15/78 | 28 | 1 | Dec 15/77 |
| 27-2-1 | 404 | Dec 15/77 | 28 | 2 | July 15/78 |
| 27-2-1 | 405 | July 15/78 | 28-0 | 1 thru 4 | Dec 15/77 |
| 27-2-1 | 406 | Dec 15/77 | 28-0 | 101 and 102 | Dec 15/77 |
| 27-2-1 | 407 | Jan 4/80 | 28-0 | 201 thru 203 | Dec 15/77 |
| 27-2-1 | 501 | July 15/78 | 28-0 | 204 | July 15/78 |
| 27-2-1 | 502 and 503 | Nov 15/76 | 28-1-1 | 1 | July 15/78 |
| 27-2-1 | 504 | Dec 15/77 | 28-1-1 | 501 | Dec 15/77 |
| 27-2-1 | 505 | Jan 4/80 | 28-1-1 | 601 | Dec 15/77 |
| 27-2-1 | 701 | Nov 15/76 | 28-1-1* | 801 and 802 | June 1/83 |
| 27-3-1 | 1 thru 3 | Nov 15/76 | 28-1-1 | 803 and 804 | Dec 15/77 |
| 27-3-1 | 4 | July 15/78 | 28-1-1* | 805 thru 807 | June 1/83 |
| 27-3-1 | 301 | July 15/78 | 28-2-1 | 1 | Dec 15/77 |
| 27-3-1 | 401 | Jan 4/80 | 28-2-1 | 201 | July 15/78 |
| 27-3-1 | 402 | Dec 15/77 | 28-2-1 | 202 | Jan 4/80 |
| 27-3-1 | 403 and 404 | Jan 4/80 | 28-2-1 | 401 thru 403 | Jan 4/80 |
| 27-3-1 | 405 | Dec 15/77 | 28-2-1 | 404 | Dec 15/77 |
| 27-3-1 | 406 and 407 | July 15/78 | 28-2-1 | 405 | July 15/78 |
| 27-3-1 | 408 | Dec 15/77 | 28-2-1 | 501 | July 15/78 |
| 27-3-1 | 409 and 410 | July 15/78 | 28-2-1 | 502 | Dec 15/77 |
| 27-3-1 | 411 | Dec 15/77 | 28-2-1 | 801 | July 15/78 |
| 27-3-1 | 412 | July 15/78 | 28-3-1 | 1 | Dec 15/77 |
| 27-3-1 | 413 thru 415 | Jan 4/80 | 28-3-1 | 101 | Dec 15/77 |
| 27-3-1 | 501 | July 15/78 | 28-3-1 | 401 | July 15/78 |
| 27-3-1 | 502 | Nov 15/76 | 28-3-1 | 402 | Dec 15/77 |
| 27-3-1 | 503 and 504 | July 15/78 | 28-3-1 | 403 | July 15/78 |
| 27-3-1 | 505 | Nov 15/76 | 28-3-1 | 501 | July 15/78 |
| | | | 28-3-1 | 502 | Dec 15/77 |

*Pages changed or added by the current revision

**AA-5 SERIES
MAINTENANCE MANUAL**

LIST OF EFFECTIVE PAGES

| CHAPTER/ SECTION | PAGE | DATE | CHAPTER/ SECTION | PAGE | DATE |
|-----------------------------|--------------|-------------|-----------------------------|--------------|-------------|
| 30 | 1 | July 15/78 | 34-1-3 | 1 | Nov 15/76 |
| 30 | 2 | Dec 15/77 | 34-1-3 | 101 | July 15/78 |
| 30-0 | 1 | Nov 15/76 | 34-1-3 | 201 | Nov 15/76 |
| 30-1-1 | 1 and 2 | Dec 15/77 | 34-1-4 | 1 | July 15/78 |
| 30-1-1 | 3 and 4 | July 15/78 | 34-1-4 | 101 | July 15/78 |
| 30-1-1 | 201 | July 15/78 | 34-1-4 | 201 | Nov 15/76 |
| 30-1-2 | 1 | Dec 15/77 | 34-1-5 | 1 | July 15/78 |
| 30-1-2 | 101 | Dec 15/77 | 34-1-5 | 101 | July 15/78 |
| 30-1-2 | 201 and 202 | July 15/78 | 34-1-5 | 201 | Nov 15/76 |
| 30-1-3 | 1 | Dec 15/77 | 34-2-1 | 1 | July 15/78 |
| 30-3-1 | 1 and 2 | Nov 15/76 | 34-2-1 | 101 | July 15/78 |
| 30-3-1 | 101 | July 15/78 | 34-2-1 | 201 | Nov 15/76 |
| 30-3-1 | 201 | Nov 15/76 | 34-2-2 | 1 | July 15/78 |
| 30-4-1 | 1 | Nov 15/76 | 34-2-2 | 101 | July 15/78 |
| 30-4-1 | 2 thru 5 | Dec 15/77 | 34-2-2 | 201 | Nov 15/76 |
| | | | 34-2-3 | 1 | July 15/78 |
| 32 | 1 and 2 | Nov 15/76 | 34-2-3 | 101 | July 15/78 |
| 32-0 | 1 | Nov 15/76 | 34-2-3 | 201 | Nov 15/76 |
| 32-1-1 | 1 | Nov 15/76 | 34-2-4 | 1 | July 15/78 |
| 32-1-1 | 201 thru 204 | Nov 15/76 | 34-2-4 | 101 | July 15/78 |
| 32-2-1 | 1 | Dec 15/77 | 34-2-4 | 201 | Nov 15/76 |
| 32-2-1 | 201 | Dec 15/77 | 34-5-1 | 1 | Dec 15/77 |
| 32-2-1 | 202 and 203 | Nov 15/76 | 34-5-1 | 2 | Nov 15/76 |
| 32-2-1 | 204 | July 15/78 | 34-5-1 | 3 | Dec 15/77 |
| 32-2-1* | 205 thru 209 | June 1/83 | 34-5-1 | 201 | July 15/78 |
| 32-4-1 | 1 | Dec 15/77 | 34-5-1 | 202 | Nov 15/76 |
| 32-4-1 | 201 thru 210 | Nov 15/76 | 34-5-2 | 1 thru 3 | Dec 15/77 |
| 32-4-2 | 1 thru 3 | Dec 15/77 | 34-5-2 | 201 | Dec 15/77 |
| 32-4-2 | 201 and 202 | Nov 15/76 | 34-5-2 | 202 | July 15/78 |
| 32-4-2 | 203 | July 15/78 | 34-5-3 | 1 | July 15/78 |
| 32-4-2 | 204 thru 207 | Nov 15/76 | 34-5-3 | 2 | Nov 15/76 |
| 32-4-2 | 208 | July 15/78 | 34-5-3 | 201 | Nov 15/76 |
| 32-4-2 | 209 | Dec 15/77 | 34-5-4 | 1 thru 10 | Dec 15/77 |
| 32-4-2 | 210 | Nov 15/76 | 34-5-4 | 201 | Nov 15/76 |
| 32-4-2 | 211 | July 15/78 | 34-5-4 | 202 | July 15/78 |
| | | | | | |
| 33 | 1 | July 15/78 | 37 | 1 | July 15/78 |
| 33-0 | 1 | Nov 15/76 | 37-0 | 1 | Nov 15/76 |
| 33-1-1 | 1 thru 3 | Nov 15/76 | 37-0 | 101 | Nov 15/76 |
| 33-1-1 | 201 and 202 | Nov 15/76 | 37-0 | 201 | July 15/78 |
| 33-4-1 | 1 and 2 | July 15/78 | 37-1-1 | 1 | July 15/78 |
| 33-4-1 | 3 | Nov 15/76 | 37-1-1 | 201 thru 203 | July 15/78 |
| 33-4-1 | 4 and 5 | July 15/78 | 37-2-1 | 1 | July 15/78 |
| 33-4-1 | 6 | Nov 15/76 | 37-2-1 | 201 | July 15/78 |
| 33-4-1 | 101 | Nov 15/76 | | | |
| 33-4-1 | 201 thru 205 | July 15/78 | 52 | 1 | July 15/78 |
| | | | 52-0 | 1 | Dec 15/77 |
| 34 | 1 and 2 | July 15/78 | 52-1-1 | 1 | Nov 15/76 |
| 34 | 3 and 4 | Dec 15/77 | 52-1-1 | 201 | July 15/78 |
| 34-0 | 1 | Nov 15/76 | 52-1-1 | 202 | Dec 15/77 |
| 34-1-1 | 1 | Nov 15/76 | 52-1-1 | 203 and 204 | July 15/78 |
| 34-1-1 | 2 | July 15/78 | 52-1-1 | 205 | Dec 15/77 |
| 34-1-1 | 101 | July 15/78 | 52-1-1 | 206 thru 208 | July 15/78 |
| 34-1-1 | 201 thru 203 | Nov 15/76 | 52-2-1 | 1 | Nov 15/76 |
| 34-1-2 | 1 | Nov 15/76 | 52-2-1 | 201 | July 15/78 |
| 34-1-2 | 201 | July 15/78 | | | |

* Pages changed or added by the current revision

**AA-5 SERIES
MAINTENANCE MANUAL**

LIST OF EFFECTIVE PAGES

| CHAPTER/ SECTION | PAGE | DATE | CHAPTER/ SECTION | PAGE | DATE |
|-----------------------------|--------------|-------------|-----------------------------|--------------|-------------|
| 52-2-1 | 202 and 203 | Dec 15/77 | 71-1-1 | 1 | Nov 15/76 |
| 52-2-1 | 204 | July 15/78 | 71-1-1 | 201 | July 15/78 |
| 52-2-1 | 205 | Nov 15/76 | 71-1-1 | 202 | Nov 15/76 |
| | | | 71-1-1 | 203 | July 15/78 |
| 53 | 1 | July 15/78 | 71-1-1 | 204 | Nov 15/76 |
| 53-0 | 1 | Dec 15/77 | 71-2-1 | 1 | Nov 15/76 |
| 53-0 | 2 and 3 | Nov 15/76 | 71-2-1 | 201 | Nov 15/76 |
| 53-0 | 201 thru 207 | July 15/78 | 71-2-1 | 202 and 203 | July 15/78 |
| | | | 71-6-1 | 1 and 2 | Nov 15/76 |
| 55 | 1 | July 15/78 | 71-6-2 | 1 | Nov 15/76 |
| 55-0 | 1 | Nov 15/76 | 71-6-2 | 201 | Nov 15/76 |
| 55-1-1 | 1 and 2 | Nov 15/76 | 71-6-2 | 202 and 203 | July 15/78 |
| 55-1-1 | 201 | Nov 15/76 | 71-7-1 | 1 | Nov 15/76 |
| 55-1-1 | 202 | Dec 15/77 | | | |
| 55-1-1 | 203 | Nov 15/76 | 73 | 1 and 2 | Nov 15/76 |
| 55-1-1 | 204 | Dec 15/77 | 73-0 | 1 | Nov 15/76 |
| 55-1-1 | 205 | Nov 15/76 | 73-1-1 | 1 | July 15/78 |
| 55-2-1 | 1 | Nov 15/76 | 73-1-1 | 201 thru 204 | Nov 15/76 |
| 55-2-1 | 201 | Nov 15/76 | 73-1-1 | 205 and 206 | July 15/78 |
| 55-2-1 | 202 | Dec 15/77 | 73-1-2 | 1 | Nov 15/76 |
| | | | 73-1-2 | 201 thru 203 | Nov 15/76 |
| 56 | 1 | July 15/78 | 73-1-3 | 1 | Nov 15/76 |
| 56-0 | 1 | July 15/78 | 73-1-3 | 201 thru 203 | Nov 15/76 |
| 56-0 | 201 and 202 | Dec 15/77 | 73-2-1 | 1 | Nov 15/76 |
| 56-0 | 203 | July 15/78 | 73-2-1 | 201 | July 15/78 |
| | | | 73-2-1 | 202 | Nov 15/76 |
| 57 | 1 | Jan 4/80 | 73-2-1 | 203 and 204 | July 15/78 |
| 57-0 | 1 | Nov 15/76 | 73-2-1 | 205 | Nov 15/76 |
| 57-0 | 201 | July 15/78 | 73-2-2 | 1 | Nov 15/76 |
| 57-0 | 202 | Nov 15/76 | 73-2-2 | 201 | Nov 15/76 |
| 57-0 | 203 thru 208 | July 15/78 | 73-2-2 | 202 | July 15/78 |
| 57-0 | 209 and 210 | Jan 4/80 | 73-2-2 | 203 | Nov 15/76 |
| | | | 73-2-2 | 204 | July 15/78 |
| 61 | 1 | Jan 4/80 | 73-3-1 | 1 | Nov 15/76 |
| 61-0* | 1 | June 1/83 | 73-3-1 | 201 and 202 | Nov 15/76 |
| 61-1-1 | 1 | July 15/78 | | | |
| 61-1-1 | 201 thru 207 | Jan 4/80 | 74 | 1 | Nov 15/76 |
| | | | 74-0 | 1 | Nov 15/76 |
| 71 | 1 and 2 | July 15/78 | 74-0 | 201 | Nov 15/76 |
| 71-0 | 1 | Nov 15/76 | 74-0 | 202 | Dec 15/77 |
| 71-0 | 101 thru 104 | Nov 15/76 | 74-0 | 203 | Nov 15/76 |
| 71-0 | 201 | Nov 15/76 | 74-0 | 204 and 205 | Dec 15/77 |
| 71-0 | 202 | July 15/78 | 74-0 | 206 | Nov 15/76 |

* Pages added or revised by the current revision

**AA-5 SERIES
MAINTENANCE MANUAL**

LIST OF EFFECTIVE PAGES

| CHAPTER// SECTION | PAGE | DATE |
|------------------------------|--------------|-------------|
| 77 | 1 | Dec 15/77 |
| 77-0 | 1 | Nov 15/76 |
| 77-1-1 | 1 | Nov 15/76 |
| 77-1-1 | 201 and 202 | Nov 15/76 |
| 78 | 1 | Nov 15/76 |
| 78-0 | 1 | Dec 15/77 |
| 78-0 | 201 thru 203 | Nov 15/76 |
| 78-0 | 204 and 205 | Jan 4/80 |
| 79 | 1 | Nov 15/76 |
| 79-0 | 1 | Nov 15/76 |
| 79-0 | 101 | Nov 15/76 |
| 79-0 | 201 | Nov 15/76 |
| 79-0 | 202 | Dec 15/77 |
| 79-0 | 203 and 204 | Nov 15/76 |
| 80 | 1 | Dec 15/77 |
| 80-1-1 | 1 | July 15/78 |
| 80-1-1 | 2 | Nov 15/76 |
| 80-1-1 | 101 | Dec 15/77 |
| 80-1-1 | 201 | Nov 15/76 |
| 80-1-1 | 202 and 203 | July 15/78 |
| 91 | 1 | Nov 15/76 |
| 91-0 | 1 and 2 | Nov 15/76 |

* Pages added or revised by the current revision

AA-5 SERIES
MAINTENANCE MANUAL

LIST OF CHAPTERS

| <u>TITLE</u> | <u>CHAPTER NO.</u> |
|-------------------------------|--------------------|
| <u>AIRCRAFT GENERAL</u> | |
| Time Limits/Maintenance Check | 5 |
| Dimensions and Areas | 6 |
| Lifting and Shoring | 7 |
| Leveling and Weighing | 8 |
| Towing and Taxiing | 9 |
| Parking and Mooring | 10 |
| Placards and Markings | 11 |
| Servicing | 12 |
| <u>AIRFRAME SYSTEMS</u> | |
| Standard Practices — Airframe | 20 |
| Air Conditioning | 21 |
| Auto Flight | 22 |
| Communications | 23 |
| Electrical Power | 24 |
| Equipment/Furnishings | 25 |
| Flight Controls | 27 |
| Fuel | 28 |
| Ice and Rain Protection | 30 |
| Landing Gear | 32 |
| Lights | 33 |
| Navigation | 34 |
| Vacuum | 37 |
| <u>STRUCTURE</u> | |
| Doors | 52 |
| Fuselage | 53 |
| Stabilizers | 55 |
| Windows | 56 |

AA-5 SERIES
MAINTENANCE MANUAL

LIST OF CHAPTERS

| <u>TITLE</u> | <u>CHAPTER NO.</u> |
|-------------------------|--------------------|
| Wings | 57 |
| <u>PROPELLER</u> | |
| Propellers | 61 |
| <u>POWER PLANT</u> | |
| Power Plant General | 71 |
| Engine Fuel and Control | 73 |
| Ignition | 74 |
| Engine Indicating | 77 |
| Exhaust | 78 |
| Oil | 79 |
| Starting | 80 |
| <u>CHARTS</u> | |
| Charts | 91 |

AA-5 SERIES
MAINTENANCE MANUAL

INTRODUCTION

GENERAL

The function of this Maintenance Manual is to acquaint maintenance personnel with the systems and their components of the AA-5, AA-5A and AA-5B aircraft and to direct them in the proper procedures for maintaining the aircraft in an airworthy condition.

This manual contains information on installations made in the aircraft during manufacture and optional equipment only. However, information derived from applicable Single Engine Aircraft Service Kits, Service Bulletins, and Service Letters will be included in the manual as soon as possible after the issuance of these documents. Changes or installations made by the operator are not included in this manual.

The ability of maintenance personnel is recognized, and those procedures which are considered common to all aircraft have been either briefly referenced or omitted.

FORMAT

The chapter identification in this manual has been prepared in accordance with Air Transport Association (ATA) Specification No. 100. A functional breakdown is employed whereby all data pertaining to a given system, or component of a system, may be found in one chapter with a minimum of cross-referencing to other chapters.

The Electrical Power Chapter in this manual covers only the power sources and distribution equipment for the electrical system. There is not a chapter in this manual specifically designated for instruments. Details of individual branch electrical or instrument systems will be found in the applicable chapter.

IDENTIFICATION OF SUBJECT MATTER

A three-dash number system is employed to identify subject matter. The first dash number identifies the chapter, the second dash number the section, and the third dash number the component or sub-section of the section. The following example illustrates how the numbering system is used in the NAVIGATION Chapter.

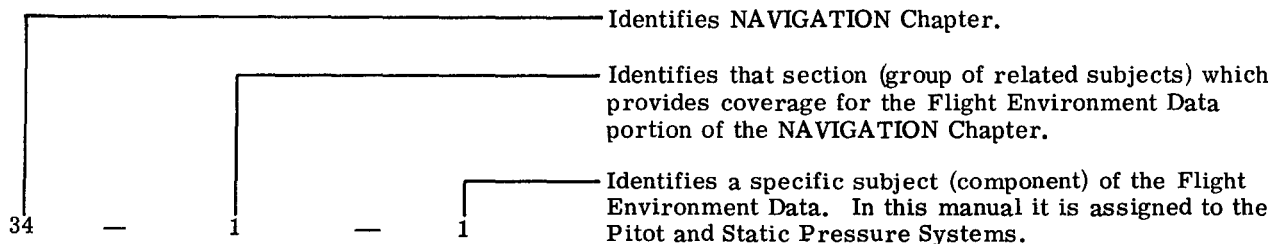

The dash 0 (-0) is provided as a means for covering a complete system or sub-system. The chapter number followed by a zero (34-0) will segregate that material covering the complete system; the chapter section numbers followed by a zero (34-1-0) is used for further details covering the sub-system or component.

PAGE NUMBER IDENTIFICATION

Page number blocks are used to separate the subject matter into the following categories:

| | |
|---------------------------------------|-----------------------|
| General Coverage and Unit Description | Pages 1 through 100 |
| Troubleshooting | Pages 101 through 200 |
| Maintenance Practices | (See Below) |

**AA-5 SERIES
MAINTENANCE MANUAL**

Maintenance Practices include as applicable the following sub-topics: Servicing, Removal/Installation, Adjustment/Test, Inspection/Check, Cleaning/Painting, and Approved Repairs.

If all sub-topics, under Maintenance Practices are brief, they are combined into one topic. All such combined topics are numbered within page number block 201-300. Whenever individual sub-topics are so lengthy that a combination requires several pages, each sub-topic is treated as an individual topic. Page number blocks for this sub-topic arrangement are as follows:

| | |
|----------------------|-----------|
| Servicing | 301 - 400 |
| Removal/Installation | 401 - 500 |
| Adjustment/Test | 501 - 600 |
| Inspection/Check | 601 - 700 |
| Cleaning/Painting | 701 - 800 |
| Approved Repairs | 801 - 900 |

Each new subject starts with page 1, 101, 201, etc. , and continues through the page block assignment to the extent necessary. The first page of each block is placed on a right-hand page.

FIGURE IDENTIFICATION

Figures (illustrations) are numbered consecutively within each topic (subject) as follows:

| | |
|------------------------------------|---------------------|
| Figures in Description - | 1, 2, 3, 4, 5, etc. |
| Figures in Troubleshooting - | 101, 102, 103, etc. |
| Figures in Maintenance Practices - | |
| When not sub-divided - | 201, 202, 203, etc. |
| When sub-divided - | |
| Servicing - | 301, 302, 303, etc. |
| Removal/Installation - | 401, 402, 403, etc. |
| Adjustment/Test - | 501, 502, 503, etc. |
| Cleaning/Painting - | 701, 702, 703, etc. |
| Approved Repairs - | 801, 802, 803, etc. |

INDEXING

Each chapter is prefaced with a table of contents identifying the subject matter within the chapter in the order of presentation. The table of contents is arranged with the following headings: DESCRIPTION; TROUBLESHOOTING; and MAINTENANCE PRACTICES.

PART NUMBERS

This manual must not be used for identifying spare parts by number. Consult the Illustrated Parts Catalog for this information. Part numbers are used in this manual only as a means of identification when nomenclature alone is inadequate.

**AA-5 SERIES
MAINTENANCE MANUAL**

REVISIONS

Revisions to the original text are indicated by vertical lines in the left margin of the page, adjacent to the revised material.

The manual is provided with a "Record of Revisions" page for recording revisions by number and the dates on which they were inserted in the manual.

Each page revised or added to the initial manual will be identified by the date of revision at the bottom of the page. Pages issued with the original manual are identified with the issue date of the manual.

Each revision also contains a "List of Effective Pages". This list contains the chapter, page number, and date of each page which is effective since the issuance of the initial manual. This list is updated for each revision, with page changes indicated by the number of asterisks (*) placed adjacent to the page number as noted below:

- *Pages revised by the current revision.
- **Pages added by the current revision.
- ***Pages deleted by the current revision.

CROSS REFERENCE

NAME, MODEL DESIGNATION AND EFFECTIVE SERIAL RANGES

Gulfstream American aircraft are certified under model number designations. For marketing purposes, each model is also given a name. The aircraft model number is used in this publication except where the name is necessary to differentiate between versions of the same basic model. The following table contains a listing of name, model years, model number, and serial range.

| POPULAR NAME | MODEL YEAR | MODEL | SERIAL NOS. | |
|------------------|------------|-------|-------------|-----------|
| | | | BEGINNING | ENDING |
| AA-5 or Traveler | 1972 | AA-5 | AA5-0001 | AA5-0154 |
| AA-5 or Traveler | 1973 | AA-5 | AA5-0155 | AA5-0405 |
| AA-5 or Traveler | 1974 | AA-5 | AA5-0406 | AA5-0640 |
| AA-5 or Traveler | 1975 | AA-5 | AA5-0641 | AA5-0834 |
| AA-5A or Cheetah | 1976 | AA-5A | AA5A-0001 | AA5A-0282 |
| AA-5A or Cheetah | 1977 | AA-5A | AA5A-0283 | AA5A-0522 |
| AA-5A or Cheetah | 1978 | AA-5A | AA5A-0523 | AA5A-0670 |
| AA-5A or Cheetah | 1979 | AA-5A | AA5A-0671 | AA5A-0900 |
| AA-5B or Tiger | 1975 | AA-5B | AA5B-0001 | AA5B-0110 |
| AA-5B or Tiger | 1976 | AA-5B | AA5B-0111 | AA5B-0399 |
| AA-5B or Tiger | 1977 | AA-5B | AA5B-0400 | AA5B-0692 |
| AA-5B or Tiger | 1978 | AA-5B | AA5B-0693 | AA5B-0905 |
| AA-5B or Tiger | 1979 | AA-5B | AA5B-0906 | AA5B-1323 |

**AA-5 SERIES
MAINTENANCE MANUAL**

CHAPTER 5

TIME LIMITS - MAINTENANCE CHECKS

TABLE OF CONTENTS

| <u>NUMBER</u> | | <u>PAGE</u> |
|---------------|---------------------------------|-------------|
| 5-0 | TIME LIMITS/MAINTENANCE CHECKS | |
| | Description/Operation | 1 |
| | General | 1 |
| 5-1-1 | TIME LIMITS | |
| | Description/Operation | 1 |
| | General | 1 |
| | Service Life Limited Components | 1 |
| 5-2-1 | SCHEDULED MAINTENANCE CHECKS | |
| | Description/Operation | 1 |
| | General | 1 |
| | Maintenance Practices | 201 |
| | Annual or 100-hour Inspection | |
| | Procedures | 1 |
| 5-5-1 | UNSCHEDULED MAINTENANCE CHECKS | |
| | Description/Operation | 1 |
| | General | 1 |
| | Maintenance Practices | 201 |
| | Inspection Requirements | 201 |
| | Bondline Damage, Inspection | |
| | Procedures and Repair | 204 |

**AA-5 SERIES
MAINTENANCE MANUAL**

TIME LIMITS/MAINTENANCE CHECKS – DESCRIPTION/OPERATION

1. **General**

This chapter contains the manufacturer's recommended time limits, scheduled and unscheduled maintenance checks and inspections.

**AA-5 SERIES
MAINTENANCE MANUAL**

TIME LIMITS - DESCRIPTION/OPERATION

1. General

The service guide (Figure 1) contains the manufacturers' recommended time limits for inspection, maintenance and overhaul of the airplane, its systems and units.

2. Service Life Limited Components

Recent changes in the Federal Aviation Regulations require that all new aircraft now being certified, for which application for a type certificate was made after September 14, 1969, have the critical wing structure components fatigue strength investigated and that, where applicable, these components be service life limited. Since the AA-5, AA-5A and AA-5B fall into this category, the following service life information is provided. The Model AA-5, AA-5A and AA-5B wing and associated structure have been shown capable of withstanding the repeated loads of variable magnitude expected in service. This was accomplished through a fatigue strength investigation, and as a result of this investigation, discrete service lives have been established for several wing structure components. Those components and their corresponding service lives are listed in Figure 2.

Service life limited parts must be retired from service in accordance with the specified service life hours listed in Figure 2.

All wing and fuselage structural components shall be subject to normal inspection, maintenance, repair and replacement procedures. In addition, to ensure maximum limited life, if corrosion is detected on wing or inboard spars, remove it as quickly as possible and protect the surface from further corrosion in accordance with AC43.13-1A, "Acceptable Methods, Techniques and Practices - Aircraft Inspection and Repair".

**AA-5 SERIES
MAINTENANCE MANUAL**

SCHEDULED MAINTENANCE CHECKS - DESCRIPTION/OPERATION

1. General

The inspection procedures guideline included in this section may be used by the owner, inspector, or mechanic to ensure complete and comprehensive coverage of the inspection requirements. The format of the procedures can be reproduced for ready use by the personnel performing the inspection. The checklist includes the minimum requirements for the 100-hour or annual inspection.

**AA-5 SERIES
MAINTENANCE MANUAL**

| INSPECTION MAINTENANCE | Inspection Interval (Operating Hours) | | | NOTE |
|--|--|-----|------|------|
| | 50 | 100 | 1000 | |
| AIRFRAME | | | | |
| 1. Clean aircraft. | X | X | X | |
| 2. Aircraft structure (especially the spar around the inboard and outboard wing lock shoulder bolts, gear attachments, and fuselage attach collars) | | X | X | i |
| 3. Windows, windshield and canopy | X | X | X | |
| 4. Seats, console, interior and seat belts | X | X | X | |
| 5. Instrument panel, instruments and placards | | X | X | |
| 6. Baggage compartment and cargo tie downs | | X | X | |
| 7. Radio antennas | | X | X | |
| 8. Nose gear torque tube assembly | | X | X | |
| 9. Control T-column and bearings | | X | X | |
| 10. Forward empennage attachments | X | X | X | |
| LANDING GEAR | | | | |
| 1. Strut and upper and lower strut brackets, main gear | | X | X | |
| 2. Strut, torque tube assy, fork and boot assy, nose gear | | X | X | a |
| 3. Nose and main wheel bearing lubrication | | | | b |
| 4. Nose fork swivel lubrication | | X | X | |
| 5. Brake linings and discs | | X | X | |
| 6. Wheel fairings scraper adjustment | | X | X | |
| 7. Main and nose tire pressure | X | X | X | |
| CONTROL SYSTEMS | | | | |
| 1. Cables, turnbuckles, pulleys, guards and terminals | | X | X | |
| 2. Rudder pedals and springs | | X | X | j |
| 3. Flaps, flap actuator, flap actuator jack screw, flap push-pull rods, flap torque tubes, torque tube bearings, bearing supports and position indicator | | X | X | |
| 4. All control Stops | | X | X | |

Service Guide
Figure 1 (Sheet 1 of 4)

**AA-5 SERIES
MAINTENANCE MANUAL**

| INSPECTION MAINTENANCE | Inspection Interval (Operating Hours) | | | NOTE |
|--|--|-----|------|------|
| | 50 | 100 | 1000 | |
| CONTROL SYSTEMS (Continued) | | | | |
| 5. Elevator trim wheel, indicator, indicator shaft and actuator shaft drive screw. Elevator trim tab free play (AA-5A and AA-5B only). | | X | X | l |
| 6. Ailerons, aileron torque tubes, aileron balance weights, bearings and bearing brackets | | X | X | |
| POWERPLANT | | | | |
| 1. Oil Change | X | X | X | |
| 2. Oil Screens and cooler | X | X | X | |
| 3. Replace oil filter if external filter is used | X | X | X | |
| 4. Spark plugs | | X | X | |
| 5. Ignition harness | X | X | X | |
| 6. Magneto timing | | | | c |
| 7. Exhaust system | X | X | X | |
| 8. Throttle, carburetor heat and mixture controls operation | X | X | X | |
| 9. Engine baffles | X | X | X | |
| 10. Air filter | X | X | X | k |
| 11. Engine mount | X | X | X | |
| 12. Oil breather vent | X | X | X | |
| 13. All lines, flex ducts and connections | X | X | X | d |
| 14. Oil and fuel pressures | X | X | X | |
| 15. Propeller and spinner | X | X | X | |
| 16. Alternator belt | X | X | X | |
| 17. Cylinders, crankcase, accessory section, front crankshaft seal | X | X | X | |
| 18. Engine overhaul | | | | e |

Service Guide
Figure 1 (Sheet 2 of 4)

**AA-5 SERIES
MAINTENANCE MANUAL**

| INSPECTION MAINTENANCE | Inspection Interval (Operating Hours) | | | NOTE |
|--|--|-----|------|------|
| | 50 | 100 | 1000 | |
| FUEL SYSTEM | | | | |
| 1. Electric fuel pump filter | X | X | X | |
| 2. Fuel cap gaskets | X | X | X | |
| 3. Fuel overboard vents | X | X | X | |
| 4. Fuel tanks, fuel sumps and drains (4) | | X | X | |
| 5. Fuel selector and placard | | X | X | |
| 6. Fuel gauges | | X | X | |
| 7. All hoses and lines | X | X | X | d |
| 8. Fuel primer | | X | X | |
| UTILITY SYSTEMS | | | | |
| 1. Master cylinder fluid level | X | X | X | |
| 2. Parking brake operation | | X | X | |
| 3. All hoses, lines, and connections | | X | X | |
| 4. Pitot and static systems | | X | X | |
| 5. Pitot line drain | | X | X | |
| 6. Vacuum regulator and filter | | X | X | f |
| 7. Flexible ducts for heating system | | X | X | |
| 8. Cabin heat control operation | | X | X | |
| 9. Compass check | | | X | g |
| 10. Vacuum pump | | | X | h |
| ELECTRICAL SYSTEM | | | | |
| 1. Battery fluid level | X | X | X | |
| 2. Battery hydrometer check | | X | X | |
| 3. All connections | | X | X | |
| 4. All lights for operation | X | X | X | |
| 5. All wiring harnesses and wires | | X | X | |

Service Guide
Figure 1 (Sheet 3 of 4)

**AA-5 SERIES
MAINTENANCE MANUAL**

| INSPECTION MAINTENANCE | Inspection Interval (Operating Hours) | | | NOTE |
|--------------------------------------|--|-----|------|------|
| | 50 | 100 | 1000 | |
| ELECTRICAL SYSTEM (Continued) | | | | |
| 6. Stall warning. | X | X | X | |
| 7. Electric flap motor. | | X | X | |

NOTES:

- a. Remove nose gear strut from torque yoke and inspect for corrosion of the surfaces every 12 calendar months. Remove corrosion and paint surfaces with zinc chromate primer and reassemble wet. Seal strut to yoke connection with RTV-102 by Dow-Corning or equivalent.
- b. Clean and repack wheel bearings at first 100 hours. Inspect wheel bearing grease for contamination and solidification at each annual or 100 hour inspection. Do not exceed 500 wheel miles between repacking intervals.
- c. Maximum time between magneto timing checks 100 hours. Magneto replacement recommended after 900 hours of service.
- d. Recommended replacement of all flexible pressure lines at engine overhaul or every five years, whichever comes first.
- e. Maximum engine overhaul time 2000 hours.
- f. Replace gyros central air filter each 400 hours. Replace vacuum relief valve filter each 1000 hours. For operation in dusty climates, replace filters more frequently.
- g. Check accuracy of compass every 1000 hours or at each time that an item of equipment is installed or removed that could affect the accuracy of the unit.
- h. Recommended replacement of vacuum pump at 1000 hours.
- i. Remove the fuel tank access covers and inspect all internal surfaces and structure for corrosion, cracks, and bonding separation every 2000 hours or at any time the access covers are removed.
- j. Replace rudder springs every 1000 hours.
- k. Recommended replacement of 1975 and later Model AA-5 and AA-5A air filters at 100 hours, 12 calendar months, or when 50 percent covered with foreign material, whichever comes first. AA-5B foam type air filters at 300 hours, 12 calendar months, or when 50 percent covered with foreign material, whichever occurs first. AA-5B paper type air filters at one year, 500 hours or after 10 cleanings.
- l. Measure the elevator trim tab free play every 500 hours. Refer to 27-3-1.

Service Guide
Figure 1 (Sheet 4 of 4)

**AA-5 SERIES
MAINTENANCE MANUAL**

| COMPONENT | AIRCRAFT MODEL | PART NUMBER | SERVICE LIFE (AIRFRAME HRS.) |
|-----------------------------|----------------|--------------|------------------------------|
| Inboard Spar Assembly | AA-5 & 5A | 5102310-501 | 12,000 |
| | AA-5B | 5102310-502 | 12,000 |
| Shoulder Bolt | AA-5 & 5A | 901044-1/-2 | 7,250 |
| | AA-5B | 901044-2 | 7,250 |
| Wing Spar Assembly | AA-5 & 5A | *5201002-501 | 12,500 |
| | AA-5A & 5B | *5201004-501 | 12,500 |
| Wing Outboard Spar Assembly | AA-5 & 5A | *5201189-501 | 12,500 |
| | AA-5B | *5201189-501 | 12,500 |

*Retiring of wing spars from service will generally require simultaneous removal of corresponding wing panel assemblies from service.

Service Life Limited Components
Figure 2

SCHEDULED MAINTENANCE CHECKS - MAINTENANCE PRACTICES

1. Annual or 100-hour Inspection Procedures

A. Perform Annual or 100-Hour Inspection

Complete the inspection by performing each of the procedures detailed on the checklist, Figure 201. Indicate completion by sign-off in the appropriate column.

B. In addition to the Servicing Guide and Annual or 100 Hour Inspection Procedure, the following steps should be adhered to when performing an inspection or overhaul:

(1) Check any FAA Airworthiness Directive or Gulfstream American Service Bulletins/ Letters for compliance at the time specified thereon. Also, appropriate sections of this maintenance manual.

(2) Check that all aircraft documents are present and in order:

Aircraft Airworthiness Certificate (Form FAA 8100-2)

Aircraft Registration Certificate (Form FAA 8050-1 or FAA 8050-3)

Weight and Balance Sheet

Aircraft Equipment List

Any Repair and Alteration Forms if applicable (Form FAA 337)

Aircraft Radio Station License if applicable (Form FCC 566 or FCC 453B)

Aircraft and Engine Log Books

NOTE: All of the above items except the log books must be carried in the aircraft at all times. Form FAA 8100-2, FAA 8050-3 and FCC 566 (FCC 453-B) must be visually displayed.

(3) Check that operating limitations placards (reference Chapter 11) are displayed.

**AA-5 SERIES
MAINTENANCE MANUAL**

MODELS AA-5, AA-5A & AA-5B
ANNUAL OR 100 - HOUR INSPECTION PROCEDURE

ANNUAL OR 100 HOUR INSPECTION PROCEDURE GUIDELINE

FAR 43.15 (C) (1) states: "Each person performing an annual or 100 hour inspection shall use a check list while performing the inspection. The check list may be of the person's own design, one provided by the manufacturer of the equipment being inspected, or one obtained from another source. This checklist must include the scope and detail of the items contained in appendix D to this part and paragraph (b) of this section." The following pages contain a comprehensive annual or 100 hour inspection procedure check list. This check list has been prepared to assist a mechanic in performing a detailed inspection of such scope and detail that when the inspection is completed, the mechanic is absolutely sure that he has not overlooked any areas, even though he may not have previous experience on this particular model aircraft. Once a mechanic becomes familiar with this aircraft, he may wish to prepare his own check list, which must be within the scope of appendix D of FAR part 43.

| | | | | |
|-----------------------|---------------|----------------|---------------------------|--|
| OWNER'S NAME | | STREET ADDRESS | | |
| CITY | | STATE | ZIP CODE | |
| IDENTIFICATION NUMBER | SERIAL NUMBER | HOURS | DATE INSPECTION COMPLETED | |
| SERVICING AGENCY | CITY | | STATE | |

Check for conformity with FAA Specifications, Airworthiness Directives and Gulfstream American Corporation and Supplier's Service Bulletins and Letters.

N O T E

It is recommended that reference be made to the applicable maintenance handbook, service bulletins, letters, installation instructions, and vendor specifications for torque values, clearances, settings, tolerances and other specification data.

Inspection Procedure Guideline
Figure 201 (Sheet 1 of 13)

**AA-5 SERIES
MAINTENANCE MANUAL**

MODELS AA-5, AA-5A & AA-5B
ANNUAL OR 100 - HOUR INSPECTION PROCEDURE

| MODELS AA-5, AA-5A & AA-5B ANNUAL OR 100 - HOUR INSPECTION PROCEDURE | | | | |
|--|---|--|---|-------|
| PRE-INSPECTION ENGINE RUN UP Prior to beginning the Annual or 100 hour inspection, an engine run up is to be made to facilitate oil drainage and to observe the following, noting any discrepancies: | | | MECH | INSP. |
| 1. | Fuel Pressure (0.5 to 8 PSI) Electric Pump only prior to engine start up _____ Engine Pump only after engine start up _____ Both _____ | | | |
| 2. | Oil Pressure (60 to 90 PSI) (Approx. 25 PSI idling) Actual _____ Actual _____ | | | |
| 3. | Magneto RPM Drop (175 RPM maximum drop on either magneto; no more than 50 RPM difference between magnetos.) Actual Drop Left _____ Right _____ | | | |
| 4. | Static RPM: | AA-5 & AA-5A (2250-2375) Actual _____ | AA-5B (2150-2275) Actual _____ | |
| 5. | Idling Speed: | AA-5 & AA-5A (600 to 650 RPM) Actual _____ | AA-5B (500 to 650 RPM) Actual _____ | |
| 6. | Ammeter (no steady discharge in normal operating range) | | | |
| 7. | Suction Gauge (4.6 to 5.4 In. Hg.) | | | |
| 8. | Fuel Selector (check operation in all positions) | | | |
| 9. | Carburetor Heat Control | | | |
| 10. | Engine Response to change in power | | | |
| 11. | Idle cut-off | | | |

Inspection Procedures Guideline
Figure 201 (Sheet 2 of 13)

**AA-5 SERIES
MAINTENANCE MANUAL**

**MODELS AA-5, AA-5A & AA-5B
ANNUAL OR 100 - HOUR INSPECTION PROCEDURE**

| A. PROPELLER GROUP | MECH. | INSP. |
|---|--------------|--------------|
| 1. Remove spinner and check for cracks, scratches, scoring, dents, nicks and distortions. | | |
| 2. Inspect blades for erosion, scratches, nicks and cracks. Dress out nicks as required | | |
| 3. Inspect spinner back plate, bulkheads and doubler for cracks and secure mounting. | | |
| 4. Check front crankshaft seal for oil leaks | | |
| *5. Check propeller mounting bolt torque: _____Foot pounds or _____inch pounds. Resafety propeller, mounting bolts. | | |
| *6. Reinstall spinner. Check spinner run out _____inch maximum. | | |
| B. ENGINE GROUP | MECH. | INSP. |
| 1. Remove engine cowl. Clean and check for cracks, wear, distortion, loose or missing fasteners and landing light attachment | | |
| 2. Drain oil sump. Remove oil screens, clean and inspect for metal particles. Reinstall and resafety. Replace oil filter (If installed). Cut apart and inspect old filter for metal particles | | |
| 3. Check oil temperature sending unit, oil lines, cooler, and fittings for leaks, chafing, dents, cracks, and secure mounting. | | |
| 4. Fill engine with oil per lubrication chart. | | |
| 5. Clean engine. | | |
| 6. Check engine cylinder compression #1.____ #2.____ #3.____ #4.____ | | |
| 7. Clean and regap or replace spark plugs as required (See latest revision of Lycoming Service Instruction No. 1042) | | |

*Refer to Maintenance Manual Chapter 61 and insert required values here applicable to your aircraft for quick reference during inspection.

**AA-5 SERIES
MAINTENANCE MANUAL**

**MODELS AA-5, AA-5A & AA-5B
ANNUAL OR 100 - HOUR INSPECTION PROCEDURE**

| B. ENGINE GROUP (Continued) | MECH. | INSP. |
|--|-------|-------|
| 8. Check ignition harnesses. Clean and inspect insulators | | |
| 9. Check magnetos to engine timing, oil seal leakage, and distributor block for cracks, burned areas and corrosion | | |
| 10. Remove and service air filter (see Chapter 73 for details). Inspect carburetor heat control valve plate, shaft, valve plate to shaft screws and bearings for signs of wear and security. Replace filter and/or gasket if damaged or defective. Reinstall carburetor air filter | | |
| 11. Check induction air intake seals for leaks, deterioration and hardness. Check flex ducts for broken or loose strings, loose or displaced supporting wire and general overall condition for signs of wear or perforation | | |
| 12. Drain carburetor bowl. Reinstall drain plug. Remove and clean carburetor fuel inlet screen with acetone. Reinstall screen | | |
| 13. Remove and clean electric fuel pump filter. Reinstall and resafety | | |
| 14. Check fuel pump for proper operation and secure mounting. Pressurize fuel system with electric pump and inspect fuel system and lines for leaks. Check fuel primer for operation and line leaks | | |
| 15. Check starter for secure mounting | | |
| 16. Check security of throttle arm on carburetor. Check throttle, carburetor heat, and carburetor mixture controls for proper travel, security, operating condition and control cushion | | |
| 17. Remove exhaust shroud and check muffler tailpipe, risers, clamps, gaskets and exhaust system for cracks, leaks and secure mounting. Reinstall shroud | | |

Inspection Procedures Guideline
Figure 201 (Sheet 4 of 13)

**AA-5 SERIES
MAINTENANCE MANUAL**

**MODELS AA-5, AA-5A & AA-5B
ANNUAL OR 100 - HOUR INSPECTION PROCEDURE**

| B. ENGINE GROUP (Continued) | MECH. | INSP. |
|---|-------|-------|
| 18. Check breather tube for obstructions and secure mounting . . . | | |
| 19. Inspect cylinders for evidence of excessive heat indicated by burned paint on the cylinder. Check for cracks, loose bolts, oil leaks and general condition | | |
| 20. Inspect engine mount for cracks, secure mounting and proper safety wiring. Check rubber vibration dampeners for signs of deterioration. Replace as required | | |
| 21. Check all baffles for cracks, loose or missing screws and deteriorated seal material | | |
| 22. Check alternator for secure mounting and lugs and brackets for cracks. Check condition and tension of alternator drive belt. Replace if required. (Adjust belt tension to yield a 5/16 in. deflection at the center of the belt when applying a pressure equivalent to 14 pounds for new belts and 10 pounds for used belts | | |
| 23. Check battery electrolyte level and specific gravity. Clean and tighten battery terminals. Check battery box drains and vents for condition and drainage clear of aircraft structure . . | | |
| 24. Inspect vacuum system components (if installed) for secure mounting. Check vacuum pump drive for evidence of seal leakage. Replace seal and pump if required. Check all inter-connecting lines and fittings for leaks, deterioration and damage. Replace as required | | |
| 25. Check ground straps for condition and secure attachment | | |
| 26. Check electrical wiring for condition and secure connections including shielded cable ground connections | | |

Inspection Procedures Guideline
Figure 201 (Sheet 5 of 13)

**AA-5 SERIES
MAINTENANCE MANUAL**

| MODELS AA-5, AA-5A & AA-5B ANNUAL OR 100 - HOUR INSPECTION PROCEDURE | | |
|---|-------|-------|
| B. ENGINE GROUP (Continued) | MECH. | INSP. |
| 27. Check voltage regulator, starter relay and master switch relay for secure mounting and proper operation | | |
| 28. Install cowl, checking for proper engagement of air intake duct and cowl latches | | |
| C. CABIN GROUP | MECH. | INSP. |
| 1. Remove front seats, fold rear seat forward, remove cover from rear seat support and remove console side panels | | |
| 2. Check windshield, windows and canopy for cracks and secure mounting. Clean and lubricate canopy rails. Check canopy operation and locking devices | | |
| 3. Check seat belts and shoulder harnesses for condition and secure mounting | | |
| 4. Check elevator trim control for condition, secure mounting, proper operation and indication | | |
| 5. Check rudder pedal and brake system for proper operation and condition. Check brake fluid level. Replace rudder pedal springs at 1000 hours | | |
| 6. Check control "T" for secure mounting and adequate clearance from other equipment | | |
| 7. Check chains, cables, pulleys, turnbuckles and cable ends for condition, secure attachment and safeties. Specifically check cables at pulleys for fraying while actuating controls through full travel. (Max. of four broken wires acceptable) | | |
| 8. Check cable tension at the average temperature for aircraft operation | | |
| 9. Check all controls for clearance and proper operation | | |

Inspection Procedures Guideline
Figure 201 (Sheet 6 of 13)

**AA-5 SERIES
MAINTENANCE MANUAL**

| MODELS AA-5, AA-5A & AA-5B ANNUAL OR 100 - HOUR INSPECTION PROCEDURE | | |
|--|-------|-------|
| C. CABIN GROUP (Continued) | MECH. | INSP. |
| 10. Check all interior bond lines for any indications of damage, peeling or cracking | | |
| 11. Check nose gear torque tubes and mounting brackets and bond joints for cracks and secure mounting. Check torque on mounting bolts - center bearing bracket bolts 185-195 in. lb and end plate bolts 300-350 in. lb | | |
| 12. Check flap actuator, push rods, limit switches and indicator for proper operation and secure mounting | | |
| 13. Lubricate per lubrication chart (Chapter 12) | | |
| 14. Check all plumbing in cabin for leaks and condition | | |
| 15. Disassemble, clean, lubricate and reassemble fuel selector valve every 500 hours. See fuel system section for details | | |
| 16. Check gyro system filters (if installed), replace if necessary. . . | | |
| 17. Check instruments for condition, secure mounting and legible markings. | | |
| 18. Check electrical wiring switches, lights and electronic equipment for condition and security | | |
| 19. Inspect baggage compartment, baggage door and cargo tie-downs. | | |
| 20. Inspect all placards in cabin for condition and legibility | | |
| 21. Reinstall cover over rear seat support, console side panels and front seats | | |
| 22. Check fresh air vents for proper operation | | |
| 23. Check and verify correct quantity and rating of spare fuses mounted in right side of glove box | | |
| D. FUSELAGE AND EMPENNAGE GROUP | MECH | INSP. |
| 1. Remove tailcone and empennage covers. | | |
| 2. Inspect emergency locator transmitter for security, operation and battery expiration date | | |

Inspection Procedures Guideline
Figure 201 (Sheet 7 of 13)

**AA-5 SERIES
MAINTENANCE MANUAL**

**MODELS AA-5, AA-5A & AA-5B
ANNUAL OR 100 - HOUR INSPECTION PROCEDURE**

| MODELS AA-5, AA-5A & AA-5B ANNUAL OR 100 - HOUR INSPECTION PROCEDURE | | |
|--|--------------|--------------|
| D. FUSELAGE AND EMPENNAGE GROUP (Continued) | MECH. | INSP. |
| 3. Inspect exterior surfaces for condition and damage. Check all drain holes in the fuselage bottom for obstructions | | |
| 4. Inspect bond lines for any indication of damage, peeling or cracks | | |
| 5. Check ventral fin (Model AA-5), horizontal and vertical stabilizers for damage and secure mounting. Insure that horizontal stabilizer and elevator drain holes are open | | |
| 6. Check elevator, elevator bearings and stops, rudder, rudder bearings and stops, tab hinges and bellcranks for damage, travel and proper operation. Maximum allowable torque tube wear limit at bearing supports is 0.030 in. reduction in wall thickness | | |
| 7. Check elevator trim mechanism for damage, secure mounting and proper operation | | |
| 8. Check rudder and elevator cables and pulleys for damage, proper operation and safeties. Check bellcrank attaching bolts for wear. | | |
| 9. Lubricate per lubrication chart. (Chapter 12) | | |
| 10. Inspect antenna mountings, wiring and electronic installations . . | | |
| 11. Check position and anti-collision light (s) for secure mounting. . . | | |
| 12. Check static system lines and the alternate air source valve (if so equipped). Drain any accumulated moisture from system drain | | |
| 13. Reinstall inspection covers | | |

Inspection Procedures Guideline
Figure 201 (Sheet 8 of 13)

**AA-5 SERIES
MAINTENANCE MANUAL**

MODELS AA-5, AA-5A & AA-5B
ANNUAL OR 100 - HOUR INSPECTION PROCEDURE

| E. WING GROUP | MECH. | INSP. |
|--|-------|-------|
| 1. Remove wing tips and access panels. Inspect surfaces, skins, ribs and tips for damage. Check position and anti-collision lights for secure mounting. Insure that all wing drain holes are open | | |
| 2. Visually inspect interior and exterior bond lines for any indication of damage, peeling or cracks | | |
| 3. Check ailerons, aileron bearings and stops, flaps, and flap bearings for secure mounting, damage, proper travel and wear. Maximum allowable aileron torque tube wear limit at bearing supports is 0.030 in. reduction in wall thickness. Check that aileron flap and drain holes are open. Check that aileron balance weight tube arm I. D. is open, corrosion free and zinc coated (early aircraft only) | | |
| 4. Check fuel vents and connecting lines for damage and restrictions . | | |
| 5. Check fuel tanks, sump tanks and lines for evidence of leakage. Check sump tanks and lines for secure mounting | | |
| 6. Check fuel cap gaskets for air tight seal | | |
| 7. Check wing and outboard wing section attaching bolts. Torque to 60-85 in. lb | | |
| 8. Inspect fuel tank placards | | |
| 9. Check pitot heating element for proper operation (if installed) . . . | | |
| 10. Check pitot tube opening and lines. Drain accumulated moisture. . | | |
| 11. Check for interior corrosion of skin indicated by a white flaking ash. | | |

Inspection Procedures Guideline
Figure 201 (Sheet 9 of 13)

**AA-5 SERIES
MAINTENANCE MANUAL**

| MODELS AA-5, AA-5A & AA-5B ANNUAL OR 100 - HOUR INSPECTION PROCEDURE | | |
|--|-------|-------|
| F. MAIN LANDING GEAR GROUP | MECH. | INSP. |
| 1. Remove wheels and check for cracks. Check condition of brake linings, wheel cylinders, torque plates and mounting pins. Pack wheel bearings, reinstall wheels and key axle nuts at first 100 hours and each 500 hours thereafter. Inspect wheel bearing grease for contamination and solidification at each annual or 100 hour inspection. For operation in dusty areas or areas of high humidity, repack every 100 hours. Perform a complete wheel inspection when tires are replaced | | |
| 2. Check tires for approved type, wear and proper inflation | | |
| 3. Check brake lines for leaks and secure attachment | | |
| 4. Check struts for secure mounting. Inspect for cracks, delamination and nicks | | |
| 5. Inspect the upper main mounting brackets and spar attaching supports (center spar to fuselage) for wear, cracks and loose bolts | | |
| 6. Inspect wheel and strut fairings for damage and secure mounting (if installed) | | |
| G. NOSE GEAR GROUP | MECH. | INSP. |
| 1. Check nose gear strut for secure mounting, deformation, damage and cracks | | |
| 2. Remove nose gear strut from torque yoke and inspect for corrosion of the faying surfaces every 12 calendar months. Remove corrosion if present, paint surfaces with zinc-chromate and reassemble wet. Seal strut to yoke connection with RTV-102 by DOW CORNING | | |
| 3. Remove and check nose gear fork for deformation, wear and cracks. Maximum fork to strut bearing clearance is 0.035 in. | | |

Inspection Procedures Guideline
Figure 201 (Sheet 10 of 13)

**AA-5 SERIES
MAINTENANCE MANUAL**

| MODELS AA-R, AA-5A & AA-5B ANNUAL OR 100 - HOUR INSPECTION PROCEDURE | | |
|--|-------|-------|
| G. NOSE GEAR GROUP (Continued) | MECH. | INSP. |
| 4. Grease fork and friction dampener, assemble to strut and tighten to 10-22 lb. drag at axle | | |
| 5. Remove nose wheel, check for cracks, clean, inspect and repack bearings, reinstall wheel and safety axle at first 100 hours and each 500 hours thereafter. Inspect wheel bearing grease for contamination and solidification at each annual or 100 hour inspection. For operation in dusty areas or areas of high humidity, repack every 100 hours. Perform a complete wheel inspection when tire is replaced | | |
| 6. Inspect nose wheel for cracks, corrosion and loose or broken bolts | | |
| 7. Check tire for approved type, wear and proper inflation. | | |
| 8. Check wheel fairing for damage and secure mounting (If installed) | | |
| H. OPERATIONAL INSPECTION | MECH. | INSP. |
| 1. Check brake operation (including parking brake) | | |
| 2. Check fuel primer operation and lines for leaks | | |
| 3. Check booster pump operation | | |
| 4. Check fuel pressure | | |
| 5. Check starter for proper operation | | |
| 6. Check oil pressure and temperature | | |
| 7. Check engine controls for proper operation. Check throttle control for proper cushion | | |

Inspection Procedures Guideline
Figure 201 (Sheet 11 of 13)

**AA-5 SERIES
MAINTENANCE MANUAL**

MODELS AA-5, AA-5A & AA-5B
ANNUAL OR 100 - HOUR INSPECTION PROCEDURE

| H. OPERATIONAL INSPECTION (Continued) | MECH. | INSP. |
|---|-------|-------|
| 8. Check magneto operation; both ON, left OFF; both ON, right OFF; both ON. (Maximum magneto drop 175 RPM with 50 RPM maximum difference between magnetos). With engine at idle, turn switch to OFF position momentarily to check magneto grounding | | |
| 9. Check engine static RPM: 2250-2375, Model AA-5 and AA-5A 2150-2275, Model AA-5B | | |
| 10. Check carburetor heater for proper operation | | |
| 11. Check alternator output | | |
| 12. Check suction gauge and vacuum system output 4.6 to 5.4 in Hg. | | |
| 13. Check fuel selector valve operation and indexing | | |
| 14. Check heating, defrosting and ventilating system for proper operation. | | |
| 15. Check radio for proper operation | | |
| 16. Check engine mixture setting and idle speed: 600-650 RPM, Model AA-5 and AA-5A; 500-650 RPM, Model AA-5B. | | |
| 17. Check idle cut off on carburetor for proper operation | | |
| 18. Check ailerons for proper operation | | |
| 19. Check elevators and trim tabs for proper operation. | | |
| 20. Check flaps for proper operation. | | |
| 21. Check fuel quantity gauges for condition and proper operation . . | | |

Inspection Procedures Guideline
Figure 201 (Sheet 12 of 13)

**AA-5 SERIES
MAINTENANCE MANUAL**

**MODELS AA-5, AA-5A & AA-5B
ANNUAL OR 100 - HOUR INSPECTION PROCEDURE**

| MODELS AA-5, AA-5A & AA-5B ANNUAL OR 100 - HOUR INSPECTION PROCEDURE | | |
|--|-------|-------|
| H. OPERATIONAL INSPECTION (Continued) | MECH. | INSP. |
| 22. Check interior lights for proper operation and adjustment. . . . | | |
| 23. Check navigation and anti-collision lights for proper operation and landing lights for proper operation and adjustment | | |
| 24. Check pitot heat for proper operation. | | |
| 25. Check stall warning device for operation | | |
| 26. Inspect engine after ground run-up. Flight test and inspect for oil leaks and secure mounting of all components | | |
| I. GENERAL | MECH. | INSP. |
| 1. Aircraft cleaned and serviced | | |
| 2. Aircraft conforms to FAA Specifications | | |
| 3. All FAA Airworthiness Directives complied with | | |
| 4. All manufacturer's Service Letters and Bulletins complied with | | |
| 5. Checked for proper Owners Manuals or Pilots Operating Handbook. | | |
| 6. Aircraft papers in proper order. Make log book entry | | |

"END OF INSPECTION"

Inspection Procedures Guideline
Figure 201 (Sheet 13 of 13)

AA-5 SERIES
MAINTENANCE MANUAL

UNSCHEDULED MAINTENANCE CHECKS — DESCRIPTION/OPERATION

1. General

Following a hard landing, certain items and systems of the aircraft should be inspected for subsequent damage. Applicable groups in Figure 201, 5-2-1 should be used as a guideline when performing the unscheduled inspections required as a result of unusual circumstances. For example, if the landing gear requires an unscheduled inspection, each procedure listed under the landing gear group should be completed.

AA-5 SERIES
MAINTENANCE MANUAL

UNSCHEDULED MAINTENANCE CHECKS - MAINTENANCE PRACTICES

1. Inspection Requirements

A. Inspect Main Landing Gear Assembly

- (1) Remove rubber fairing and thoroughly inspect the fiberglass struts for evidence of nicks, cracks, delamination, and deterioration of the protective paint coating (See Figure 201).

NOTE: Minor surface delaminations are acceptable providing they do not extend more than one ply into the surface of the strut. Corner delaminations (slivers) are acceptable if they are smaller than $1/16 \times 1/16$ inch in size throughout their length. If air-worthiness of a damaged fiberglass strut is in question, close-up photographs of the damaged area may be submitted to the Customer Service Department for analysis and recommendations.

- (2) Minor imperfections may be repaired. Struts with other minor imperfections must be replaced.

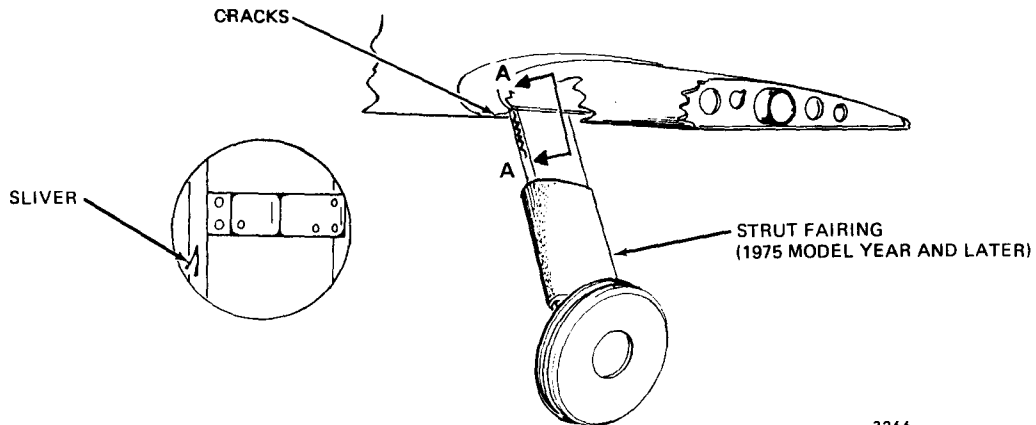

3266

Main Gear Strut
Figure 201

- (3) Inspect main gear attach brackets for deformation, proper bolt torque and evidence of movement on the spar. If spring plate (Item 20, Figure 201, Chapter 32-1-1) between brackets and strut is bent, it must be replaced.
- (4) Check brackets for hole elongation.

B. Inspect Nose Landing Gear Assembly

- (1) Inspect the nose gear fork assembly and axle rod for deformation or cracks as shown in Figure 202. This damage normally results from a landing at a relatively flat attitude with a high vertical velocity. Any evidence of deformation or cracks is cause for rejection of the fork assembly and/or axle rod.

AA-5 SERIES
MAINTENANCE MANUAL

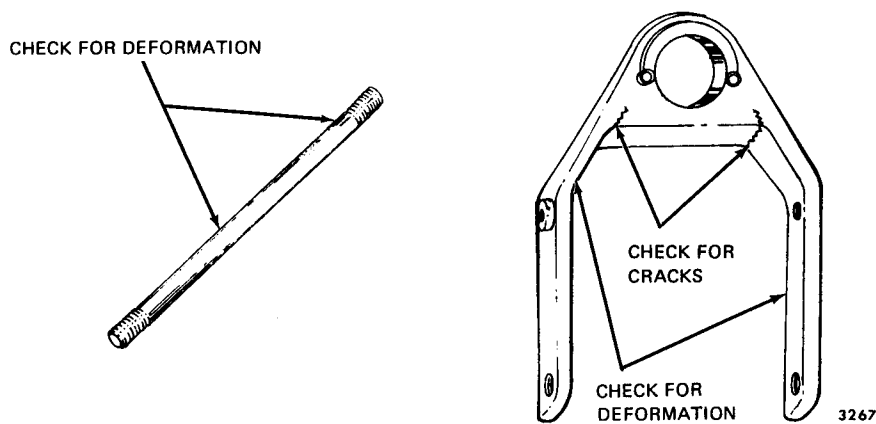

Nose Gear Axle Rod and Fork Assembly
Figure 202

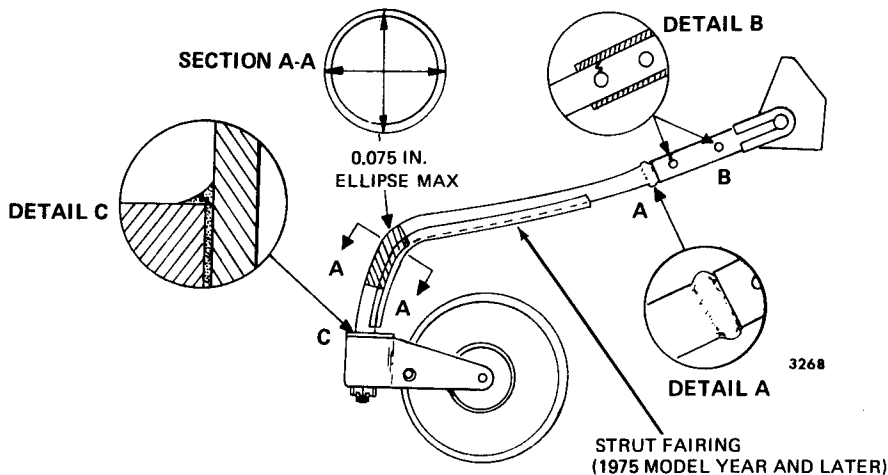

Nose Gear Strut
Figure 203

- (2) Deformation shown in Detail A, Figure 203, is the result of landing in a relatively flat attitude with high vertical velocity. Replace strut if deformed.
- (3) Inspect the curved area of the strut for flattened condition as shown in Section A-A, Figure 203. An ellipsed area exceeding 0.075 in. is cause for rejection of the strut.

NOTE: On Aircraft 1975 model year and later nose gear struts have a streamlining fairing attached to the aft side. This fairing must be removed to perform the visual inspection.

- (4) With the weight removed from the nose landing gear, check the fit of the strut assembly into the torque tube yoke assembly by moving the strut up and down in the torque tube Tee. If looseness is noted, the cause for looseness must be determined. If the bolts that attach the strut to the torque tube yoke are worn, they should be replaced with NAS464-P6A28 bolts. If new bolts do not satisfactorily eliminate play, ream and install next larger size NAS bolt (NAS464-P7 maximum).

**AA-5 SERIES
MAINTENANCE MANUAL**

- (5) With strut removed, inspect bolt hole areas at strut to torque tube attach point for evidence of elongation or cracking.
- (6) Inspect the nose fork bearing cup to nose strut bond joint for cracks, corrosion, deterioration, or damage (see Detail C, Figure 203).
- (7) Inspect torque tube assembly attachment to fuselage side panels as shown in Figure 204. Remove snap plugs and check location of attach bolts. If bolts have shifted and are not exactly in the center of the counterbored holes in the fuselage sides, damage may have occurred to the lower engine mount/fuselage area. A very close inspection of this area should be accomplished.

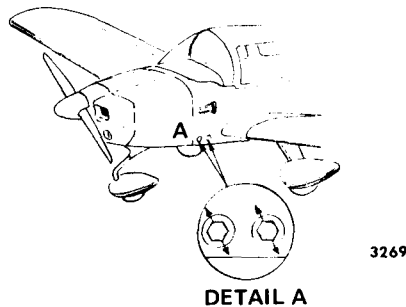

Torque Tube Assembly Attachment
Figure 204

- (8) Inspect bond fillets in torque tube and yoke assembly as shown in Figure 205. If cracks are noted in paint or in the bond fillets, they should be carefully sanded out to determine that they do not extend into the bonded joint. Cracks in the bond fillets are permissible. Cracks in the bonded joints are not permissible and torque tube assembly must be removed from service.

NOTE: In cases of severe overload the bond joints may actually fail in the outboard end of the torque tube and yoke assembly, allowing one or both of the torque tubes to rotate in the end fittings.
- (9) Inspect the torque tubes for longitudinal cracks, as shown in Figure 205.
- (10) Inspect cabin floor and firewall where torque tube center bearing support brackets attach for evidence of deformed honeycomb. Inspect torque tube center bearing support brackets for deformation. If torque tube center bearing support brackets are deformed, the entire tube assembly must be replaced.

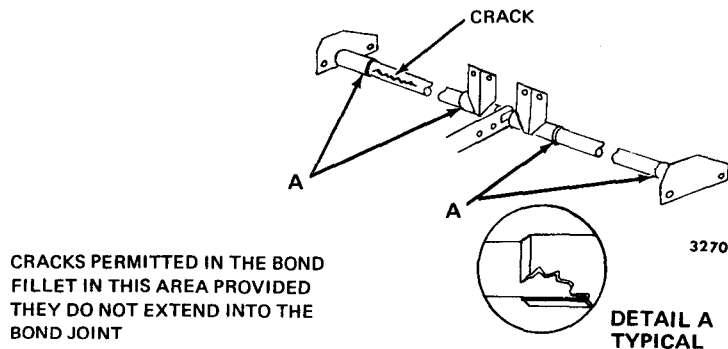

Torque Tube and Yoke Assembly
Figure 205

**AA-5 SERIES
MAINTENANCE MANUAL**

C. Inspect Engine Mounts and Propellers

- (1) Inspect engine mount welded assembly for cracks or any deformation.
- (2) Inspect attach fittings at fuselage for cracks, deformation, and security of attachment to fuselage.
- (3) Inspect the tips of the propeller for evidence of ground contact. Replace a bent or damaged propeller.

D. Inspect Fuselage and Empennage Items

- (1) Inspect ventral fin (AA-5 only) and attachments to fuselage for evidence of damage or bond separation of aft bulkhead to fuselage side and bottom attachment. Repair in this area may be accomplished in accordance with AC43.13-1 or with data obtainable from Grumman American Engineering Dept.
- (2) Inspect the tailcone structure for damage. Buckled tailcone flanges can normally be repaired using the procedures from AC 43.
- (3) Inspect bond lines for evidence of damage or cracks.
- (4) Inspect horizontal and vertical stabilizer, elevator, rudder and aileron mounting brackets for damage, cracks, security of mounting, loose bolts, or buckled supports.

2. Bondline Damage, Inspection Procedures and Repair

A. Isolate Most Commonly Damaged Area.

- (1) Areas which should be given particular attention include: flanges of wing and stabilizer rear spars, trailing edges of control surfaces, the side lap joint between the tailcone and forward cabin section, the joint between the tailcone top and side skin, and the aft tailcone bulkhead joints.
- (2) Inside edges and internal joints which have an undisturbed bondline fillet are generally not affected.

B. Identify Types of Damage

- (1) Physical Damage - The most common type of bondline damage is physical damage along the trailing edges of the flaps, ailerons, elevators and rudder. This is caused by persons stepping on the inboard trailing edges of the flaps and general "hangar rash" on the other control surfaces. This type of damage is usually readily visible in the form of joint separation.
- (2) Corrosion Damage - A less common type of bondline damage is damage caused by metal corrosion. This type of damage is usually restricted to edges of unfilleted bondlines, such as found on the rear spar to skin joints on the trailing edges of wings and stabilizers, particularly if these edges are not well protected by paint. This type of damage is more likely in tropical and subtropical climates, particularly where an aircraft is located close to the coast.

C. Locate and Verify Damaged Areas

- (1) Visual Scanning - Carefully scan the edges of all joints in a well-lighted location or outside in daylight to determine the existence of hairline cracks between two layers of bonded metal. Figure 206 shows the appearance of this condition. Identify the location of any cracks with a grease pencil as shown in Figure 206.

AA-5 SERIES
MAINTENANCE MANUAL

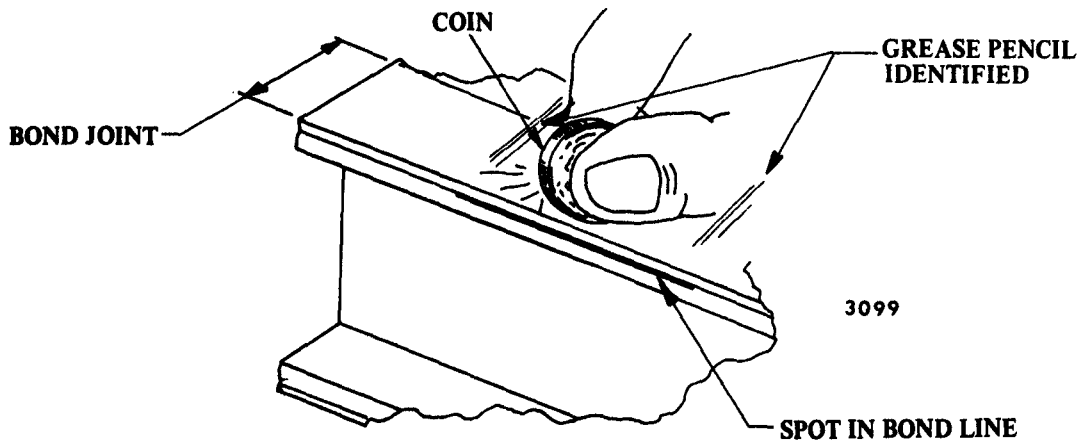

Identifying Suspect Areas
Figure 206

- (2) **Tapping** — Gently tap the bondline with a coin or similar metal object to verify the existence of a bondline separation. Slowly move along the bondline, while tapping, and listen for a change in tone as the suspect area is traversed. A bondline separation will produce a flat or hollow sound when tapped directly in the damaged area.
- (3) **Separation** — If bondline separation cannot be positively verified by tapping the area with a coin, attempt to insert a 0.004 to 0.006 inch feeler gauge into the bondline to verify that a separation exists.

D. Repair Bondline Damage

- (1) If the suspected damage proves to be no actual separation, the hairline should be wiped with MEK and sealed with paint.
- (2) Seal all bare bondline edges with paint.
- (3) If the suspected damage proves to be actual bondline separation, order Service Kit No. SK-125 from the Customer Service Department and make the repairs accordingly.

AA-5 SERIES
MAINTENANCE MANUAL

CHAPTER 6
DIMENSIONS AND AREAS
TABLE OF CONTENTS

| <u>NUMBER</u> | | <u>PAGE</u> |
|---------------|---|-------------|
| 6-0 | PRINCIPAL DIMENSIONS | |
| | General | 1 |
| | Principal Dimensions (AA-5 Aircraft) | 1 |
| | Principal Dimensions (AA-5A and AA-5B Aircraft) | 1 |
| 6-1-1 | STATION LOCATIONS | |
| | General | 1 |
| | Station Locations (AA-5 Aircraft) | 1 |
| | Station Locations (AA-5A and AA-5B Aircraft) | 1 |
| 6-2-1 | SPECIFICATIONS | |
| | General | 1 |
| | Specifications, AA-5, AA-5A and AA-5B Aircraft | 1 |

**AA-5 SERIES
MAINTENANCE MANUAL**

PRINCIPAL DIMENSIONS

1. General

This section provides, in diagram form, the principal dimensions for the AA-5, AA-5A and AA-5B aircraft.

2. Principal Dimensions (AA-5 Aircraft)

Principal dimensions for the AA-5 aircraft are presented in Figure 1.

3. Principal Dimensions (AA-5A and AA-5B Aircraft)

Principal dimensions for the AA-5A and AA-5B aircraft are presented in Figure 2.

AA-5 SERIES
MAINTENANCE MANUAL

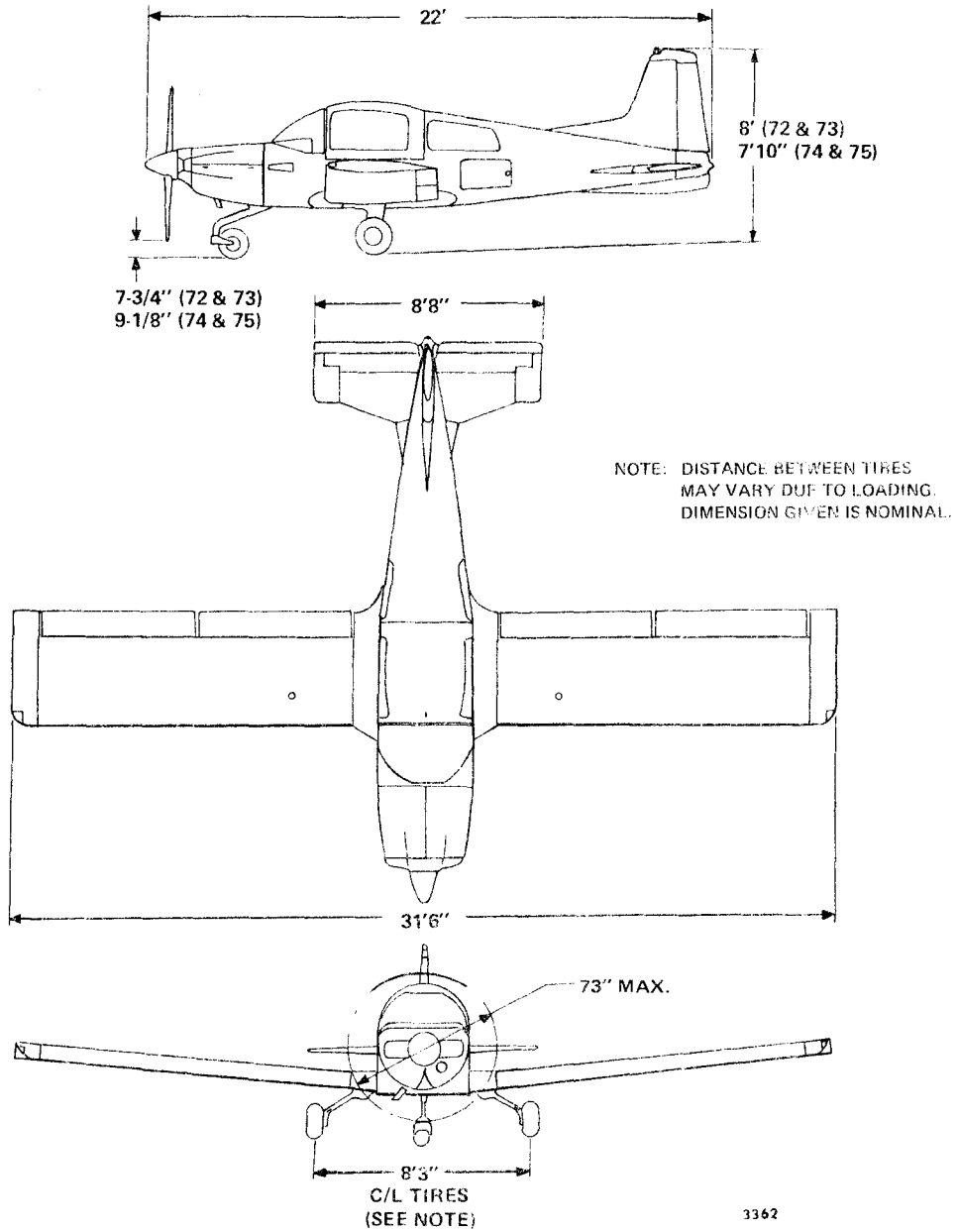

Principal Dimensions (AA-5 Aircraft)
Figure 1

**AA-5 SERIES
MAINTENANCE MANUAL**

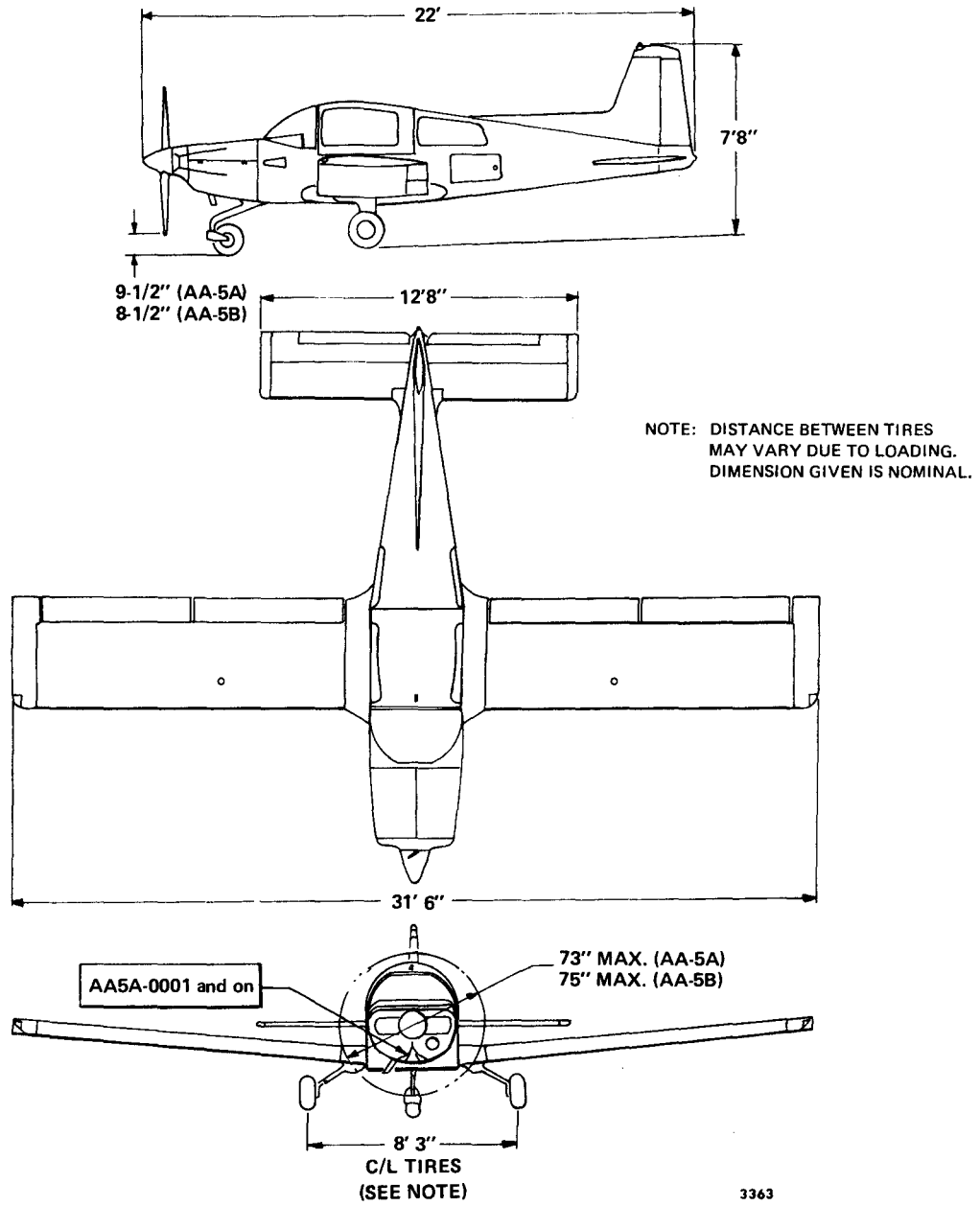

**Principal Dimensions (AA-5A and AA-5B Aircraft)
Figure 2**

**AA-5 SERIES
MAINTENANCE MANUAL**

STATION LOCATIONS

1. **General**

This section provides, in diagram form, the station locations for the AA-5, AA-5A and AA-5B aircraft.

2. **Station Locations (AA-5 Aircraft)**

Station locations for the AA-5 aircraft are presented in Figure 1.

3. **Station Locations (AA-5A and AA-5B Aircraft)**

Station locations for the AA-5A and AA-5B aircraft are presented in Figure 2.

**AA-5 SERIES
MAINTENANCE MANUAL**

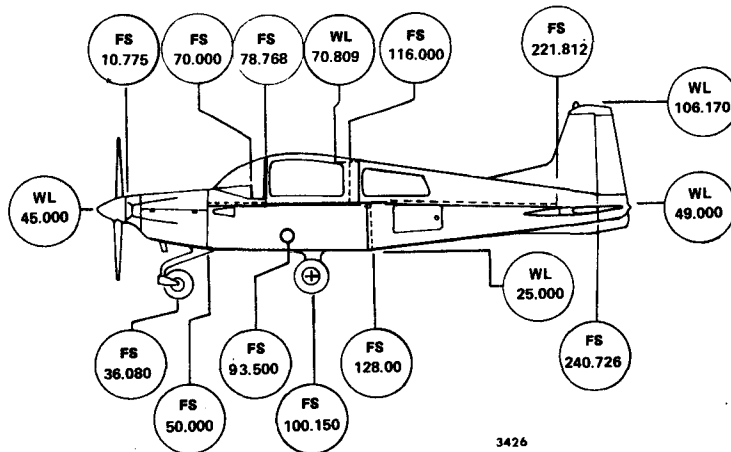
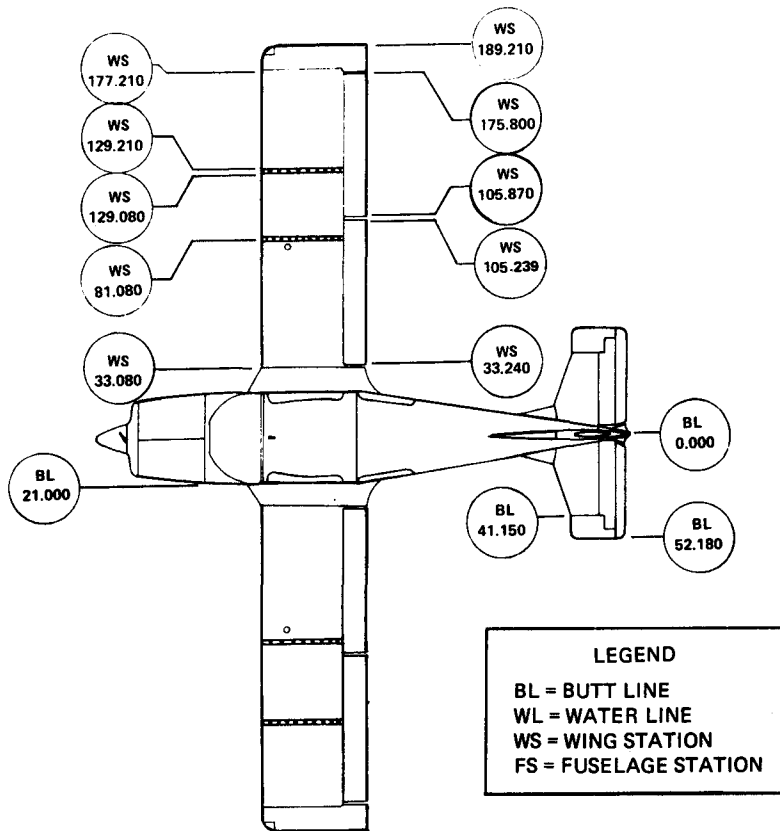

3426

Station Locations (AA-5 Aircraft)
Figure 1

**AA-5 SERIES
MAINTENANCE MANUAL**

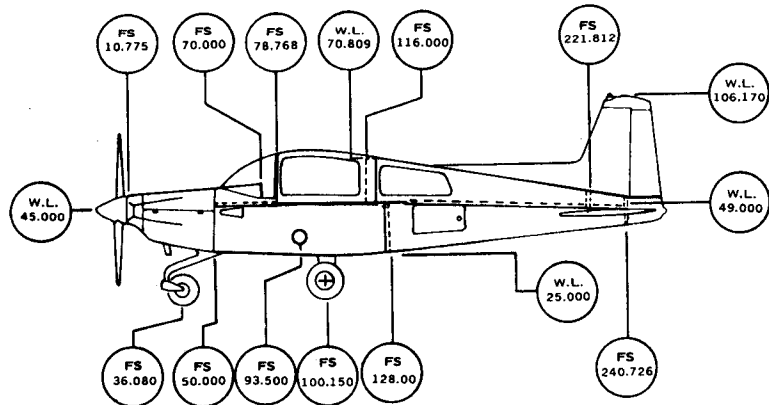
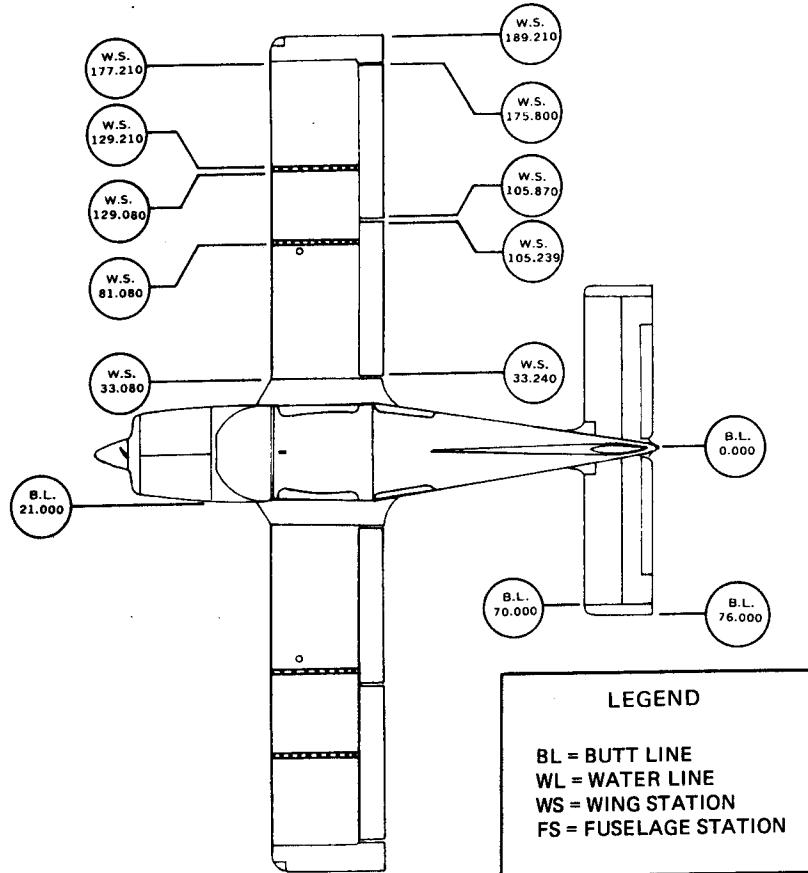

Station Locations (AA-5A and AA-5B Aircraft)
 Figure 2

**AA-5 SERIES
MAINTENANCE MANUAL**

SPECIFICATIONS

1. General

This section provides, in tabular form, the major specifications for the AA-5, AA-5A and AA-5B aircraft.

2. Specifications, AA-5, AA-5A and AA-5B Aircraft

The major specifications for the AA-5, AA-5A and AA-5B aircraft are as follows:

| | <u>AA-5</u> | <u>AA-5A</u> | <u>AA-5B</u> |
|------------------------------------|---|---|---|
| <u>FAA Type Certificate</u> | A16EA | A16EA | A16EA |
| <u>Gross Weight (Normal Cat.)</u> | 2200 lbs. | 2200 lbs. | 2400 lbs. |
| <u>Gross Weight (Utility Cat.)</u> | 1850 lbs. | 1850 lbs. | 2050 lbs. |
| <u>Fuel Capacity</u> | 37 gal. | 37 gal. (51 Opt.) | 51 gal. |
| <u>Oil Capacity</u> | 8 qts. | 8 qts. | 8 qts. |
| <u>Engine</u> | Lycoming 0-320-E2G 150 HP @ 2700 RPM | Lycoming 0-320-E2G 150 HP @ 2700 RPM | Lycoming 0-360-A4K 180 HP @ 2700 RPM |
| <u>Propeller (Fixed Pitch)</u> | McCauley 73" Dia. | McCauley 73" Dia. | McCauley 75" Dia. |
| <u>Spinner</u> | Req'd Equipment | Req'd Equipment | Req'd Equipment |
| <u>Length</u> | 22' | 22' | 22' |
| <u>Height</u> | 8' (1972 & 1973) 7'10" (1974 & 1975) | 7'-8" | 7'-8" |
| <u>Wings:</u> | | | |
| Span | 31'-6" | 31'-6" | 31'-6" |
| Dihedral | 5° | 5° | 5° |
| Incidence | 1° 25' | 1° 25' | 1° 25' |
| Aileron Travel (Up) (Dn) | 15° +2° -0° 7 ½° + 2 ½° - 0° | 15° +2° -0° 7 ½° + 2 ½° - 0° | 15° +2° -0° 7 ½° + 2 ½° - 0° |
| Flap Travel | 30° ± 3° | 45° ± 2° | 45° ± 2° |

**AA-5 SERIES
MAINTENANCE MANUAL**

| | AA-5 | AA-5A | AA-5B |
|------------------------------|--------------------------|--------------------------|--------------------------|
| Max Difference Between Flaps | 1° | 1° | 1° |
| <u>Empennage:</u> | | | |
| Horizontal Tail Incidence | -3° | 0° | 0° |
| Vertical Tail Offset | 0° | 0° | 0° |
| Elevator Travel (Up) | 30° ± 2° | 24° ± 2° | 24° ± 2° |
| (Dn) | 20° ± 2° | 17° ± 2° | 17° ± 2° |
| Rudder Travel (Lt & Rt) | 25° ± 2° | 25° ± 2° | 25° ± 2° |
| Trim Tab Travel (Up) | 16° ± 2° | 14° ± 3° | 14° ± 3° |
| (Dn) | 19° ± 2° | 30° ± 1° | 30° ± 1° |
| <u>Main Wheel Tire</u> | | | |
| | 6.00 x 6 4 ply rating | 6.00 x 6 4 ply rating | 6.00 x 6 6 ply rating |
| Pressure | 24 psi | 24 psi | 35 psi |
| <u>Nose Wheel Tire</u> | | | |
| | 5.00 x 5 4 ply rating | 5.00 x 5 4 ply rating | 5.00 x 5 4 ply rating |
| Pressure | 21 psi | 21 psi | 25 psi |

**AA-5 SERIES
MAINTENANCE MANUAL**

CHAPTER 7
LIFTING & JACKING
TABLE OF CONTENTS

| <u>NUMBER</u> | | <u>PAGE</u> |
|----------------------|---------------------------------------|--------------------|
| 7-0 | LIFTING AND JACKING POINTS | |
| | General | 1 |
| | Lifting and Jacking Points | 1 |
| 7-1-1 | LIFTING AND JACKING PROCEDURES | |
| | General | 1 |
| | Lifting Procedures | 1 |
| | Jacking Procedures | 1 |

**AA-5 SERIES
MAINTENANCE MANUAL**

LIFTING AND JACKING POINTS

1. General

This section identifies and locates on illustrations those points that may be used when lifting or jacking of the aircraft is required. Reference is also made to Paragraph 7-3 to indicate what special lifting, jacking, or shoring equipment may be used at each lifting or jacking point.

2. Lifting and Jacking Points

The lifting and jacking points for the AA-5, AA-5A, and AA-5B aircraft are shown in Figure 1.

AA-5 SERIES
MAINTENANCE MANUAL

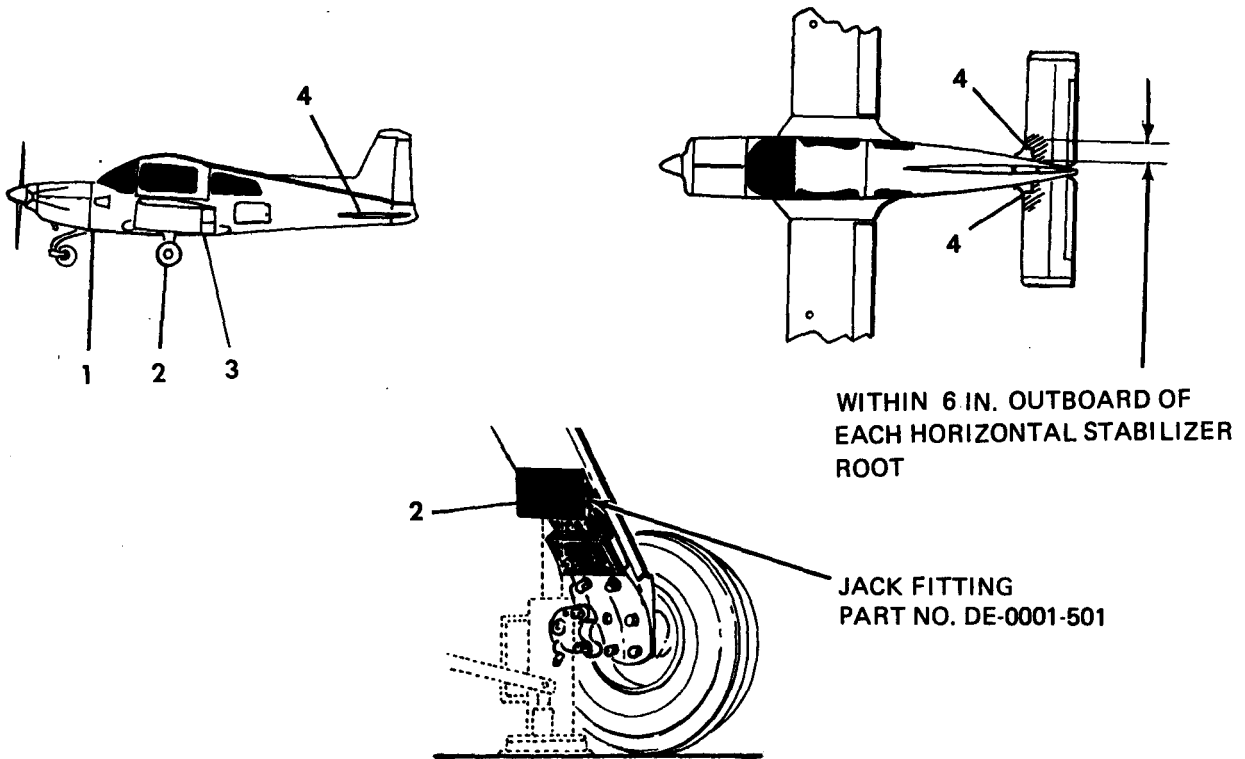

1. Front Lifting Point — Fuselage Station 51.

NOTE: The jack fitting is not permanently installed. It is a “slip on” fitting, that can be used only on AA-5 aircraft manufactured prior to 1975.

2. Landing Gear Jacking Point — On Gear Strut of Aircraft with Jack Fitting (Part No. DE-0001-501) installed.
3. Aft Lifting Point — Fuselage Station 125.
4. Empennage Lifting Point — Within 6 inches of the horizontal stabilizer root.

Lifting and Jacking Points
Figure 1

LIFTING AND JACKING PROCEDURES

1. General

This section provides the recommended procedures for lifting and jacking the aircraft to accomplish maintenance and inspection procedures. Since lifting and jacking of aircraft can be accomplished by a wide variety of procedures, depending primarily upon the equipment available, these procedures provide general instructions that can be modified as necessary by the user, in light of his equipment availability.

2. Lifting Procedures

A. Lifting the nose landing gear is accomplished as follows:

CAUTION: IF A STAND IS USED TO SUPPORT THE FORWARD FUSELAGE WHEN THE NOSE GEAR IS LIFTED, ENSURE THAT THE BEARING SURFACE OF THE STAND EXTENDS THE WIDTH OF THE FUSELAGE AND THAT THE SURFACE IS AT LEAST 4 INCHES WIDE. THE LOAD BEARING SURFACE SHOULD BE COVERED WITH PADDING OR HARD FOAM RUBBER. THE STAND MUST BE CAPABLE OF SUPPORTING 1500 POUNDS.

(1) Engage the parking brake or place chocks around both main landing gear.

CAUTION: WHEN THE NOSE OF THE AIRCRAFT IS RAISED, ENSURE THAT THE TRIM TAB AND FUSELAGE DO NOT STRIKE THE GROUND. DO NOT PRESS DOWN ON THE OUTBOARD END OF THE HORIZONTAL STABILIZER.

(2) Press down on the horizontal stabilizer in the area of the stabilizer front spar, and within six inches of the fuselage. (See Figure 1, Section 7-0.)

(3) While holding the aircraft tail down, slide a stand (approximately 30 inches high) beneath the Fuselage Station 51, immediately behind the torque tube center bearing mounting bolts.

(4) Slowly lower the nose on to the stand by releasing downward pressure on the horizontal stabilizer.

B. Lifting the entire aircraft is accomplished as follows:

(1) Lift the aircraft nose and place the forward stand as described in Paragraph A.

(2) Secure a second stand of the same height and load-bearing capability as the one under the forward fuselage.

NOTE: The aft Fuselage requires a lifting force of approximately 500 pounds to lift it sufficiently for the stand to be placed under the fuselage.

(3) Manually lift the aft fuselage, and slide the stand under the fuselage at Fuselage Station 125.

(4) Lower the aircraft on to the stand.

3. Jacking Procedures

A. Jacking of the main landing gear can be accomplished on aircraft manufactured prior to 1975 by installing for use with a small jack, jack fittings (Part No. DE-0001-501). Jacking is done by placing a jack, as shown in Figure 1, Section 7-0, and jacking the aircraft up. If jack fittings are not used, the aircraft can be jacked as shown in Figure 1.

**AA-5 SERIES
MAINTENANCE MANUAL**

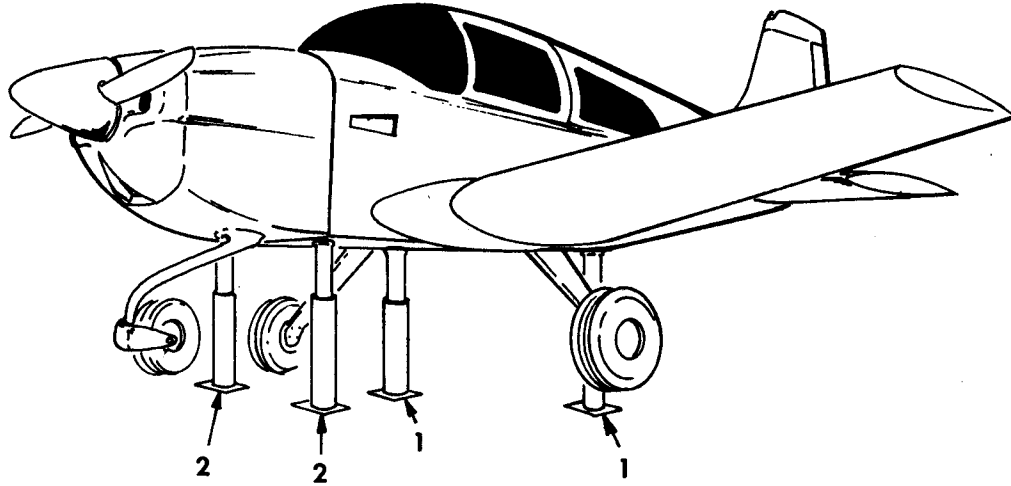

1. Place jacks beneath aft fuselage at Fuselage Station 125 on each side of fuselage.
2. Place jacks beneath fuselage at Fuselage Station 51, on each side of fuselage.

**Jacking Arrangement
Figure 1 /**

**AA-5 SERIES
MAINTENANCE MANUAL**

CHAPTER 8
LEVELING & WEIGHING
TABLE OF CONTENTS

| <u>NUMBER</u> | | <u>PAGE</u> |
|---------------|-----------------------------------|-------------|
| 8-0 | AIRCRAFT PREPARATION FOR WEIGHING | |
| | General | 1 |
| | Preparation Procedure | 1 |
| 8-1-1 | LEVELING | |
| | General | 1 |
| | Leveling Procedure | 1 |
| 8-2-1 | WEIGHING | |
| | General | 1 |
| | Weighing Procedure | 1 |
| 8-3-1 | MEASURING ARM | |
| | General | 1 |
| | Measuring Procedure | 1 |
| 8-4-1 | COMPUTING CENTER OF GRAVITY | |
| | General | 1 |
| | Computation Procedure | 1 |

AIRCRAFT PREPARATION FOR WEIGHING

1. General

This section contains the procedure for determining the basic empty weight and moment of the aircraft. Sample forms and the corresponding procedures for their use are provided to enable a rapid calculation of the weight and moment for various operations. A comprehensive list of all available equipment for the aircraft is also provided.

It should be remembered that specific information on weight, arm, moment, and installed equipment for this aircraft can only be found in the appropriate weight and balance records carried in the aircraft.

2. Preparation Procedures

Prepare the aircraft for leveling and weighing as follows:

- A. Inflate all tires to recommended operating pressure. (Refer to Chapter 12.)
- B. Drain all fuel from the tanks and fuel system. (Refer to Chapter 28.)
- C. Drain all oil from the oil system. (Refer to Chapter 12.)
- D. Move sliding seats to center of travel position.
- E. Raise flaps to fully retracted position.
- F. Place all controls in neutral position.
- G. Ensure that all objects not a part of the aircraft or its accessories are removed from the aircraft.
- H. Slide canopy to provide a six inch opening between canopy and windshield.

LEVELING

1. General

Normally, aircraft leveling is accomplished in conjunction with aircraft weighing. When this is the case, the aircraft should be mounted on the scales prior to leveling.

When leveling is done in conjunction with some maintenance procedure (fuel gage calibration, etc.), the aircraft should be parked on a level surface.

2. Leveling Procedure

Level the aircraft as follows:

- A. Place under each wheel (minimum capacity 1500 pounds for nose wheel and 1000 pounds capacity for main wheels), with a 1 inch thick wooden block between each wheel and the scale.
- B. Place carpenter's levels on canopy track as shown in Figure 1.
- C. Level aircraft both laterally and longitudinally by deflating one or two tires until the bubbles in the level center.

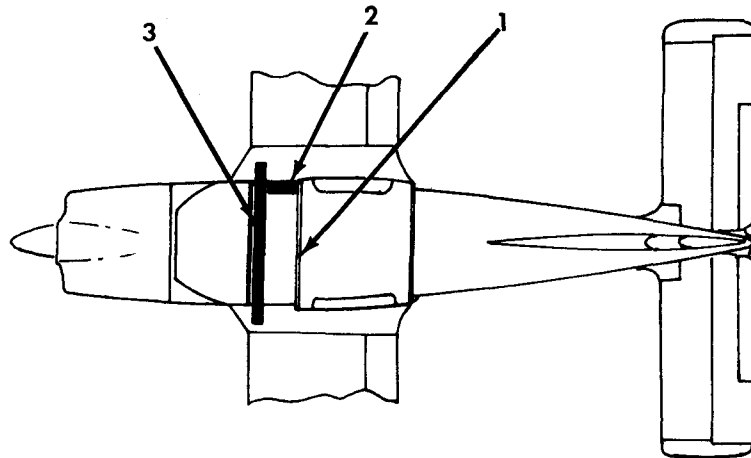

- (1) Open the canopy approximately six inches.
- (2) Level aircraft longitudinally by placing a short spirit level on the right canopy rail forward of the pilot's seat, and deflating nose tire or main gear tires to center the bubble.
- (3) Level the aircraft laterally by placing a four foot carpenter's level across the canopy rails at windshield and differentially deflating main gear tires to center the bubble.

Aircraft Leveling
Figure 1

AA-5 SERIES
MAINTENANCE MANUAL

WEIGHING

1. General

Aircraft weighing should be done in an area such as a hangar where wind or other disturbances do not cause inaccurate scale readings. The scales used should be properly calibrated and of sufficient capacity to support the aircraft.

2. Weighing Procedure

Weigh the aircraft as follows:

- A. Remove the levels, close and lock the canopy.
- B. With aircraft level and brakes released, record the weight shown on each scale as shown in Figure 1.
- C. Deduct tare (chocks, etc.), if any, from the scale readings and record the result in the weighing form.

**AA-5 SERIES
MAINTENANCE MANUAL**

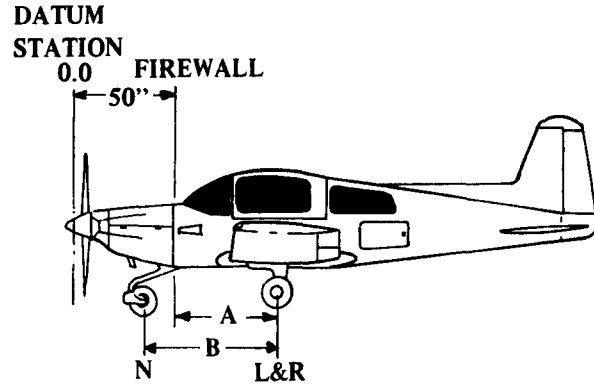

| Scale Position | Scale Reading | Tare | Symbol | Net Weight |
|---------------------|---------------|------|--------|------------|
| Left Wheel | | | L | |
| Right Wheel | | | R | |
| Nose Wheel | | | N | |
| Total of Net Weight | | | W | |

Calculate Arm (in inches) as follows:

NOTE

- (50 + A) = Main Landing Gear Arm (in Inches)
- 50 - (B - A) = Nose Landing Gear Arm (in Inches)
- L = Weight of Left Main Landing Gear (in Pounds)
- R = Weight of Right Main Landing Gear (in Pounds)
- N = Weight of Nose Landing Gear (in Pounds)

$$\text{C.G. Arm} = \frac{[(50 + A)(L + R)] + [50 - (B - A)] N}{L + R + N}$$

| Item | Weight | C.G. Arm | Moment/ 1000 Lbs. In. |
|--------------------------------------|--------|----------|--------------------------|
| Aircraft Net Weight (W) | | | |
| Oil, 8 Qt. at 1.875 Lb./Qt. | 15.0 | 32.0 | .48 |
| Unusable Fuel 1.6 Gal. at 6 Lb./Gal. | 9.6 | 94.8 | .91 |
| Equipment Changes | | | |
| Aircraft Basic Empty Weight | | | |

Sample Aircraft Weighing
Figure 1

MEASURING ARM

1. General

The following procedures must be performed carefully in order to obtain the accuracy required for proper center of gravity computation. When performing these measurements, ensure that the string is stretched tight enough to prevent deflection during measurement, and that the aircraft is level during the measurements.

2. Measuring Procedure

Measure the arm as follows:

A. Obtain measurement A (Section 8-2-1, Figure 1) as follows:

- (1) Stretch a string laterally across the aircraft from the axle center of one main landing gear to the axle center of the other.
- (2) Connect a plumb bob such that it hangs from the centerline of the engine firewall to the floor.
- (3) Using a tape, measure the distance along the centerline of the aircraft from the plumb bob to the string stretched between the main landing gear.
- (4) Record measurement A in the Weight Form (Section 8-2-1, Figure 1).

B. Obtain measurement B (Section 8-2-1, Figure 1) as follows:

- (1) Ensure that the nosewheel is set straight along the centerline of the aircraft.
- (2) Using a tape, measure from the center of the nose gear axle to the string stretched between the main landing gear wheels.
- (3) Record measurement B in the Weight Form (Section 8-2-1, Figure 1).

COMPUTING CENTER OF GRAVITY

1. General

The following computation is performed in the sample form shown in Section 8-2-1, Figure 1. This computation determines the aircraft basic empty weight moment.

2. Computation Procedures

Perform the computation as follows:

- A. Using the weights previously recorded, calculate the aircrafts net weight (W), per Section 8-2-1, Figure 1.
- B. Using the weights and measurements previously recorded, calculate the C.G. Arm according to the formula in Section 8-2-1, Figure 1.
- C. Enter the aircrafts net weight (W) and C.G. Arm obtained in Steps A and B in the Aircraft Basic Empty Weight Form at the bottom of Section 8-2-1, Figure 1.
- D. Obtain moment by multiplying weight times C.G. Arm and dividing by 1000. Enter moment in the appropriate column.
- E. Add the entries in the Weight column to obtain the AIRCRAFT BASIC EMPTY WEIGHT.
- F. Add the entries in the MOMENT/1000 Lbs. In. column to obtain the AIRCRAFT BASIC EMPTY WEIGHT MOMENT.

AA-5 SERIES
MAINTENANCE MANUAL

CHAPTER 9

TOWING & TAXIING

TABLE OF CONTENTS

| <u>NUMBER</u> | | <u>PAGE</u> |
|---------------|-------------------|-------------|
| 9-0 | TOWING | |
| | General | 1 |
| | Towing Procedures | 1 |
| 9-1-1 | TAXIING | |
| | General | 1 |
| | Taxiing Technique | 1 |

TOWING

1. General

This section provides the procedures recommended for manual towing of the AA-5, AA-5A, and AA-5B aircraft.

2. Towing Procedures

CAUTION: USING THE PROPELLER FOR GROUND HANDLING COULD RESULT IN SERIOUS DAMAGE, ESPECIALLY IF PRESSURE IS EXERTED ON THE OUTER ENDS. DO NOT ATTEMPT TO PUSH THE AIRCRAFT BACKWARD WITHOUT THE AID OF A TOW BAR. THIS ACTION COULD RESULT IN THE NOSE WHEEL PIVOTING ABRUPTLY AND DAMAGING THE NOSE WHEEL STOPS.

Towing of the aircraft should be accomplished by use of the nose gear tow bar (Part No. 5804052-501), as follows:

- A. Extend the tow bar by pulling the handle out and rotating it to engage the lock as shown in Figure 1.
- B. Open the jaws of the tow bar by pulling the latch arm forward as shown in Figure 1.

CAUTION: WHEN USING TOW BAR, EXERCISE CAUTION SO THAT FINISH ON NOSE WHEEL FAIRING IS NOT DAMAGED.

- C. Place tow bar sockets over tow bolts on nose gear and close latch by pushing latch arm aft, as shown in Figure 1.
- D. Tow aircraft by pulling or pushing tow bar handle.

AA-5 SERIES
MAINTENANCE MANUAL

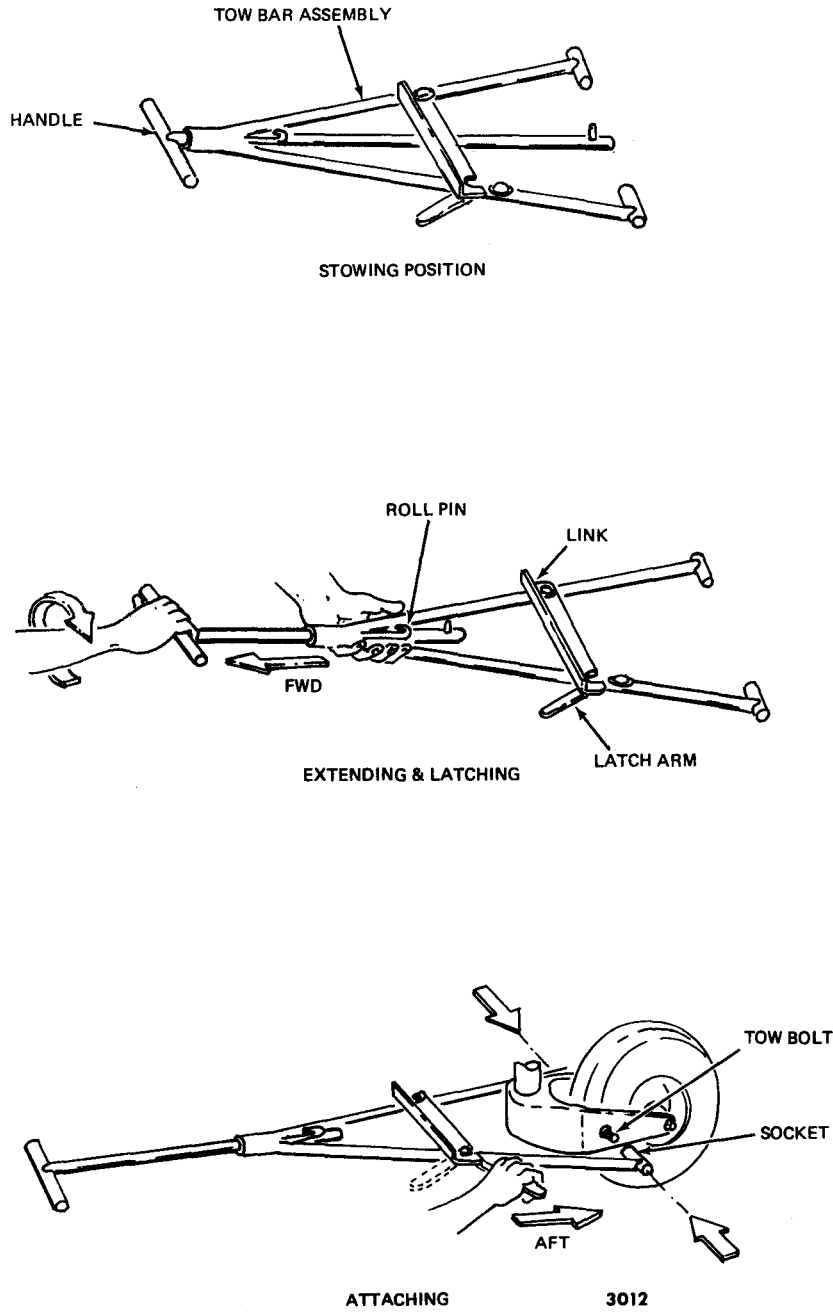

Tow Bar Usage
Figure 1

AA-5 SERIES
MAINTENANCE MANUAL

TAXIING

1. General

Taxiing of the AA-5, AA-5 A, or AA-5B aircraft is accomplished in a similar manner. Since the rudder controls on these aircraft are not directly coupled to the nosewheel, directional control during taxiing is maintained by use of differential braking.

2. Taxiing Technique

All taxiing should be done at slow speed, and the controls should be positioned such that the affects of gusty wind are minimized. (See Taxiing Diagram, Figure 1).

Taxiing should not be attempted in strong crosswinds. If taxiing is necessary, the use of "wing walkers" is recommended.

Taxiing over loose gravel or cinders should be done at low engine speed to minimize damage to the propeller tips horizontal surfaces and landing gear due to stone damage.

**AA-5 SERIES
MAINTENANCE MANUAL**

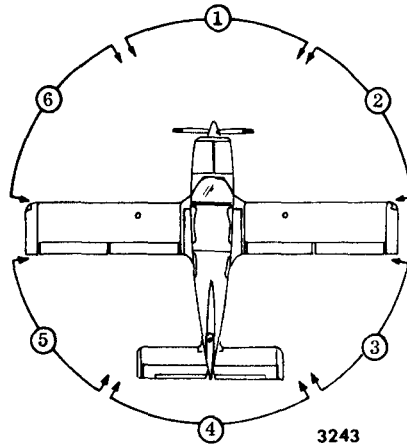

| NUMBER | WIND DIRECTION | CONTROL | POSITION |
|---------------|-----------------------|----------------|-----------------|
| (1) | FWD | WHEEL NEUTRAL | BACK |
| (2) | FWD RH QUARTER | WHEEL RIGHT | BACK |
| (3) | AFT RH QUARTER | WHEEL LEFT | FORWARD |
| (4) | AFT | WHEEL NEUTRAL | FORWARD |
| (5) | AFT LH QUARTER | WHEEL RIGHT | FORWARD |
| (6) | FWD LH QUARTER | WHEEL LEFT | BACK |

**Taxiing Diagram
Figure 2**

**AA-5 SERIES
MAINTENANCE MANUAL**

CHAPTER 10
PARKING AND MOORING
TABLE OF CONTENTS

| <u>NUMBER</u> | | <u>PAGE</u> |
|----------------------|-----------------------------------|--------------------|
| 10-0 | PARKING | |
| | General | 1 |
| | Parking Precautions | 1 |
| | Parking Procedures | 1 |
| 10-1-1 | MOORING | |
| | General | 1 |
| | Normal Tiedown | 1 |
| | Severe Weather Precautions | 1 |

AA-5 SERIES
MAINTENANCE MANUAL

PARKING

1. General

This section provides the procedures recommended to park the aircraft so that the likelihood of ground damage is minimized. Parking is defined as leaving the aircraft unattended for a short period of time.

2. Parking Precautions

- A. Do not park the aircraft in an area subject to prop or jet wash.
- B. Do not park the the aircraft if moderate to high winds or storms are anticipated. Moor the aircraft as described in Section 10-1-1.
- C. If heavy braking was applied during landing, allow the brakes to cool before setting the parking brake.
- D. Do not set the parking brake when the ambient temperature is near or below freezing. Accumulated moisture may freeze in the brakes, preventing them from releasing.

CAUTION: WHEN CHOCKING WHEELS, ENSURE THAT THE CHOCKS USED ARE NOT LARGE ENOUGH TO COME IN CONTACT WITH THE WHEEL FAIRINGS. USE OF CHOCKS THAT ARE TOO LARGE MAY DAMAGE FAIRINGS.

3. Parking Procedures

- A. Choose an area free from prop or jet wash.
- B. Head aircraft into wind and set parking brake.
- C. Install control lock.

MOORING

1. General

This section provides the procedures recommended for a normal tie-down of the aircraft, and special precautions that may be taken to minimize the likelihood of damage during severe weather.

2. Normal Tie-Down

Proper tie-down procedure is the best precaution against damage to the parked aircraft by gusty or strong winds. To tie-down the aircraft securely, proceed as follows:

- A. Chock all wheels and install the control wheel lock.

CAUTION: WHEN CHOCKING WHEELS, ENSURE THAT THE CHOCKS USED ARE NOT
LARGE ENOUGH TO COME IN CONTACT WITH THE WHEEL FAIRINGS.
USE OF CHOCKS THAT ARE TOO LARGE MAY DAMAGE FAIRINGS.

- B. Tie sufficiently strong ropes or chains to the wing and tail tie-down fittings and secure each rope to a ramp tie-down.

- C. Ensure that the canopy is closed and latched.

3. Severe Weather Precautions

When it is necessary to moor the aircraft during periods when severe weather is anticipated, the following precautions (in addition to the steps in Section 2) may be employed:

- A. Ensure that the aircraft is positioned so that it is headed directly into the wind.

- B. When manila rope is used for mooring ensure that the rope has sufficient slack to compensate for shrinkage when the rope gets wet, and subsequently dries.

**AA-5 SERIES
MAINTENANCE MANUAL**

CHAPTER 11

PLACARDS AND MARKINGS

TABLE OF CONTENTS

| <u>NUMBER</u> | | <u>PAGE</u> |
|---------------|-----------------------|-------------|
| 11-0 | PLACARDS AND MARKINGS | |
| | General | 1 |
| | Placard Locations | 1 |
| 11-1-1 | EXTERIOR PLACARDS | 1 |
| 11-2-1 | INTERIOR PLACARDS | 1 |

**AA-5 SERIES
MAINTENANCE MANUAL**

PLACARDS AND MARKINGS

1. **General**

This Chapter contains information relating to placards used on the AA-5, AA-5A and AA-5B aircraft which define aircraft limitations and/or flight safety data required by FAA regulations to be properly affixed to the aircraft. Also shown in this chapter are placards which provide the pilot, passengers and maintenance personnel with aircraft operational data.

2. **Placard Locations**

The appearance, content and location of all placards are contained in Figure 1 and Figure 2. The exterior placards are shown in Figure 1, while the interior placards are shown in Figure 2.

Located on each side of vertical stabilizer.

GRUMMAN AMERICAN

AA-5, AA-5A and AA-5B

Located on each side of aft fuselage aft of rear window.



AA-5B

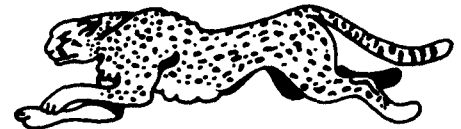

AA-5A

Located on left rear fuselage below horizontal stabilizer.

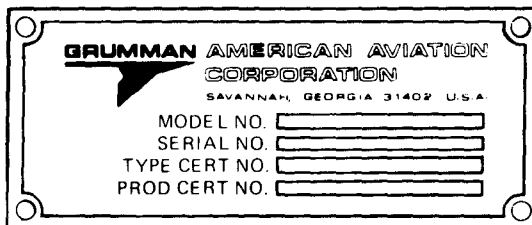

AA-5, AA-5A and AA-5B

Located on firewall

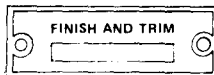

AA-5, AA-5A and AA-5B

Located on firewall.



AA5-0001 thru 0834
AA5A-0001 and Subsequent
AA5B-0001 and Subsequent

Exterior Placards
Figure 1 (Sheet 1 of 4)

**AA-5 SERIES
MAINTENANCE MANUAL**

Located on inside of engine cowling.

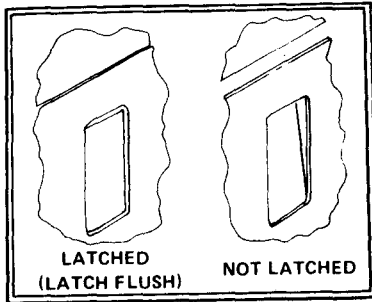

AA5-0641 thru 0834
AA5A-0001 and Subsequent
AA5B-0001 and Subsequent

Located on left and right side of fuselage forward of wing root.



AA5-0001 thru 0834
AA5A-0001 and Subsequent
AA5B-0001 and Subsequent

Located adjacent to auxiliary power plug (if installed)

CAUTION: 12 VOLT
D.C. ONLY, MASTER
SW. MUST BE OFF

Located on wing outer ribs (if strobe lights are installed)

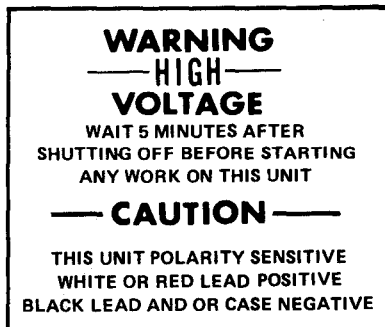

Exterior Placards
Figure 1 (Sheet 2 of 4)

**AA-5 SERIES
MAINTENANCE MANUAL**

Located adjacent to fuel tank caps

**FUEL
MIN 80/87 OCT
19 U.S. GAL. CAP**

**AA5-0001 thru 0834
AA5A-0001 and Subsequent (standard tanks)**

**FUEL
MIN 80/87 OCT.
26.3 U.S. GAL. TOTAL CAP.
19.0 U.S. GAL. TO TAB**

AA5A-0001 and Subsequent (long-range tanks)

**FUEL
MIN 100/130 OCT
26.3 U.S. GAL. TOTAL CAP.
19.0 U.S. GAL. TO TAB**

AA5B-0001 and Subsequent

Located on left and right wing at fuel filler cap



AA5B-0022 and Subsequent

Located on right wing leading edge

**DO NOT PAINT
VANE OR SLOT**

Located on left and right wing root and flaps (2 places on each wing)

NO STEP

**Exterior Placards
Figure 1 (Sheet 3 of 4)**

**AA-5 SERIES
MAINTENANCE MANUAL**

Located at either canopy track on fuselage

LEVEL AIRPLANE HERE

AA-5, AA-5A and AA-5B

Located on left and right side of canopy (exterior).

NO PUSH
CLOSE CANOPY WITH
LATCH HANDLE

AA5-0001 thru 0834
AA5A-0001 and Subsequent
AA5B-0001 and Subsequent

Located on aft fuselage above left horizontal stabilizer

EMERGENCY ACCESS - CRASH LOCATOR BCN:
PROTECT HANDS, PULL AND RIP COVER OPEN HERE,
MANUALLY ACTIVATE THE TRANSMITTER-BCN BY
PUSHING THE TOGGLE SWITCH TOWARD THE
TOP OF THE FUSELAGE TO THE ON POSITION.



AA5-0525 thru 0834 (if installed)
AA5A-0001 and Subsequent
AA5B-0001 and Subsequent

Located on bracket attached to battery box.

H METER
DOME LT.
+
5
+
CLOCK

AA5-0001 thru 0834
AA5A-0001 and Subsequent
AA5B-0001 and Subsequent

Located on each side of forward fuselage below lower aft corner of windshield.



AA-5A and AA-5B

Exterior Placards
Figure 1 (Sheet 4 of 4)

Located on left hand rail

THIS AIRPLANE MUST BE OPERATED AS A NORMAL OR UTILITY CATEGORY AIRPLANE IN COMPLIANCE WITH THE OPERATING LIMITATIONS STATED IN FORM OF PLACARDS, MARKINGS AND MANUALS.

NORMAL CATEGORY
 MAXIMUM DESIGN WEIGHT 2200 LBS
 DESIGN MANEUVERING SPEED V_A 122 MPH CAS
 FLIGHT LOAD FACTORS FLAPS UP +3.8 -1.52 FLAPS DOWN +3.5
 NO ACROBATIC MANEUVERS, INCLUDING SPINS, APPROVED.

UTILITY CATEGORY
 MAXIMUM DESIGN WEIGHT 1850 LBS
 DESIGN MANEUVERING SPEED V_A 122 MPH CAS
 FLIGHT LOAD FACTORS FLAPS UP +4.4 -1.76 FLAPS DOWN +3.5
 REAR SEAT MUST NOT BE OCCUPIED

—ACROBATIC MANEUVERS ARE LIMITED TO THE FOLLOWING:—

| <u>MANEUVER</u> | <u>ENTRY SPEED - CAS</u> |
|-----------------------------------|--------------------------|
| CHANDELLES | 122 MPH |
| LAZY EIGHTS | 122 MPH |
| STEEP TURNS | 122 MPH |
| STALLS (EXCEPT WHIP STALLS) | SLOW DECELERATION |
| SPINS PROHIBITED | |

MAXIMUM ALTITUDE LOSS IN STALL 350 FEET
 DEMONSTRATED CROSSWIND VELOCITY 18 MPH

THIS AIRPLANE NOT APPROVED FOR FLIGHT IN ICING CONDITIONS.

THIS AIRPLANE IS CERTIFIED FOR THE FOLLOWING OPERATIONS AS OF DATE OF ORIGINAL AIRWORTHINESS CERTIFICATE, IFR, VFR, DAY, NIGHT. REFER TO WEIGHT AND BALANCE DATA FOR LOADING INSTRUCTIONS. READ FUEL GAUGES IN LEVEL FLIGHT ONLY. FOR NORMAL OPERATION - MAINTAIN FUEL BALANCE.

AA5-0001 thru 0834

Located on left hand rail

THIS AIRPLANE MUST BE OPERATED AS A NORMAL OR UTILITY CATEGORY AIRPLANE IN COMPLIANCE WITH THE OPERATING LIMITATIONS STATED IN FORM OF PLACARDS, MARKINGS AND MANUALS.

NORMAL CATEGORY
 MAXIMUM DESIGN WEIGHT 2200 LBS
 DESIGN MANEUVERING SPEED V_A 122 MPH CAS
 FLIGHT LOAD FACTORS FLAPS UP +3.8 -1.52 FLAPS DOWN +3.5
 NO ACROBATIC MANEUVERS, INCLUDING SPINS, APPROVED

UTILITY CATEGORY
 MAXIMUM DESIGN WEIGHT 1850 LBS
 DESIGN MANEUVERING SPEED V_A 122 MPH CAS
 FLIGHT LOAD FACTORS FLAPS UP +4.4 -1.76 FLAPS DOWN +3.5
 REAR SEAT MUST NOT BE OCCUPIED

—AEROBATIC MANEUVERS ARE LIMITED TO THE FOLLOWING:—

| <u>MANEUVER</u> | <u>ENTRY SPEED - CAS</u> |
|-----------------------------------|--------------------------|
| CHANDELLES | 122 MPH |
| LAZY EIGHTS | 122 MPH |
| STEEP TURNS | 122 MPH |
| STALLS (EXCEPT WHIP STALLS) | SLOW DECELERATION |
| SPINS PROHIBITED | |

MAXIMUM ALTITUDE LOSS IN STALL 350 FEET
 DEMONSTRATED CROSSWIND VELOCITY 18 MPH

THIS AIRPLANE NOT APPROVED FOR FLIGHT IN ICING CONDITIONS

THIS AIRPLANE IS CERTIFIED FOR THE FOLLOWING OPERATIONS: IFR, VFR, DAY, NIGHT, WHEN PROPERLY EQUIPPED PER FAR 91. REFER TO WEIGHT AND BALANCE DATA LOADING INSTRUCTIONS. READ FUEL GAUGES IN LEVEL FLIGHT ONLY. FOR NORMAL OPERATION - MAINTAIN FUEL BALANCE.

AA5A-0001 thru 0282

**AA-5 SERIES
MAINTENANCE MANUAL**

Located on left hand rail

THIS AIRPLANE MUST BE OPERATED AS A NORMAL OR UTILITY CATEGORY AIRPLANE IN COMPLIANCE WITH THE OPERATING LIMITATIONS STATED IN FORM OF PLACARDS, MARKINGS, AND MANUALS.

NORMAL CATEGORY
 MAXIMUM DESIGN WEIGHT 2200 LBS
 DESIGN MANEUVERING SPEED V_A 106 KNOTS CAS
 FLIGHT LOAD FACTORS FLAPS UP +3.8 -1.52 FLAPS DOWN +3.5
 NO AEROBATIC MANEUVERS, INCLUDING SPINS, APPROVED

UTILITY CATEGORY
 MAXIMUM DESIGN WEIGHT 1850 LBS
 DESIGN MANEUVERING SPEED V_A 106 KNOTS CAS
 FLIGHT LOAD FACTORS FLAPS UP +4.4 -1.76 FLAPS DOWN +3.5
 REAR SEAT MUST NOT BE OCCUPIED

— ACROBATIC MANEUVERS LIMITED TO THE FOLLOWING —

| <u>MANEUVER</u> | <u>ENTRY SPEED - CAS</u> |
|-----------------------------------|--------------------------|
| CHANDELLES | 106 KNOTS |
| LAZY EIGHTS | 106 KNOTS |
| STEEP TURNS | 106 KNOTS |
| STALLS (EXCEPT WHIP STALLS) | SLOW DECELERATION |
| SPINS PROHIBITED | |

MAXIMUM ALTITUDE LOSS IN STALL 350 FEET
 DEMONSTRATED CROSSWIND VELOCITY 16 KNOTS

THIS AIRPLANE NOT APPROVED FOR FLIGHT IN ICING CONDITIONS.

THIS AIRPLANE IS CERTIFIED FOR THE FOLLOWING OPERATIONS: IFR, VFR, DAY, NIGHT, WHEN PROPERLY EQUIPPED PER FAR 91. REFER TO WEIGHT AND BALANCE DATA FOR LANDING INSTRUCTIONS. READ FUEL GAUGES IN LEVEL FLIGHT ONLY. FOR NORMAL OPERATION - MAINTAIN FUEL BALANCE.

AA5A-0283 and Subsequent

Located on left hand rail

THIS AIRPLANE MUST BE OPERATED AS A NORMAL OR UTILITY CATEGORY AIRPLANE IN COMPLIANCE WITH THE OPERATING LIMITATIONS STATED IN FORM OF PLACARDS, MARKINGS AND MANUALS.

NORMAL CATEGORY
 MAXIMUM DESIGN WEIGHT 2400 LBS
 DESIGN MANEUVERING SPEED V_A 130 MPH CAS
 FLIGHT LOAD FACTORS FLAPS UP +3.8 -1.52 FLAPS DOWN +3.5
 NO AEROBATIC MANEUVERS, INCLUDING SPINS, APPROVED.

UTILITY CATEGORY
 MAXIMUM DESIGN WEIGHT 2050 LBS
 DESIGN MANEUVERING SPEED V_A 130 MPH CAS
 FLIGHT LOAD FACTORS FLAPS UP +4.4 -1.76 FLAPS DOWN +3.5
 REAR SEAT MUST NOT BE OCCUPIED

ACROBATIC MANEUVERING LIMITED TO THE FOLLOWING

| <u>MANEUVER</u> | <u>ENTRY SPEED - CAS</u> |
|-----------------------------------|--------------------------|
| CHANDELLES | 130 MPH |
| LAZY EIGHTS | 130 MPH |
| STEEP TURNS | 130 MPH |
| STALLS (EXCEPT WHIP STALLS) | SLOW DECELERATION |
| SPINS PROHIBITED | |

MAXIMUM ALTITUDE LOSS IN STALL 350 FEET
 DEMONSTRATED CROSSWIND VELOCITY 18 MPH

THIS AIRPLANE NOT APPROVED FOR FLIGHT IN ICING CONDITIONS.

THIS AIRPLANE IS CERTIFIED FOR THE FOLLOWING OPERATIONS: IFR, VFR, DAY, NIGHT, WHEN PROPERLY EQUIPPED PER FAR 91. REFER TO WEIGHT AND BALANCE DATA FOR LANDING INSTRUCTIONS. READ FUEL GAUGES IN LEVEL FLIGHT ONLY. FOR NORMAL OPERATION - MAINTAIN FUEL BALANCE.

AA5B-0001 thru 0399

Located on left hand rail

THIS AIRPLANE MUST BE OPERATED AS A NORMAL OR UTILITY CATEGORY AIRPLANE IN COMPLIANCE WITH THE OPERATING LIMITATIONS STATED IN FORM OF PLACARDS, MARKINGS, AND MANUALS

NORMAL CATEGORY
 MAXIMUM DESIGN WEIGHT2400 LBS
 DESIGN MANEUVERING SPEED V_A 113 KNOTS CAS
 FLIGHT LOAD FACTORSFLAPS UP +3.8 -1.52 FLAPS DOWN +3.5
 NO ACROBATIC MANEUVERS, INCLUDING SPINS, APPROVED.

UTILITY CATEGORY
 MAXIMUM DESIGN WEIGHT2050 LBS
 DESIGN MANEUVERING SPEED V_A 113 KNOTS CAS
 FLIGHT LOAD FACTORSFLAPS UP +4.4 -1.76 FLAPS DOWN +3.5
 REAR SEAT MUST NOT BE OCCUPIED.

ACROBATIC MANEUVERS LIMITED TO THE FOLLOWING

| MANEUVER | ENTRY SPEED - CAS |
|-----------------------------------|-------------------|
| CHANDELLES | 113 KNOTS |
| LAZY EIGHTS | 113 KNOTS |
| STEEP TURNS | 113 KNOTS |
| STALLS (EXCEPT WHIP STALLS) | SLOW DECELERATION |

SPINS PROHIBITED.

MAXIMUM ALTITUDE LOSS IN STALL 350 FEET
 DEMONSTRATED CROSSWIND VELOCITY 16 KNOTS

THIS AIRPLANE NOT APPROVED FOR FLIGHT IN ICING CONDITIONS.

THIS AIRPLANE IS CERTIFIED FOR FOR THE FOLLOWING OPERATIONS: IFR, VFR, DAY, NIGHT, WHEN PROPERLY EQUIPPED PER FAR 91. REFER TO WEIGHT AND BALANCE DATA FOR LOADING INSTRUCTIONS. READ FUEL GAUGES IN LEVEL FLIGHT ONLY. FOR NORMAL OPERATION - MAINTAIN FUEL BALANCE.

AA5B-0400 and Subsequent

Located inside canopy rail, left side

↑ 130 MPH MAX WITH CANOPY OPEN TO HERE
NO FLIGHT WITH CANOPY OPEN BEYOND THIS POINT

AA5-0001 thru 0834
AA5A-0001 thru 0282
AA5B-0001 thru 0399

↑ 113 KNOTS MAX WITH CANOPY OPEN TO HERE
NO FLIGHT WITH CANOPY OPEN BEYOND THIS POINT

AA5A-0283 and Subsequent
AA5B-0400 and Subsequent

Located on lower left side of instrument panel.

CHECK LIST

TAKE-OFF

1. FUEL - FULLEST TANK
2. MIXTURE - FULL RICH
3. AUX. PUMP - ON
4. INSTRUMENTS - SET & CHECK
5. TRIM - SET
6. FLAPS - UP
7. THROTTLE - FULL
8. RAISE NOSE - 55 KNOTS

LANDING

1. FUEL - FULLEST TANK
2. MIXTURE - FULL RICH
3. AUX. PUMP - ON
4. CARB. HEAT - AS REQUIRED
5. FLAPS - AS REQUIRED
6. APPROACH - 70 KNOTS

AA-5A and AA-5B

Interior Placards
Figure 2 (Sheet 3 of 9)

**AA-5 SERIES
MAINTENANCE MANUAL**

Located at static air control

**CLOSE CANOPY WHEN USING ALTERNATE STATIC AIR
SUBTRACT 7 MPH FROM IAS ABOVE 100 MPH IAS
SUBTRACT 80 FEET FROM ALT ABOVE 100 MPH**

AA5A-0001 thru 0282
AA5B-0111 thru 0399

**CLOSE CANOPY WHEN USING ALTERNATE STATIC AIR
SUBTRACT 6 KNOTS FROM IAS ABOVE 87 KNOTS IAS
SUBTRACT 80 FEET FROM ALTITUDE ABOVE 86 KNOTS**

AA5A-0283 and Subsequent
AA5B-0400 and Subsequent

Located at static air control



AA5A-0001 and Subsequent
AA5B-0111 and subsequent

Located beneath instrument panel at cabin walls

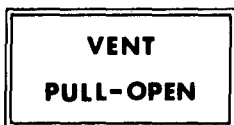

AA-5, AA-5A and AA-5B

Located adjacent to sun visor (if installed)



AA5A-0001 and Subsequent
AA5B-0111 and Subsequent

On control gust lock

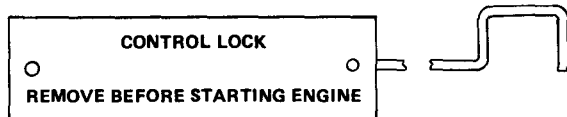

Interior Placards
Figure 2 (Sheet 4 of 9)

Located in glove compartment

TIRE PRESSURE
NOSE 21 LBS.
MAIN 24 LBS.

AA5-0001 thru 0834
AA5A-0001 and Subsequent

TIRE PRESSURE
NOSE 25 LBS.
MAIN 35 LBS.

AA5B-0001 and Subsequent

Located in baggage compartment

120 POUNDS MAXIMUM BAGGAGE
FOR ADDITIONAL LOADING
INSTRUCTIONS SEE WEIGHT AND
BALANCE DATA

AA5-0001 thru 0405

120 POUNDS MAXIMUM BAGGAGE
FOR ADDITIONAL LOADING
INSTRUCTIONS SEE WEIGHT AND
BALANCE DATA
NO HEAVY OBJECTS ON HAT SHELF

AA5-0406 thru 0834
AA5A-0001 and Subsequent
AA5B-0001 and Subsequent

NO STEP
BEFORE FLIGHT
SEAT BACK MUST BE
TURNED DOWN TO COVER
THIS AREA

AA5-0001 thru 0834
AA5A-0001 and Subsequent
AA5B-0001 and Subsequent

NO PASSENGERS
340 POUNDS MAXIMUM CARGO
DISTRIBUTE EVENLY
FOR ADDITIONAL LOADING
INSTRUCTIONS SEE WEIGHT AND
BALANCE DATA
AND OWNERS MANUAL

AA5-0001 thru 0834
AA5A-0001 thru 0282
AA5B-0001 thru 0399

NO PASSENGERS
340 POUNDS MAXIMUM CARGO
DISTRIBUTE EVENLY
FOR ADDITIONAL LOADING
INSTRUCTIONS SEE WEIGHT AND
BALANCE DATA AND PILOTS
OPERATING HAND BOOK

AA5A-0282 and Subsequent
AA5B-0400 and Subsequent

TO OPEN DOORS FROM INSIDE
SLIDE HANDLE FORWARD →

AA5-0406 thru 0834
AA5A-0001 and Subsequent
AA5B-0001 and Subsequent

Interior Placards
Figure 2 (Sheet 5 of 9)

**AA-5 SERIES
MAINTENANCE MANUAL**

Located adjacent to flap control (flap switch)

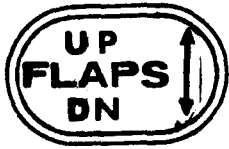

AA5-0001 thru 0834



AA5A-0001 and Subsequent
AA5B-0001 and Subsequent

Located adjacent to flap control

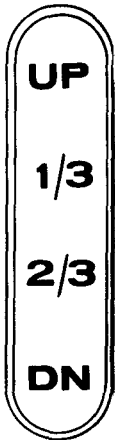

AA5-0001 thru 0834

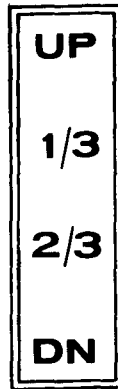

AA5A-0001 and Subsequent
AA5B-0001 and Subsequent

Located adjacent to trim wheel



AA5-0001 thru 0834

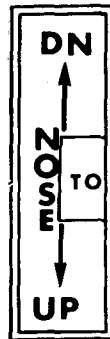

AA5A-0001 and Subsequent
AA5B-0001 and Subsequent

Interior Placards
Figure 2 (Sheet 6 of 9)

**AA-5 SERIES
MAINTENANCE MANUAL**

Located on forward corner railing adjacent to instrument panel

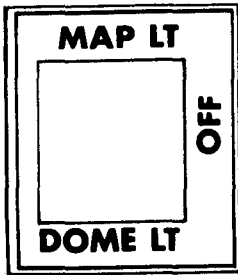

AA5-0001 thru 0834
AA5A-0001 and Subsequent
AA5B-0001 and Subsequent

Located adjacent to canopy latch

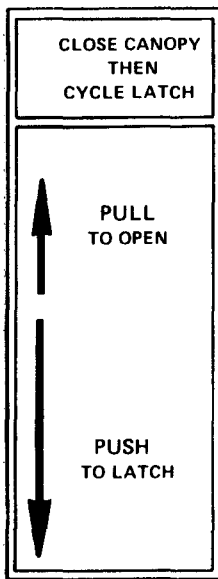

AA5-0001 thru 0834
AA5A-0001 and Subsequent
AA5B-0001 and Subsequent

Located adjacent to canopy latch



AA5-0001 thru 0834
AA5A-0001 and Subsequent
AA5B-0001 and Subsequent

Located on instrument panel shield



Interior Placards
Figure 2 (Sheet 7 of 9)

**AA-5 SERIES
MAINTENANCE MANUAL**

Located on instrument panel

N1448L

AA5-0001 thru 0834
AA5A-0001 thru 0522
AA5B-0001 thru 0692

GRUMMAN AMERICAN
N1448L

AA5A-0523 and Subsequent
AA5B-0693 and Subsequent

Located on instrument panel

FOR FLIGHT WITH REAR SEAT
OCCUPANTS AND/OR BAGGAGE
CARGO, CHECK WEIGHT & BALANCE.

AA5-0001 thru 0834
AA5A-0001 and Subsequent
AA5B-0001 and Subsequent

Located on instrument panel

AVOID CONTINUOUS OPERATION BETWEEN
1850 & 2250 RPM WHILE DESCENDING

AA5B-0001 and Subsequent

Located on instrument panel (depending on system installed)

CAUTION: FLASHING BEACON IN CLOUDS
MAY CAUSE VISUAL DISORIENTATION.

AA-5
AA-5A
AA-5B

TURN OFF STROBE IN CLOUD, FOG
OR HAZE, TAXI WITH STROBE OFF.

Located on fuel selector panel

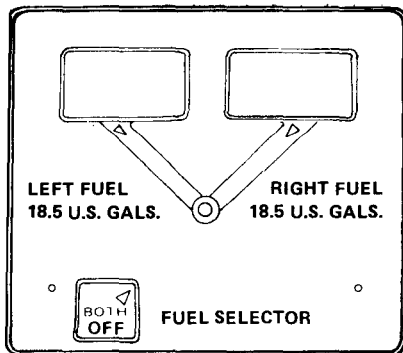

AA5-0001 thru 0834
AA-5A (with standard tanks)

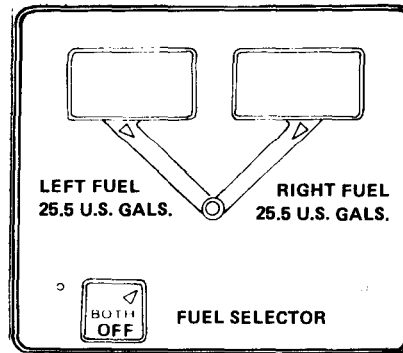

AA-5A (with long-range tanks)
AA5B-0001 and Subsequent

AA-5 SERIES
MAINTENANCE MANUAL

Located on interior of canopy adjacent to lock



AA5A-0456 and Subsequent
AA5B-0594 and Subsequent

Located near center of instrument panel. (If remote switch installed.)

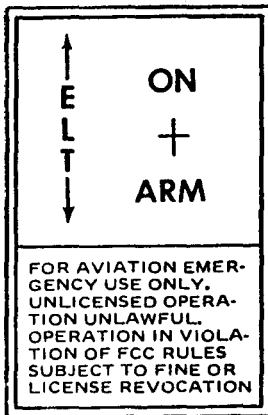

AA5-0525 thru 0834 (if installed)
AA5A-0001 and Subsequent
AA5B-0001 and Subsequent

AA-5 SERIES
MAINTENANCE MANUAL

CHAPTER 12

SERVICING

TABLE OF CONTENTS

| <u>NUMBER</u> | | <u>PAGE</u> |
|---------------|---|-------------|
| 12-0 | SERVICING | |
| | General | 1 |
| | Servicing Points | 1 |
| | Access and Inspection Provisions | 1 |
| | Special Tools and Equipment | 8 |
| 12-1-1 | REPLENISHING | |
| | General | 1 |
| | Refueling | 1 |
| | Defueling | 1 |
| | Engine Oil Replenishing | 3 |
| | Brake Fluid Replenishing | 6 |
| | Tire Inflation | 6 |
| | Battery Fluid Replenishing | 6 |
| 12-2-1 | SCHEDULED SERVICING | |
| | General | 1 |
| | Engine Oil Servicing | 1 |
| | Engine Air Filter Servicing (AA5-0001 through AA5-0640) | 2 |
| | Engine Air Filter Servicing (AA5-0641 and AA-5A Aircraft) | 2 |
| | Engine Air Filter Servicing (AA-5B Aircraft) | 3 |
| | Vacuum System Air Filter Servicing | 3 |
| | Airframe Lubrication | 7 |
| | Auxiliary Fuel Pump Filter Servicing | 10 |
| | Carburetor Filter Servicing | 10 |
| 12-3-1 | UNSCHEDULED SERVICING | |
| | General | 1 |
| | Ice and Snow Removal | 1 |

**AA-5 SERIES
MAINTENANCE MANUAL**

| <u>NUMBER</u> | | <u>PAGE</u> |
|---------------|--------------------------------|-------------|
| | Battery Servicing and Charging | 1 |
| | External Cleaning | 2 |
| | Internal Cleaning | 2 |
| | Windshield and Window Cleaning | 2 |
| | Engine Cleaning | 3 |
| | Propeller Care | 3 |

SERVICING

1. General

This section describes the procedures and precautions necessary for proper servicing of the AA-5 series aircraft. Safety precautions are also presented to acquaint the user with those potential hazards that may not be readily apparent to persons unfamiliar with the AA-5 series aircraft.

2. Servicing Points

Figure 1 illustrates the locations of the major servicing points on the AA-5 aircraft. Figure 2 lists approved lubricants.

3. Access and Inspection Provisions

Various openings in the airframe are provided to enable access for inspection or maintenance. In addition to the normal access provided by opening the engine cowl the other openings, which are covered by removable plates, are located as shown in Figure 3.

Access to the interior of the aft fuselage is gained by removal of the panel at the rear of the baggage compartment. Control cables are exposed by removal of the aft console, and by removal of the inspection plate beneath the rear passenger seat.

**AA-5 SERIES
MAINTENANCE MANUAL**

1. MAIN WHEEL BEARINGS (LEFT AND RIGHT) — Grease with MIL-G-25760 (See Figure 2) grease every 100 hours or as required.

TIRES — Inflate to 24 psi on the AA-5 and AA-5A and 35 psi on the AA-5B.
2. BATTERY TERMINALS — Coat with VV-P-236 (Figure 2) petrolatum as required to prevent corrosion.

BATTERY — Fill with distilled water as required to maintain fluid level at top of plates.
3. ENGINE OIL — (Figure 2) Change engine oil every 50 hours. Add oil as required to maintain safe level.
4. NOSE WHEEL BEARINGS — Grease with MIL-G-25760 (Figure 2) grease every 100 hours or as required.

NOSE WHEEL TIRE — Inflate to 21 psi on the AA-5 and AA-5A and 25 psi on the AA-5B.
5. NOSE FORK SWIVEL AND BELLVILLE WASHERS — Grease with MIL-G-7711 (See Figure 2) grease every 100 hours or as required.
6. T-COLUMN NEEDLE BEARING — Grease with MIL-G-7711 (Figure 2) grease as required.
7. T-COLUMN, RUDDER AND FLAP TORQUE TUBE OILITE BEARINGS AND ROLLER CHAIN — Oil with MIL-L-7870 (Figure 2) as required.
8. TRIM WHEEL GEARS — Grease with MIL-G-7711 (Figure 2) as required.
9. SEAT TRACKS — Oil with MIL-L-7870 (Figure 2) oil every 100 hours.

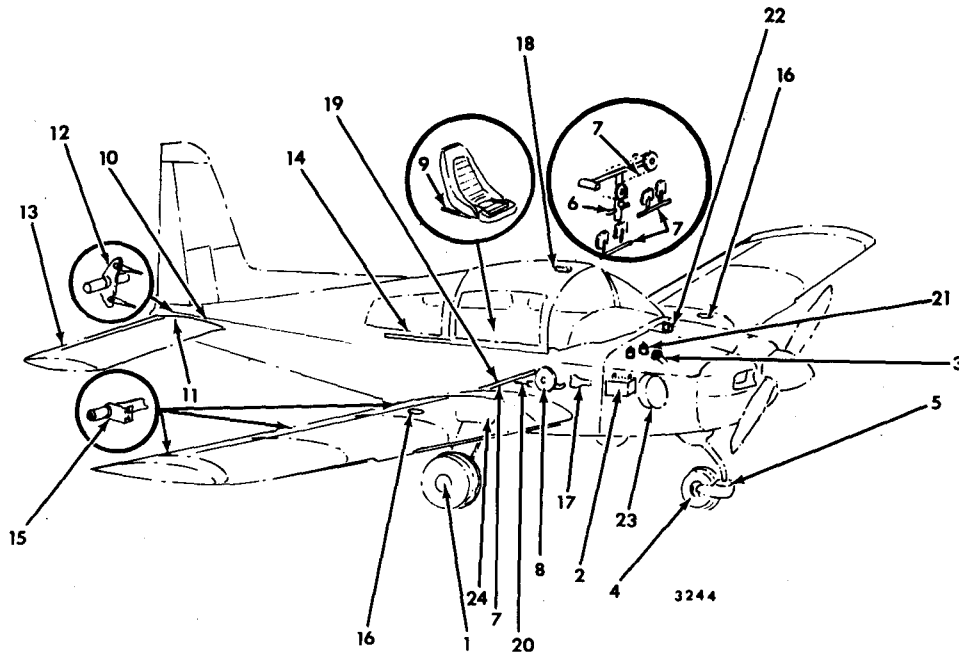

Servicing Points (Sheet 1 of 2)
Figure 1

**AA-5 SERIES
MAINTENANCE MANUAL**

10. TRIM ACTUATOR SHAFT — Grease with MIL-G-7711 (Figure 2) grease as required.
11. TRIM TAB BELLCRANKS — Oil with MIL-L-7870 (Figure 2) oil as required.
12. RUDDER AND ELEVATOR BELLCRANK CLEVIS PINS — Oil with MIL-L-7870 (Figure 2) oil as required.
13. TRIM TAB HINGE — Oil with MIL-L-7870 (Figure 2) oil (Note C).
14. CANOPY SLIDES — Spray with E-Z-Free lubricant as required.
15. ALL CONTROL SURFACE BEARINGS — Grease with Aeroshell No. 6 or MIL-G-7711 (Figure 2) as required. (Note A)
16. FUEL SELECTOR VALVE AND FUEL CAP GASKET — Grease with MIL-G-6032A grease as required.
FUEL TANKS (AA-5 and AA-5A) — Fill with 80/87 minimum grade aviation fuel (pink). (Note B.)
FUEL TANKS (AA-5B) — Fill with 100/130 minimum grade aviation fuel (green). (Note B.)
17. FRESH AIR VENTS — Oil with MIL-L-7870 (Figure 2) as required.
18. CANOPY LATCH — Grease with white grease, Lubriplate No. 501 or equivalent as required.
19. FLAP DRIVE JACKSCREW — Oil with MIL-L-7870 (Figure 2) oil. Coat with a light film for corrosion prevention only.
20. FLAP POSITION INDICATOR CABLE — Grease with MIL-G-21164 (Figure 2) Molybdenum Disulphide grease as required.
21. BRAKE RESERVOIRS — Fill to within 1/4 inch of top with MIL-H-5606 (Figure 2) hydraulic fluid, as required.
22. VACUUM SYSTEM FILTER — Replace filter at 400 hours or as required.
23. ENGINE AIR FILTER — Replace and service as required. (See Section 12-2-1, this chapter.)
24. FUEL SUMP DRAINS — Clear of water and sediment prior to first flight of day.

NOTES:

- A. Elevator bearings do not require lubrication.
- B. 100 Low Lead Aviation Fuel (blue) is also approved on the AA-5A and AA-5B. Refer to the latest revision of Lycoming Service Instruction No. 1070 for further information concerning fuels.
- C. Acceptable substitute is powdered graphite (MIL-G-6711) (Figure 2).

**AA-5 SERIES
MAINTENANCE MANUAL**

| TRADE NAME | MANUFACTURER |
|--|---|
| MIL-G-21164 GREASE (Note 1) | |
| Aeroshell Grease 17 Braycote 664 PED 3350 Grease Royco 64 Grease TG-4727 Grease | Shell Oil Company Bray Oil Company Standard Oil Company Royal Lubricants Company Texaco Inc. |
| MIL-G-6711 GRAPHITE (Note 1) | |
| Graphite Graphite Graphite | Dixon Company Electrofilm Company Electro-Graph Company |
| MIL-H-5606 HYDRAULIC FLUID (Note 1) | |
| 3125 HVD Oil Brayco Micronic 756C PED-3337, -3335 Royco 756 A & B XSL 7828 YT-283 | Humble Oil & Refining Company Bray Oil Company Standard Oil Company Royal Lubricants Company Shell Oil Company Union Carbide |
| MIL-L-22851 OIL (Note 1) | |
| Premium AD 80 Premium AD 120 | Texaco Inc. Texaco Inc. |
| VV-P-236 PETROLATUM (Note 1) | |
| Braycote 236 Parmo 70 Royco 1 R | Bray Oil Company Humble Oil & Refining Company Royal Lubricants Company |
| MIL-L-7870 OIL (Note 1) | |
| Brayco 363 Cosmolube 263 Enco Instrument Oil Low Temperature Oil 1692 Royco 363 | Bray Oil Company E. F. Houghton Company Humble Oil & Refining Company Texaco Inc. Royal Lubricants Company |
| MIL-G-25760 GREASE (Note 1) | |
| Aeroshell Grease 16 Braycote 6605 Royco 60R Supermil ASU No. 06752 TG-4971 Grease | Shell Oil Company Bray Oil Company Royal Lubricants Company American Oil Company Texaco Inc. |
| MIL-G-7711 GREASE (Note 1) | |
| Aeroshell No. 6 Regal AFB 2 | Shell Oil Company Texaco Inc. |

Lubricants
Figure 2 (Sheet 1 of 2)

**AA-5 SERIES
MAINTENANCE MANUAL**

| TRADE NAME | MANUFACTURER |
|---|---|
| MIL-L-6082B ENGINE OIL (Notes 1 and 2) | |
| Aeroshell W 120* Aeroshell W80* Aeroshell Oil 65** Aeroshell Oil 100** Chevron Aero Oil Grade 120* Chevron Aviation Oil 65** Grade 1100** RT-451* RM-173E* RM-180E* Avrex 100/1065** Avrex 101/1100** TX-6309* Premium AD 120* Premium AD 80* Conoco Aero Oil 1065** Conoco Aero Oil 1100** Chevron Aero Oil Grade 120* Oil E-120* Oil A-100* Oil E-80* Grade 1065** Grade 1100** | Shell Oil Company Shell Oil Company Shell Oil Company Shell Oil Company Standard Oil Company Chevron Oil Company Chevron Oil Company Mobil Oil Company Mobil Oil Company Mobil Oil Company Mobil Oil Company Mobil Oil Company Texaco Inc. Texaco Inc. Texaco Inc. Continental Oil Company Continental Oil Company Standard Oil Company Exxon Company Exxon Company Exxon Company Champlin Oil & Refining Company Champlin Oil & Refining Company |

*Ashless Dispersant Oils with additives conforming to MIL-L-22851.

**Straight Mineral Oils.

Note 1: The vendor products listed in this chart have been selected as representative of the specification under which they appear. Other equivalent products conforming to the same specifications may be used.

Note 2: Oils conforming to the latest revision of Lycoming Service Instruction No. 1014 may be used.

AA-5 SERIES
MAINTENANCE MANUAL

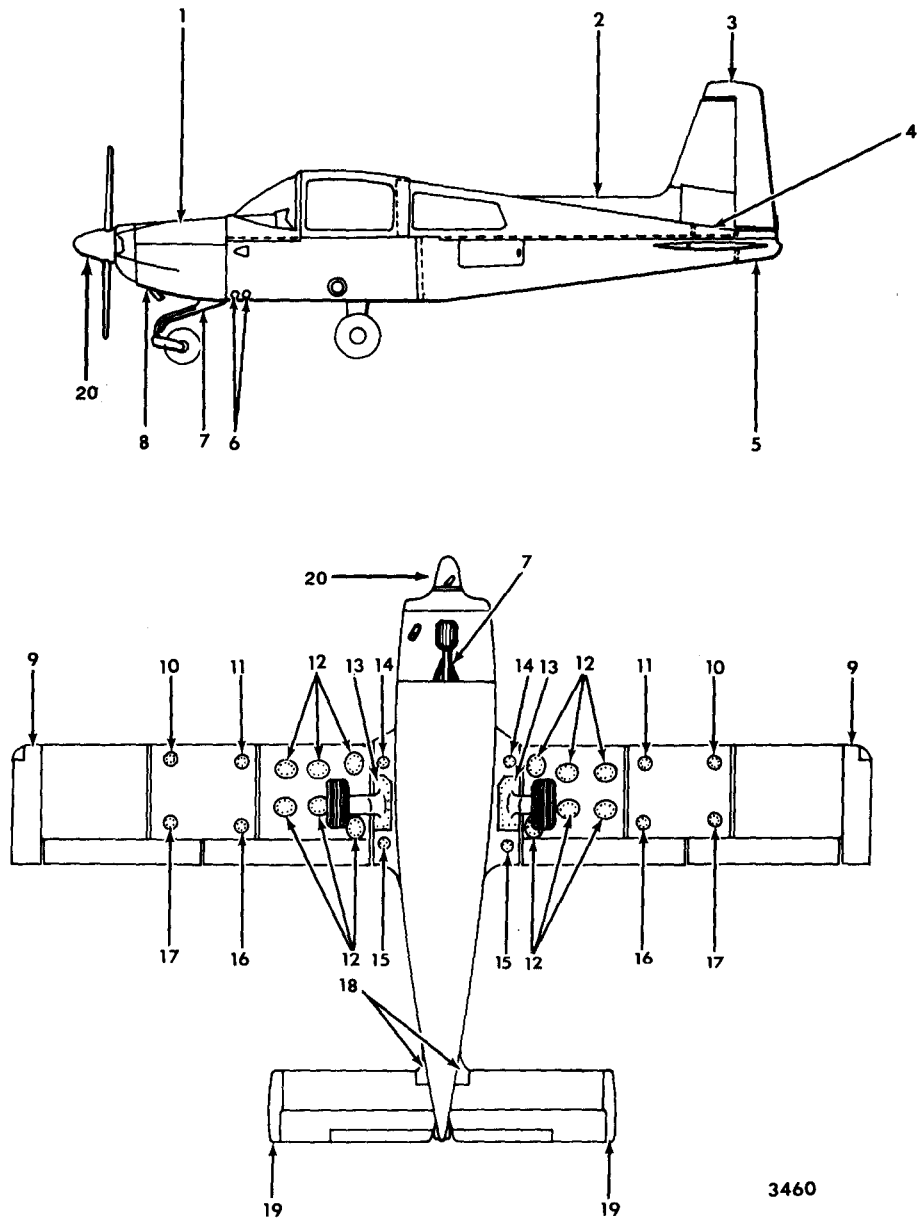

3460

Access Openings (Sheet 1 of 2)
Figure 3

**AA-5 SERIES
MAINTENANCE MANUAL**

1. Engine Upper Cowl
2. Dorsal Fin
3. Rudder Tip
4. ELT Access Panel
5. Tailcone
6. Nose Gear Torque Tube Bolt Access Plates
7. Nose Gear Boot
8. Engine Lower Cowl
9. Wing Tip
10. Wing Outboard Forward Access Plate
11. Wing Inboard Forward Access Plate
12. Fuel Tank Access Plates
13. Landing Gear Root Fairing
14. Wing Root Forward Access Plate
15. Wing Root Aft Access Plate
16. Wing Inboard Aft Access Plate
17. Wing Outboard Aft Access Plate
18. Horizontal Stabilizer Root Fairing
19. Elevator Tips
20. Propeller Spinner

Access Openings (Sheet 2 of 2)
Figure 3

**AA-5 SERIES
MAINTENANCE MANUAL**

4. SPECIAL TOOLS AND EQUIPMENT

The following is a list of service tools available from the Parts Department. See the applicable parts catalog for ordering information.

| TOOL NUMBER | TOOL NAME | MODELS APPLICABLE | FIGURE SHOWN |
|----------------------------------|---|-------------------|--------------|
| DE-0001-501 | Main Gear Jack Fitting | AA-5 | 4 |
| DE-0002-501 (Old P/N A-11533) | Rudder Rigging Fixture | AA-5, 5A, 5B | 5 |
| DE-5003-501 | Aileron & Flap Rigging Fixture | AA-5, 5A, 5B | 6 |
| DE-5004-501 | Trim Tab Rigging Fixture | AA-5 | 7 |
| DE-5004-502 | Trim Tab Rigging Fixture | AA-5A, 5B | 8 |
| DE-5005-501 | Control Wheel/Elevator Rigging Fixture | AA-5, 5A, 5B | 9 |
| DE-5006-1 | Aileron & Flap Bearing Sizing Tool: 1-1/8 inch I.D. & 1-1/2 inch I.D. | AA-5, 5A, 5B | Not Shown |
| ST 1064 | Canopy Track Sizing Tool | AA-5, 5A, 5B | 10 |
| ST 1074 | Canopy Track Drilling Tool | AA-5, 5A, 5B | 10 |
| 719-40 MRP | Spring Scale-Chatillon Gauge R (0-40 lb. Range) | AA-5, 5A, 5B | 11 |

AA-5 SERIES
MAINTENANCE MANUAL

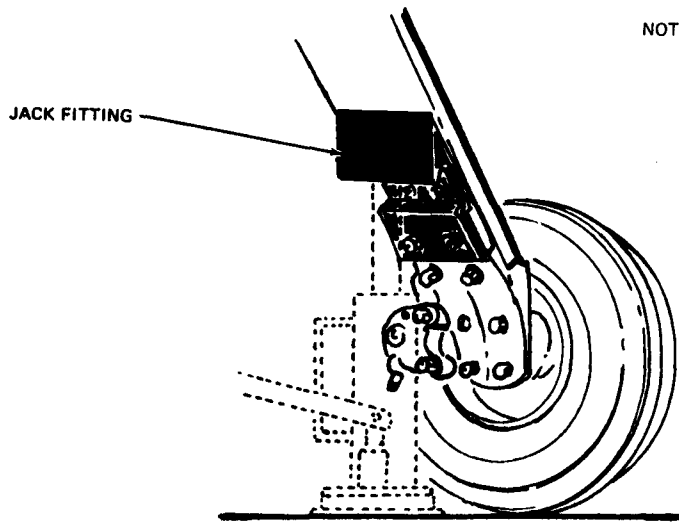

NOTE: THE JACK FITTING IS NOT PERMANENTLY INSTALLED. IT IS A "SLIP ON" FITTING THAT CAN BE USED ONLY ON AA-5 AIRCRAFT MANUFACTURED PRIOR TO 1975.

3364

Main Gear Jack Fitting
Figure 4

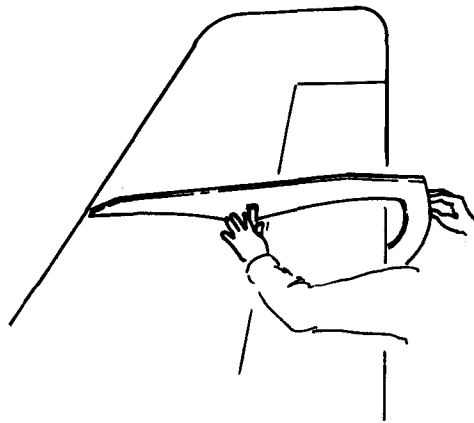

3025

Rudder Rigging Fixture
Figure 5

AA-5 SERIES
MAINTENANCE MANUAL

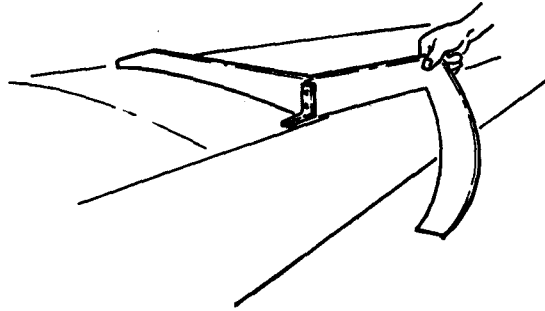

Aileron & Flap Rigging Fixture
Figure 6

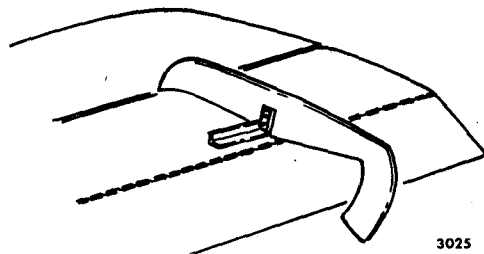

Trim Tab Rigging Fixture AA-5
Figure 7

AA-5 SERIES
MAINTENANCE MANUAL

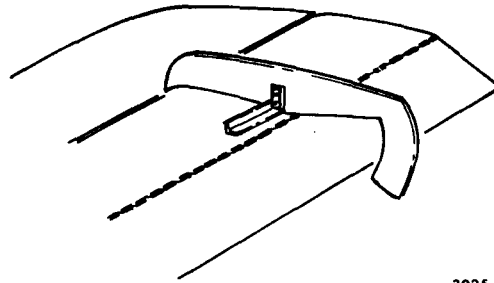

3025

Trim Tab Rigging Fixture (AA-5A, AA-5B)
Figure 8

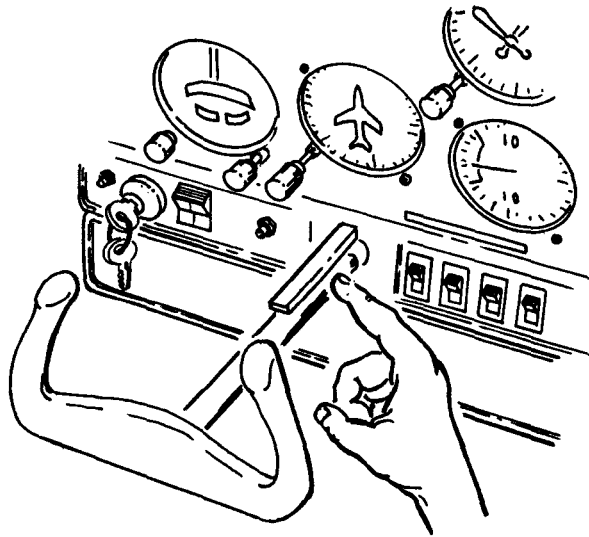

3026

Control Wheel/Elevator Rigging System
Figure 9

AA-5 SERIES
MAINTENANCE MANUAL

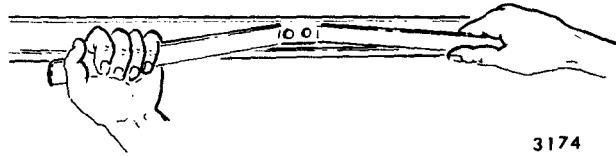

Canopy Track Sizing Tool
Figure 10

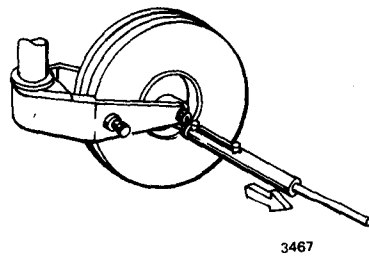

Spring Scale - Chatillon Gauge R
Figure 11

REPLENISHING

1. General

The replenishing procedures contained in this section provide the proper methods for replacing consumed fuel, oil, hydraulic fluid, and battery electrolyte. Also included are methods for inflation of tires.

2. Refueling

Refueling is accomplished by pumping or pouring fuel into the two wing tanks through their respective filler caps. (See Figure 1.) When fueling the aircraft, the following safety precautions should be followed:

- A. Never refuel the aircraft with the engine running.
- B. Always ensure that the aircraft is grounded before refueling.
- C. Ensure that no one is smoking within 100 feet of the aircraft during refueling.
- D. Ensure that all aircraft electrical systems are deenergized while refueling.
- E. Ensure that no aircraft radar or other powerful transmitters are operating within 100 feet of the aircraft during fueling.
- F. If fuel is spilled, ensure that the area of spillage is thoroughly flushed with water and that all residual fuel and vapor have dissipated or been neutralized prior to starting the aircraft engine.
- G. Ensure that all fuel used is from an approved source and that it is free of contamination.

The AA-5 aircraft must be fueled with the following fuel:

CAUTION: UNDER NO CIRCUMSTANCES SHOULD FUEL OF A LOWER OCTANE RATING THAN THAT SPECIFIED BELOW OR AUTOMOTIVE FUEL (REGARDLESS OF OCTANE) BE USED.

Grade (and color): AA-5 and AA-5A aircraft — 80/87 Minimum Grade Aviation Fuel (Pink). 100 Low Lead Aviation Fuel (Blue) is also approved. AA-5B aircraft — 100/130 Minimum Grade Aviation Fuel (Green). 100 Low Lead Aviation Fuel (Blue) is also approved. Refer to the latest revision of Lycoming Service Instruction No. 1070 and other Lycoming Publications for further information concerning fuels.

NOTE: The following quantities were measured at an ambient temperature of 70°F. Changes from this temperature will cause a corresponding change in fuel quantities.



The AA-5 and the AA-5A (with standard tanks) fuel system capacities are as follows:

| | <u>U.S. Gallons</u> | <u>Liters</u> | <u>Imp. Gallons</u> |
|----------------------|-------------------------|---------------|---------------------|
| Total Fuel Capacity: | 38.0 | 143.8 | 31.6 |
| Each Tank: | 19.0 | 71.9 | 15.8 |
| Total Usable Fuel: | 37.0 | 140.0 | 30.8 |

AA-5 SERIES
MAINTENANCE MANUAL

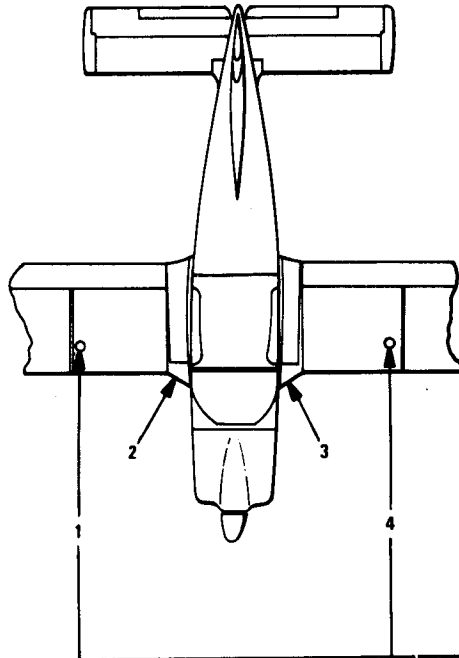
1. Right Fuel Tank Cap
2. Right Sump (Under Wing)
3. Left Sump (Under Wing)
4. Left Fuel Tank Cap



| | |
|---|---|
| FUEL MIN 80/87 OCT 19 U.S. GAL. CAP | FUEL MIN 100/130 OCT. 26.3 U.S. GAL. TOTAL CAP. 19.0 U.S. GAL. TO TAB |
|  |  |
| AA - 5 & AA - 5A (STD. TANKS) | AA - 5B ONLY |

3466

| |
|---|
| FUEL MIN 80/87 OCT. 26.3 U.S. GAL. TOTAL CAP. 19.0 U.S. GAL. TO TAB |
|---|

AA - 5A (OPTIONAL
LONG RANGE TANKS)

Fueling Points
Figure 14

**AA-5 SERIES
MAINTENANCE MANUAL**

The AA-5A (with optional long range tanks) and the AA-5B fuel system capacities are as follows:

| | <u>U.S. Gallons</u> | <u>Liters</u> | <u>Imp. Gallons</u> |
|----------------------|-------------------------|---------------|---------------------|
| Total Fuel Capacity: | 52.6 | 199.1 | 43.8 |
| Each Tank: | 26.3 | 99.5 | 21.9 |
| Total Usable Fuel: | 51.0 | 193.0 | 42.5 |

After refueling, ensure that both fuel tank caps are securely installed prior to flight.

3. Defueling

WARNING: WHEN SIPHONING FUEL FROM THE TANKS NEVER ATTEMPT TO START SIPHONING BY MOUTH. INTRODUCTION OF EVEN A SMALL AMOUNT OF FUEL INTO THE LUNGS CAN BE FATAL. USE ONLY SAFETY APPROVED SIPHONING EQUIPMENT.

Defueling is best accomplished by siphoning fuel through a siphon hose introduced into the tank through the fuel filler cap. If the tank is to be completely emptied, the small amount of fuel that cannot be removed by siphoning can be removed through the sump drain beneath the wing. During the aircraft defueling, observe the safety precautions specified in Paragraph 2.

4. Engine Oil Replenishing

Engine oil replenishment is accomplished by pouring oil into the oil filler spout. (See Figure 2.) Oil quantity can be conveniently checked by use of the dipstick attached to the oil filler spout cap.

Oil quantity is checked as follows:

- A. Open right side of engine cowl (or oil access door).
- B. Locate oil filler spout. (See Figure 2.)
- C. Unscrew oil filler spout cap.
- D. Remove dipstick from engine and wipe oil from dipstick with a clean cloth or paper towel.
- E. Replace dipstick into filler spout and tighten finger tight.
- F. Unscrew and remove dipstick. Check oil level on dipstick versus the markings stamped on the dipstick.
- G. Wipe oil from dipstick with a clean cloth or paper towel and replace dipstick in filler spout. Tighten filler spout cap finger tight.

NOTE: When tightening the cap, ensure that it is secure. Do not overtighten as this may damage the O-ring seal in the cap.

Replenish engine oil using oil of the following specification:

MIL-L-6082B (Section 12-0, Figure 2) Aviation Grade Straight Mineral oil shall be used to replenish oil supply during the first 25 hours of operation and at the first 25-hour oil change. Continue to use this grade of oil the first 50 hours of operation.

**AA-5 SERIES
MAINTENANCE MANUAL**

NOTE: The aircraft is delivered from the factory with corrosion preventive aircraft engine oil. This oil should be drained after the first 25 hours of engine operation.

MIL-L-22851 (Section 12-0, Figure 2) Ashless Dispersant Oil: This specification oil shall be used after the first 50 hours of engine operation.

***Recommended Viscosity**

| <u>Average Ambient Air Temperature</u> | <u>Mineral Grade</u> | <u>Ashless Dispersant</u> |
|--|--------------------------|-------------------------------|
| Above 16°C (60°F) | SAE 50 | SAE 40 or SAE 50 |
| -1°C (30°F) to 32°C (90°F) | SAE 40 | SAE 40 |
| -18°C (0°F) to 21°C (70°F) | SAE 30 | SAE 40 or SAE 30 |
| Below -12°C (10°F) | SAE 20 | SAE 30 |

*Refer to latest revision of Lycoming Service Instruction No. 1014 and other Lycoming Publications for further information.

Replenish engine oil as follows:

- A. Open right side of engine cowling.
- B. Locate oil filler spout (Figure 2) and unscrew cap.
- C. Using a clean rag or paper towel wipe any oil or foreign material from the edges of the oil filler spout opening. Also wipe oil from the dipstick.

NOTE: When adding engine oil, ensure that no dirt or foreign material is allowed to enter the oil filler spout, and that the cap/dipstick is clean prior to reinstallation.

- D. Pour oil of proper specification and viscosity into filler spout to achieve desired oil level.

NOTE: When adding engine oil during extremely cold weather, the change in viscosity due to extreme cold may cause the oil to pour very slowly. Keeping the oil in a heated building or warming it prior to use may expedite oil replenishment.

- E. Replace oil filler spout cap/dipstick and tighten finger tight.

NOTE: Any oil spillage, particularly on exhaust manifolds, should be wiped clean prior to flight.

- F. Close and secure engine cowl.

NOTE: Check that cowl latches are flush with cowl.

The AA-5, AA-5A, and AA-5B aircraft oil system capacities are as follows:

NOTE: The following quantities were measured at an ambient temperature of 70°F.

| | <u>U.S. Quarts</u> | <u>Liters</u> | <u>Imp. Quarts</u> |
|-----------------------|--------------------|---------------|--------------------|
| Total Engine Capacity | 8.00 | 7.59 | 6.66 |
| Minimum Safe Quantity | 2.00 | 1.89 | 1.66 |

AA-5 SERIES
MAINTENANCE MANUAL

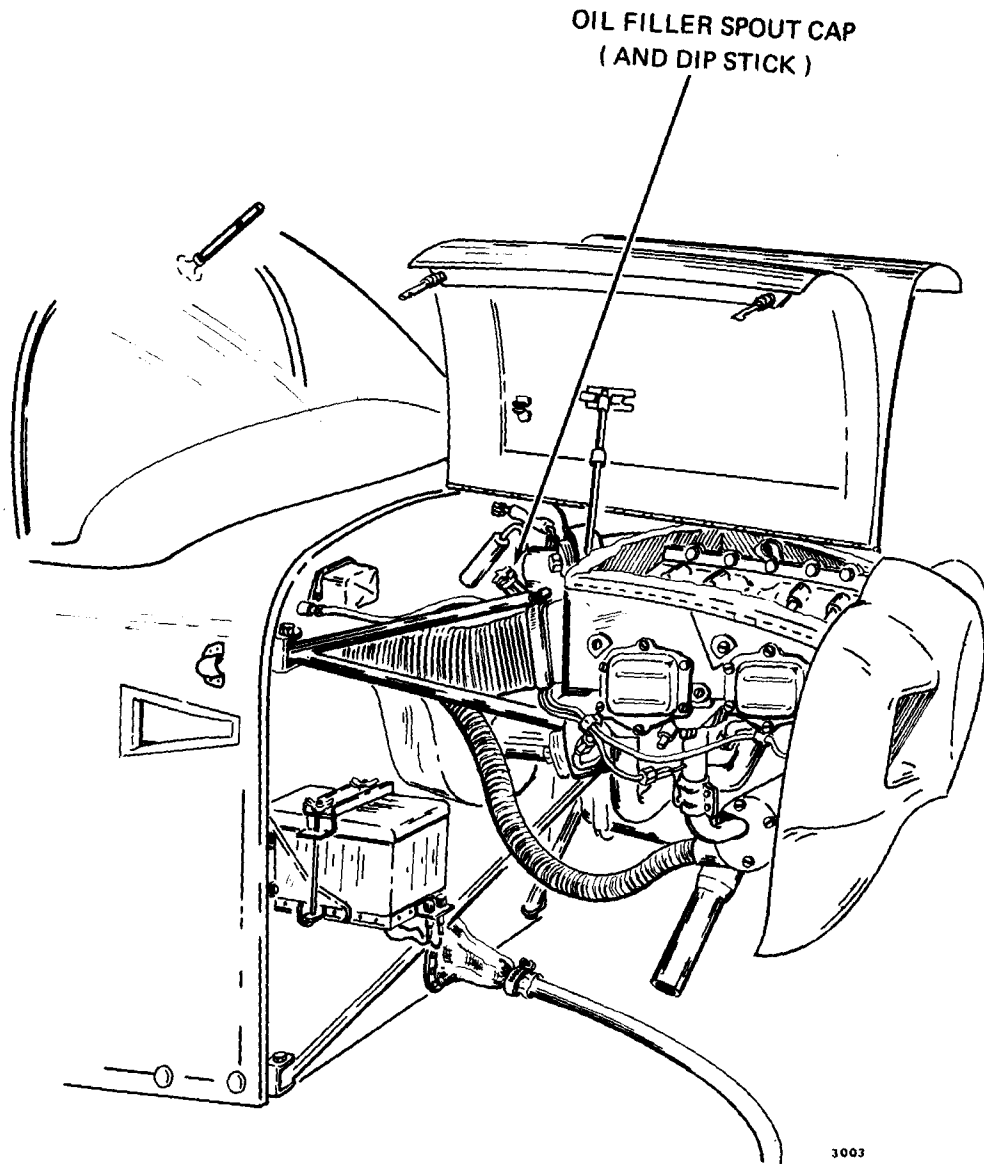

Oil Filler Spout
Figure 15

**AA-5 SERIES
MAINTENANCE MANUAL**

5. Brake Fluid Replenishing

Brake fluid replenishing is accomplished as follows:

NOTE: When replenishing brake fluid, ensure that the fluid used conforms to specification MIL-H-5606, (Section 12-0, Figure 2) and that the fluid is uncontaminated.

- A. Locate brake cylinder reservoirs as shown in Figure 3.
- B. Using a clean rag or paper towel, wipe any accumulated dirt or other foreign material from area around filler plugs.
- C. Remove filler plugs.
- D. Using a syringe, hand pump, or other suitable means, add brake fluid (MIL-H-5606) (Section 12-0, Figure 2), to the reservoirs through the filler ports until the level of fluid is 1/4 inch from the top of the reservoir.
- E. Replace filler plugs in reservoirs.
- F. Check brake action.
- G. If more fluid is required, repeat Steps (B) through (F).
- H. If it is necessary to bleed the brakes, refer to Chapter 32.

6. Tire Inflation

WARNING: WHEN INFLATING TIRES, USE REGULATED AIR PRESSURE THROUGH VALVE STEMS. TIRE PRESSURES ARE AS FOLLOWS:

MAIN LANDING GEAR TIRES — 35 psig (AA-5B) 24 psig (AA-5 & AA-5A)
NOSE LANDING GEAR TIRES — 25 psig (AA-5B) 21 psig (AA-5 & AA-5A)

7. Battery Fluid Replenishing

WARNING: THE BATTERY CONTAINS A SULPHURIC ACID ELECTROLYTE SOLUTION. DO NOT ALLOW THE ELECTROLYTE TO COME INTO CONTACT WITH CLOTHES OR SKIN. ANY SPILLAGE SHOULD BE FLUSHED WITH WATER OR NEUTRALIZED WITH BAKING SODA IMMEDIATELY.

Replenish battery fluid as follows:

- A. Open the engine cowl on the right hand side.
- B. Remove the two wing nuts (1), washers (2), tiedown (3), heat shield (4), and battery cover (5) as shown in Figure 4.
- C. Using a clean rag or paper towel, wipe all dirt and foreign material from the area around the battery filler plugs.
- D. Remove filler plugs (6) and visually check electrolyte level in battery. If electrolyte level is below the bottom of the split rings, distilled water should be added.

NOTE: When replenishing battery water, use only distilled water. Ensure that the electrolyte level in the battery comes to bottom of split rings. Do not overfill.

AA-5 SERIES
MAINTENANCE MANUAL

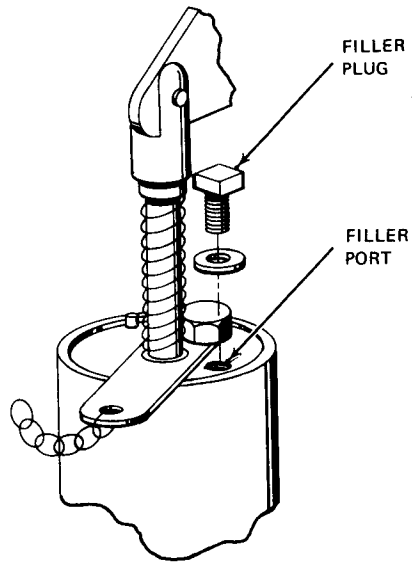

AA5 AND AA5A

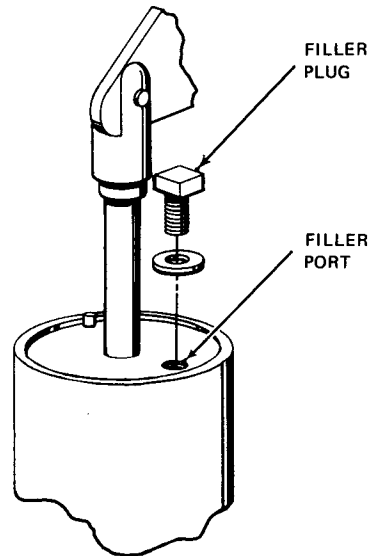

AA5B 0945 AND SUBSEQUENT

Brake Cylinder
Figure 3

AA-5 SERIES
MAINTENANCE MANUAL

- E. Add water to bring electrolyte level to top of plates.
- F. Install battery filler plugs (6).
- G. Install battery box cover (5), heat shield (4), and tiedown (3). Secure with the washers (2) and wing nuts (1).
- H. Close and secure cowl.

NOTE: Check that cowl latches are flush with cowl.

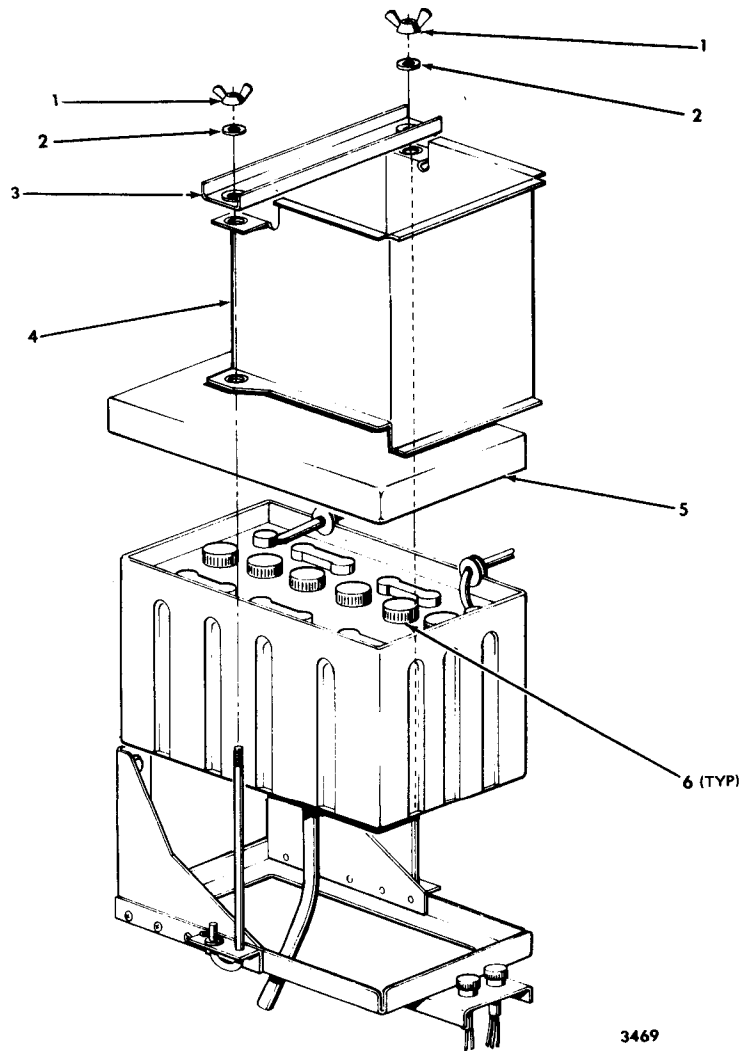

- 1. Wing Nut
- 2. Washer
- 3. Tiedown
- 4. Heat Shield
- 5. Battery Cover
- 6. Filler Plug

Battery Servicing
Figure 4

SCHEDULED SERVICING

1. General

This section provides the procedures required to perform servicing that is required on a scheduled basis.

2. Engine Oil Servicing

The engine oil should be changed after the first 25 hours of operation. It should be refilled with straight mineral oil conforming to Specification No. MIL-L-6082B (Section 12-0, Figure 2). This straight mineral oil should be used until a total of 50 hours has accumulated, then it should be drained and replaced with dispersant oil. The oil should be changed at least every 50 hours or 6 months, whichever occurs first. At the time of each oil change, the engine oil strainers should be removed, cleaned, and inspected for metal particles. If the engine is equipped with a paper throw-away type oil filter, it should be cut apart and inspected for accumulations of metal chips and evidence of internal engine failure.

Change engine oil as follows:

- A. Open both sides of upper engine cowl, and secure with support tubes.
- B. Remove lower engine cowl.
- C. Locate engine oil drain plug (Figure 5) and cut safety wire securing plug.

NOTE: On aircraft equipped with a quick oil drain, do not cut safety wire at plug. Place a hose over the quick drain and push the fitting up into its detent to drain the oil.
- D. Place a suitable container under the oil drain.
- E. Unscrew the drain plug and allow the oil to drain thoroughly.
- F. Remove remaining safety wire from drain plug and safety wire hole on engine.
- G. Using a clean rag or paper towel, wipe drain plug clean and clean area on engine around oil drain.
- H. Reinstall drain plug and safety wire.
- I. Remove, clean, and inspect engine oil strainers in accordance with Lycoming Operating Manual.
- J. Replace strainers per Lycoming Operating Manual.
- K. Unscrew and remove engine oil filler spout plug.
- L. Pour 8 quarts of oil conforming to Specification No. MIL-L-6082B (Section 12-0, Figure 2) or ashless dispersant aviation grade into oil filler spout.
- M. Using a clean rag or paper towel wipe oil from dipstick, and reinstall engine oil filler spout plug. Tighten finger tight.
- N. Reinstall lower engine cowl.
- O. Close and secure upper engine cowl (both sides).

AA-5 SERIES
MAINTENANCE MANUAL

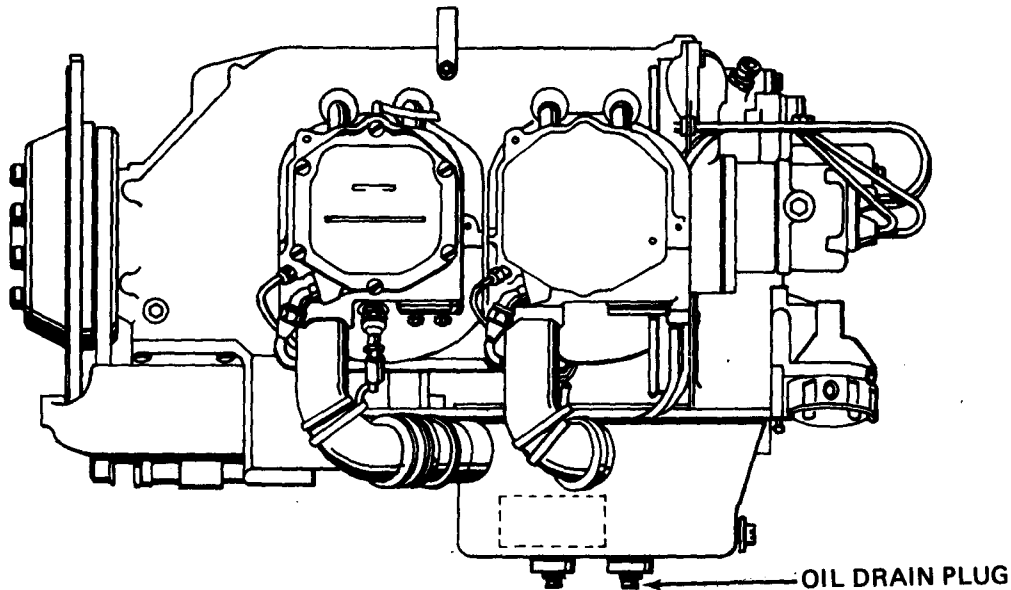

Engine Oil Drain Plug
Figure 5

NOTE: Check that the cowl latches are flush with cowl.

3. Engine Air Filter Servicing (AA5-0001 through AA5-0640)

- A. Remove the screws attaching the adapter assembly, air filter and air box assembly together. (See Figure 2 of Section 30-1-1.)

WARNING: USE SOLVENTS IN A WELL VENTILATED AREA. AVOID BREATHING FUMES. KEEP AWAY FROM FLAMES.

- B. Thoroughly wash the filter in petroleum solvent. Make certain all dirt is removed and filter is in serviceable condition. If filter has flocking worn from screen wire, replace filter.
- C. Dry the filter at room temperature. Filter must be completely dry before proceeding with next step. If the filter is not dry, the solvent will prevent oil from adhering to the filter, thereby reducing the filter efficiency.
- D. Immerse the filter in the grade oil called for on the filter. If none is called out, use engine preservative oil per MIL-L-21260. (Section 12-0, Figure 2.)
- E. After removing the filter from the oil, allow it to drain thoroughly before installing in the aircraft.
- F. Inspect the gasket between the air filter and air box. If damaged or otherwise defective, replace with a new gasket.
- G. Position the air box assembly, filter, and adapter together and install the screws.
- H. Position the air box assembly to the carburetor and forward cowl, and install the bolts being sure to install the left rear bolt with a washer to prevent it from bottoming out in the carburetor.
- I. Connect the carburetor heat control to the air box assembly.
- J. Install the carburetor heat inlet hose and clamp to the air box assembly.
- K. Install the lower cowl.

4. Engine Air Filter Servicing (AA5-0641 and subsequent and AA-5A Aircraft)

The engine air filter element should be replaced every 100 hours of engine operation, every 12

calendar months, or when torn (or 50% covered with foreign material). Filter element, Part No. 13203 or 8994914, should be used as replacement.

Replace the engine air filter element as follows:

NOTE: Never blow off filter with compressed air or attempt to wash element in any liquid or soak in oil.

- A. Locate filter access per Figure 6. Remove the screws that attach the filter cover plate and remove the plate.
- B. Remove old filter element and install replacement.
- C. Replace filter cover plate and reinstall screws attaching it.

5. Engine Air Filter Servicing (AA-5B Aircraft)

- A. On Aircraft AA5B-0001 through 0549 using filter Part No. 8994656, and Aircraft AA5B-0550 through 0950 using filter Part No. 5500015-501, replace the foam type filter element every 300 hours, every twelve months, when torn or 50 percent covered with foreign material. Replace filter as follows:

NOTE: Never blow off filter with compressed air or attempt to wash element in any liquid or soak in oil.

- (1) Open both sides of upper cowl and secure with support tubes.
 - (2) Remove lower engine cowl.
 - (3) Unbolt filter access door (Figure 7) on bottom of air box/filter assembly.
 - (4) Remove old filter and install replacement.
 - (5) Close and secure filter access door.
 - (6) Install lower engine cowl.
 - (7) Close and secure upper engine cowl.
- B. On Aircraft AA5B-0951 and subsequent, check the paper type carburetor air filter during each preflight inspection. If the filter is dusty it may be removed and cleaned with compressed air or washed in a solution of water and Donaldson D-1400 filter cleaning compound or equivalent. Replace the filter after one year, after ten cleanings, or after 500 flight hours, whichever occurs first. Service filter as follows:
 - (1) Open both sides of upper cowl and secure with tubes.
 - (2) Remove lower engine cowl.
 - (3) Unbolt filter access door (See Figure 7.) on bottom of air box/filter housing.
 - (4) Remove filter. Clean and inspect as follows:
 - (a) Clean filter, using one of methods described above.
 - (b) After filter is clean and dry inspect filter by using a bright light on one side and looking through the filter from the other side. Check thoroughly for holes or tears in the filter.
 - (5) Install cleaned or new filter.
 - (6) Close and secure filter access door.
 - (7) Install lower engine cowl.
 - (8) Close and secure upper engine cowl.

**AA-5 SERIES
MAINTENANCE MANUAL**

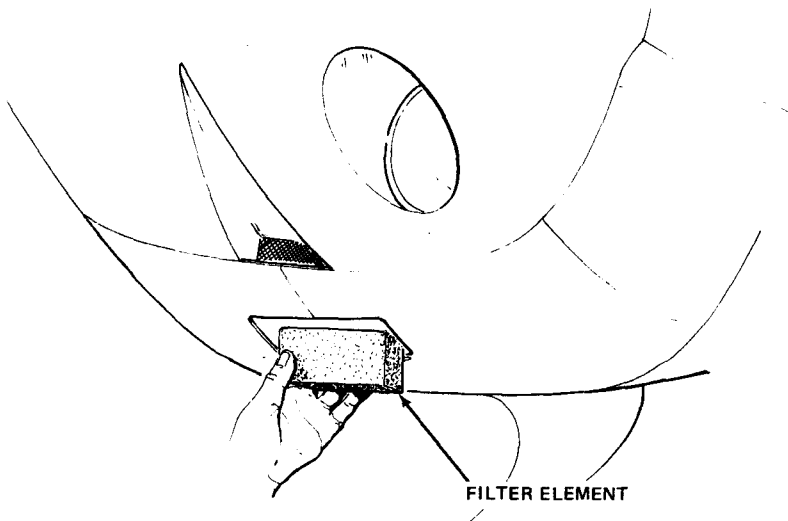
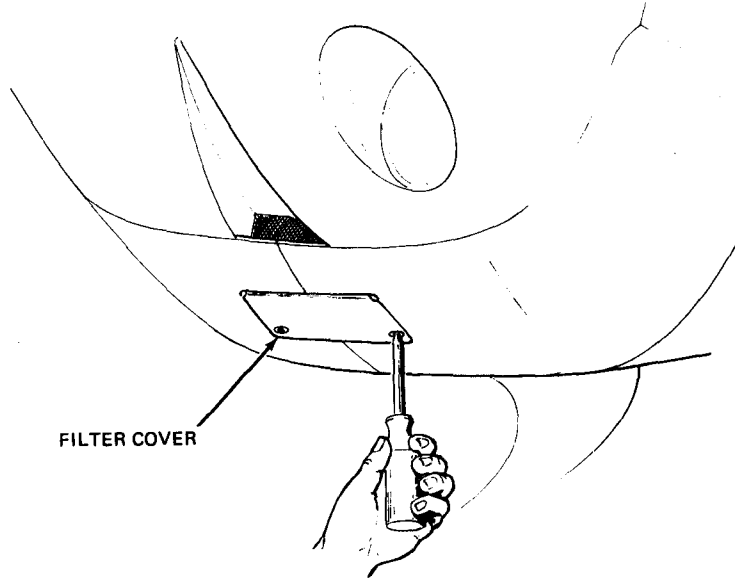

3472

**Air Filter Servicing (AA5-0641 and AA-5A Aircraft)
Figure 6**

AA-5 SERIES
MAINTENANCE MANUAL

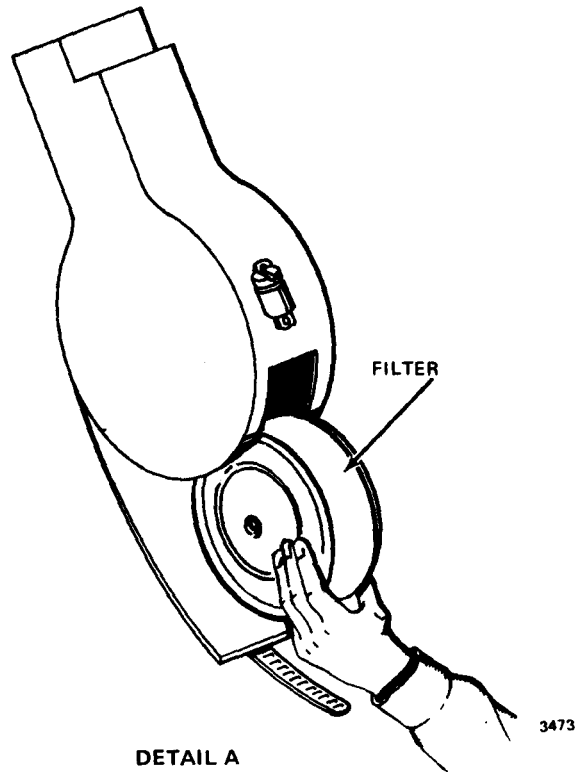
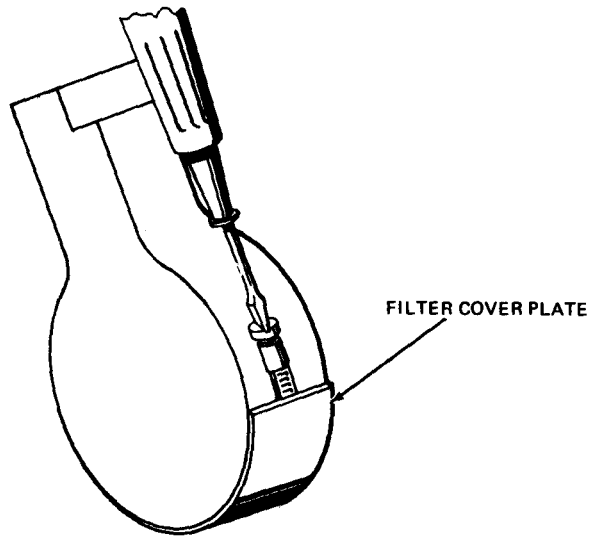
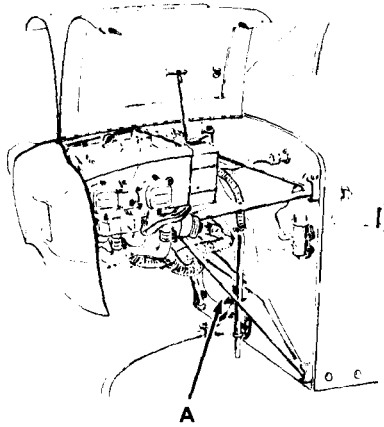

DETAIL A

Engine Air Filter Servicing (AA-5B Aircraft)
Figure 7

6. Vacuum System Air Filter Servicing

The vacuum system air filter (Figure 8) is located beneath the instrument panel, and attached to the inside of the firewall near its center. The filter elements of both the air filter and the regulator should be checked periodically to ensure that they are not clogged by dirt or foreign material. If either of the filter elements are dirty and appear to be clogged, they should be replaced. The air filter element should be replaced by Part No. 1J7-1 or EBG03-0003. The regulator filter element should be replaced by Part No. B3-5-1.

Replace the filter elements as follows:

NOTE: Never blow off filter with compressed air or attempt to wash element in any liquid or soak in oil.

- A. Locate air filter and regulator per Figure 8. Remove fastener attaching filter to firewall.

NOTE: Do not disconnect vacuum hoses from filter unless hoses are to be replaced.

- B. Remove the nut and washer as shown in Figure 8.
C. Remove old filter element and replace with new element.
D. Reinstall washer and nut.
E. Reconnect air filter to firewall.

To replace regulator filter, proceed as follows:

- F. Remove screw in top of regulator (Figure 8) and remove regulator cover.
G. Remove old filter element and replace with new element.
H. Reinstall cover and secure with screw.

7. Airframe Lubrication

Lubricate the airframe in accordance with Section 12-0, Figure 1, this chapter. During airframe lubrication, observe the following precautions and procedures:

WARNING: USE CLEANING SOLVENT IN A WELL VENTILATED AREA. AVOID BREATHING FUMES. KEEP AWAY FROM FLAMES.

CAUTION: SYNTHETIC COMPOUNDS SUCH AS THOSE FOUND IN AIRCRAFT OILS AND GREASES CONTAIN ELEMENTS WHICH CAN SOFTEN PAINT, NATURAL RUBBER, NEOPRENE, AND SOME ELECTRICAL INSULATORS. IF THIS TYPE LUBRICANT IS SPILLED ON ANY OF THESE MATERIALS, WIPE IT OFF IMMEDIATELY AND THOROUGHLY WITH A CLEAN CLOTH.

- A. Remove all foreign matter from joints, fittings, or bearing surfaces immediately before application of lubricant. Use a clean cloth saturated with a cleaning solvent.
B. Apply lubricant sparingly to prevent accumulation of contaminants.
C. Main gear and nose gear bearings. (See Figure 9).

AA-5 SERIES
MAINTENANCE MANUAL

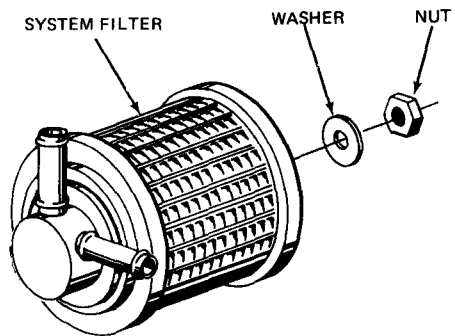
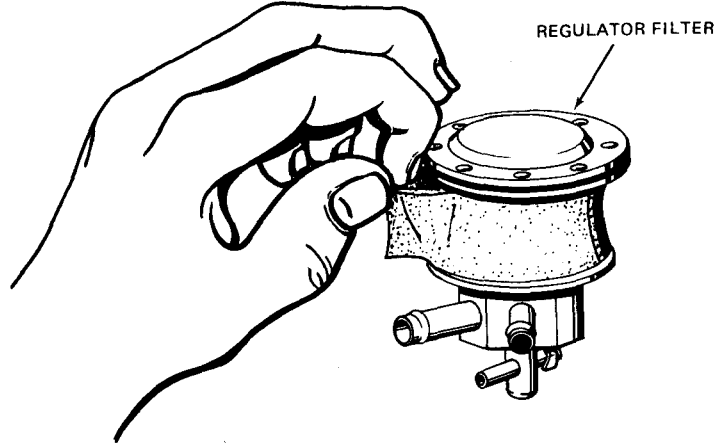

Vacuum System Air Filter Servicing
Figure 8

AA-5 SERIES
MAINTENANCE MANUAL

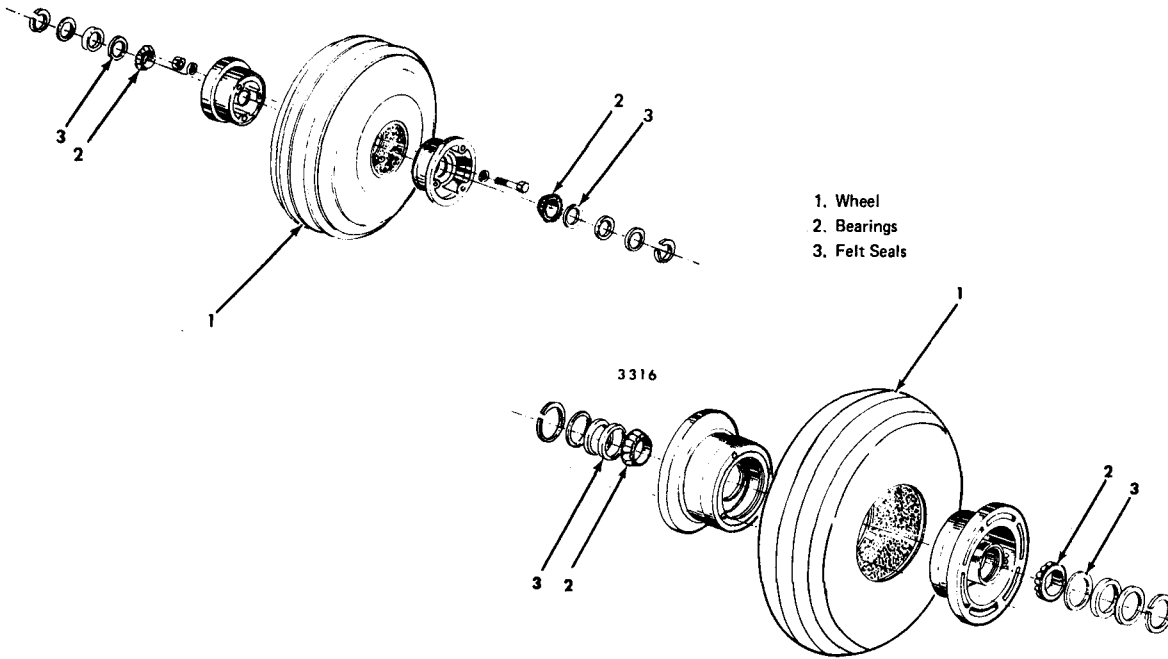

Wheel Bearing Lubrication
Figure 9

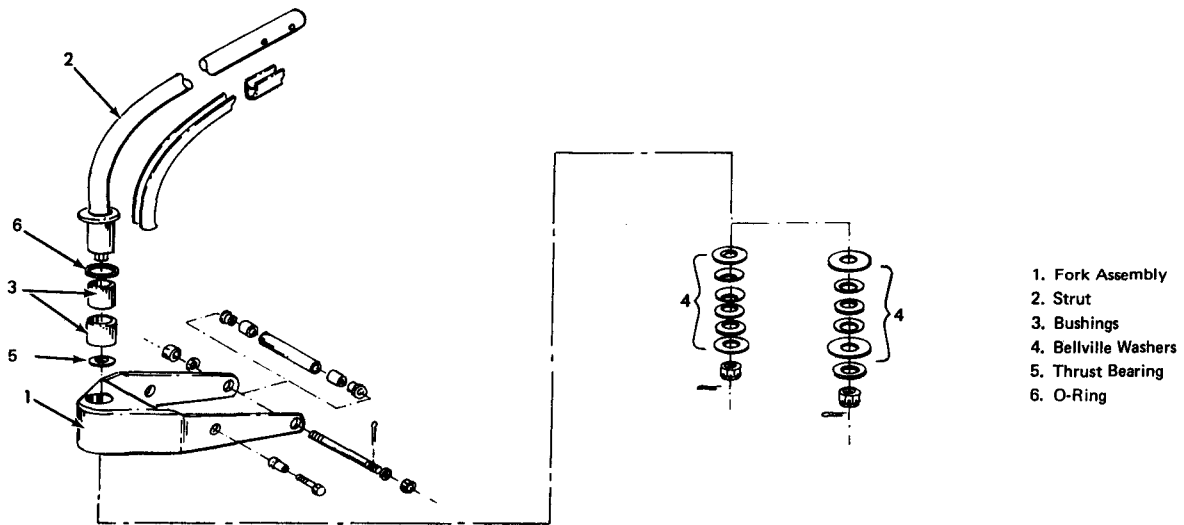

3314

Nose Gear Fork Assembly Servicing
Figure 10

WARNING: USE CLEANING SOLVENTS IN A WELL VENTILATED AREA. AVOID BREATHING FUMES. KEEP AWAY FROM FLAMES.

CAUTION: DO NOT SPIN BEARINGS WHEN DRYING WITH COMPRESSED AIR. WASH BEARING SEALS IN STODDARD SOLVENT (P-S-661 OR EQUIVALENT) AND DRY WITH A CLEAN, SOFT CLOTH.

CAUTION: USE A CLEAN, LINT-FREE CLOTH TO CLEAN AND HANDLE BEARINGS. DO NOT USE A DIFFERENT TYPE GREASE IN WHEEL BEARINGS.

(1) Clean and repack wheel bearings after the first 100 hours of operation. Thereafter clean and repack at each tire change. Remove wheels (1) and bearings (2). Clean wheel bearings and felt seals (3) with Stoddard solvent (P-S-661) or equivalent and dry with soft lint-free cloth.

(2) Inspect bearings (2) and races for wear or damage and replace if necessary.

NOTE: For adjustment of nose wheel and main landing gear bearings, refer to Chapter 32.

(3) Repack bearings only with grease MIL-G-25760 (Section 12-0, Figure 2) and lubricate felt seals with oil MIL-L-7870 (Section 12-0, Figure 2) before installation.

D. Nose gear fork assembly (See Figure 10.)

WARNING: USE CLEANING SOLVENT IN A WELL VENTILATED AREA. AVOID BREATHING FUMES. KEEP AWAY FROM FLAMES.

(1) Clean and grease the nose gear fork assembly, bushings, and Bellville washers every 100 hours. Remove nose gear fork assembly (1) from strut (2), clean bushings (3), Bellville washers (4) and fork (1) with Stoddard solvent (P-S-661) or equivalent and dry with soft lint-free cloth.

(2) Inspect bushings (3), thrust bearings (5), and Bellville washers (4), for wear or damage and replace if necessary.

NOTE: For adjustment of nose gear fork assembly, refer to Chapter 32.

(3) Repack nose gear fork assembly, bushings, thrust bearing and Bellville washers only with grease MIL-G-7711 (Section 12-0, Figure 2) before installation.

E. T-Column Bearings

The T-column needle and thrust bearings should be lubricated when evidence of binding occurs, or when the assembly must be disassembled for repair or replacement of parts. Lubricate the bearings as follows:

CAUTION: DO NOT HANDLE BEARINGS WITH BARE HANDS. USE CLEAN LINT-FREE CLOTH.

(1) Remove the needle and thrust bearings.

WARNING: USE CLEANING SOLVENT IN A WELL VENTILATED AREA. AVOID BREATHING FUMES. KEEP AWAY FROM FLAMES.

(2) Clean the bearings and races with Stoddard solvent (P-S-661) or equivalent and dry with soft lint-free cloth.

- (3) Visually inspect bearings and races for wear or damage and replace if necessary.

NOTE: For adjustment of T-column, refer to Chapter 27.

- (4) Repack bearings only with MIL-G-7711 (Section 12-0, Figure 2) grease before installation.

F. Trim Wheel Gears

- (1) Use a clean lint-free cloth to wipe excess grease and foreign material from shaft.
- (2) Apply a thin coating of MIL-G-7711 (Section 12-0, Figure 2) grease to the shaft by hand.

G. Trim Actuator Shaft

- (1) Use a clean lint-free cloth to wipe excess grease and foreign material from shaft.
- (2) Apply a thin coating of MIL-G-7711 (Figure 2) grease to the shaft by hand.

H. Canopy and Baggage Door Latches

WARNING: USE CLEANING SOLVENT IN A WELL VENTILATED AREA. AVOID BREATHING FUMES. KEEP AWAY FROM FLAMES.

The canopy and baggage door latches should be lubricated at each 100-hour inspection or when they must be disassembled for repair. Lubricate the latches as follows:

- (1) Clean internal parts of latch with Stoddard solvent (P-S-661 or equivalent) and dry with soft lint-free cloth.
- (2) Inspect parts for wear and damage. Replace if necessary.

NOTE: For adjustment of canopy and baggage door latches, refer to Chapter 52.

- (3) Lubricate latch parts with a light coating of Lubriplate #50 white grease or equivalent, before assembly.

I. Flap Position Indicator Cable

The flap position indicator cable should be lubricated when evidence of binding occurs or when it is removed for maintenance. Lubricate the cable as follows:

- (1) Use a clean lint-free cloth to wipe excess grease and foreign material from cable.
- (2) Apply a thin coating of MIL-G-21164 (Section 12-0, Figure 2) Molybdenum Disulphide grease to the cable by hand.

8. Auxiliary Fuel Pump Filter Servicing

Clean the auxiliary fuel pump filter as follows:

WARNING: PRIOR TO REMOVING FILTER FROM FUEL PUMP, CLOSE AND LOCK CANOPY, OR OTHERWISE ENSURE THAT PUMP IS NOT ENERGIZED WHILE FILTER IS REMOVED. ENERGIZING PUMP WITH A FILTER REMOVED WILL RESULT IN RAW FUEL BEING PUMPED INTO THE ENGINE COMPARTMENT.

- A. Locate auxiliary fuel pump (1, Figure 11), cut safety wire and remove bottom cover (2), from pump (1), by turning it counterclockwise.
- B. Remove filter element (3) from fuel pump, and remove magnet (4), and gasket (5) from bottom cover.
- C. Use compressed air and a clean, lint-free cloth to remove foreign material from filter (3), magnet (4), and gasket (5).

NOTE: If excessive amounts of foreign material are found in the filter, the Fuel System should be checked for contamination as shown in Chapter 28.

AA-5 SERIES
MAINTENANCE MANUAL

- D. Reinstall filter element (3) in pump (1), and magnet (4), and gasket (5) in bottom cover (2).
- E. Install bottom cover (2) on pump (1), by pressing slots over lugs and rotating cover clockwise into detent.
- F. Safety wire bottom cover on pump with .032 inch wire.
- G. Energize auxiliary fuel pump and check for leakage around bottom cover.

- 1. PUMP
- 2. BOTTOM COVER
- 3. FILTER ELEMENT
- 4. MAGNET
- 5. GASKET
- 6. 5/8 INCH WRENCH

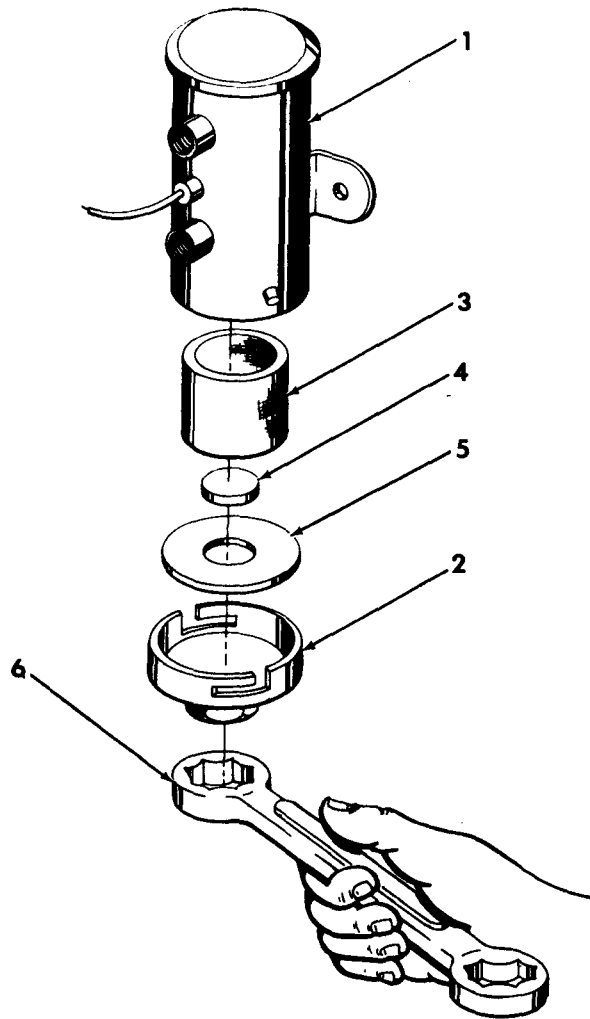

Auxiliary Fuel Pump Servicing
Figure 11

AA-5 SERIES
MAINTENANCE MANUAL

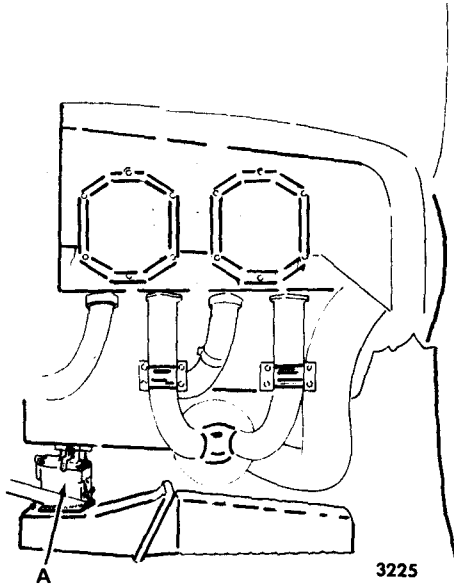

AA-5 AND AA-5A

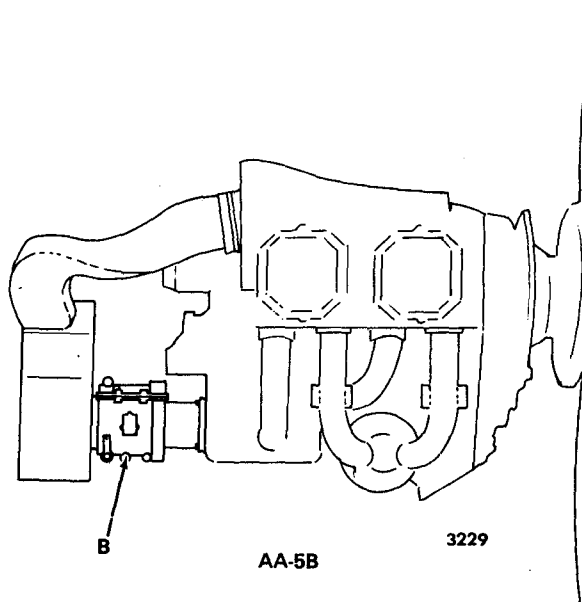
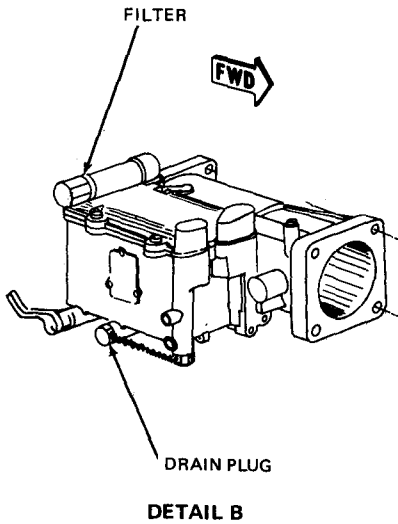
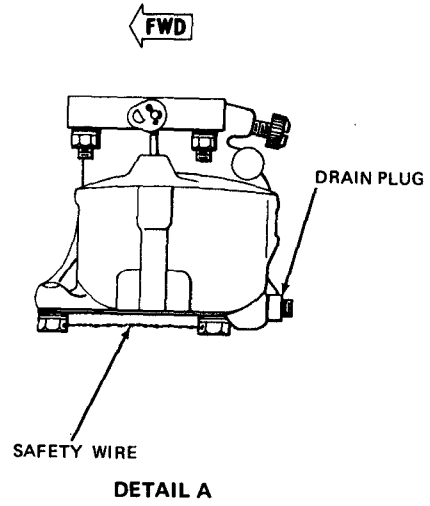

Carburetor Filter Servicing
Figure 25

J. Carburetor Filter Servicing

Drain carburetor bowl and clean carburetor filter as follows:

WARNING: WHEN THE DRAIN PLUG IS REMOVED FROM THE CARBURETOR BOWL, A SMALL AMOUNT OF FUEL WILL DRAIN FROM THE CARBURETOR. CATCH THIS FUEL IN A CONTAINER FOR PROPER DISPOSAL.

- (1) Cut the safety wire on the carburetor (See Figure 12) between the filter and the bowl drain plug.
- (2) Remove the bowl drain plug, and catch the fuel that drains from the carburetor in a suitable container.
- (3) When the carburetor bowl has drained, replace the plug.
- (4) Remove filter and clean with compressed air.
- (5) Install filter.
- (6) Install 0.032 inch safety wire on filter and bowl drain plug.

UNSCHEDULED SERVICING

1. General

This section provides procedures required to be performed in the event of unusual environmental conditions, and other servicing procedures which are performed as required rather than on a regularly scheduled basis.

2. Ice and Snow Removal

Accumulations of ice and snow on the aircraft can result in damage during ground handling, and can constitute a flight hazard if not completely removed. Ice and snow removal can result in damage to the aircraft if the right methods are not employed. Taxiing or towing through snow or slush can result in ice formation on wheels, brake parts, and fairings during freezing weather. Subsequent attempts to move the aircraft without clearing this ice may damage the wheels or fairings.

The recommended method of ice and snow removal is to allow it to melt. Remove as much snow as possible with a soft bristle boom, make sure the wheels and brakes are clear, and tow the aircraft into a heated hangar. This method is particularly desirable, since it will melt any undetected ice and snow that could constitute a flight hazard.

If heated facilities are not available, ice must be carefully removed with wooden or plastic scrapers, or by hand.

CAUTION: DO NOT USE SOLVENTS, ALCOHOL, ETHYLENE GLYCOL (ANTI-FREEZE), OR ANY PETROLEUM DERIVATIVE FOR ICE OR SNOW REMOVAL. THESE SUBSTANCES CAN DAMAGE PAINT, PLEXIGLAS, RUBBER, AND PLASTICS, AND CAN REMOVE LUBRICANTS.

Make sure ice and snow accumulations have been removed from the following areas:

- A. Wings, empennage, and all control surfaces.
- B. Between the wing trailing edges and the leading edges of the flaps and ailerons.
- C. Pitot tube and fuel tank vents.
- D. Propeller spinner (inside and outside).
- E. Nose cowling air intakes.
- F. Landing light.
- G. Propeller blades.
- H. Engine oil breather pipe.
- I. Windshield, canopy, and canopy tracks.
- J. Wheels, brakes, and wheel fairings.

NOTE: Taxiing or towing through snow and slush can result in the accumulation of ice in the wheel fairings and on wheels and brake parts during freezing weather.

- K. Between rudder and vertical stabilizer.
- L. Between elevators and horizontal stabilizer
- M. Between elevator and trim tab.
- N. Around rudder, elevator, and elevator trim tab linkages.

3. Battery Servicing and Charging

Refer to Chapter 24 for battery servicing and charging procedures.

4. External Cleaning

The painted surfaces of the aircraft have a long lasting, all-weather finish and should require no buffing or rubbing out in normal conditions. However, it is desirable to wash and polish it to preserve the outstanding exterior finish. It is recommended that wax or polish operations be delayed (at least 60 days after date of certification) to allow proper curing of paint. The paint can be kept bright simply by washing with water and mild soap. Avoid abrasive or harsh detergents. Rinse with clear water and dry with terry cloth towels or chamois. Oil and grease spots may be removed with kerosene or mineral spirits.

NOTE: No commercial paint removers are to be used on any airframe components unless specific prior approval has been received from the factory. (See Chapter 20.)

If you choose to wax your aircraft, use a good automotive-type wax applied as directed. The use of wax in areas subject to high abrasion, such as leading edges of wings and tail surfaces, propeller, spinner, and blade, is recommended.

5. Internal Cleaning

Clean the interior regularly with a vacuum cleaner to remove dust and loose dirt from the upholstery and carpet.

CAUTION: THE APPLICATION OF CERTAIN CLEANING AGENTS, PROTECTIVE COATINGS, STAIN REPELLENTS, AND OTHER CHEMICAL COMPOUNDS MAY REDUCE THE FIRE RETARDANT QUALITIES OF INTERIOR FABRICS. CONSULT THE COMPOUND MANUFACTURER BEFORE USE.

If liquid (coffee, etc.) is spilled on the upholstery or carpet, blot it up promptly with cleansing tissue or rags. Continue blotting until no more liquid is taken up. Sticky materials may be cleaned with household spot removers, used sparingly. Before using any solvent, read the instructions on the container and test it on an obscure place on the fabric to be cleaned. Never saturate the fabric with a volatile solvent: it may damage the padding and backing materials.

WARNING: USE STODDARD SOLVENT IN A WELL VENTILATED AREA. AVOID BREATHING FUMES. KEEP AWAY FROM FLAMES.

CAUTION: NEVER USE GASOLINE, BENZINE, ALCOHOL, ACETONE, CARBON TETRACHLORIDE, FIRE EXTINGUISHER FLUID, ANTI-ICE FLUID, LACQUER THINNER, OR GLASS CLEANER TO CLEAN PLASTIC. THESE MATERIALS WILL DAMAGE THE PLASTIC AND MAY CAUSE SEVERE CRAZING.

The plastic trim, headliner, instrument panel, and control knobs can be cleaned with a cloth moistened with Stoddard solvent, (P-S-661) or equivalent.

6. Windshield and Window Cleaning

In order to maintain good visibility at all times, the Plexiglas in the windshield, windows, and canopy should be given good care and kept clean at all times. Techniques and materials used to clean glass should be avoided since Plexiglas is softer than glass and subject to damage by solvents and abrasive glass cleaning agents.

A. Precautions

- (1) Cleaning agents should be limited to soap and water applied with a sponge or wadding of soft cloth. Most solvents will cloud plastic and may cause cracking and crazing. Many commercial glass cleaners contain abrasives and solvents which may cause damage.
- (2) Do not use burlap, duck, canvas, or other harsh cloths on Plexiglas. Use only cotton or soft linen cloths and rinse them out frequently.
- (3) Do not rub on the Plexiglas. Mud, dirt, and other foreign matter dislodged and trapped beneath the cloth or sponge will cause fine scratches in the surface.

CAUTION: NEVER USE GASOLINE, BENZINE, ALCOHOL, ACETONE, CARBON TETRACHLORIDE, FIRE EXTINGUISHER FLUID, ANTI-ICE FLUID, LACQUER THINNER OR GLASS CLEANER TO CLEAN PLASTIC. THESE MATERIALS WILL DAMAGE THE PLASTIC AND MAY CAUSE SEVERE CRAZING.

B. Recommended Procedures

- (1) Flush the area to be cleaned with a solution of mild soap and water. Wait a few moments to allow the soap to work.
- (2) Flood the area with clear water. Use the stream of water and the hands to dislodge dirt accumulations.
- (3) After all dirt and grit have been removed, apply soap and water again. Go over the area lightly with a sponge or heavy wadding of soft cloth, followed by flooding with clean water. Rinse the cloth or sponge frequently.
- (4) A soft cloth soaked in kerosene may be used to remove heavy grease and tar.
- (5) After cleaning, allow the Plexiglas to air dry. Remove any water spots with a damp cloth.
- (6) After cleaning, a thin coat of hard polish wax may be applied in accordance with the manufacturer's directions. Buff lightly with a soft cloth.
- (7) Jeweler's rouge may be used to work out or reduce scratches and other marks. Follow the manufacturer's directions. Apply wax and buff when finished.

7. Engine Cleaning

WARNING: USE STODDARD SOLVENT IN A WELL VENTILATED AREA. AVOID BREATHING FUMES. KEEP AWAY FROM FLAMES.

CAUTION: PARTICULAR CARE SHOULD BE TAKEN TO PROTECT ELECTRICAL EQUIPMENT BEFORE CLEANING. SOLVENT SHOULD NOT BE ALLOWED TO ENTER MAGNETOS, STARTER OR ALTERNATOR. COVER ANY FUEL, OIL, AND AIR OPENINGS ON THE ENGINE AND ACCESSORIES BEFORE WASHING THE ENGINE WITH SOLVENT. CAUSTIC CLEANING SOLUTIONS SHOULD BE USED CAUTIOUSLY AND SHOULD ALWAYS BE PROPERLY NEUTRALIZED AFTER THEIR USE.

The engine should be cleaned with a suitable solvent, such as Stoddard solvent, (P-S-661) or equivalent, then dried thoroughly. If caustic or emulsifying cleaners are used, they should be flushed with water and neutralized as soon as possible after cleaning is accomplished.

8. Propeller Care

Nicks, gouges, and other damage to the propeller should receive immediate attention. Refer to Chapter 61.

WARNING: USE SOLVENT IN A WELL VENTILATED AREA. AVOID BREATHING FUMES. KEEP AWAY FROM FLAMES.

Cleaning agents such as mineral spirits may be used to clean the propeller, but do not allow the solvent to flow into the spinner. Any residue will be blown aft over the aircraft when the engine is started. The blade should be coated with a light film of oil, or waxed if desired.

Tighten or replace any loose or missing spinner attaching parts. Replace the spinner if it sustains any damage.

**AA-5 SERIES
MAINTENANCE MANUAL**

**CHAPTER 20
STANDARD PRACTICES — AIRFRAME
TABLE OF CONTENTS**

| NUMBER | PAGE |
|---|-------------|
| 20-1-0 AIRFRAME STRUCTURAL REPAIR | |
| Description | 1 |
| General | 1 |
| Tools, Jigs, and Fixtures | 1 |
| Materials | 1 |
| Service Kits | 1 |
| Sheet Metal Repairs (Riveted) | 1 |
| Honeycomb Panel Repairs (Riveted) | 1 |
| Repair of Formed Thermo-Plastic Parts | 2 |
| Engine Mount Repair | 2 |
| Control Surface Repair | 2 |
| Bondline Damage and Repair | 5 |
| Non-Repairable Parts | 5 |
| Rivet Substitution | 5 |
| Primary Structures | 6 |
| 20-1-1 AIRFRAME STRUCTURAL REPAIR | |
| Approved Repairs | 801 |
| Leading Edge Repair | 801 |
| Wing Rib Repair | 801 |
| Honeycomb Repair, Partial Core Damage | 802 |
| Honeycomb Repair, Extensive Core Damage | 802 |
| Honeycomb Repair, Forward Fuselage Section (Model AA-5) | 803 |
| Bonding Strap Angle Splice | 809 |
| Honeycomb Repair, Lower Engine Mount Area (Model AA-5) | 811 |
| Honeycomb Repair, Upper Engine Mount Area (Model AA-5) | 811 |
| Honeycomb Panel Replacement (Station 50) | 814 |
| Upper Forward Fuselage Assembly Replacement | 814 |

**AA-5 SERIES
MAINTENANCE MANUAL**

| NUMBER | PAGE |
|---|-------------|
| Aft Fuselage Assembly Replacement | 817 |
| Aft Fuselage Bulkhead Replacement (Model AA-5 only) | 820 |
| Bondline Repair | 828 |
| Main Gear Strut Repair | 828 |
| Damaged or Delaminated Spar Collar Repair | 829 |
| 20-2-0 PREPARATIONS FOR PAINTING | |
| Description | 1 |
| General | 1 |
| Cleaning/Painting | 701 |
| Stripping and Cleaning Procedure | 701 |
| Metal Conditioner Application | 704 |

**AA-5 SERIES
MAINTENANCE MANUAL**

AIRFRAME STRUCTURAL REPAIR — DESCRIPTION

1. General

The information in this section should be used in conjunction with the AC43.13-1A "Acceptable Methods, Techniques and Practices — Aircraft Inspection and Repair." Information contained herein is applicable to repair of damage where replacement of the damaged assembly is considered unnecessary. If some doubt exists relative to repair not specifically covered, consult the Grumman American Customer Service Department.

Field repairs of bonded structures can be made using rivets. Flush riveted repairs can be made in both sheet metal and honeycomb areas. These repairs are normally covered with an epoxy filler to maintain surface contour and smoothness.

2. Tools, Jigs, and Fixtures

Very few special tools are required for normal maintenance on the AA-5, AA-5A, and AA-5B. Standard shop tools (including a torque wrench and micrometer) are usually adequate. Required special tools, jigs, and fixtures can be procured through your authorized Grumman American Dealer or Distributor. Special tools are listed in Chapter 12.

3. Materials

Structural repairs should be accomplished using identical material to that being repaired (i.e., 0.032-inch 2024-T3 Clad Aluminum). Figure 1 shows the various materials utilized and should be used in determining type of material for all repair work. If material shortages make substitution necessary, 2024-T3 in most cases can be substituted for any other aluminum alloys. However, it is important that the 2024-T3 aluminum contain an aluminum coating (designated as "Alclad") for corrosion protection.

4. Service Kits

Service Kit No. SK-102A is a potting kit for honeycomb repair and Service Kit No. SK-125 is a bondline repair kit used for the repair of delaminated metal-to-metal bond joints. Both kits contain instructions for proper preparation and application and are available through your authorized Grumman American Dealer or Distributor.

5. Sheet Metal Repairs — Riveted

Damage to skin, ribs, and frame areas can generally be repaired using normal sheet metal repair techniques. These are covered in AC43.13-1A. Several typical repairs are also discussed in Approved Repairs, Paragraphs 1 and 2. Complete fuselage sections can be replaced using standard rivet practices as discussed in Paragraphs 10, 11, and 13. Local wing skin damage can be satisfactorily repaired using rivets. However, if extensive wing skin damage exists, it is recommended that the complete skin panel be replaced. The Grumman American Customer Service Department should be contacted for additional information.

NOTE: Repair of the wing in the fuel tank area is not authorized.

6. Honeycomb Panel Repairs — Riveted

Damage to honeycomb panels can be repaired by removal of the damaged section, sealing any exposed honeycomb core with PR1436GB-2 Inhibited Sealant, and splicing in of new repair parts. The splice can be installed with rivets and can be made flush with the external surface if desired. Representative repairs for damaged honeycomb panels are discussed in Approved Repairs, Paragraph 3 through 8.

NOTE: PR1436GB-2 Inhibited Sealant is approved and is available through Products Research and Chemical Corporation, 2919 Empire Avenue, Burbank, California or through your authorized Grumman American Dealer or Distributor.

AA-5 SERIES
MAINTENANCE MANUAL

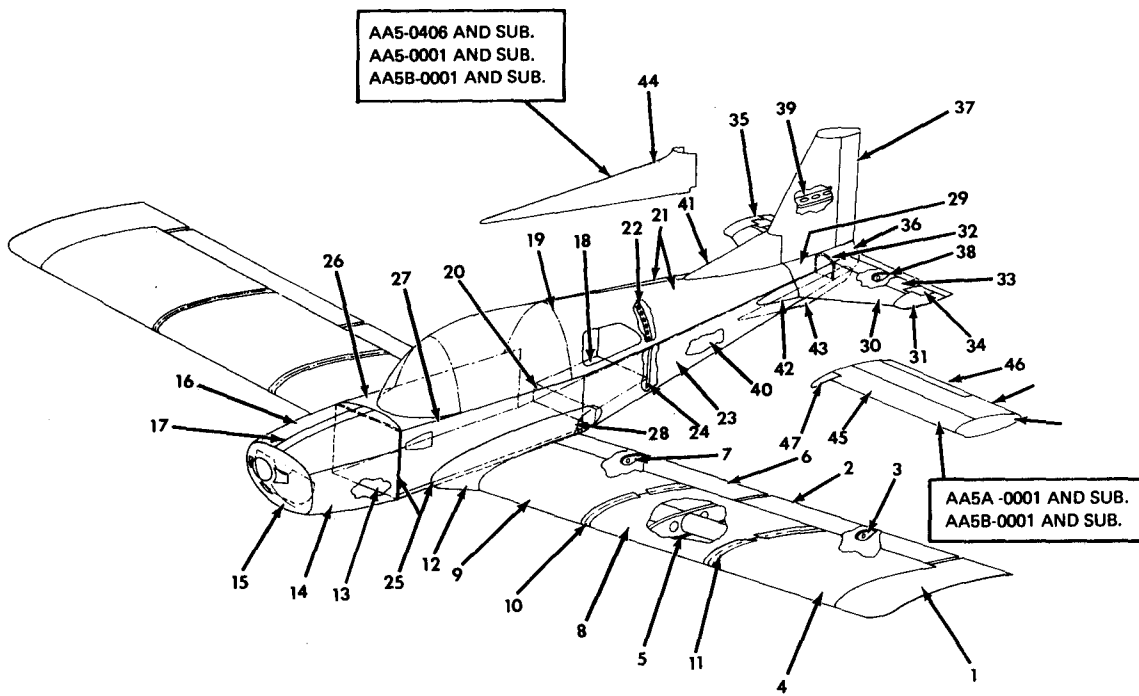

1025

Airframe Materials Chart (Sheet 1 of 2)
Figure 1

**AA-5 SERIES
MAINTENANCE MANUAL**

| <u>ITEM NO.</u> | <u>DESCRIPTION</u> | <u>MATERIAL</u> | <u>ITEM NO.</u> | <u>DESCRIPTION</u> | <u>MATERIAL</u> |
|-----------------|--------------------|---|-----------------|--------------------|--|
| 1 | Wing Tip | Fiberglass | 24 | Stiffener | .032" 2024-T3 Alclad |
| 2 | Aileron Skin | .016" 2024-T3 Alclad | 25 | Angles | .025" 2024-T3 Alclad |
| 3 | Aileron Rib | .50" Honeycomb | 26 | Skin | .025" 6061-T4 |
| 4 | Wing Skin | .020" 2024-T3 Alclad | 27 | Fuselage Panels | .50" Honeycomb |
| 5 | Wing Rib | .025" 6061-T6 | 28 | Gusset | .40" 2024-T42 Alclad (AA5-0001 & Sub) |
| 6 | Flap Skin | .032" 2024-T3 Alclad | | | .063 2024-T42 Alclad (AA5A-0001 & Sub & AA5B-0095 & Sub) |
| 7 | Flap Rib | .50" Honeycomb | | | .063 4130 Cond (AA5B-0001 thru AA5B- 0094) |
| 8 | Wing Skin | .025" 2024-T3 Alclad | 29 | Cover | .020" 2024-T3 Alclad |
| 9 | Wing Skin | .032" 2024-T3 Alclad (Model AA-5 & AA-5A Std) .025" 2024-T3 Alclad (Model AA-5B & AA-5A Opt.) | 30 | Stabilizer Skin | .020" 2024-T3 Alclad |
| 10 | Doubler | .025" 2024-T3 Alclad | 31 | Stabilizer Tip | Thermo-Plastic |
| 11 | Doubler | .025" 2024-T3 Alclad | 32 | Bulkhead | .090" 2024-T42 Alclad |
| 12 | Wing Root Fairing | Fiberglass | 33 | Elevator Skin | .016" 2024-T3 Alclad |
| 13 | Firewall | .018" Aluminized Steel | 34 | Extension Skin | .032" 2024-T3 Alclad |
| 14 | Lower Cowl | .032" 6061-T6 (AA5-0001 thru AA5- 0640) .032" 6061-T4 (AA5-0641 & Sub, AA5A -0001 & Sub, AA5B-0001 & Sub) | 35 | Trim Tab Skin | .025" 2024-T3 Alclad |
| 15 | Nose Cowl | Fiberglass | 36 | Tailcone | Thermo-Plastic |
| 16 | Upper Cowl | .025" 6061-T6 Alclad (AA5-0001 thru AA5-0640) .032" 6061-T4 (AA5- 0641 & Sub, AA5A-0001 & Sub, AA5B-0001 & Sub) .032" 5052-H32 | 37 | Rudder Skin | .016" 2024-T3 Alclad |
| 17 | Baffle | .032" 5052-H32 | 38 | Elevator Rib | .50" Honeycomb |
| 18 | Baggage Floor | .032" 2024-T3 Alclad | 39 | Stabilizer Rib | .025" 2024-T42 Alclad |
| 19 | Bulkhead | .032" 2024-T3 Alclad | 40 | Bottom Skin | .025" 2024-T3 Alclad |
| 20 | Bulkhead | .032" 2024-T3 Alclad | 41 | Dorsal Fin | .025" 2024-T3 Alclad |
| 21 | Skin | .020" 2024-T3 Alclad | 42 | Horizontal Fillet | .032" 2024-T3 Alclad |
| 22 | Bulkhead | .025" 2024-T42 Alclad | 43 | Ventral Fin | .50" Honeycomb (Model AA5 only) |
| 23 | Side Skin | .032" 2024-T3 Alclad | 44 | Dorsal Fin | Thermo-Plastic |
| | | | 45 | Stabilizer Skin | .016" 2024-T3 Alclad (AA5B-0001 thru AA5B -0077) |
| | | | 46 | Trim Tab Skin | .020" 2024-T3 Alclad |
| | | | 47 | Horizontal Fillet | Thermo-Plastic |

Airframe Materials Chart (Sheet 2 of 2)
Figure 1

AA-5 SERIES
MAINTENANCE MANUAL

Critical honeycomb areas are those areas within 6 inches of the wing spar and within 4 inches of the engine mount, tail cone, and nose gear structures. Minor damage to one face sheet of a honeycomb panel which is confined to an area of 1.0 inch or less in diameter, and located in a non-critical area, can be repaired by smoothing sharp edges in the damaged area, sealing any exposed honeycomb core with PR 1436GB-2 sealant and filling with an epoxy filler.

Minor damage to a critical area which is equal to or less than 1.0 inch in diameter can be repaired by removal of the damaged face sheet, sealing any exposed honeycomb core with PR1436GB-2 sealant, application of a resin filler, and installation of a doubler plate. Service Kit No. SK-102A includes an acceptable resin filler with resin, hardener, and instructions for preparation and application. It is available through your authorized Grumman American Dealer or Distributor. A representative repair is discussed in Approved Repairs, Paragraph 3.

Damaged areas greater than 1.0 inch in diameter or including punctures through both face sheets will require removal of the damaged area and insertion of a honeycomb repair section. Typical repairs are discussed in Approved Repairs, Paragraph 4.

Extensive honeycomb panel damage, such as in the nose gear attachment area can be repaired by splicing in new honeycomb repair assemblies which are available through your authorized Grumman American Dealer or Distributor. Such a repair is discussed in Approved Repairs, Paragraphs 5 and 8.

When making honeycomb panel repairs which require splicing of the bonding strap angles located at the lower corners of the fuselage, the splice must be so designed to maintain the continuity of the angles from the original panel into the repair panel. This can be achieved with angles riveted over the bonding strap angles across the splice. This is discussed in Approved Repairs, Paragraph 6. The length of the external splice angle can be increased as required for appearance purposes.

All riveted honeycomb repairs must include some means of sealing the repair joint from external moisture. This protection is provided by PR1436GB-2 Inhibited Sealant. Epoxy filler may be used to smooth the repair prior to painting.

All honeycomb edges and repair faying surfaces should be coated with PR1436GB-2 sealant. Also, all rivets should be dipped in this sealant prior to installation. After completion of the repair, the repaired area should be coated with zinc chromate primer.

7. Repair of Formed Thermo-Plastic Parts

Repairs of punctures may be accomplished by cutting out the damaged area, removing the paint and installing an overlapping or flush patch of identical material. A doubler may be added behind the patch if additional strength is required. The bonding agent can be Trichloroethane or a suitable substitute.

WARNING: WHEN USING TRICHLOROETHANE, ENSURE THAT THE WORKING AREA IS WELL VENTILATED AND THAT PROTECTIVE EQUIPMENT (GLOVES, EYE PROTECTION) IS WORN. AVOID BREATHING FUMES. KEEP AWAY FROM FLAMES.

Cracks or voids may be repaired by applying a filler composed of solvent and material shavings. Upon completion of the repair, sand the area smooth and repaint. Extensively damaged parts should be replaced.

8. Engine Mount Repair

Engine mount repairs should be accomplished in strict accordance with Part 43 of the Federal Aviation Regulations. Repair details for the repairs of damaged honeycomb in the areas adjacent to the two upper and lower engine mount extrusions on the Model AA-5 are given in Approved Repairs, Paragraphs 7 and 8.

9. Control Surface Repair

After repair or repainting of any control surface, it is necessary to check the balance and adjust the mass balance weight as required to bring it within tolerance as follows:

**AA-5 SERIES
MAINTENANCE MANUAL**

| | AA-5 | AA-5A & AA-5B |
|--------------------|-------------------|-------------------|
| Elevator | +3 to +6 in. lbs. | -1 to -5 in. lbs. |
| Rudder | -2 to +1 in. lbs. | -2 to 0 in. lbs. |
| Ailerons | -1 to +2 in. lbs. | -1 to +2 in. lbs. |

A control surface which is leading edge heavy is referred to as "overbalanced" and referred to by (-). Refer to Chapter 27 for control system balancing and rigging.

10. Bondline Damage and Repair

A. Types of Bondline Damage

(1) Physical Damage

The most common type of bondline damage is physical damage along the trailing edges of the flaps, ailerons, elevators and rudder. This is usually caused by persons stepping on the in-board trailing edges of the flaps and general "hangar rash" on the other control surfaces. This type of damage is usually readily visible in the form of joint separation. A typical bondline repair procedure is discussed in Approved Repairs, Paragraph 13.

(2) Corrosion Damage

A less common type of bondline damage is damage caused by metal corrosion. This type of damage is usually restricted to edges of unfilleted bondlines, such as the trailing edges of wings, rudders, elevators, and trim tabs, particularly if these edges are not well protected by paint. This type of damage is more likely in tropical and subtropical climates, particularly where an aircraft is located close to the coast.

B. Areas Requiring Inspection Emphasis

Areas which should be given particular attention include: flanges of wing and stabilizer rear spars, trailing edges of control surfaces, the side lap joint between the tailcone and forward cabin section, the joint between the tailcone top and side skin, and the aft tailcone bulkhead joints.

Inside edges and internal joints which have an undisturbed bondline fillet are generally not affected. See Approved Repairs, Paragraph 13.

11. Non-Repairable Parts

The following parts are not repairable and must be replaced if damaged:

- Center Spar
- Wing Spar
- Main Gear Leg (If damage exceeds allowable limit specified in Note below.)
- Nose Strut
- Nose Gear Torque Tubes

NOTE: Minor surfaces delaminations are acceptable providing they do not extend more than one ply into the surface of the strut. Corner delaminations (slivers) are acceptable if they are smaller than 1/16 x 1/16 inch in size throughout their length. To correct these minor damages see Approved Repairs, Paragraph 14.

12. Rivet Substitution

Rivets of higher strength than those called out may be used on any structural repair.

13. Primary Structures

The following portions of the aircraft are primary structures.

A. Fuselage

- (1) Engine Mount
- (2) Engine Mount Extrusions
- (3) Lower Fuselage Honeycomb Corners (4 inches of floor and 4 inches of side panels)
- (4) Upper 4 inches of Fuselage Honeycomb Side Panels
- (5) Center Spar
- (6) Center Spar Attach Collars
- (7) Nose Gear Assembly
- (8) Main Gear Assembly
- (9) Aft Fuselage Waterline 49.00 Stiffener Flanges
- (10) Aft Fuselage Lower Corner Flanges
- (11) Aft Fuselage Bulkhead (Stabilizer Spar Attach)
- (12) Horizontal and Vertical Stabilizer Forward Attach Fuselage Bulkheads
- (13) Forward Turtleback Bulkhead
- (14) Aft Fuselage/Cabin Honeycomb Side and Bottom Bond Joints

B. Control System

- (1) All Components

C. Wing

- (1) Wing Main Spar
- (2) Wing Main Spar Doublers

D. Empennage

- (1) Stabilizer Rear Spars
- (2) Stabilizer Front Spars

E. Control Surfaces

- (1) Support Brackets
- (2) Balance Weight Supports
- (3) Torque Tubes

AIRFRAME STRUCTURAL REPAIR – APPROVED REPAIRS

1. Leading Edge Repair

Figure 801 illustrates a typical repair to be employed in patching skin on the leading edge. The repair should be made flush with the external surface of the leading edge skin and surface contour must be maintained.

Repair skin as follows:

- A. Trim out the damaged area in a rectangular pattern and deburr.
- B. Place repair doubler beneath wing skin as shown in Figure 801.

NOTE: Dimensions given in Figure 801 are typical for most repairs of the leading edge.

- C. Holding repair doubler in place, drill dimple holes (1/8 inch diameter) through wing skin, spacing holes 5/8 inch apart from center of hole to center of adjacent hole.

NOTE: This repair can be completed in the area of wing ribs by installing the doubler in two pieces, one on each side of the rig flange.

- D. Secure doubler to wing leading edge with 1/8 inch diameter countersunk Cherry rivets (CR162) or equivalent. If bucked rivets are used, exercise caution to prevent nearby bond damage.

NOTE: Filler should be of the same material and thickness as skin.

- E. Place filler flush with the doubler.
- F. Holding filler piece in place, drill dimple holes through filler, spacing holes 5/8 inch apart from center of hole to center of adjacent hole.
- G. Secure filler to doubler with rivets as specified in Step D.
- H. Use an epoxy filler as necessary and sand smooth.

2. Wing Rib Repair

Figure 802 illustrates typical wing rib repairs. If the wing ribs are extensively damaged, they should be replaced. Refer to Chapter 57.

Repair rib as follows:

NOTE: If rib damage consists of a crack, stop drill crack if crack does not extend to edge of part and add reinforcement plate to carry stress across damaged portion and stiffen the joints.

- A. If the area to be repaired is damaged extensively, trim out damaged area and deburr.

NOTE: Repair parts shall be 6061-T6 or equivalent.

- B. Hold doubler (.032 inch thick) in place against the damaged area on the rib structure. If extra support is needed, place a formed angle against the inside portion of the rib nested under the flange; and place a doubler on the opposite side of the rib against the damaged area.

NOTE: Dimensions given in Figure 802 are typical for most repairs of the wing rib.

- C. With repair parts held in place, drill 1/8 inch diameter holes through repair parts and rib structure, spacing holes 3/4 inch apart from center of hole to center of adjacent hole. Holes drilled at the ends of the formed angle should be placed 1/4 inch from the edge.

AA-5 SERIES
MAINTENANCE MANUAL

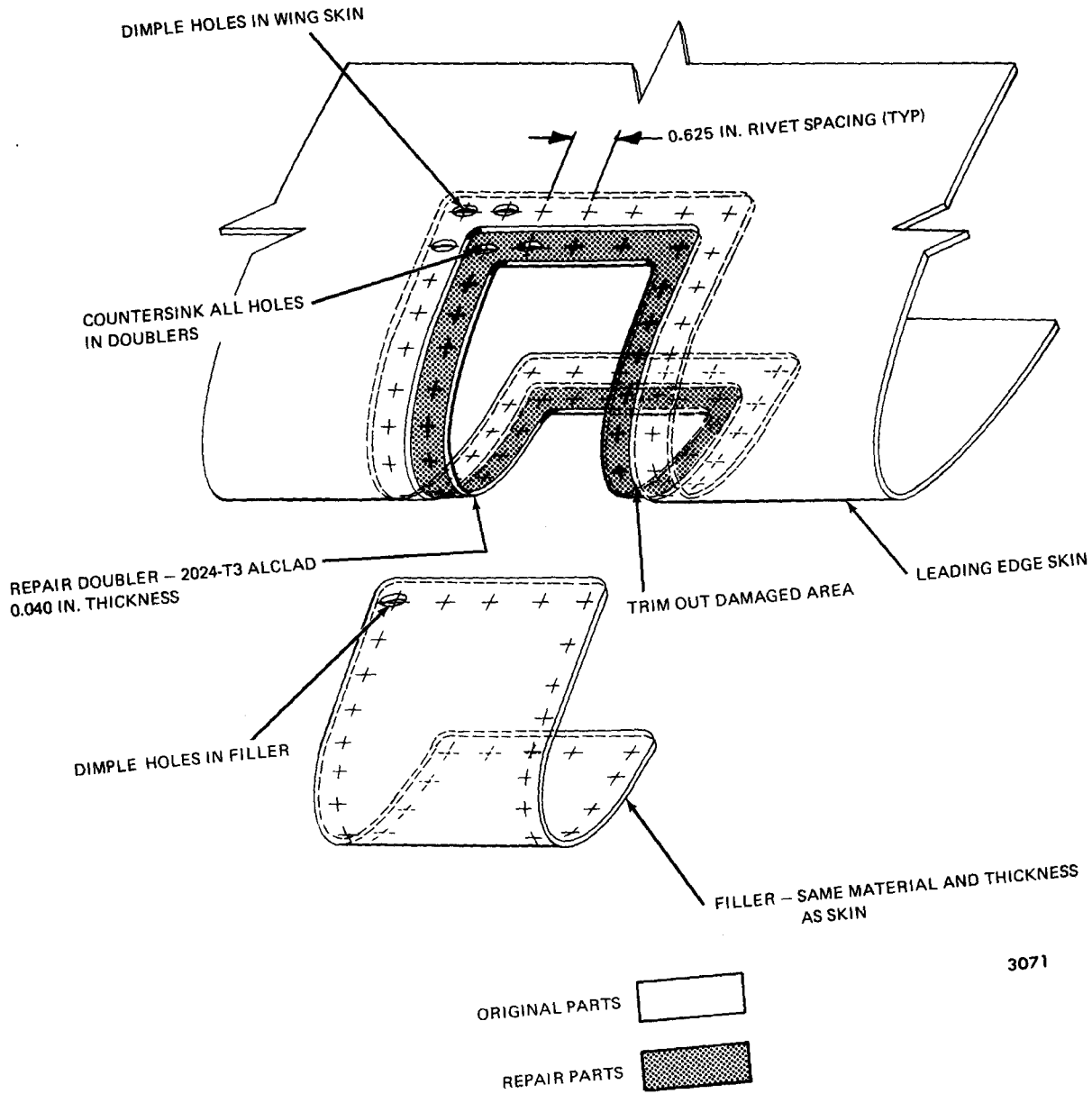

3071

Leading Edge Repair (Riveted)
Figure 801

AA-5 SERIES
 MAINTENANCE MANUAL

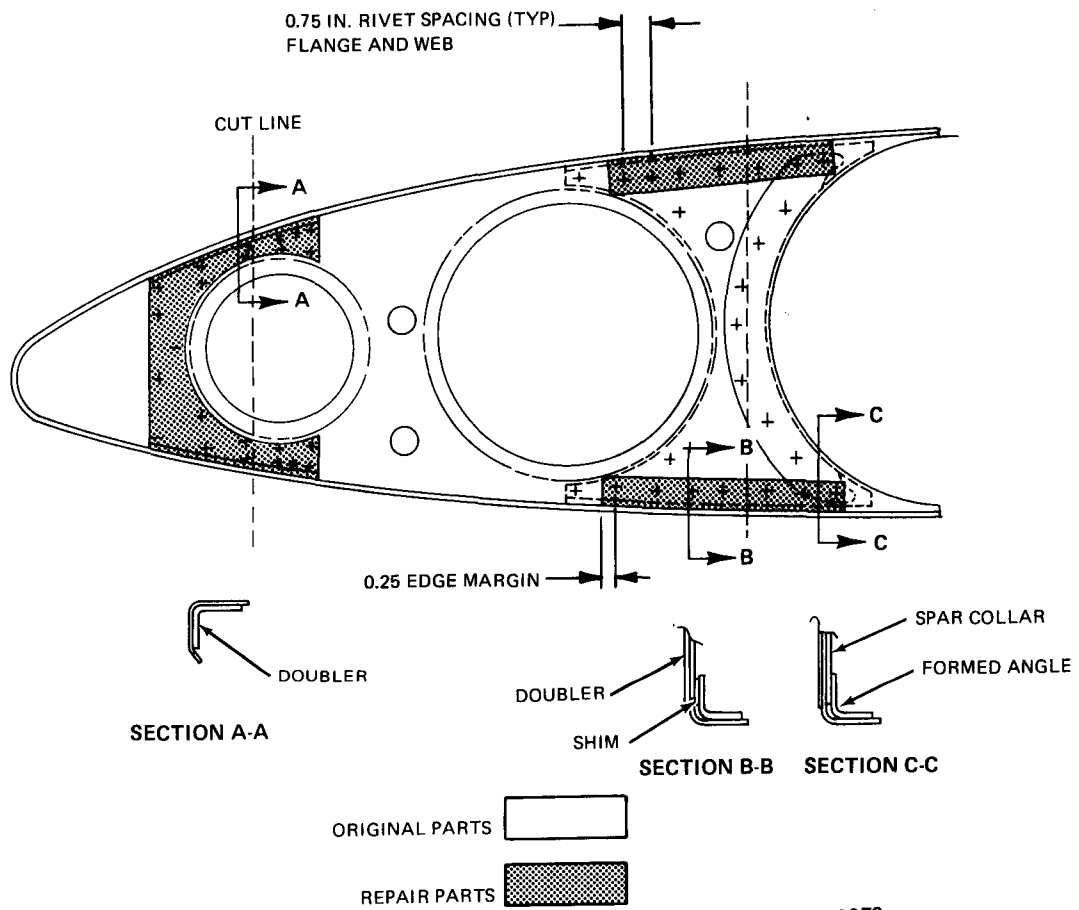

Wing Rib Repair (Riveted)
 Figure 802

- D. Install all rivets (1/8 inch diameter Cherry rivets CR162, CR163, or equivalent) with wet zinc chromate primer. If bucked rivets are used, exercise caution to prevent nearby bond damage.
- E. After the repair is completed, the repaired area should be coated with zinc chromate primer.

3. Honeycomb Repair, Partial Core Damage

Minor damage extending partially through the core of honeycomb panel and equal to or less than 1 inch diameter (Figure 803) can be repaired with an external doubler as follows:

- A. Trim out damaged area of face sheet in a circular pattern.
- B. Thoroughly clean the repair area with fine sandpaper and acetone.
- C. Coat all repair parts with zinc chromate primer.
- D. Seal the exposed honeycomb core with PR1436GB-2 Inhibited Sealant.
- E. Using Service Kit SK-102A, apply resin filler to area where damaged honeycomb core was removed.

NOTE: Refer to AC 43.13-1 for doubler and rivet pattern dimensions. Dimensions given in Figure 803 are typical repair for this type.

- F. Place 2024-T3 alclad aluminum doubler (0.40 inch thick) over repair area and drill out 1/8 inch diameter holes around circumference of doubler.
- G. Dip all rivets (1/8 inch diameter Cherry rivets, CR162, CR163, or equivalent) in PR1436GB-2 Inhibited Sealant and install to secure doubler to honeycomb panel.
- H. Fair external doubler periphery with epoxy filler to maintain a smooth surface.
- I. Coat repaired area with zinc chromate primer.

4. Honeycomb Repair, Extensive Core Damage

Damaged areas greater than 1 inch diameter or areas in which damage extends completely through the core require removal of the damaged area and installation of a honeycomb repair section. (See Figures 804, 805, and 806.)

- A. Patch repair using external and internal doublers. (See Figure 804.)

Repair honeycomb as follows:

- (1) Trim out damaged area in a circular pattern as shown in Figure 804 and deburr.
- (2) Coat all repair parts with zinc chromate primer.
- (3) Seal all exposed honeycomb core areas on the repair section and the panel section with PR1436GB-2 Inhibited Sealant.
- (4) Place internal and external doublers (2024-T3 alclad aluminum, 0.040 inch thick) over repair area.

NOTE: Refer to AC 43.13-1 for hole diameter limitations and corresponding rivet patterns.

- (5) Dip all rivets (1/8 inch diameter Cherry rivets, CR162, CR163, or equivalent) in PR1436GB-2 Inhibited Sealant and install through the doubler and repair section (both sides) such that maximum distance between any two rivets is 1.5 inch.
- (6) Fair external doubler periphery with epoxy filler to maintain a smooth surface.

AA-5 SERIES
MAINTENANCE MANUAL

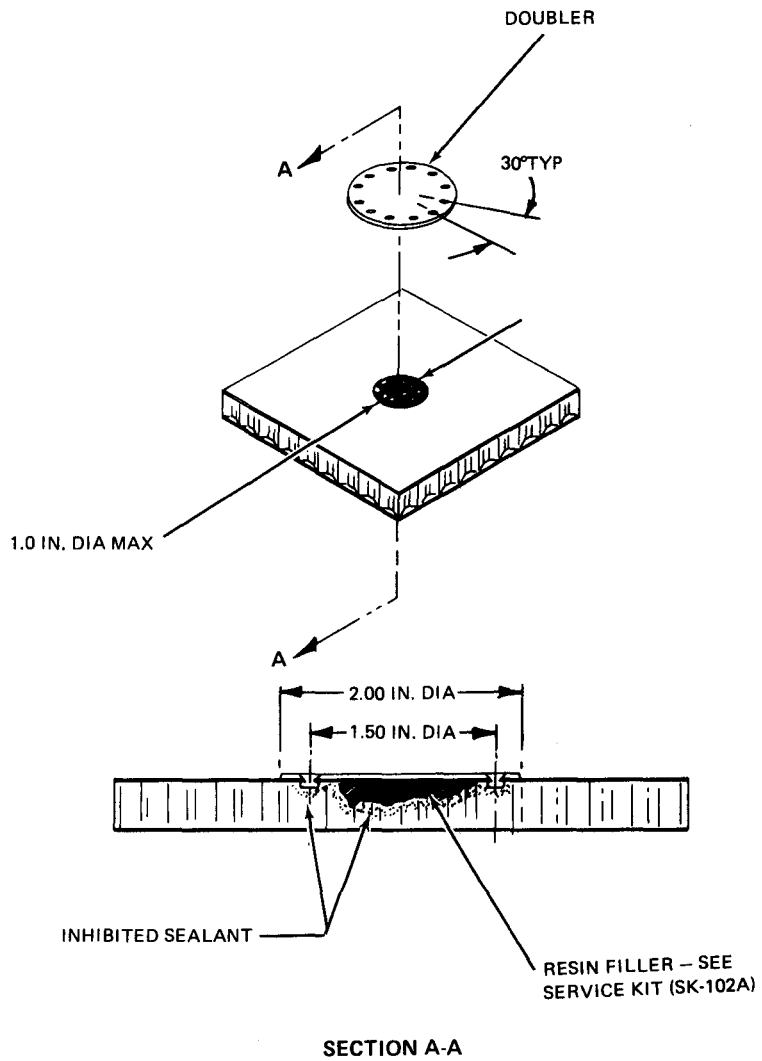

3075

Honeycomb Repair, Partial Core Damage
Figure 803

AA-5 SERIES
MAINTENANCE MANUAL

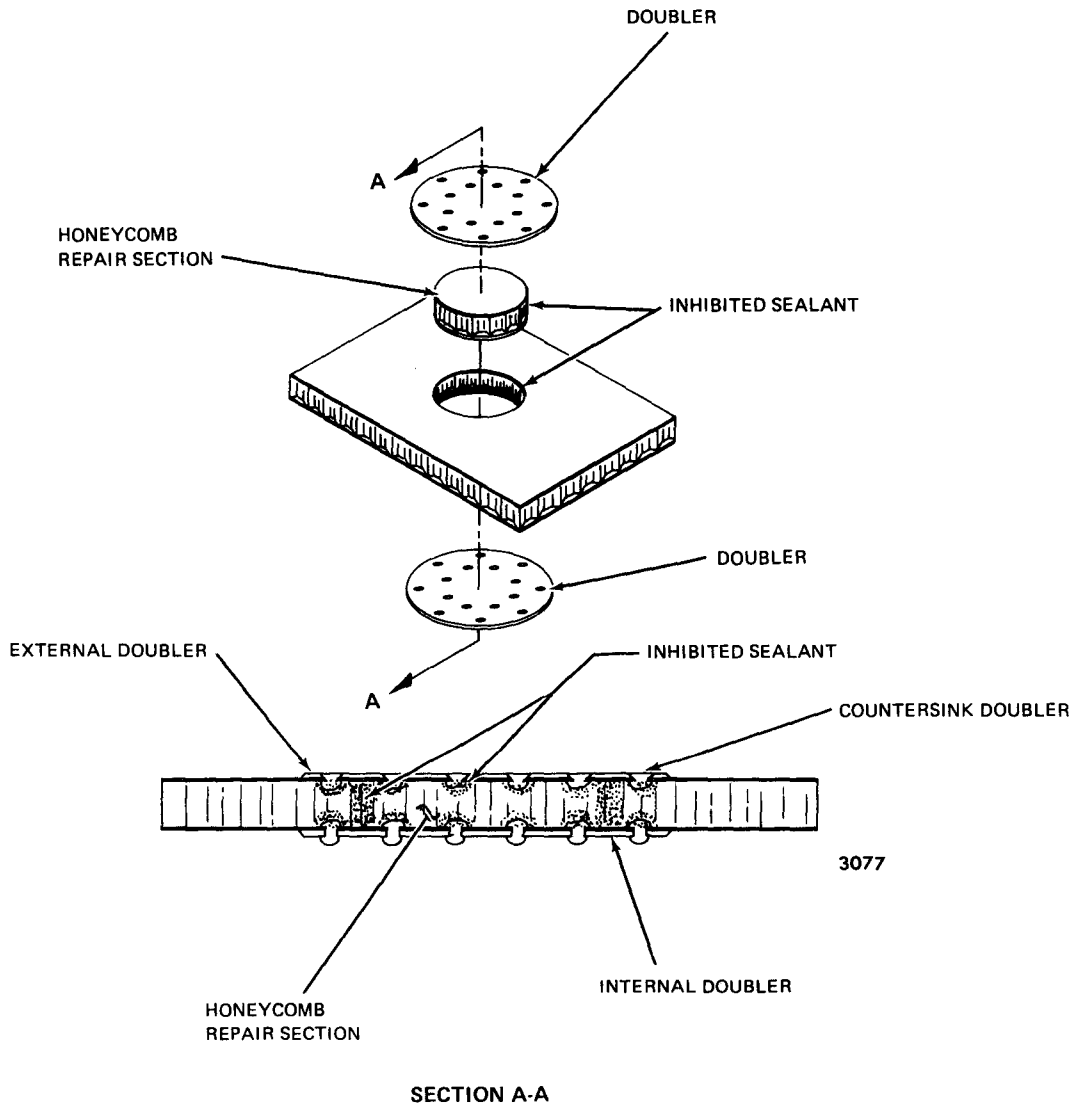

Honeycomb Patch Repair, External and Internal Doublers
Figure 804

AA-5 SERIES
MAINTENANCE MANUAL

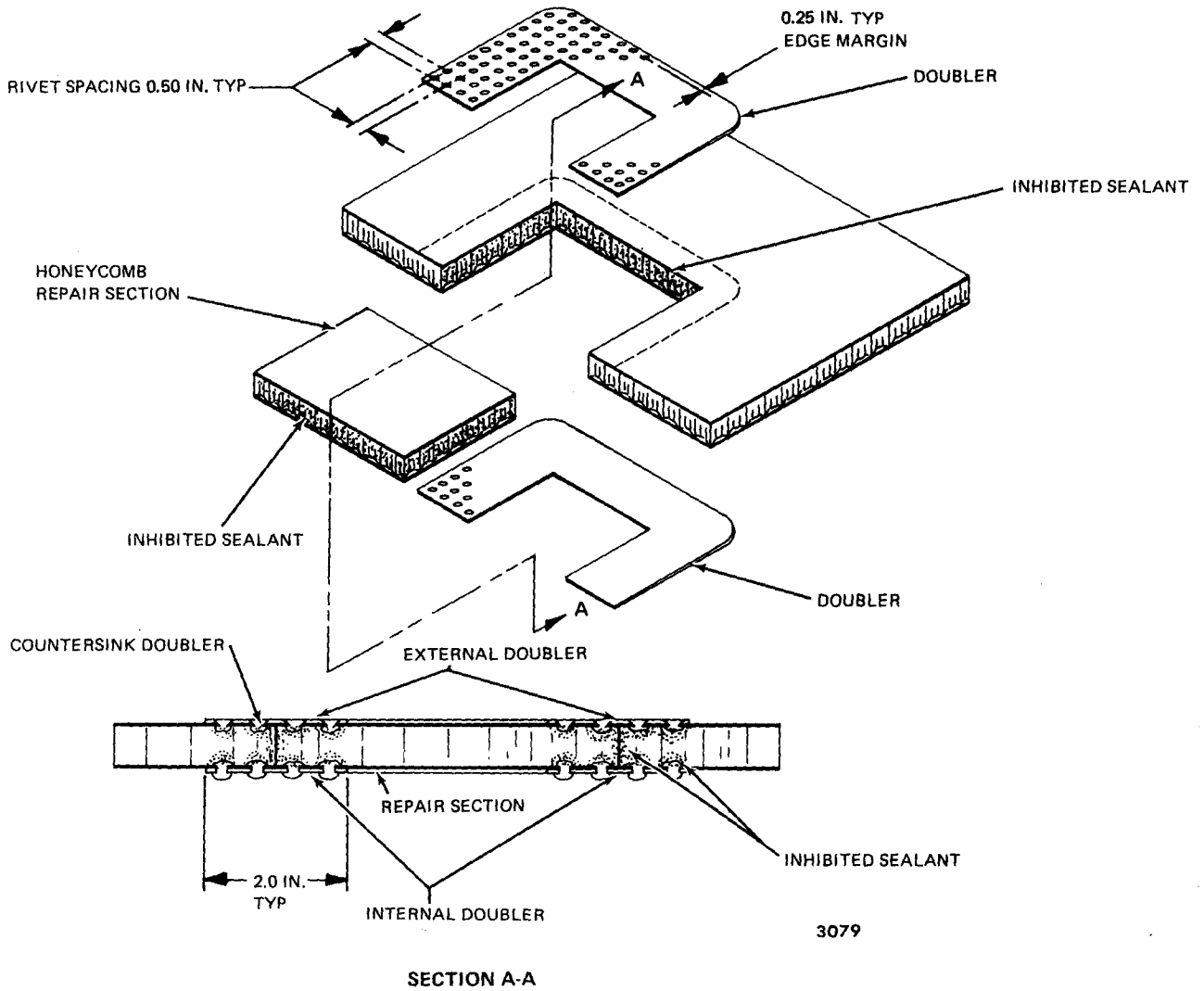

Honeycomb Repair using Spliced-In Panel Section
Figure 805

**AA-5 SERIES
MAINTENANCE MANUAL**

(7) Coat repair area with zinc chromate primer.

B. Splicing in New Panel Section (See Figure 805.)

This repair is satisfactory for most honeycomb repairs which require new panel sections to be spliced into existing structure. Repair honeycomb as follows:

- (1) Trim out damaged area in a rectangular pattern as shown in Figure 805 and deburr.
- (2) Coat all repair parts with zinc chromate primer.
- (3) Seal all exposed honeycomb core areas with PR1436GB-2 Inhibited Sealant.
- (4) Place internal and external doublers (2024-T3 alclad aluminum) over repair area. The external doubler shall be 0.040 inch thick, and the internal doubler shall be 0.032 inch thick.

NOTE: Dimensions given in Figure 805 are typical for most honeycomb repairs using external doublers.

- (5) Dip all rivets (1/8 inch diameter Cherry rivets, CR162, CR163, or equivalent) in PR1436GB-2 Inhibited Sealant and install through the doubler and repair section (both sides).
- (6) Fair external doubler periphery with epoxy filler to maintain a smooth surface.
- (7) Coat repaired area with zinc chromate primer.

5. Honeycomb Repair, Forward Fuselage Section

Repair in the area of the forward fuselage section of the aircraft can be accomplished using (a) external doublers as shown in Figure 804, (b) rectangular sections of honeycomb the length of the repair splice similar to Section AA of Figure 805, or (c) the sheet metal pan and doubler method as described below.

The external doublers are recommended for repair splices in the firewall and floor honeycomb panels. This allows the honeycomb panels to be butted enhancing ease of repair. The decision on whether to use an external or flush repair on the fuselage side panel is a matter of preference. When using the sheet metal pan and doubler (Figure 806) repair honeycomb as follows:

CAUTION: TO PREVENT DISTORTION, CAREFULLY SUPPORT OUTER FACE SHEETS OF HONEYCOMB PANELS WHILE REMOVING CORE MATERIAL.

- A. Remove damaged core material from the internal surface side of panel.
- B. Coat all parts with zinc chromate primer.
- C. Seal all exposed honeycomb core areas with PR1436GB-2 Inhibited Sealant.

NOTE: Obtain preformed pan sections through your authorized Gulfstream American Dealer or Distributor.

- D. Countersink pan and dimple honeycomb face sheets.
- E. Provide fit for pan (0.063 inch 2024-T3 alclad aluminum or equivalent) by crushing internal face sheet and core edges.
- F. After fitting pan into panel, install rivets to secure external surface to pan bottom (rivet spacing in Figure 806 is typical).

NOTE: Dimensions given in Figure 806 are typical for most honeycomb repairs of this type.

- G. Place doubler (0.063 inch 2024-T3 alclad aluminum or equivalent) over pan.

AA-5 SERIES
MAINTENANCE MANUAL

- H. Dip all rivets (1/8 inch diameter Cherry rivets, CR162, CR163, or equivalent) in PR1436GB-2 Inhibited Sealant.
- I. Install rivets along outer edge of pan, penetrating doubler, pan and internal surface of panel (rivet spacing in Figure 806 typical).
- J. Coat the repaired area with zinc chromate primer.

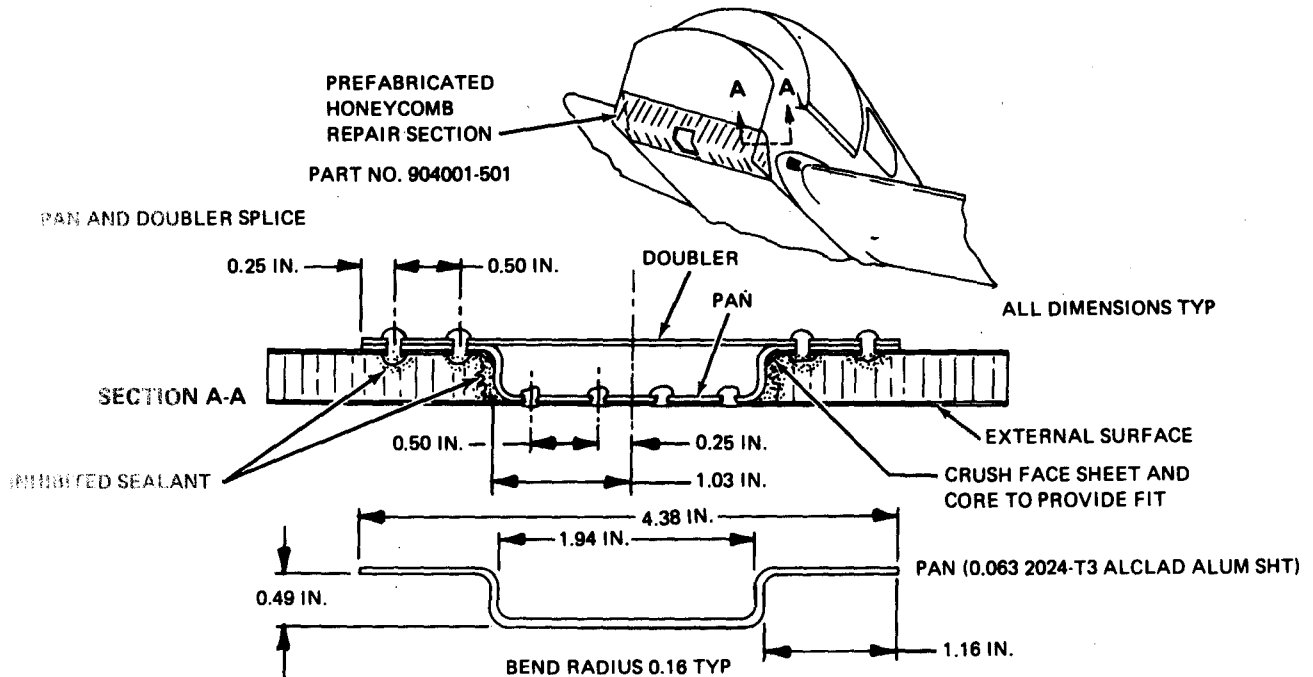

Honeycomb Repair — Forward Fuselage Section — (Flush Riveted)
Figure 806

Bonding Strap Angle Splice

In order to maintain the continuity of angles from an original panel to a repair panel, angles must be riveted over the bonding strap angles across the splice. (See Figure 807.)

Repair honeycomb panel using the bonding strap angle splice as follows:

- A. Remove damaged honeycomb panel section.
- B. Coat all parts with zinc chromate primer.
- C. Seal all exposed honeycomb core areas with PR1436GB-2 Inhibited Sealant.
- D. Install honeycomb repair section at fuselage corner junction with bonding strap angle.
- E. Place splice angle (2024-T3 alclad aluminum) over the bonding strap angle and across the splice. (Where countersunk rivets are to be installed, angle thickness shall be 0.040 inch. Otherwise, 0.032 inch thick material is satisfactory.)

NOTE: The length of the external splice angle can be increased as required for appearance purposes. If splice angle length is increased, rivet spacing may be increased proportionately up to 1.0 inch maximum.

**AA-5 SERIES
MAINTENANCE MANUAL**

- F. Dip all rivets (1/8 in. diameter Cherry rivets, CR162, CR163 or equivalent) in PR1436GB-2 Inhibited Sealant.
- G. Install a minimum of 8 rivets on each side of splice (rivet spacing as shown in Figure 807 typical).
- H. Coat the repaired area with zinc chromate primer.

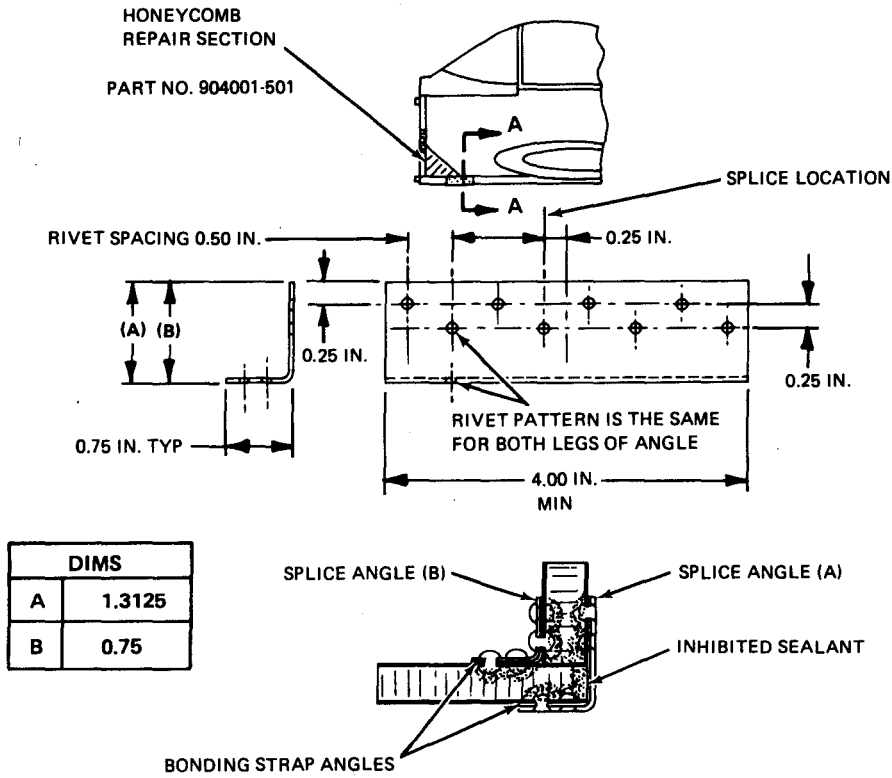

SECTION A-A

3084

Bonding Strap Angle Splice -- (Riveted)
Figure 807

**AA-5 SERIES
MAINTENANCE MANUAL**

7. Honeycomb Repair, Lower Engine Mount Area (Model AA-5)

Repair damaged honeycomb in the area adjacent to the two lower engine mount extrusions (Figure 808) on the Model AA-5 as follows:

- A. Remove damaged honeycomb area and engine.
- B. Using fine grain sandpaper, clean away all remaining adhesive before riveting in repair sections. Coat any remaining exposed bondlines with PR1436GB-2 Inhibited Sealant.
- C. Coat all parts with zinc chromate primer.
- D. Seal all exposed honeycomb core areas with PR1436GB-2 Inhibited Sealant.

NOTE: Numbers in parentheses denote call-outs in Figure 808.

- E. Using 10 MS426AD4-14 rivets dipped in PR1436GB-2 Inhibited Sealant rivet 2024-T3 alclad spacer (3) and 2024-T3 alclad splice (4) to bottom block (2). (See Section B-B, Figure 808)
- F. Fit bottom block with engine mount extrusion into position in repair area, and place 2024-T3 alclad spacer (5) to fit under splice installed in Step E above.
- G. Using 27 CR2249-4-3 rivets dipped in PR1436GB-2 Inhibited Sealant, rivet through splice (6), spacer (5) and bottom honeycomb panel. (See Section D-D, Figure 808)
- H. Using 34 CR2248-4-2 rivets dipped in PR1436GB-2 Inhibited Sealant rivet through splice (4), spacer (3), and underneath side of bottom honeycomb panel. (See Section B-B, Figure 808)
- I. Slide side block (1) into place between side honeycomb panel and bottom block.
- J. Slide reinforcement panel (7) between side block and new engine mount extrusion.
- K. Using 48 CR2249-4-2 rivets dipped in PR1436GB-2 Inhibited Sealant rivet reinforcement panel (7) to side honeycomb panel. (See Section C-C, Figure 808)
- L. Using 18 MS426AD4-12 rivets dipped in PR1436GB-2 Inhibited Sealant rivet through engine mount extrusion, reinforcement panel (7), and side block (1). (See Section C-C, Figure 808)
- M. Fill over rivet heads on exterior areas with epoxy filler and smooth before applying primer.
- N. Coat repaired area with zinc chromate primer prior to application of exterior finish paint.

8. Honeycomb Repair, Upper Engine Mount Area (Model AA-5)

Repair damaged honeycomb in the area adjacent to the two upper engine mount extrusions (Figure 809) on the Model AA-5 as follows:

- A. Trim out damaged honeycomb area with engine mount extrusion.
- B. Using fine grain sand paper, clean away all remaining adhesive before riveting in repair sections.
- C. Coat any remaining exposed bondlines with PR1436GB-2 Inhibited Sealant.
- D. Coat all parts with zinc chromate primer.
- E. Seal all exposed honeycomb core areas with PR1436GB-2 Inhibited Sealant.

NOTE: Numbers in parentheses denote call-outs in Figure 809.

AA-5 SERIES
MAINTENANCE MANUAL

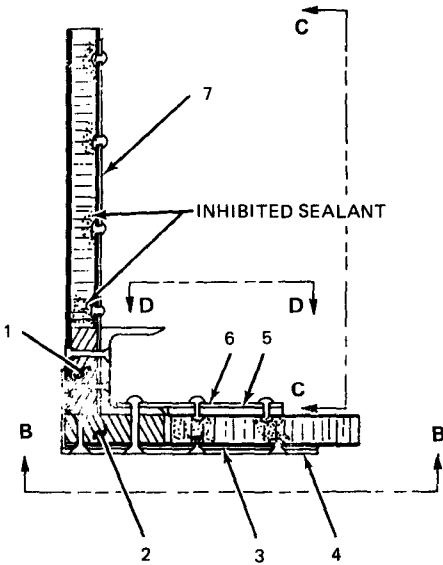
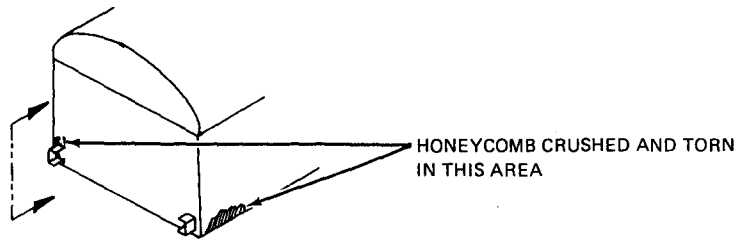

| ITEM | DESCRIPTION | MATERIAL |
|------|--|--------------------|
| 1. | Block .484 x 1.5 x 9.6 | 2014-T6 or 2024-T3 |
| 2. | Block .484 x 1.7 x 9.6 | 2014-T6 or 2024-T3 |
| 3. | Spacer t = .025, trim to fit under item 4. | 2024-T3 Alclad |
| 4. | Splice See Section B-B | 2024-T3 Alclad |
| 5. | Spacer t = .090, trim to fit under item 6. | 2024-T3 Alclad |
| 6. | Splice See Section D-D | 2024-T3 Alclad |
| 7. | Reinforcement t = .080 See Section C-C | 2024-T3 Alclad |

View B-B, C-C, & D-D on following page.

3087

NOTE: Nose gear torque tube not shown.

SECTION A-A Locking Aft (Firewall Removed)

Honeycomb Repair, Lower Engine Mount Area (Sheet 1 of 2)
Figure 808

AA-5 SERIES
MAINTENANCE MANUAL

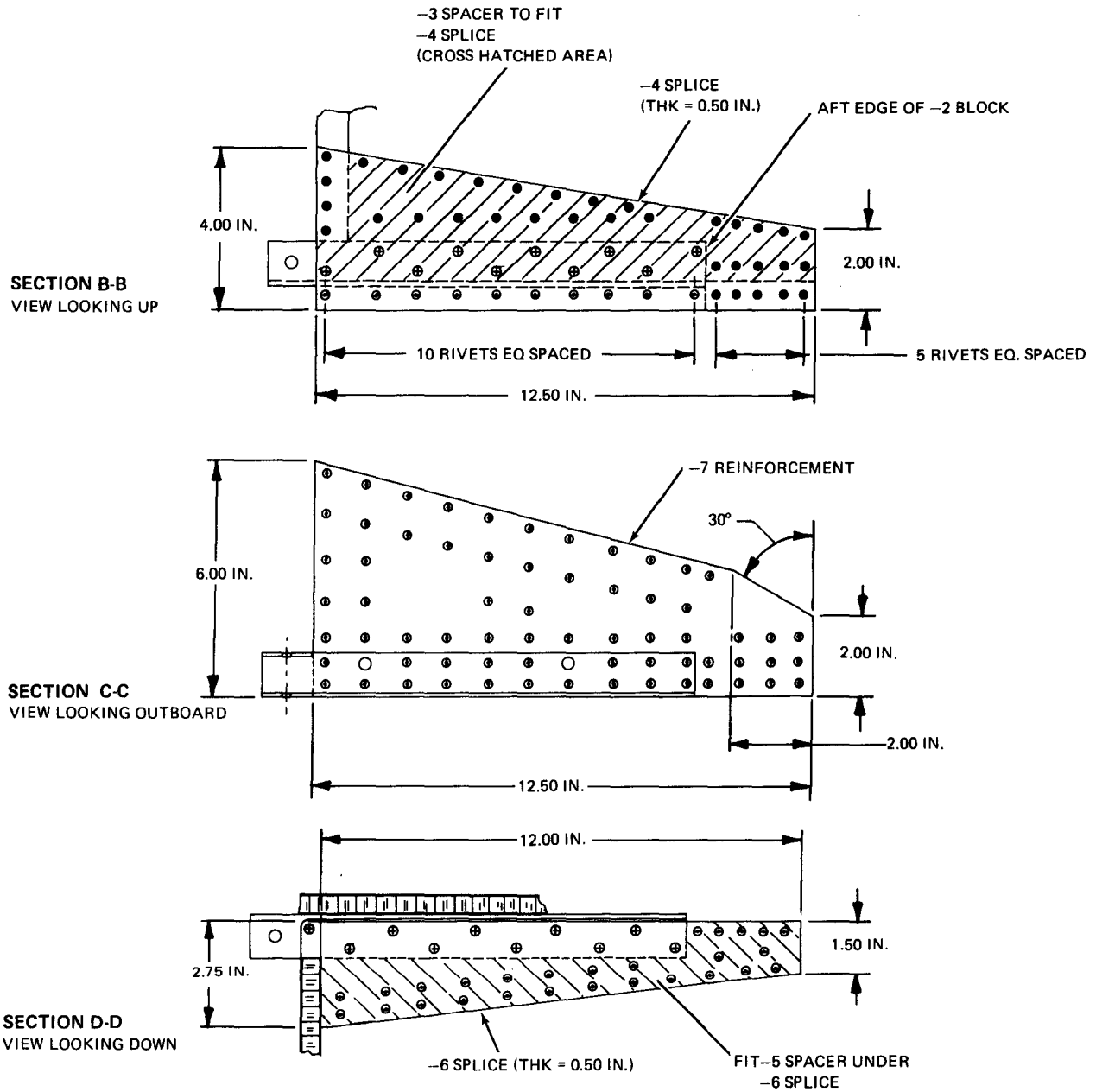

3093

- ⊙ MS426AD4-14 Double Countersunk as shown, Section A-A
- CR2248-4-2 Located as shown 35 req'd.
- ⊕ MS426AD4-16 10 req'd.
- ⊖ CR2249-4-3 27 req'd.
- ⊙ MS426AD4-12 18 req'd.
- ⊙ CR2249-4-2 48 req'd.

Honeycomb Repair, Lower Engine Mount Area (Sheet 2 of 2)
Figure 808

**AA-5 SERIES
MAINTENANCE MANUAL**

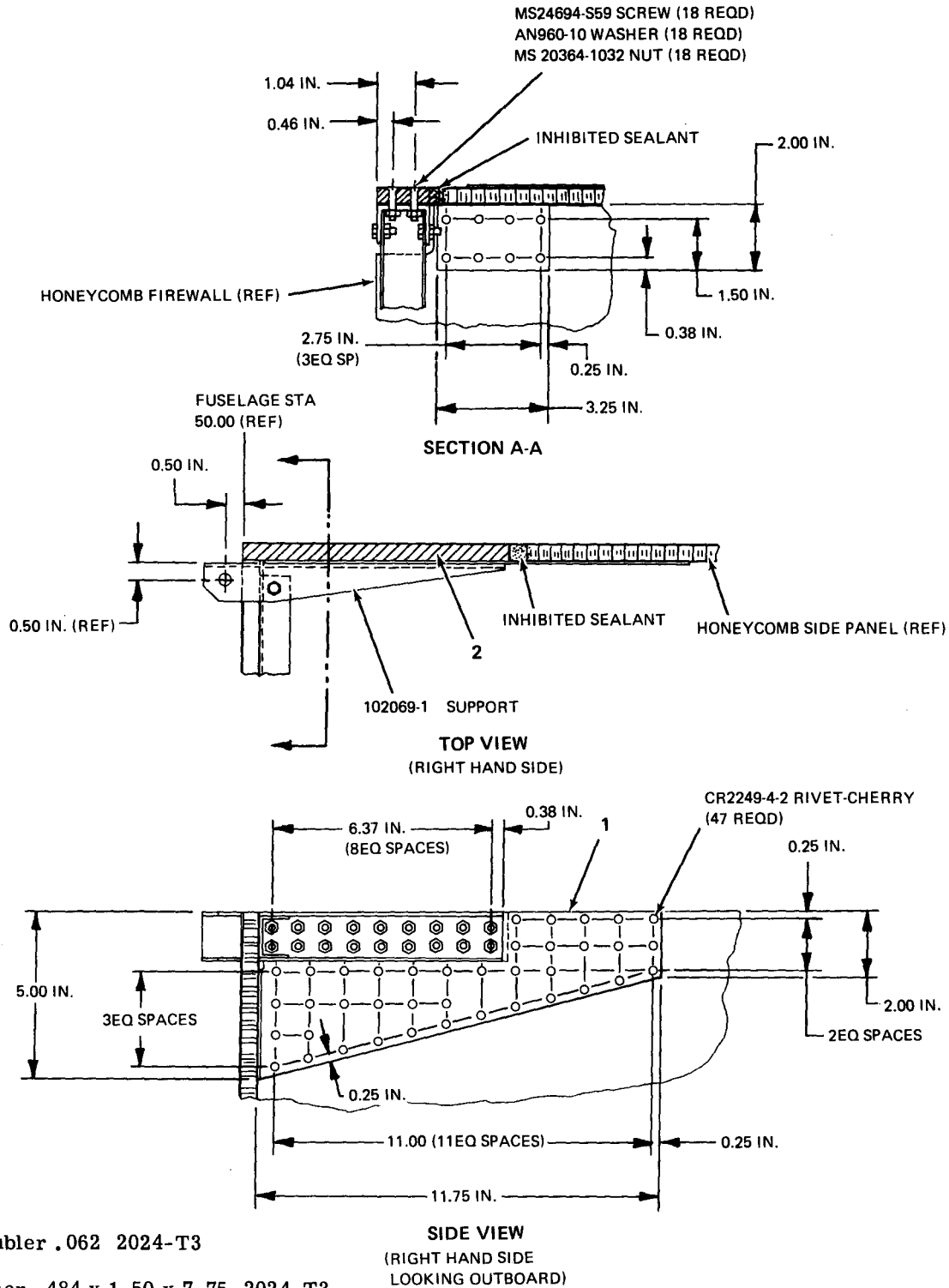

3094

ITEM

1. Doubler .062 2024-T3
2. Filler .484 x 1.50 x 7.75 2024-T3
(Alternate-Use .125 thick 2024-T3 laminated)

**Honeycomb Repair, Upper Engine Mount Area
Figure 809**

AA-5 SERIES
MAINTENANCE MANUAL

- F. Place doubler repair section (1) into place flush against honeycomb side panel and honeycomb front panel (Fuselage Station 50.0).
- G. Using 47 CR2249-4-2 Cherry rivets dipped in PR1436GB-2 Inhibited Sealant, rivet doubler to honeycomb side panel and honeycomb front panel.
- H. Place new filler section (2) into repair area, flush against doubler (1).
- I. Install new engine mount extrusion to doubler and filler sections with 18 MS24694-S59 screws, AN960-10 washers, and MS20364-1032 nuts.
- J. Drill new engine mount holes in extrusion.
- K. Fill over rivet heads and bolt heads on exterior areas with epoxy filler and smooth before applying primer.
- L. Coat repaired area with zinc chromate primer prior to application of exterior finish paint.

9. Honeycomb Panel Replacement (Station 50)

Replace the forward fuselage (Station 50) honeycomb panel (Figure 810) as follows:

- A. Remove damaged forward fuselage honeycomb panel without removing existing 102293-3 and 102293-5 angles.
- B. Using fine grain sand paper, clean away all remaining adhesive before riveting in repair sections. Coat any remaining exposed bondlines with PR1436GB-2 Inhibited Sealant.
- C. Coat all parts with zinc chromate primer.
- D. Seal all exposed honeycomb core areas with PR1436GB-2 Inhibited Sealant.
- E. Place new honeycomb panel into position flush against existing angles, 102293-3 and 102293-5. Rivet panel to angles using CR2249-4-1 rivets dipped in PR1436GB-2 Inhibited Sealant.

NOTE: Numbers in parentheses denote call-outs in Figure 810.

- F. Using CR2248-4-1 rivets dipped in PR1436GB-2 Inhibited Sealant, rivet side angles (1) into place at corner junction of forward fuselage.
- G. Using CR2248-4-1 rivets dipped in PR1436GB-2 Inhibited Sealant rivet bottom angle (2) into place at bottom edge of forward fuselage.
- H. Fill over exterior rivets with epoxy filler and smooth before applying primer.
- I. Coat repaired area with zinc chromate primer prior to application of exterior finish paint.

10. Upper Forward Fuselage Assembly Replacement

Replace the entire upper forward fuselage assembly (Figure 811) as follows:

- A. Remove windshield. (See Chapter 56.)
- B. Scrape the bond at the aft end of the forward fuselage assembly near the canopy.
- C. With pliers, peel assembly from fuselage structure.
- D. Remove damaged upper forward fuselage assembly.
- E. Using fine grain sand paper, clean away all remaining adhesive before riveting new assembly in place.

AA-5 SERIES
MAINTENANCE MANUAL

ITEM

1. ANGLE 1.00 IN x 1.50 IN., Make from 2024-T3 Alclad
THK = 0.040 IN., LTH = 21.77 IN.
2. ANGLE 1.00 IN. x 1.50 IN. Make from 2024-T3 Alclad
THK = 0.040 IN., LTH = 17.80 IN.

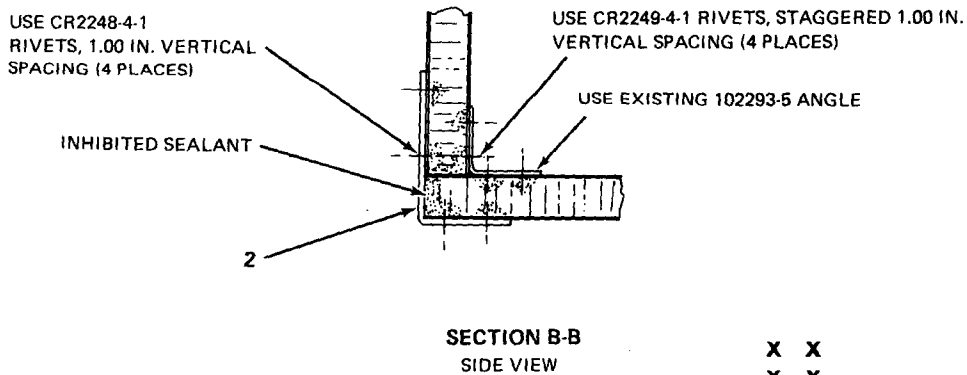
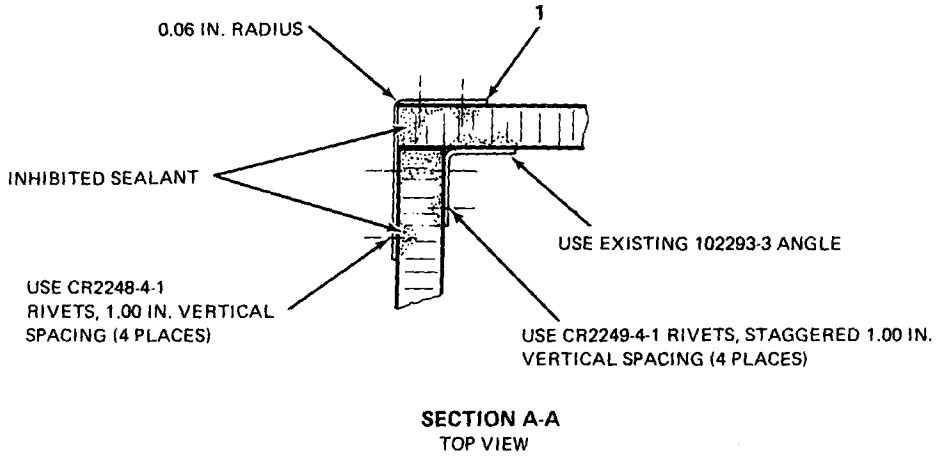
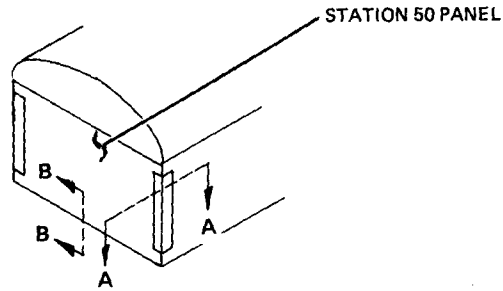

X X
X X
VERTICAL

X
X
STAGGERED
VERTICAL

3095

Honeycomb Panel Replacement (Station 50)
Figure 810

AA-5 SERIES
MAINTENANCE MANUAL

UPPER FORWARD FUSELAGE ASSEMBLY
PART NO. 5102295-501

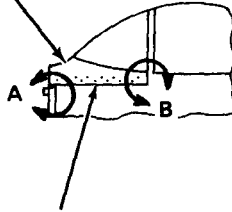

1601-0410 RIVET - AVEX
(20 REQD)

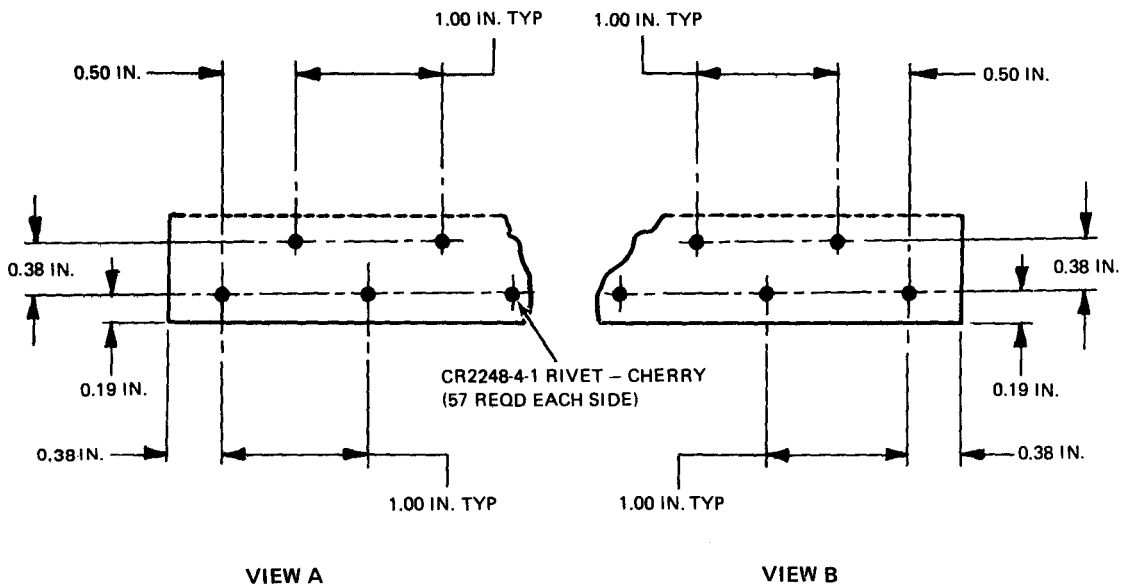

3096

Upper Forward Fuselage Assembly Replacement
Figure 811

- F. Coat all joints with PR1436GB-2 Inhibited Sealant.
- G. Align upper forward fuselage assembly with honeycomb panel on each side of fuselage according to dimensions given in Figure 811.

NOTE: Rivet spacing dimensions given below are typical for repairs of the upper forward fuselage assembly.

- H. Using CR2248-1 Cherry rivets dipped in PR1436GB-2 Inhibited Sealant, rivet upper forward fuselage assembly to honeycomb panel on each side of fuselage (57 rivets required per side).
- I. Using 20 1601-0410 Avex rivets dipped in PR1436GB-2 Inhibited Sealant, rivet upper forward fuselage assembly to firewall arch.
- J. Fill over exterior rivets with epoxy filler and smooth before applying primer.
- K. Coat repaired area with zinc chromate primer prior to application of exterior finish paint.

11. Aft Fuselage Assembly Replacement

Replace the entire aft fuselage assembly (Figure 812) as follows:

- A. Remove forward and aft side panel interiors. (See Chapter 25)
- B. Remove canopy. (See Chapter 52)
- C. Remove canopy rail (Figure 813) as follows:
 - (1) Remove bolt attaching canopy rail to forward fuselage and upper aft fuselage bulkhead.
 - (2) Drill out rivets attaching canopy rail to forward fuselage.
 - (3) Drill out rivets attaching rail to upper aft fuselage skin.
- D. Remove rear seat. (See Chapter 25.)
- E. Disconnect flap actuator motor from motor bracket.
- F. Disconnect all rigging cables (See Chapter 27), electrical wiring, and vacuum system tubing at rear seat section of fuselage.
- G. Remove vertical and horizontal stabilizers if existing stabilizers are to be used on new aft fuselage section. (See Chapter 55)
- H. Drill out rivets from two side braces connecting the two bulkhead assemblies at rear seat section of fuselage.
- I. Remove wings and wing roots. (See Chapter 57)
- J. Remove damaged aft fuselage station 128 (See Figure 814) as follows:
 - (1) On each side of fuselage, remove two 3/16 in. diameter bolts (just below W. L. 49) attaching flange of aft fuselage to aft end of forward fuselage side honeycomb panel.
 - (2) Remove remaining screw attaching upper aft fuselage bulkhead to forward fuselage.
 - (3) Drill out rivets to remove gussets from bottom edges of fuselage (W. L. 25, F. S. 128).
 - (4) On inside of fuselage forward of F. S. 128, remove rivets from reinforcement which secures aft fuselage to top edge of forward fuselage.
 - (5) Pry flange of aft fuselage section from forward fuselage section and with a pair of pliers, peel skin off to remove.

AA-5 SERIES
MAINTENANCE MANUAL

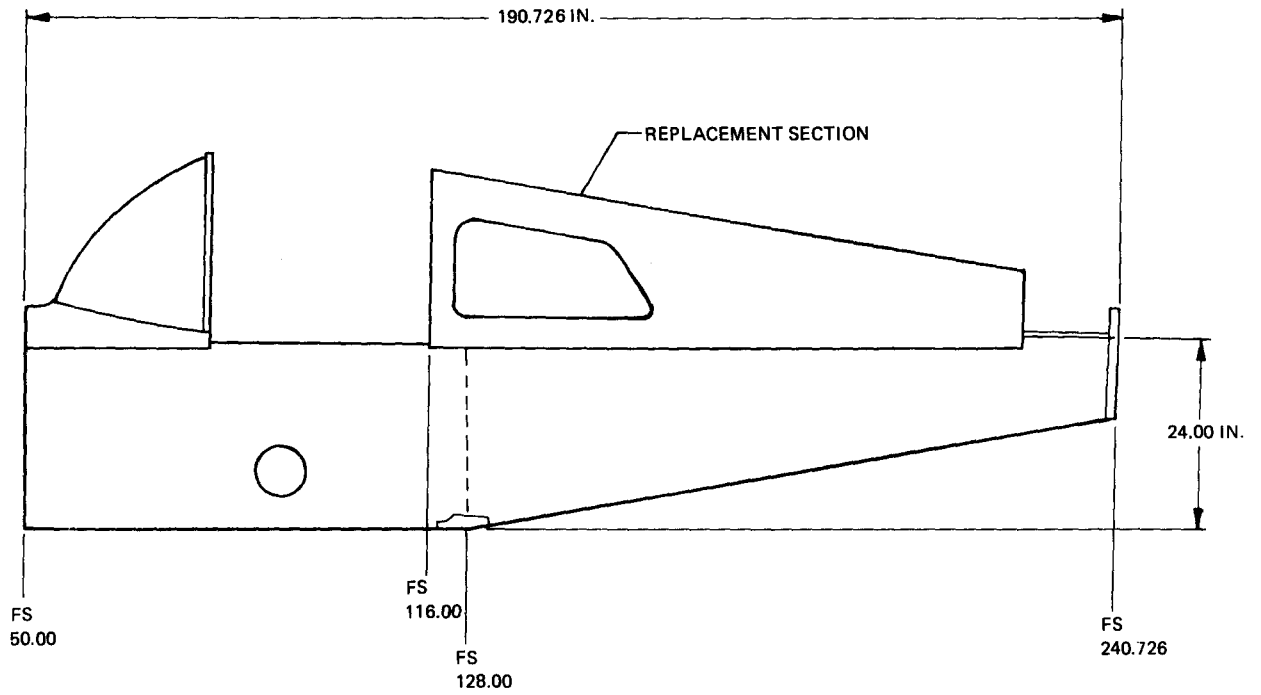

3475

Overall Fuselage Dimensions
Figure 812

**AA-5 SERIES
MAINTENANCE MANUAL**

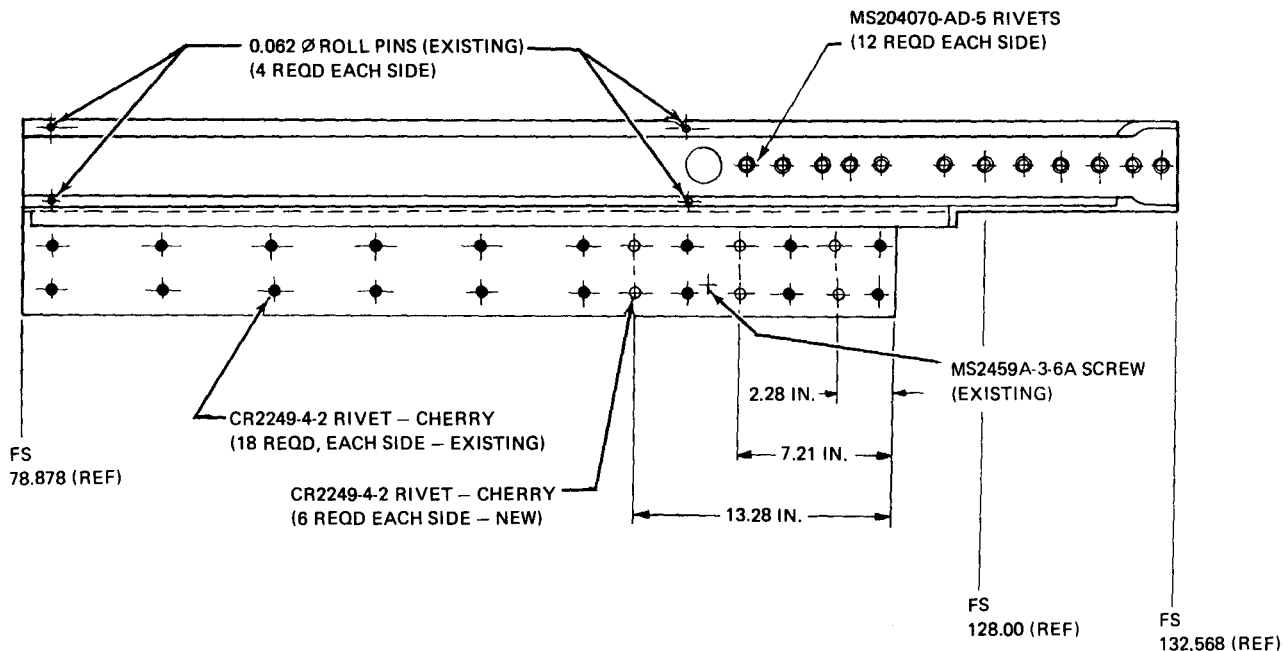

- ⊕ NEW HOLES - CR2249-4-2 RIVETS
- EXISTING HOLES - CR2249-4-2 RIVETS
- ⊗ EXISTING HOLES - MS20470-AD-5 RIVETS
- ⊙ EXISTING HOLES - 0.062 DIA ROLL PINS

3416

Installation of Track Assembly - Canopy Outer
Figure 813

AA-5 SERIES
MAINTENANCE MANUAL

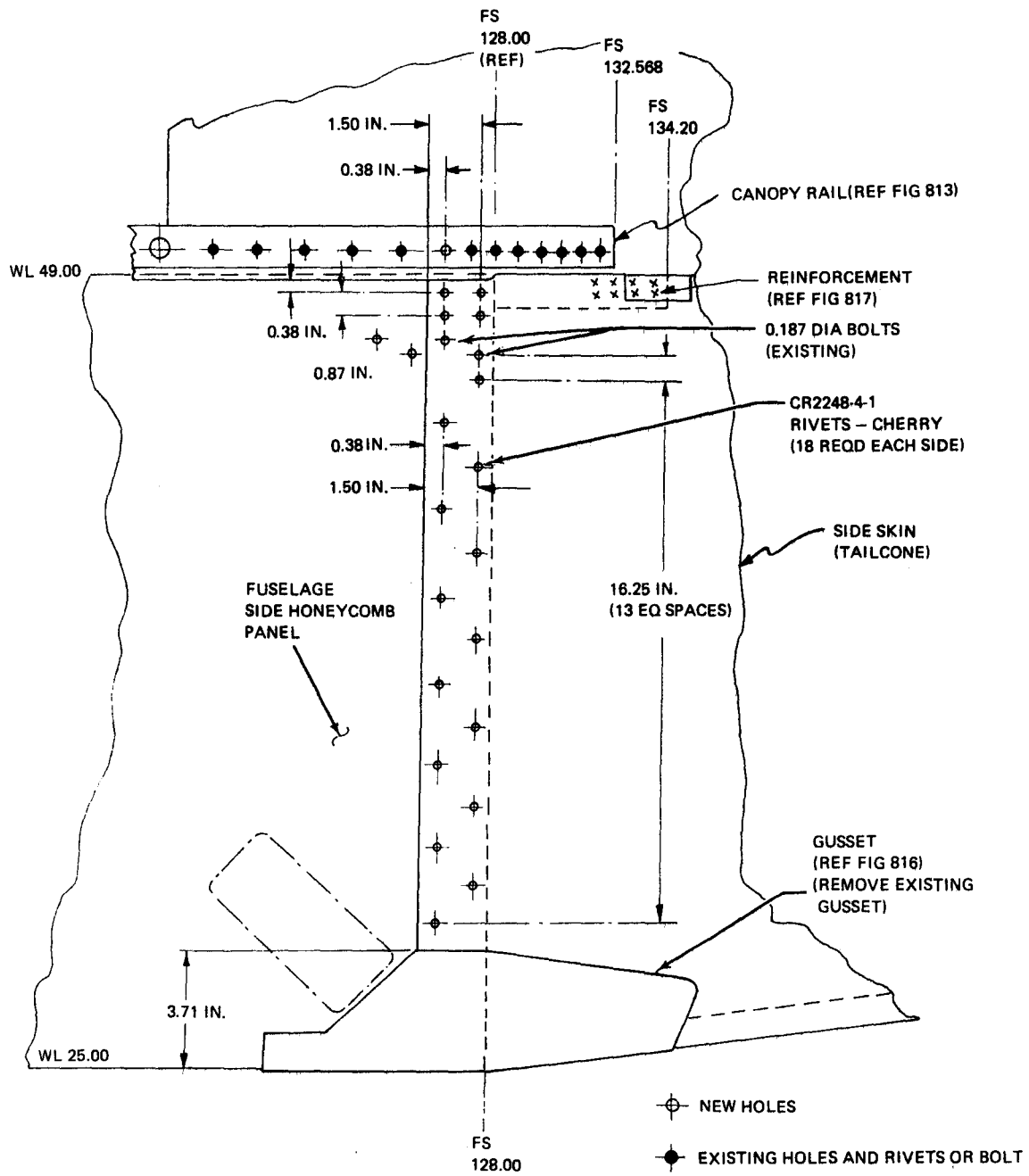

3417

Fuselage Side Attachment Details
Figure 814

**AA-5 SERIES
MAINTENANCE MANUAL**

- K. Using fine grain sand paper, clean away all remaining adhesive before riveting new assembly in place.
- L. Seal any exposed honeycomb core with PR1436GB-2 Inhibited Sealant.
- M. Align aft fuselage assembly with forward fuselage assembly according to dimensions given in Figures 814 and 815.
- NOTE: Rivet spacing dimensions given in Figure 814 and 815 are typical for typical for repairs of the aft fuselage assembly.
- N. Install bolt attaching upper aft fuselage bulkhead to forward fuselage.
- O. On each side of fuselage, install two 3/16 in. diameter bolts (just below W.L. 49) attaching flange of aft fuselage to aft end of forward fuselage side honeycomb panel.
- P. Using CR2248-4-1 Cherry rivets dipped in PR1436GB-2 Inhibited Sealant, rivet flanges of aft fuselage section to forward fuselage side honeycomb panel. (Eighteen (18) rivets required for each side of fuselage. (See Figure 814)
- Q. Using thirty-one (31) CR2249-4-1 Cherry rivets dipped in PR1436GB-2 Inhibited Sealant, rivet bottom flange of aft fuselage section to forward fuselage bottom honeycomb panel. (See Figure 815.)
- R. Align gusset assemblies in place at bottom edges of forward and aft fuselage sections, (See Figure 816), and secure in place as follows:
- (1) Using CR2248-4-2 Cherry rivets dipped in PR1436GB-2 Inhibited Sealant, rivet gusset to side skin of fuselage. (Thirty-nine (39) CR2248-4-2 Cherry rivets required for each side of fuselage. (See Figure 816 for rivet placement.)
 - (2) Using CR2248-4-3 Cherry rivets dipped in PR1436GB-2 Inhibited Sealant, rivet gusset to side skin of aft fuselage section. (Eight (8) CR2248-4-3 Cherry rivets required for each side of fuselage. (See Figure 816 for rivet placement).
 - (3) Using CR2248-4-4 Cherry rivets dipped in PR1436GB-2 Inhibited Sealant, rivet bottom edge of gusset to bottom skin of aft fuselage section. (Seven (7) CR2248-4-4 Cherry rivets required for each side of fuselage. (See Figure 816 for rivet placement.)
 - (4) Using CR2248-4-2 Cherry rivets dipped in PR1436GB-2 Inhibited Sealant, rivet bottom edge of gusset to bottom skin of forward fuselage section. (Seven (7) CR2248-4-2 Cherry rivets required for each side of fuselage. (See Figure 816 for rivet placement.)
- S. Align reinforcements in place at top edges of forward and aft fuselage sections (See Figure 817) and secure in place as follows:
- (1) Using CR2249-4-2 Cherry rivets dipped in PR1436GB-2 Inhibited Sealant, rivet reinforcement to side skin of forward fuselage section. (Six (6) CR2249-4-2 Cherry rivets required for each side of fuselage. (See Figure 817 for rivet placement.)
 - (2) Using CR2248-4-2 Cherry rivets dipped in PR1436GB-2 Inhibited Sealant, rivet reinforcement to side skin of aft fuselage section. (Eight (8) CR2248-4-2 Cherry rivets required for each side of fuselage. See Figure 817 for rivet placement.)
 - (3) Using CR2249-4-2 Cherry rivets dipped in PR1436GB-2 Inhibited Sealant, rivet upper aft fuselage (turtle deck) skin to top flange of reinforcement. (Five (5) CR2249-4-2 Cherry rivets required for each side of fuselage. See Figure 817 for rivet placement.)
- T. Align canopy track assemblies in place along top edges of forward and aft fuselage sections (See Figure 813) and secure in place as follows:
- (1) Install bolt attaching canopy rail to forward fuselage and upper aft fuselage bulkhead.

AA-5 SERIES
MAINTENANCE MANUAL

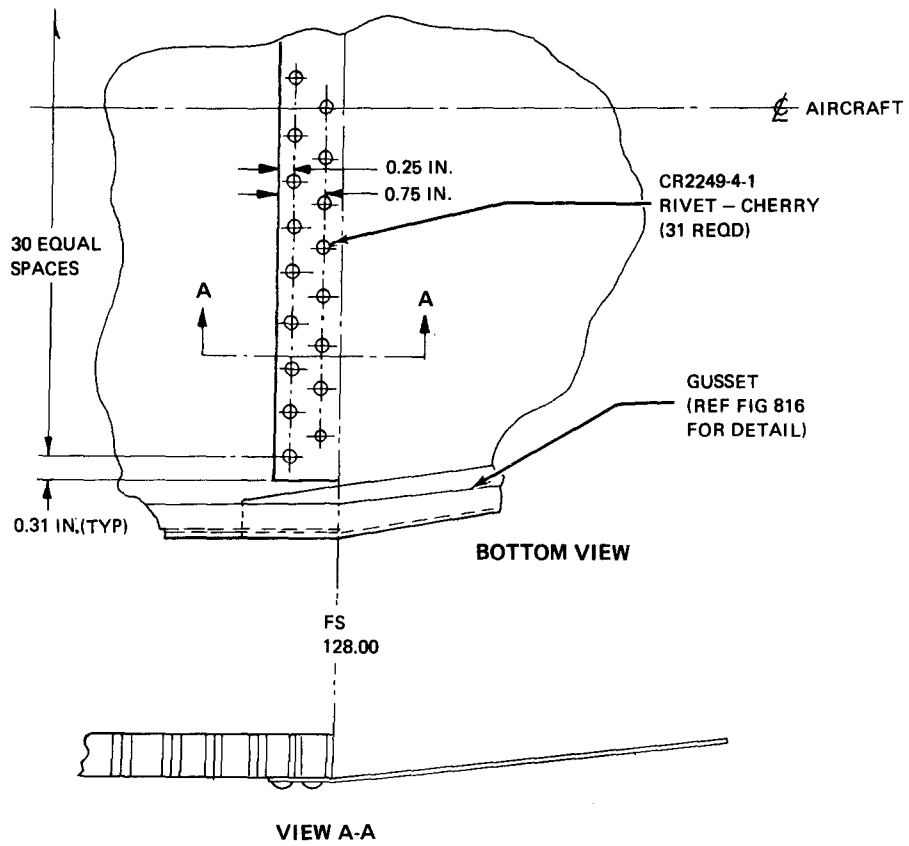

3419

Bottom Skin Attachment Details
Figure 815

**AA-5 SERIES
MAINTENANCE MANUAL**

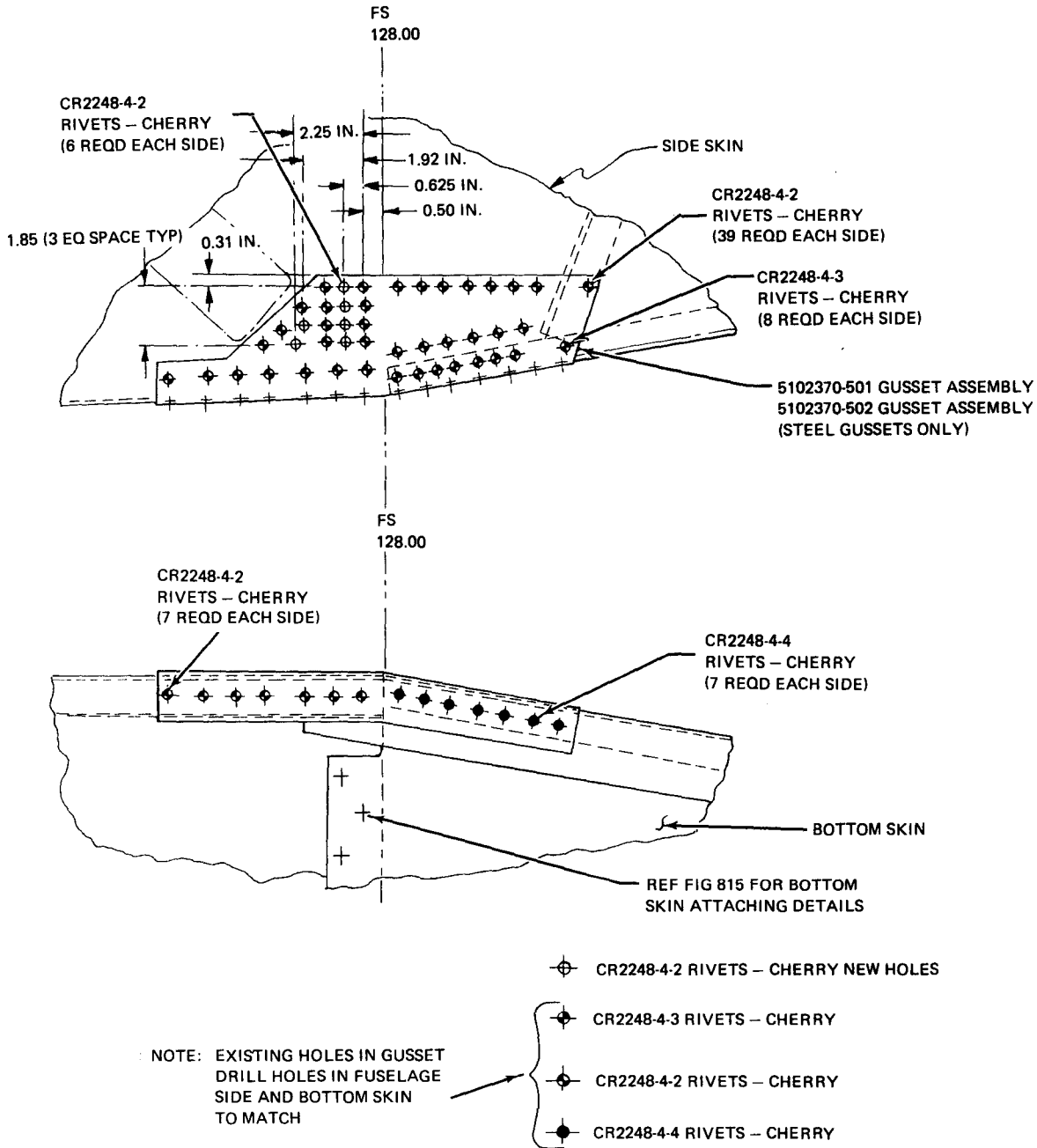

3418

Gusset Attachment Details (L. H. Side)
Figure 816

AA-5 SERIES
MAINTENANCE MANUAL

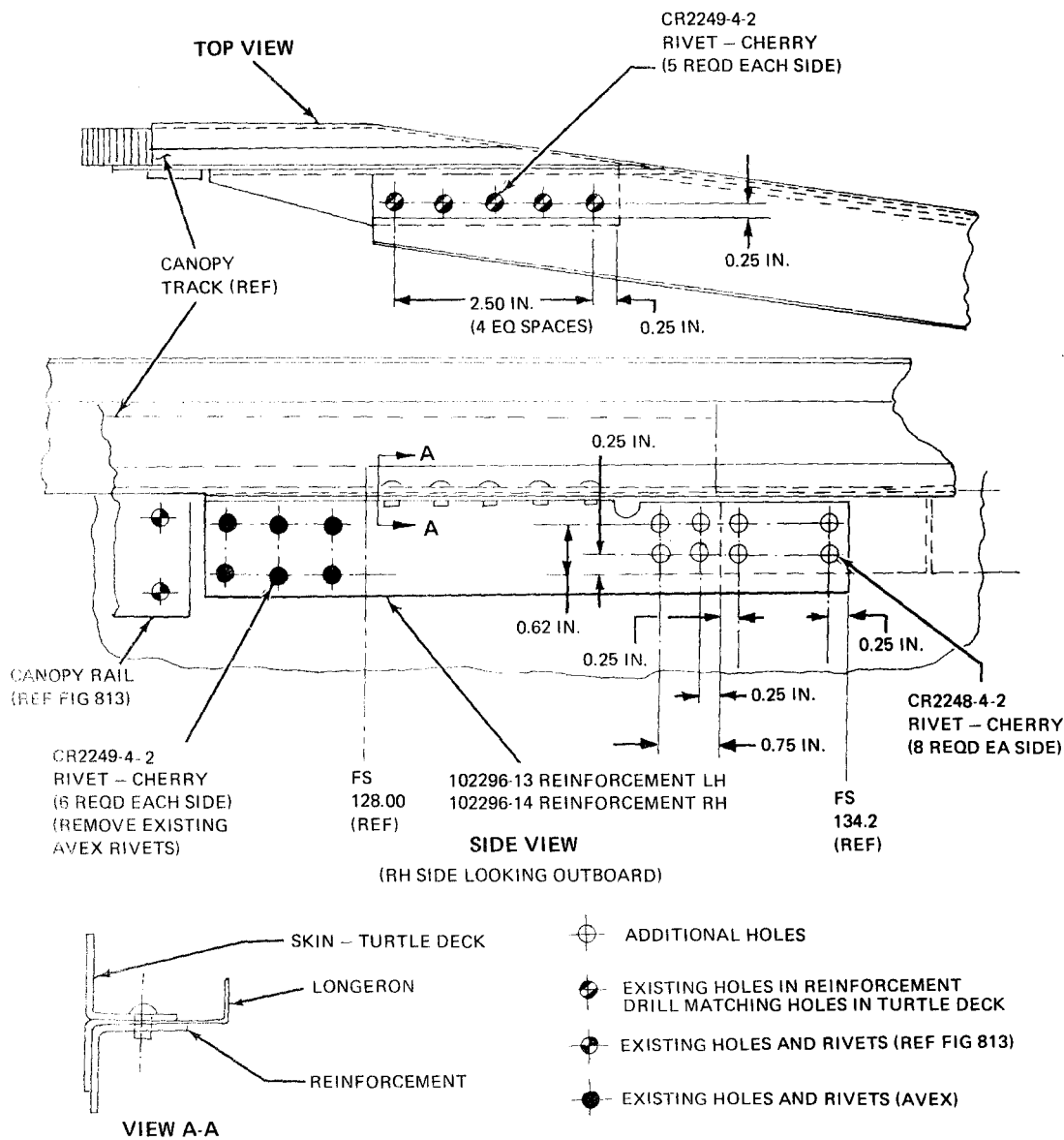

3420

Reinforcement Attachment Details
Figure 817

**AA-5 SERIES
MAINTENANCE MANUAL**

- (2) Using CR2249-4-2 Cherry rivets dipped in PR1436GB-2 Inhibited Sealant, rivet canopy rail to forward fuselage. (Twenty-four (24) CR2249-4-2 Cherry rivets required for each side of fuselage. See Figure 813 for rivet placement.)
- (3) Using MS20470-AD-5 rivets dipped in PR1436GB-2 Inhibited Sealant, rivet canopy rail to upper aft fuselage skin. (Twelve (12) MS20470-AD-5 rivets required for each side of fuselage. See Figure 813 for rivet placement.)
- (4) Install .062 ϕ roll pins on canopy rail. (Four (4) roll pins required for each rail. See Figure 813 for placement of pins.)

- U. Fill over all exterior rivets with epoxy filler and smooth before applying primer.
- V. Coat all repaired areas with zinc chromate primer prior to application of exterior finish paint.
- W. Connect flap actuator motor to motor bracket.
- X. Install vertical and horizontal stabilizers. (See Chapter 55.)
- Y. Connect all rigging cables (see Chapter 27), electrical wiring, and vacuum system tubing at rear seat section of fuselage.
- Z. Rivet two side braces in place connecting the two bulkhead assemblies at rear seat section of fuselage.
- AA. Install wing roots and wings. (See Chapter 57.)
- AB. Install canopy. (See Chapter 52.)
- AC. Install forward and aft side panel interiors. (See Chapter 25.)
- AD. Install rear seat. (See Chapter 25.)

12. Aft Fuselage Bulkhead Replacement

Replace the entire aft fuselage bulkhead (Figure 818) as follows:

- A. Remove rivets attaching aft fuselage bulkhead to ELT mounting bracket and fuselage structure.
- B. Scrape out bond between bulkhead and fuselage structure.
- C. Remove damaged aft fuselage bulkhead.
- D. Using fine grain sand paper, clean away all remaining adhesive before riveting new bulkhead in place.
- E. Coat all joints with zinc chromate primer.

NOTE: Rivet spacing dimensions given below are typical for repairs of the aft fuselage bulkhead.

- F. Secure new bulkhead assembly to fuselage with MS20426AD4-5 rivets installed wet with zinc chromate primer. (Install 19 rivets to right fuselage side, 19 rivets to the left side, and 15 rivets to bottom side.)
- G. Secure new bulkhead assembly to panel assembly flanges with six (6) 1601-0410 Avex rivets installed wet with zinc chromate primer.
- H. Fill over exterior rivets with epoxy filler and smooth before applying primer.
- I. Coat repaired area with zinc chromate primer prior to application of exterior finish paint.

AA-5 SERIES
MAINTENANCE MANUAL

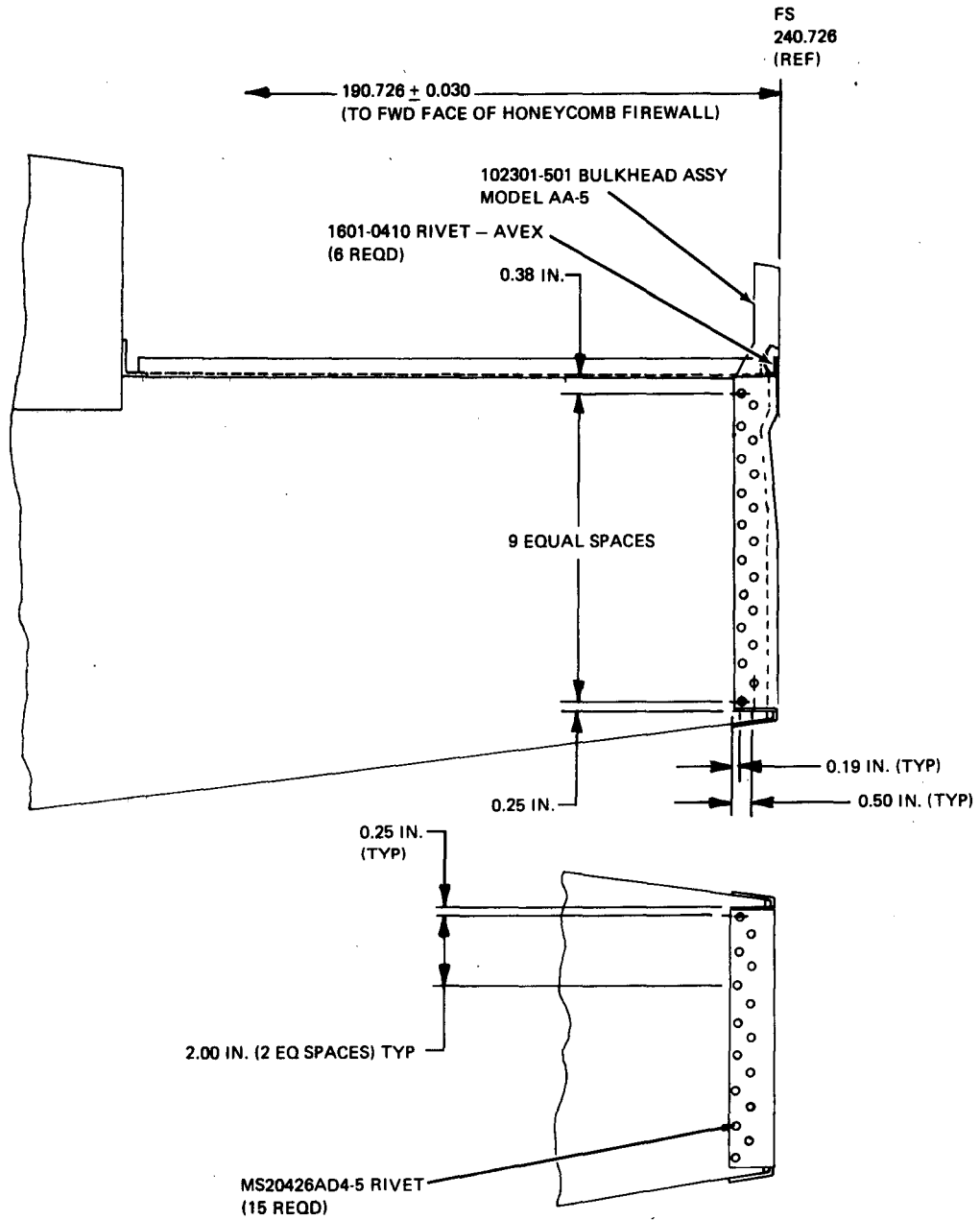

3098

Aft Fuselage Bulkhead Replacement
Figure 818

13. Bondline Repair

If inspection of joint edges determine the existence of hairline cracks between two layers of bonded metal, perform the following steps:

- A. Identify the location of any cracks with a grease pencil as shown in Figure 819 below:

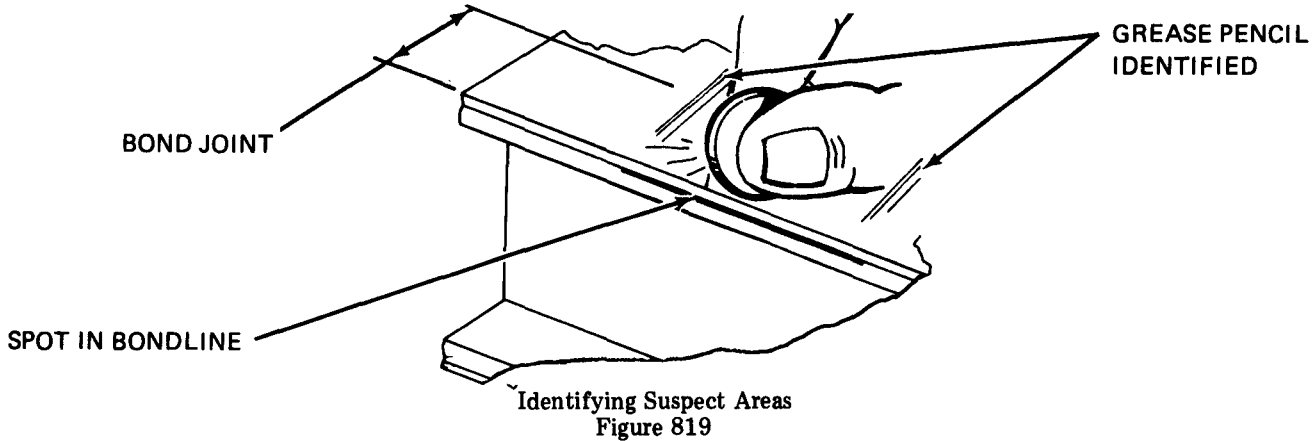

- B. Gently tap the bondline with a coin or similar metal object to verify the existence of a bondline separation. Slowly move along the bondline while tapping, and listen for a change in tone as the suspect area is traversed. A bondline separation will produce a flat or hollow sound when "tapped" directly in the damaged area.
- C. If the results of Step B above are questionable, insert a 0.004 inch to 0.006 inch feeler gauge into the bondline to verify that a separation exists.

WARNING: WHEN USING TRICHLOROETHANE, ENSURE THAT THE WORKING AREA IS WELL VENTILATED AND THAT PROTECTIVE EQUIPMENT (GLOVES, EYE PROTECTION) IS WORN. AVOID BREATHING FUMES. KEEP AWAY FROM FLAMES.

- D. If the results of Steps B and C are negative, the hairline should be wiped with Trichloroethane and sealed with paint. Also, any bare bondline edges should be sealed with paint. If the results of either Steps B or C are positive, order Service Kit No. SK-125 from your authorized Grumman American Dealer or Distributor and make the repairs accordingly.

14. Main Gear Strut Repair

The following main gear strut repair procedure covers surface delaminations which do not extend more than one ply into the surface of the strut and corner delamination which are smaller than 1/16 x 1/16 inch in size throughout their length.

- A. Remove delaminated material.
- B. Smooth out minor paint chips or stone bruises with No. 150 Tri-Mite.

WARNING: WHEN USING TRICHLOROETHANE, ENSURE THAT THE WORKING AREA IS WELL-VENTILATED AND THAT PROTECTIVE EQUIPMENT (GLOVES, EYE PROTECTION) IS WORN. AVOID BREATHING FUMES. KEEP AWAY FROM FLAMES.

- C. Clean unpainted areas thoroughly with Trichloroethane.
- D. Seal minor surface or corner delaminations with a two-part epoxy adhesive to seal out moisture from the damaged area.
- E. Clean strut with wax and grease remover.
- F. Prime with two light coats of zinc chromate primer per MIL-P-8585 and paint to match aircraft color.

**AA-5 SERIES
MAINTENANCE MANUAL**

15. Damaged or Delaminated Spar Collar Repair

The following repair is applicable to all AA-5 aircraft. The repair is for any forward or aft rib to spar collar and may be used separately, or in conjunction with other approved repairs providing that no spar damage has occurred. If collar is not delaminated from spar, refer to Paragraph 2., this Section for repair.

If collar is delaminated from spar, repair as follows:

CAUTION: DO NOT USE STEEL WOOL OR SILICON GRIT ABRASIVES. USE EXTREME CARE NOT TO SCRATCH OR GOUGE SPAR.

- A. Clean area to be repaired by removing loose bonding material using aluminum wool, 3-M ELEKTRO-CUT cloth or aluminum oxide paper. Thoroughly clean area using a vacuum cleaner or other suitable means.

WARNING: USE CLEANING SOLVENTS IN A WELL VENTILATED AREA. AVOID BREATHING FUMES. KEEP AWAY FROM FLAME.

- B. Clean area with a lint-free cheese cloth dampened with MEK, alcohol (99% Isopropyl), or acetone until cloth shows no sign of smudge or stain.
- C. Inspect collar for damage and replace if required. If using old collar, ensure it is clean.
- D. Locate collar in correct position and drill (as shown in Figure 820) for MS20470AD4 or NAS1919B04 (or equivalent) rivets.
- E. Remove collar and deburr holes.

CAUTION: OBSERVE ALL PRECAUTIONS NOTED IN KIT INSTRUCTIONS IN THE USE OF SEALANTS, AND WORKINGS IN FUEL TANK AREAS.

- F. Prepare sealant per Single Engine Service Kit No. SK-125A, or if in fuel tank area per SK-140A. Coat mating surface with sealant and rivet into place. Coat rivets with proper sealant before insertion.

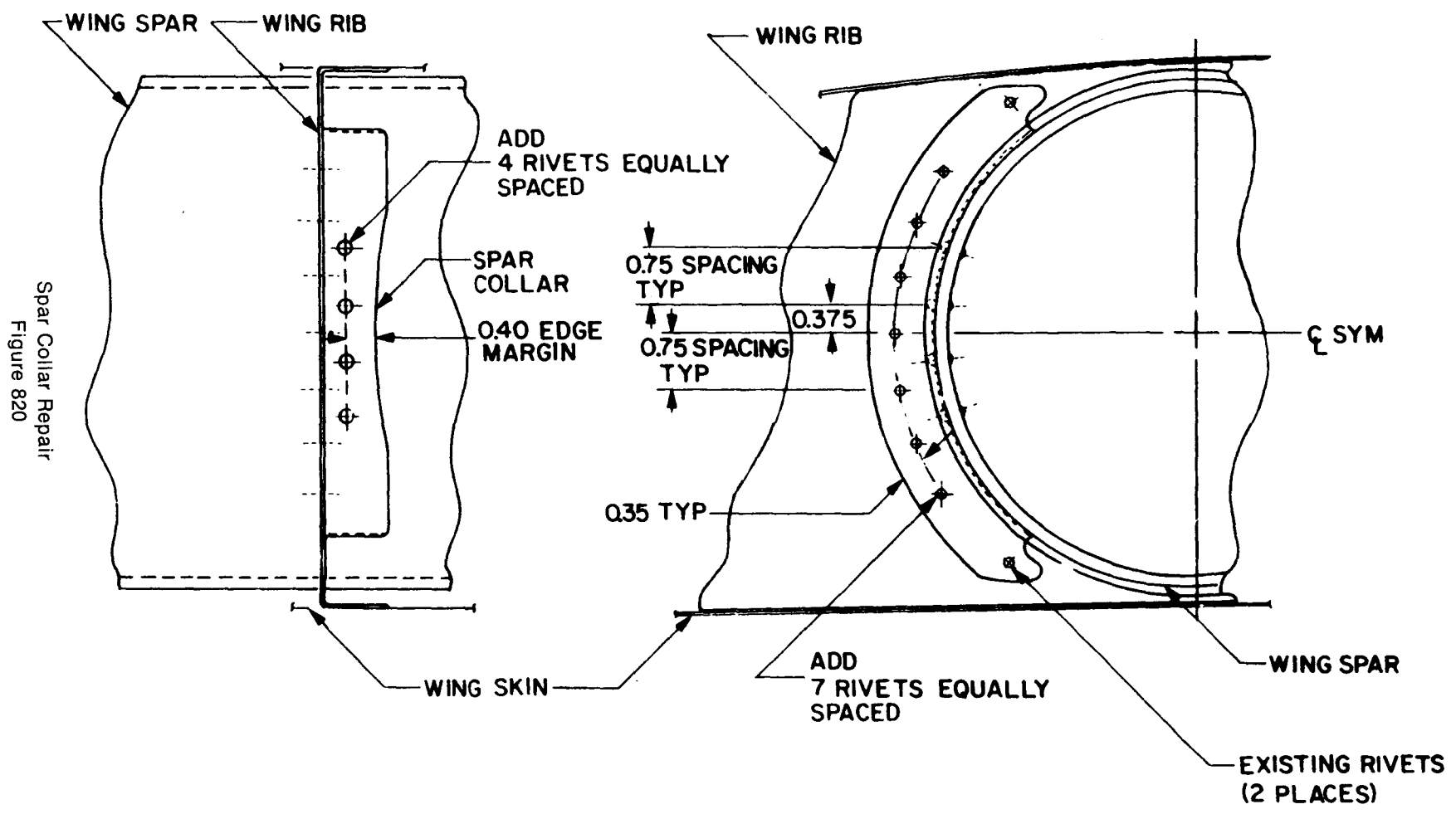

Spar Collar Repair
Figure 820

**AA-5 SERIES
MAINTENANCE MANUAL**

PREPARATIONS FOR PAINTING - DESCRIPTION

1. General

The three basic steps involved in the preparation of the aircraft for painting are stripping, cleaning and priming. The directions given in this section are intended to establish procedures for preparing the aircraft for painting. Procedures for the stripping, cleaning, and application of a metal conditioner are presented in this section.

The requirements specified in this section shall apply to all polyurethane coated aircraft manufactured by the Grumman American Aviation Corporation. Any deviation from or modification of these directions shall be approved by the Customer Service Department.

Because paint strippers are formulated to remove a synthetic substance, it must be understood that they are detrimental to all substances of the synthetic family. For this reason, the following procedure has been prepared and must be carefully followed to ensure against damage to synthetic components on the aircraft.

**AA-5 SERIES
MAINTENANCE MANUAL**

PREPARATIONS FOR PAINTING — CLEANING/PAINTING

1. Stripping and Cleaning Procedure

Reference Specifications:

MIL-R-25134B — Paint and Lacquer, Solvent Type Remover.

GAPS-1057 (GAAC) — Application of Protective and Decorative Coatings

WARNING: WHEN USING TRICHLOROETHANE, ENSURE THAT THE WORKING AREA IS WELL-VENTILATED AND THAT PROTECTIVE EQUIPMENT (GLOVES, EYE PROTECTION) IS WORN. AVOID BREATHING FUMES. KEEP AWAY FROM FLAMES.

CAUTION: LONG TERM EXPOSURE OR BOND JOINTS TO PAINT STRIPPERS WILL AFFECT THE INTEGRITY OF THE BOND STRENGTH. ALL AREAS MUST BE COMPLETELY SEALED TO PREVENT THE STRIPPER FROM CONTACTING BOND JOINTS OR GETTING INTO INTERNAL AREAS OF THE AIRCRAFT. IF STRIPPER DOES INADVERTENTLY CONTACT THE BOND JOINT, FLUSH THOROUGHLY WITH TAP WATER WITHIN 1-1/2 HOURS.

- A. Wipe all bondlines and areas with Trichlorethane or a suitable substitute so that they will be free of dust, oily material, wax, cleaning agents or other foreign material.

CAUTION: APPLY PROTECTIVE TAPE TIGHTLY TO ENSURE AGAINST SEEPAGE OF STRIPPER INTO THE AREAS MENTIONED IN B AND C BELOW.

- B. Using 2 inch wide aluminum tape, mask windows, windshield, wing tips, stabilizer tips, wing roots, nose cowl, tailcone, propeller, main landing gear, drain holes, fasteners and all bondlines as shown in the shaded areas of Figure 701.
- C. Encase antennas, lights, beacons, tires, radar domes, windows, windshield and all fiberglass or plastic parts in a double layer of aluminum foil as indicated by cross hatching in Figure 701.
- D. Apply approved polyurethane stripper with a suitable paint brush with slow easy strokes so as not to apply stripper on any undesired areas. Allow the stripper to work for 5 to 15 minutes.

NOTE: Acceptable material sources for polyurethane strippers per MIL-R-25134B are:

- (1) Strip-prep No. 66
Amchem Products, Incorporated
2300 Gainsboro
Ferndale, Michigan 48220
- (2) Methylene Chloride Based Paint Stripper No. 3403
W. M. Barr and Company
2336 S. Lauderdale
Memphis, Tennessee 38106

- E. Flush removed paint and excess stripper with tap water, using a pressure nozzle, being sure that all stripper residue is thoroughly removed.
- F. Remove the aluminum tape and protective foil from all areas. Inspect these areas carefully to be sure all stripper residue has been removed.

NOTE: It is permissible to sand the paint completely from the bond lines; however, for best bondline protection, it is recommended that these areas be lightly sanded.

- G. After removing the tape and protective foil, sand and feather the paint edge in all areas which had been protected from the stripper.

AA-5 SERIES
MAINTENANCE MANUAL

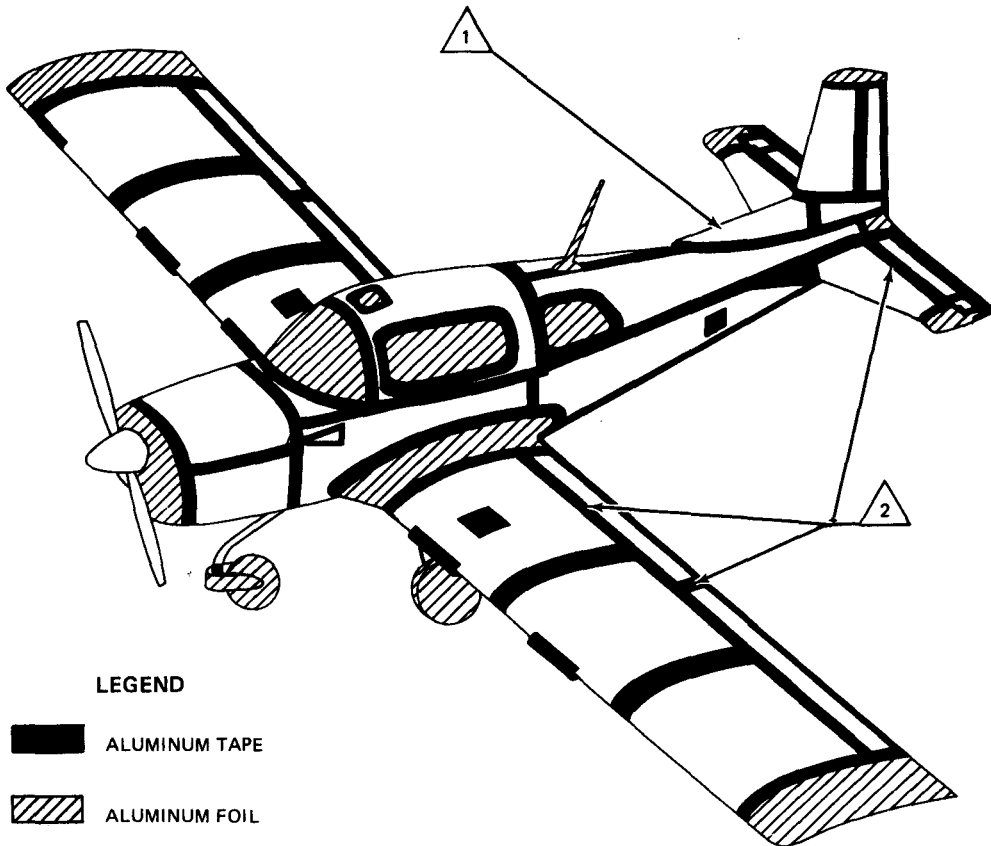

LEGEND

■ ALUMINUM TAPE

▨ ALUMINUM FOIL

3102

1 IF AIRCRAFT HAS PLASTIC DORSAL FIN (1974 AND ON), IT MUST BE PROTECTED WITH ALUMINUM FOIL.

2 SEAL ALL GAPS BETWEEN SURFACES AS SHOWN PRIOR TO APPLICATION OF STRIPPER.

Aircraft Stripping (Sheet 1 of 2)
Figure 701

AA-5 SERIES
MAINTENANCE MANUAL

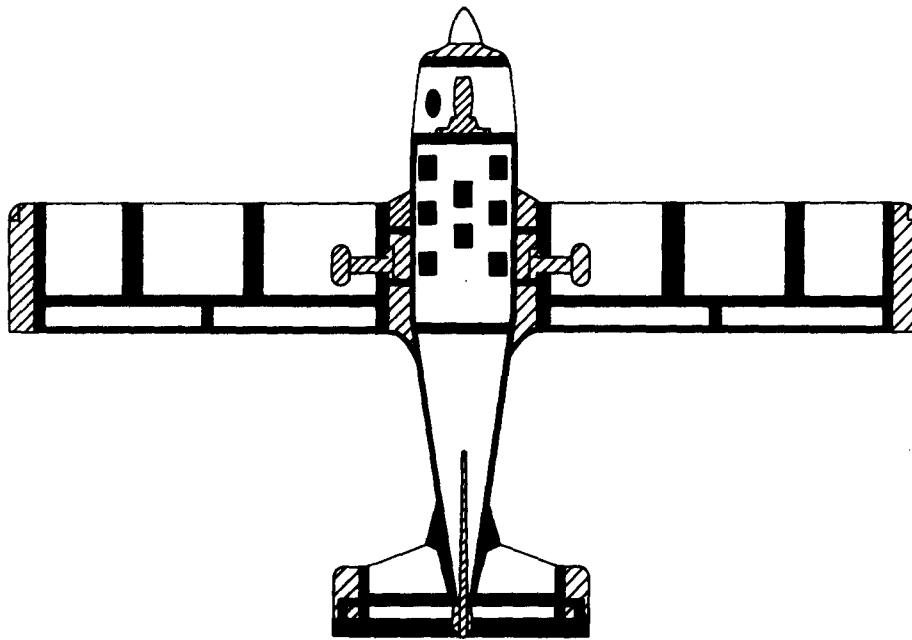

BOTTOM VIEW

3103

-  ALUMINUM TAPE
-  ALUMINUM FOIL

Aircraft Stripping (Sheet 2 of 2)
Figure 701

2. Metal Conditioner Application

- A. Prepare metal conditioner solution (See Note below) using manufacturer's instructions.

NOTE: Acceptable material sources for metal conditioners are:

- (1) Dupont 225 Metal Conditioner
 - (2) Magnus No. 852 (wipe off) Metal Conditioner
Economics Laboratory, Incorporated
Magnus Division
Osborn Building St. Paul, Minnesota 55102
- B. Apply the conditioner by wiping or brushing the solution on all surfaces to be painted. This compound is safe for use on bond joints. Do not allow conditioner to contact the windshield or windows.
- C. Allow the conditioner to work for 2 to 10 minutes depending on the degree of surface cleanliness.
- D. Remove the conditioner per manufacturer's instructions.

AA-5 SERIES
MAINTENANCE MANUAL

CHAPTER 21

AIR CONDITIONING

TABLE OF CONTENTS

| <u>NUMBER</u> | | <u>PAGE</u> |
|---------------|-----------------------|-------------|
| 21-0 | AIR CONDITIONING | |
| | Description/Operation | 1 |
| | General | 1 |
| 21-2-1 | VENTILATION SYSTEM | |
| | Description/Operation | 1 |
| | General | 1 |
| 21-4-1 | HEATING SYSTEM | |
| | Description/Operation | 1 |
| | General | 1 |
| | Troubleshooting | 101 |
| | Maintenance Practices | 201 |
| | General | 201 |

**AA-5 SERIES
MAINTENANCE MANUAL**

AIR CONDITIONING - DESCRIPTION/OPERATION

1. General

Air conditioning, as applicable to this aircraft, is defined as any method used to maintain a desired level of heating, ventilating, or controlling the air within the occupied areas of the aircraft. The system consists of the components and associated controls used for heating and ventilating the aircraft cabin. The system is a completely mechanical system and is manually controlled. The cabin heat control is a push-pull type control located in the lower center of the instrument panel. Each air vent has an individual control. The air vent control for the forward cabin area is a push-pull type control located at the lower corners of the instrument panel adjacent to the louvered outlets. A rear air vent system is available as an optional installation.

**AA-5 SERIES
MAINTENANCE MANUAL**

VENTILATION SYSTEM - DESCRIPTION/OPERATION

1. General

Forward cabin area ventilation is provided by two ventilators, (Figure 1) one in each side of the fuselage. The ventilators are controlled by manually adjustable valves for quantity of air. The flow of fresh air in the cabin can be regulated in the desired direction by movable louvers located in the air vent outlets.

Ventilation for the rear seat area of the cabin is furnished as an optional installation. The air vents for the rear cabin area are located on each side of the fuselage at the rear seat location (Figure 2). The flow of air inside the cabin can be regulated or shut off completely by rotating the knurled ring on the outlet valve.

AA-5 SERIES
MAINTENANCE MANUAL

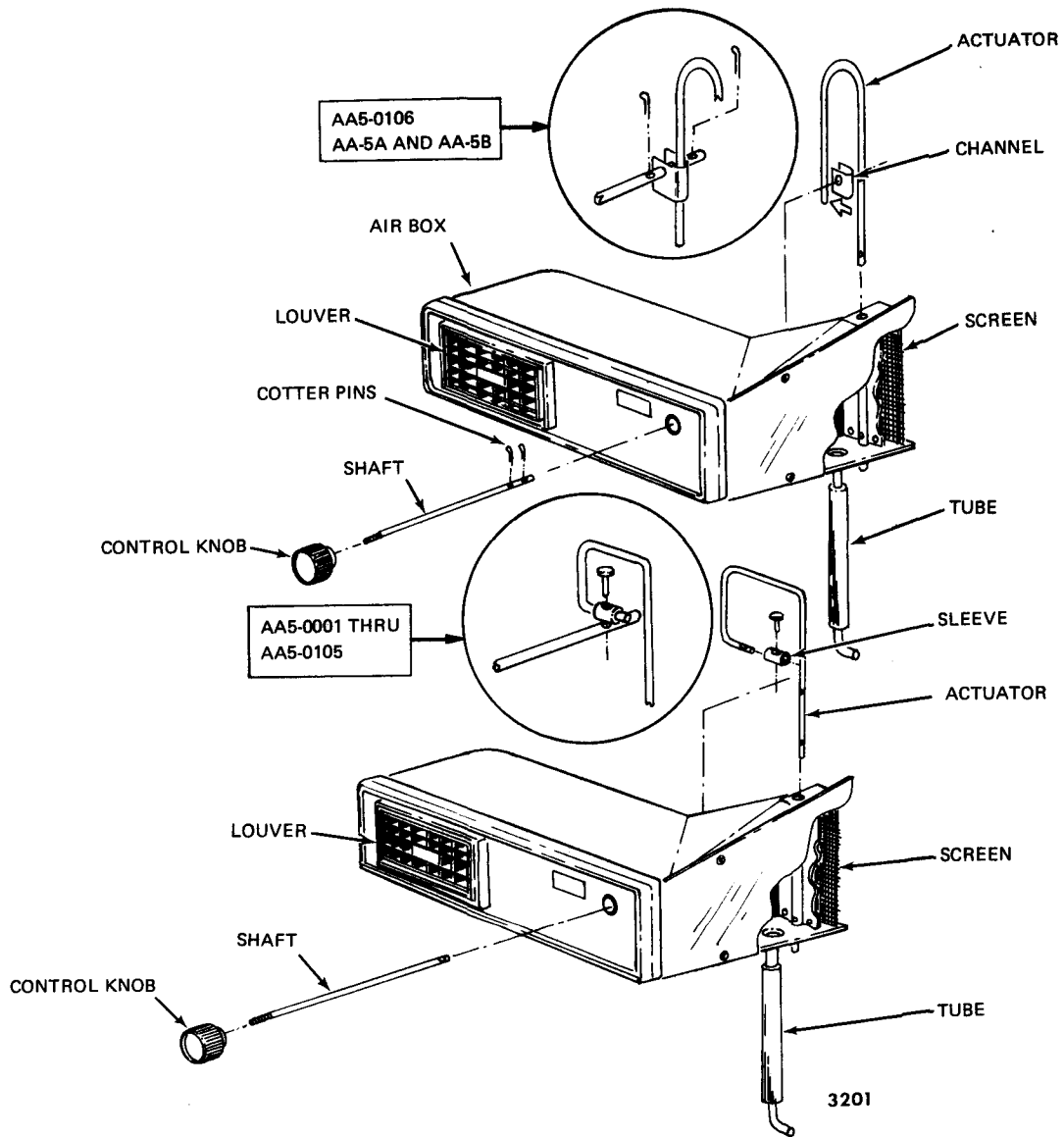

Forward Cabin Area Air Vent System
Figure 1

AA-5 SERIES
MAINTENANCE MANUAL

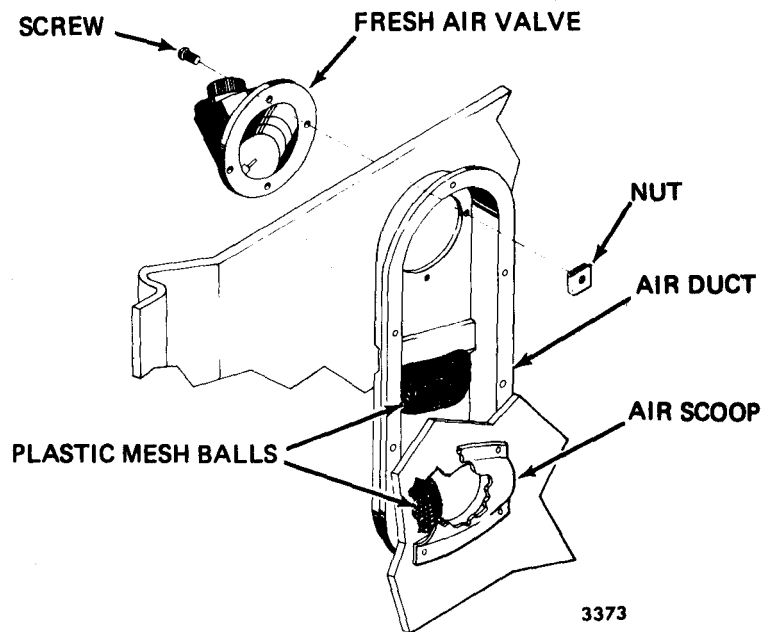

OUTSIDE AIR SCOOP

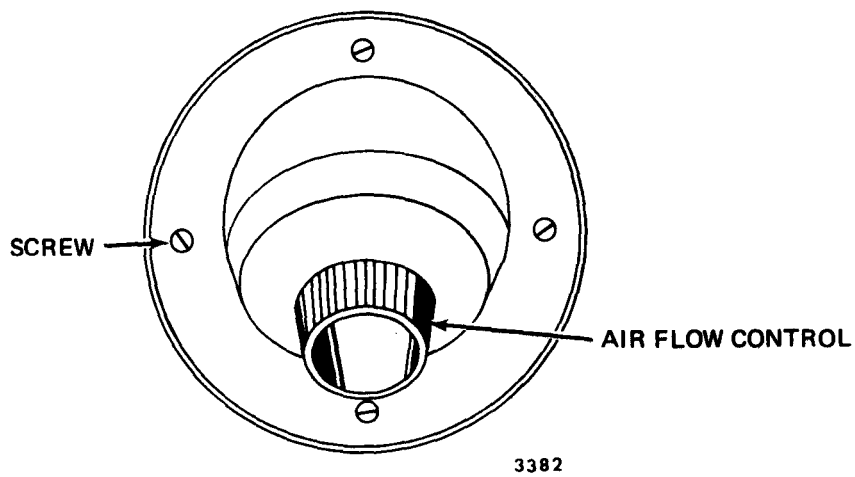

OUTLET VALVE

Rear Cabin Area Air Vent System
Figure 2

**AA-5 SERIES
MAINTENANCE MANUAL**

HEATING SYSTEM - DESCRIPTION/OPERATION

1. General

The cabin heating system is basically a controlled air flow in which air passes over the muffler core and is ducted into the cockpit. The amount of heated air is regulated by a valve mounted through the firewall. Cool air picked up by the nose cowl inlet serves two purposes, that of cooling the muffler, and providing heated air for comfort.

A Y-adapter in the engine compartment mixes a stream of cold air with the hot air from the heat exchanger to provide good heat distribution and flow. The valve mounted through the firewall is used to regulate the warm air by either ducting it overboard or into the cabin as desired. The amount the push-pull control is moved determines the amount of heat ducted into the cabin.

To provide for windshield defrosting, flexible ducts are connected to the valve and terminated just below the sliding doors located on the forward panel deck. Operation of the defroster is accomplished by pulling the push-pull control out and opening the sliding doors.

AA-5 SERIES
MAINTENANCE MANUAL

HEATING SYSTEM – TROUBLESHOOTING

| TROUBLE | PROBABLE CAUSE | REMEDY |
|--------------------------|---------------------------------|--|
| Insufficient Heat. | Duct damaged or disconnected. | Replace or connect duct |
| | Loose control cable connection. | Tighten control cable connection. |
| | Air valve damaged. | Replace air valve. |
| Control hard to operate. | Control cable binding. | Check cable for proper routing and free the cable. |
| | Air valve sticking or binding | Lubricate valve stem bearing and free the valve. |
| Exhaust fumes in cabin. | Defective muffler | Inspect muffler and replace if defective. |

**AA-5 SERIES
MAINTENANCE MANUAL**

HEATING SYSTEM — MAINTENANCE PRACTICES

1. **General**

Maintenance of the Heating system (Figures 201, 202, and 203) will probably be confined to replacement of ducting when damaged. Ducts can be replaced by removing clamp and duct and installation of new ducts.

AA-5 SERIES
MAINTENANCE MANUAL

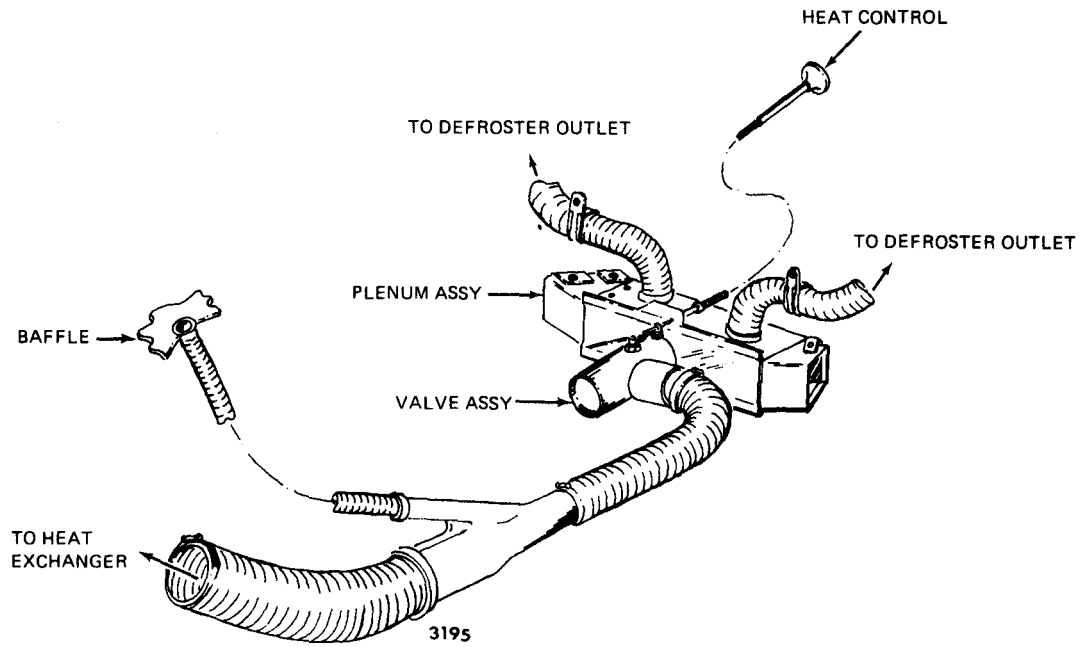

Heating System — AA5-0001 thru 0834, AA5A-0001 thru 0522
Figure 201

**AA-5 SERIES
MAINTENANCE MANUAL**

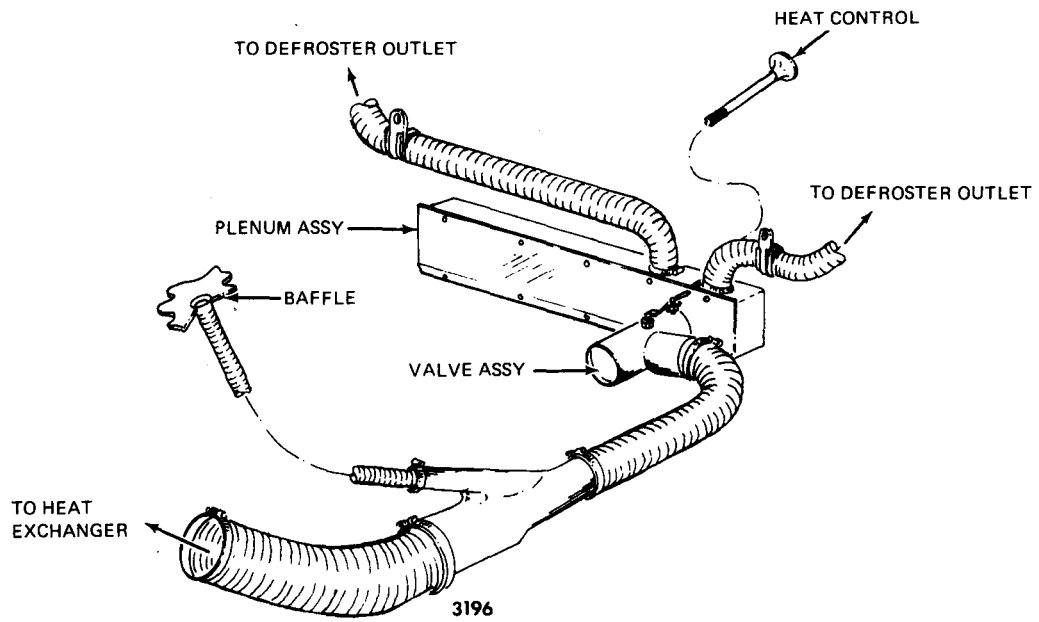

Heating System — AA-5B 0001 thru 0280, 0283, and 0284
Figure 202

AA-5 SERIES
MAINTENANCE MANUAL

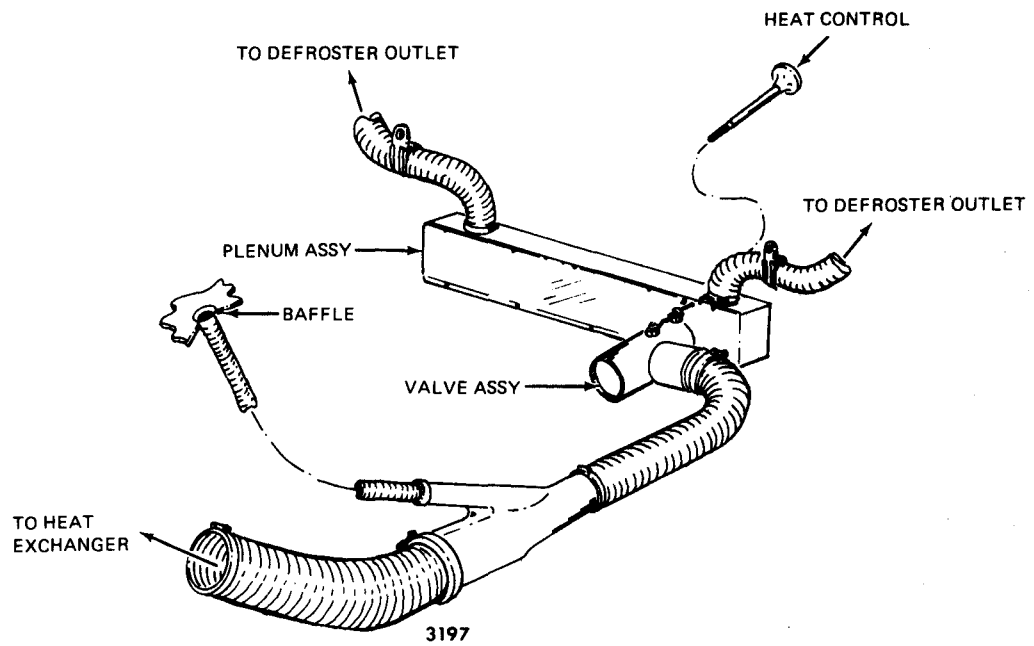

Heating System — AA5B-0281, 0282 and 0285 thru 0399
Figure 203

**AA-5 SERIES
MAINTENANCE MANUAL**

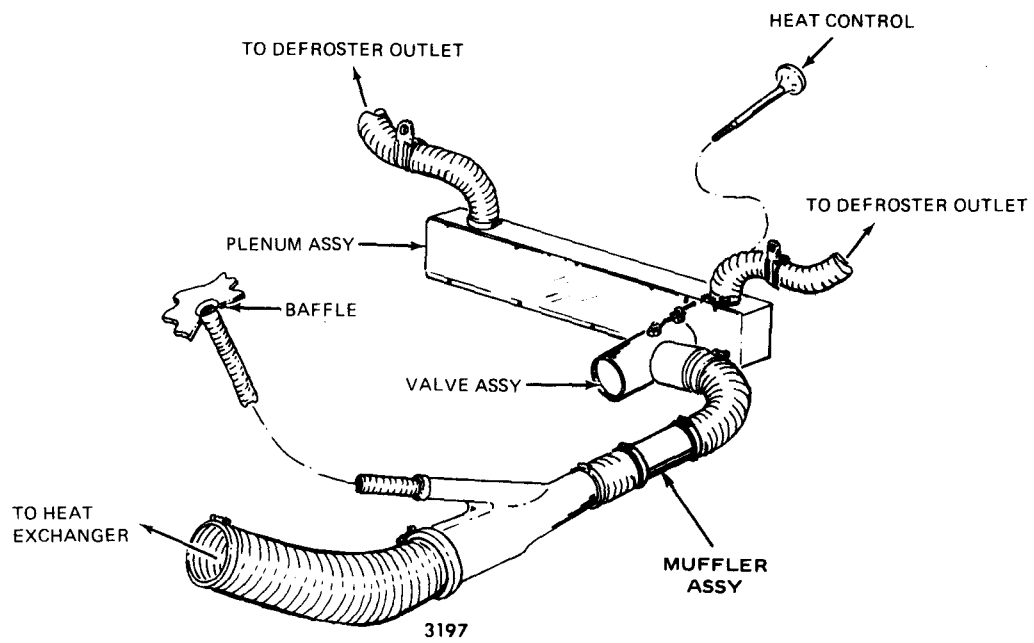

Heating System — AA5A-0523 and Subsequent, AA5B-0400 and Subsequent
Figure 204

AA-5 SERIES
MAINTENANCE MANUAL

CHAPTER 22

AUTOPILOT

TABLE OF CONTENTS

| <u>NUMBER</u> | | <u>PAGE</u> |
|---------------|-----------------------------------|-------------|
| 22-0 | AUTOPILOT | |
| | Description | 1 |
| | General | 1 |
| 22-1-1 | AUTOPILOT SYSTEM | |
| | Description/Operation | 1 |
| | Century I | 1 |
| | Century IIB | 1 |
| | Maintenance Practices | 201 |
| | Roll Servo - Removal/Installation | 201 |

AUTOPILOT - DESCRIPTION

1. General

The Grumman American AA-5, AA-5A and AA-5B utilizes an Edo-Aire Mitchell Century I or Century IIB Autopilot as optional equipment.

The Edo-Aire Mitchell Century I is a light weight all electronic stabilization system contained in two compact units.

The panel mounted unit contains a pictorial turn and bank stabilizer electronics, optional tracker electronics, turn command control, roll trim control and tracker switching. The roll servo motor is the other unit and it is mounted in the cabin beneath the console.

The roll servo incorporates a fail safe engage and disengage mechanism to provide complete control freedom upon disengagement. Engagement and disengagement is controlled by a panel mounted stabilizer master switch.

In addition to these switches, safety override features permit the pilot to override the system at any time without damage to the servo or aircraft controls.

The Edo-Aire Mitchell Century IIB is a light weight automatic flight system utilizing an advanced electronic design for maximum performance and utility. Operating on the versatile 5000 cycle audio frequency, the Century IIB represents a design concept in which the conventional follow-up or control position feedback signals are replaced by solid state analytical computers. In addition to providing a more stable and adaptable platform, the new system can cope with uneven fuel loads without the usual directional errors.

Roll responses are time controlled for human-like control action and smooth heading changes.

This chapter will consist of block diagrams, (Figures 1 and 2) wiring diagrams, (Figures 3 through 5) and the removal/installation of the roll servo (Figure 6) used on the Century I and Century IIB Autopilot. For details on the autopilot, refer to the applicable Edo-Aire Mitchell manual.

**AA-5 SERIES
MAINTENANCE MANUAL**

AUTOPILOT SYSTEM - DESCRIPTION/OPERATION

For information concerning the description and operation of the Century I and IIB Autopilot, refer to the applicable Edo-Aire Mitchell manual.

AA-5 SERIES
MAINTENANCE MANUAL

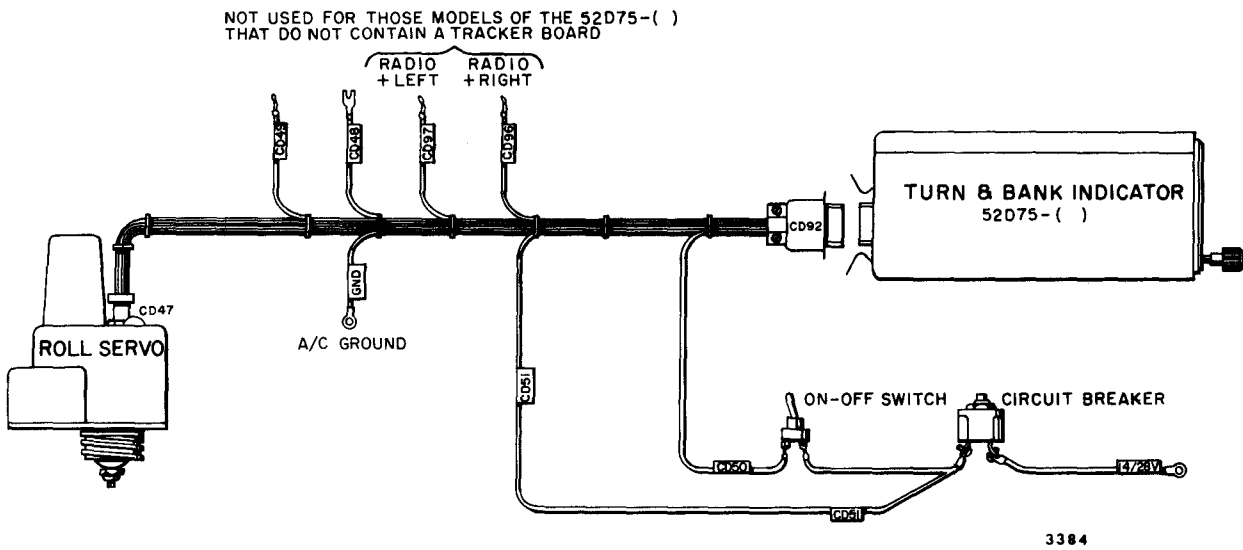

Century I Autopilot - Block Diagram
Figure 1

**AA-5 SERIES
MAINTENANCE MANUAL**

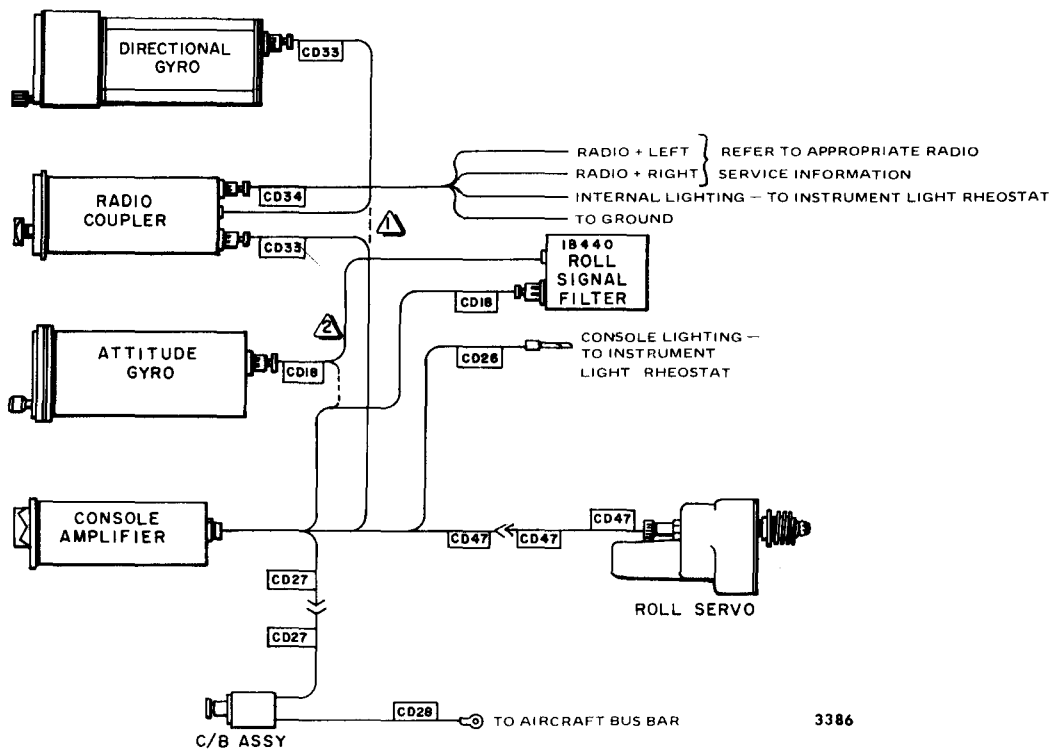

- NOTES:**
- ⚠ IF RADIO COUPLER IS NOT INSTALLED, CD-33 IS TO BE CONNECTED DIRECTLY TO THE 52054 DIRECTIONAL GYRO. THE 1C388MC RADIO COUPLER IS TO BE USED IN CONJUNCTION WITH STANDARD ARINC COMPASS SYSTEMS. FOR PIN TERMINATIONS AT CD-33 & CD-34, REFER TO DWG. 63B149.
 - ⚠ IF 1B440 ROLL SIGNAL FILTER IS NOT USED, PLUG CD-18 OF CABLE ASSEMBLY 30C198-() DIRECTLY TO S2066 ATTITUDE GYRO.

Century IIB Autopilot - Block Diagram
Figure 2

**AA-5 SERIES
MAINTENANCE MANUAL**

EDO-AIRE AUTOPILOT

AA5-0830 AND SUBSEQUENT
AA5A-0001 AND SUBSEQUENT
AA5B-0093 AND SUBSEQUENT

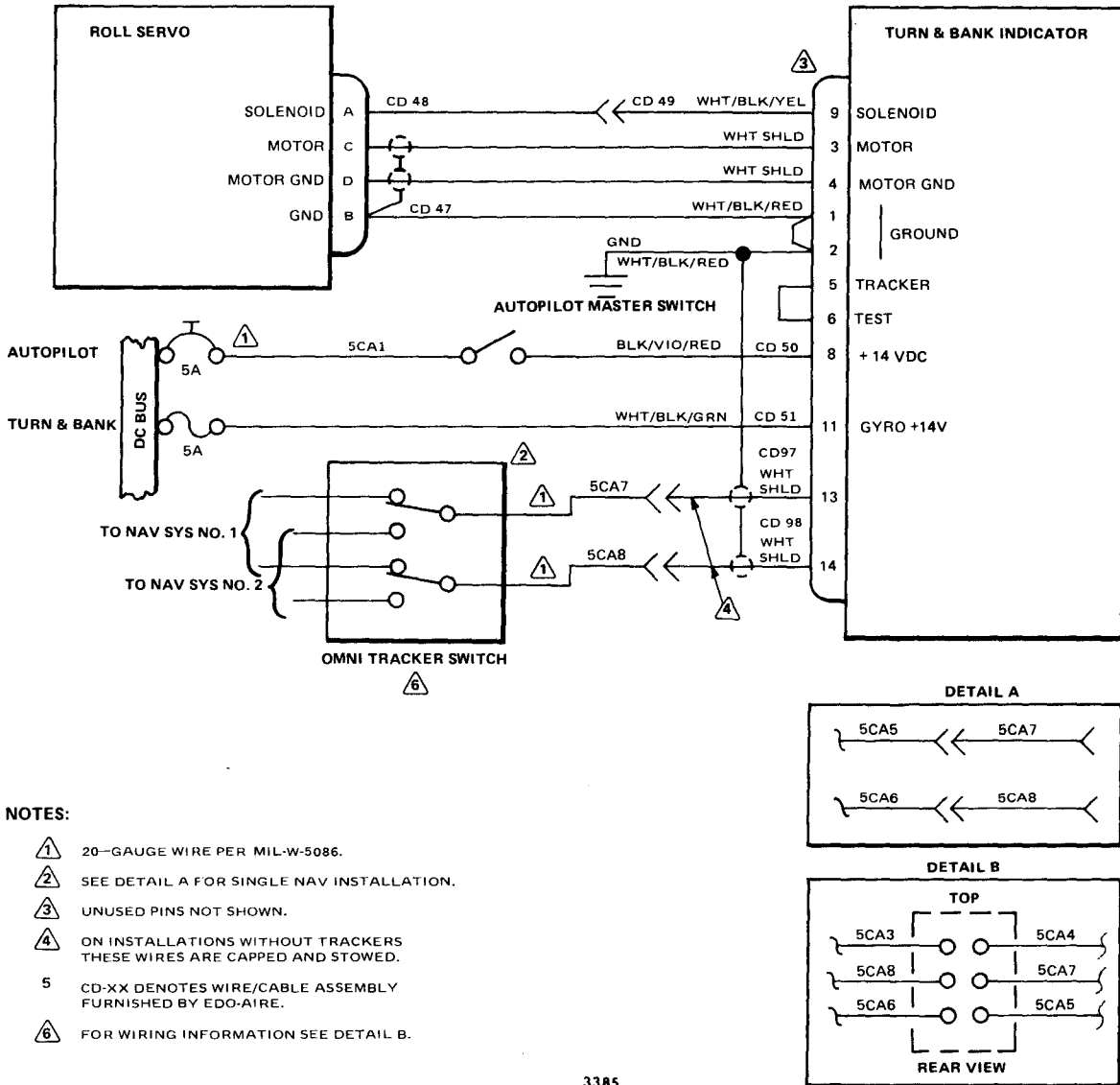

3385

Century I Autopilot - Wiring Diagram
Figure 3

**AA-5 SERIES
MAINTENANCE MANUAL**

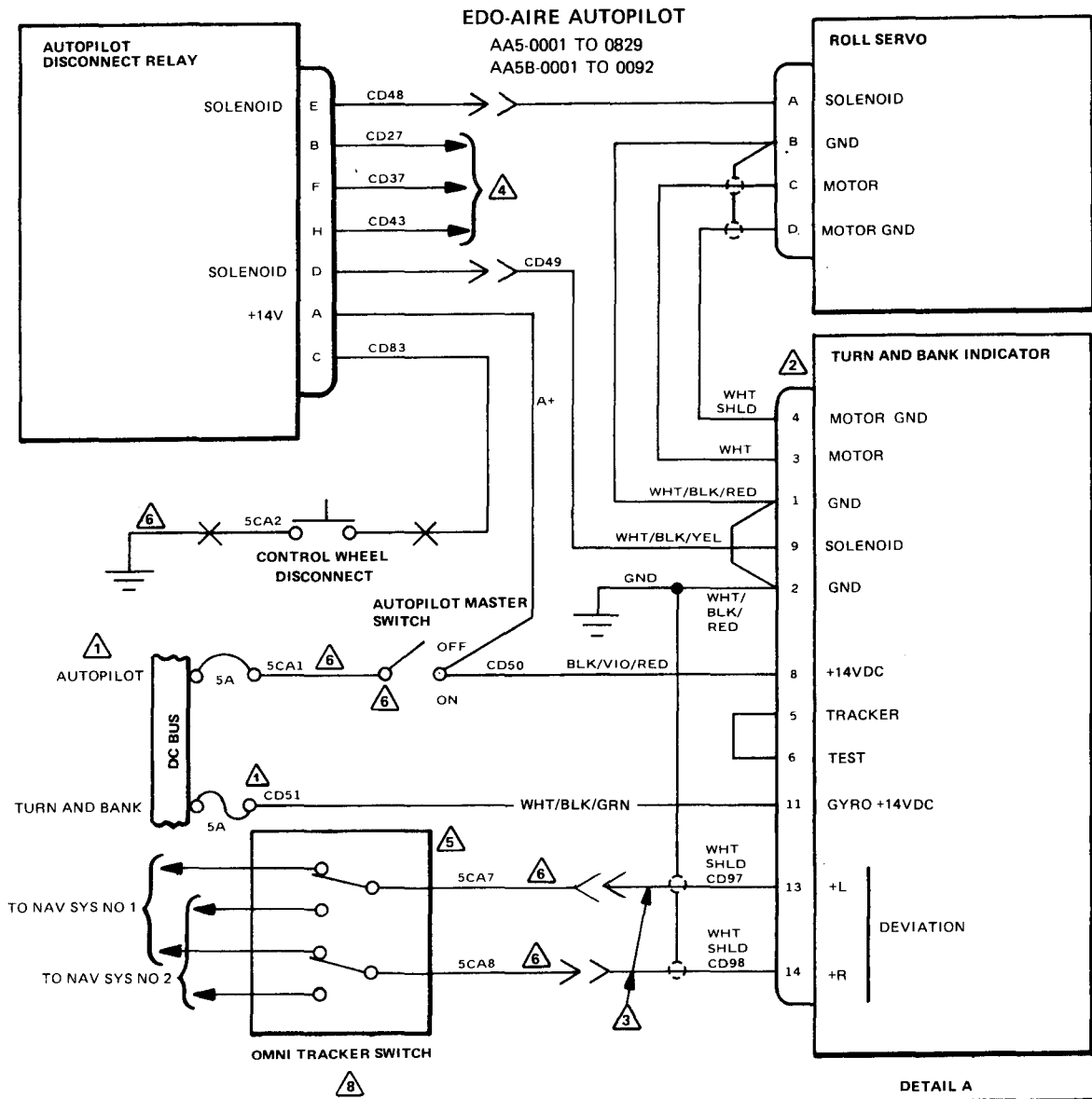

- NOTES**
- 1 ON AA5-0001 TO 0405, THIS WIRE REPLACES 5CA1 AND AUTOPILOT CIRCUIT BREAKER
 - 2 UNUSED PINS NOT SHOWN
 - 3 ON AIRCRAFT WITHOUT TRACKERS THESE WIRES ARE CAPPED AND STOWED
 - 4 THESE WIRES ARE CAPPED AND STOWED
 - 5 SEE DETAIL A FOR SINGLE NAV INSTALLATION
 - 6 20 GAUGE WIRE PER MIL-W-5086
 - 7 CD-XX DENOTES WIRE/CABLE ASSEMBLY FURNISHED BY EDO-AIRE
 - 8 FOR WIRING INFORMATION SEE DETAIL B

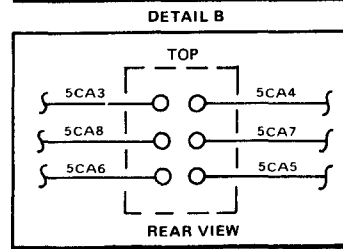
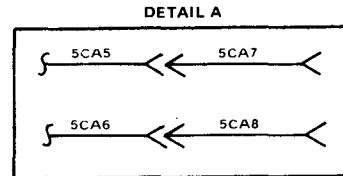

3391

Century IIB Autopilot Wiring Diagram
Figure 4

**AA-5 SERIES
MAINTENANCE MANUAL**

EDO-AIRE CENTURY IIB AUTOPILOT-NAV INTERFACE

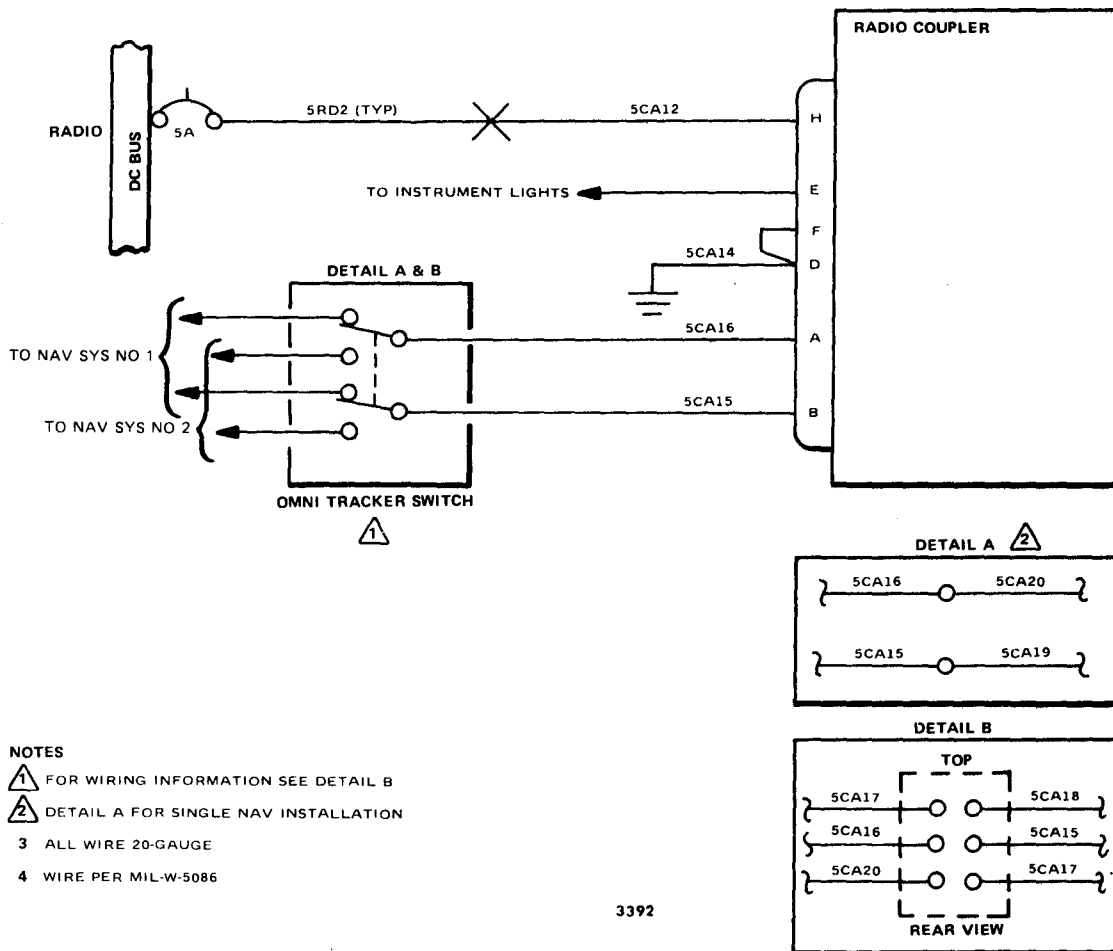

NOTES

- 1 FOR WIRING INFORMATION SEE DETAIL B
- 2 DETAIL A FOR SINGLE NAV INSTALLATION
- 3 ALL WIRE 20-GAUGE
- 4 WIRE PER MIL-W-5086

3392

Century IIB Autopilot - NAV Interface Wiring Diagram
Figure 5

AA-5 SERIES
MAINTENANCE MANUAL

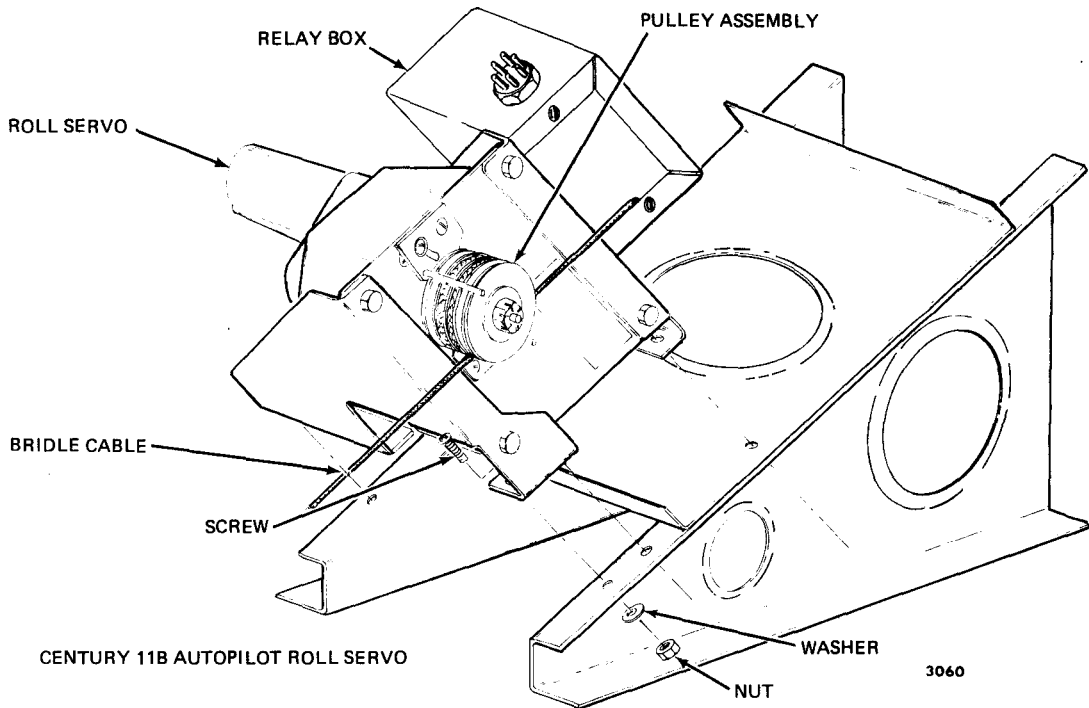
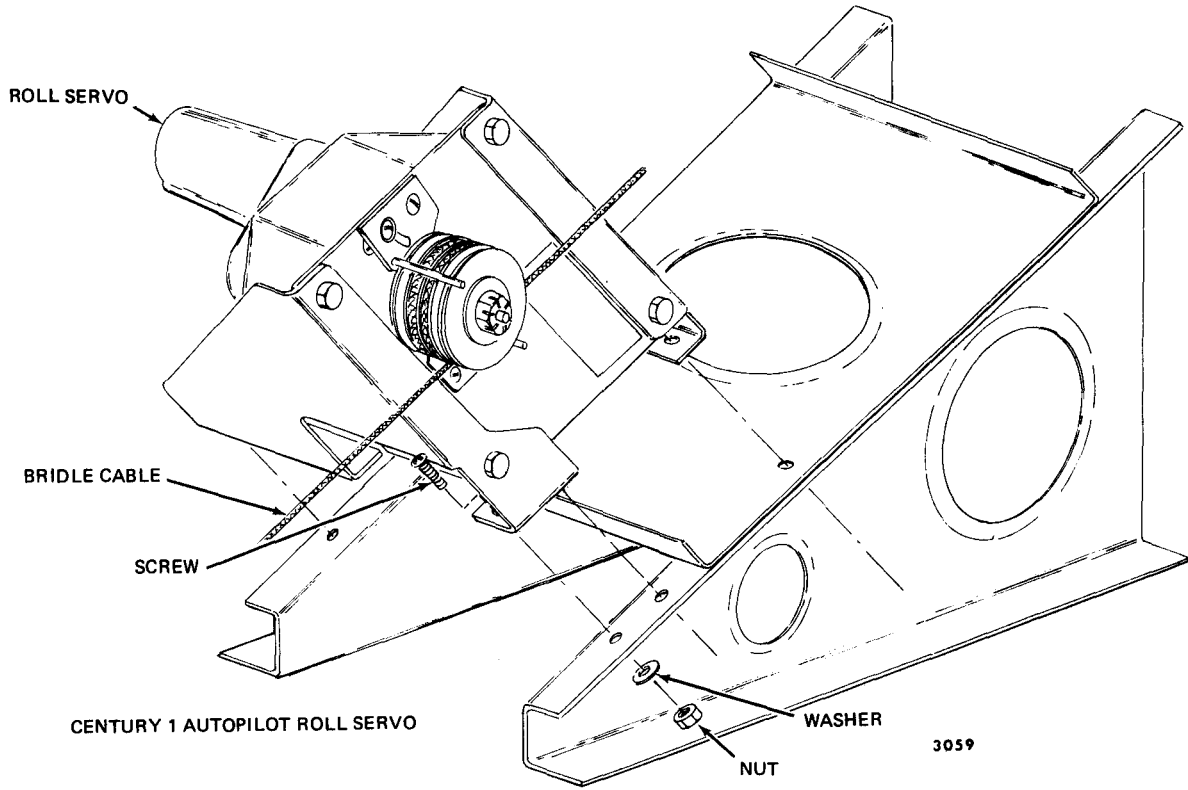

Roll Servo Removal - Installation
Figure 6

AUTOPILOT SYSTEM – MAINTENANCE PRACTICES

1. Roll Servo – Removal/Installation

A. Roll Servo – Removal (See Figure 6.)

- (1) Gain access to the cover end of the yoke support bracket by removing the Royalite pedestal side panels.
- (2) Loosen the cable guards on the servo and position away from capstan.
- (3) Loosen cable clamp bolts and remove from aileron cable.
- (4) Disconnect electrical connector from servo.
- (5) Remove attaching hardware and remove servo assembly from yoke support bracket.

B. Roll Servo – Installation (See Figure 6.)

- (1) Place servo assembly on the yoke support bracket and install attaching hardware.
- (2) Loosen the cable guards on the servo. Rotate the capstan so that the bridle cable pin hole is just forward of bottom cable guard, approximately 160 degrees from top cable guard. Position the bridle cable so that the long end of cable (from pin) is aft and parallel to the aileron cable. Insert the bridle cable pin into the capstan hole and tighten setscrews.

NOTE: Aileron cable should be clean and free from excessive oil or grease at points where cable clamp attachment is made.

- (3) With the aileron control in neutral position, wrap the short end of the bridle cable around the capstan 330 degrees. This will bring the cable forward. Attach the bridle cable to the aileron cable with one cable clamp.

NOTE: Move aileron control to the left stop (full travel). In this position the aft end of the forward cable clamp should clear the forward lower servo mount bolt by 1/8 inch to 1/4 inch. If this clearance is not provided, reposition cable clamps as necessary to provide clearance. Exercise aileron control, check for binding or other interference.

- (4) Wrap the long end of the bridle cable approximately 390 degrees aft around the capstan. Attach bridle cable to aileron cable using one cable clamp.
- (5) Torque cable clamp bolts to 55 ± 5 inch-pounds with a minimum of 0.005 inch measured between clamp halves after torquing. Cable tension should be the same as the aileron primary cable tension.
- (6) Position the cable guards within 1/32 inch of the capstan OD and tighten.
- (7) Rotate aileron through full travel and check for any binding or restriction of bridle cable or clamps that may contribute to unsafe conditions.

C. Adjust Cable Tension

- (1) Adjust aileron cable tension to 30 ± 2 pounds. Adjust bridle cable tension same as aileron cable $\pm 20\%$.
- (2) An alternate method of adjusting bridle cable tension is with aileron in neutral position, adjust bridle cable tension so that a pull of 10 ± 1 pound, using a calibrated spring scale attached at a point 1 inch aft of the forward cable clamp, will deflect the cable $3/8 \pm 1/16$ inch.

**AA-5 SERIES
MAINTENANCE MANUAL**

**CHAPTER 23
COMMUNICATIONS SYSTEMS**

TABLE OF CONTENTS

| <u>NUMBER</u> | | <u>PAGE</u> |
|----------------------|---|--------------------|
| 23-0 | COMMUNICATIONS SYSTEMS | |
| | Description/Operation | 1 |
| | General | 1 |
| | VHF Communications | 1 |
| | Audio Integrating System | 1 |
| | Emergency Locator Transmitter (ELT) System | 1 |
| 23-2-1 | NARCO VHF COMMUNICATION SYSTEM | |
| | Description/Operation | 1 |
| | General | 1 |
| | Operation | 1 |
| | Intercom Switch | 1 |
| | Troubleshooting | 101 |
| | General | 101 |
| | Maintenance Practices | 201 |
| | Removal and Installation | 201 |
| | Adjustment/Test | 202 |
| 23-2-2 | KING VHF COMMUNICATION SYSTEM | |
| | Description/Operation | 1 |
| | General | 1 |
| | Troubleshooting | 101 |
| | General | 101 |
| | Maintenance Practices | 201 |
| | Removal/Installation | 201 |
| | Adjustment/Test | 201 |
| 23-2-3 | COLLINS VHF COMMUNICATION SYSTEM | |
| | Description/Operation | 1 |
| | General | 1 |
| | Troubleshooting | 101 |

**AA-5 SERIES
MAINTENANCE MANUAL**

| <u>NUMBER</u> | <u>PAGE</u> |
|---|-------------|
| Maintenance Practices | 201 |
| Removal/Installation Test | 201 |
| 23-5-0 AUDIO INTEGRATING SYSTEM | |
| Description/Operation | 1 |
| General | 1 |
| Troubleshooting | 101 |
| Maintenance Practices | 201 |
| Removal/Installation | 201 |
| 23-5-1 NARCO CP-125/CP-135 AUDIO CONTROL PANEL | |
| Description/Operation | 1 |
| General | 1 |
| Audio Amplifier Switch | 1 |
| Troubleshooting | 101 |
| Maintenance Practices | 201 |
| Removal/Installation | 201 |
| Adjustment/Test | 201 |
| 23-5-2 KING KMA-20 AUDIO CONTROL PANEL | |
| Description/Operation | 1 |
| General | 1 |
| Troubleshooting | 101 |
| Maintenance Practices | 201 |
| Removal/Installation | 201 |
| Adjustment/Test | 201 |
| 23-5-3 COLLINS AMR-350 AUDIO CONTROL PANEL | |
| Description/Operation | 1 |
| General | 1 |
| Troubleshooting | 101 |
| Maintenance Practices | 201 |
| Removal/Installation | 201 |
| Test | 201 |

**AA-5 SERIES
MAINTENANCE MANUAL**

| <u>NUMBER</u> | | <u>PAGE</u> |
|---------------|--|-------------|
| 23-7-0 | NARCO ELT-10 () EMERGENCY LOCATOR TRANSMITTER (ELT) SYSTEM | |
| | Description/Operation | 1 |
| | General | 1 |
| | Troubleshooting | 101 |
| | Maintenance Practices | 201 |
| | Servicing | 201 |
| | Removal/Installation | 202 |
| | Adjustment/Test | 203 |

COMMUNICATIONS SYSTEMS - DESCRIPTION/OPERATION

1. General

The aircraft is delivered with customer ordered communications equipment installed. It contains one or two VHF communications radios, an optional Emergency Locator Transmitter, and for dual VHF or other navigation system equipped aircraft, an audio integrating system.

2. VHF Communications

Each aircraft is equipped with a VHF - band radio for voice communication. As an option a second radio can be installed. VHF radios operate in the 118.00 to 135.95 MHZ band, with the number of channels available either 360 or 720, depending upon the equipment installed.

3. Audio Integrating System

For those aircraft equipped with either dual VHF communications or various navigation systems, or both, an audio integrating system is necessary. An audio integrating panel permits the pilot to select which communication system to use, and permits the pilot to monitor signals from selected navigation system.

4. Emergency Locator Transmitter (ELT) System

An optional piece of equipment is the Emergency Locator Transmitter (ELT). The purpose of the ELT is to serve as a radio beacon, should the aircraft make an emergency or crash landing. The transmitter has automatic activation provisions should the aircraft strike an object with a force of 5 g's or more along the flight axis. The ELT can be used as a portable beacon should it be desired to leave the vicinity of the aircraft. It has its own antenna, battery pack, and a manual activating switch.

NARCO VHF COM SYSTEM — DESCRIPTION/OPERATION

1. General

The aircraft can be equipped with either a NARCO NAV 10/COM 10, COM 11, or COM 120 transceiver for voice communications. The transceiver operates within the frequency range of 118.00 MHz to 135.95 MHz, with a power output of 5 watts (COM 10 & 11), 8 watts (COM 10A & 11A). The transceiver can operate on any of 360/720 channels with a 50/25 KHz spacing between channels. Operation of the transceiver is controlled and monitored by the controls and indicators on the front panel of the transceiver. The navigation portion of the NAV 10/COM 10 system is discussed in Chapter 34. For a discussion of the switch and indicator functions, see Table 1. For location of transceiver components, see Figure 1.

2. Operation

The NARCO NAV 10/COM 10 transceiver can operate as a VHF radio or as a VHF navigation (OMNI) receiver (1 + 0 system). The mode of operation is controlled by the Mode Select Switch located on the front panel of the transceiver. This section discusses operation of the VHF radio portion, only.

The NARCO COM 11 is essentially the same as the COM 10, less the Mode Select Switch. The COM 11 is designed to be used exclusively as 360/720 channel transceiver. The NARCO COM 11 can be used with a NARCO NAV 11 or 12 to provide navigation, the pair would comprise a 1 + 1 system.

NOTE: NARCO COM 11B/111B has 720 channel (25 KHz spacing) capability.

The NARCO COM 120 operates within the frequency range of 118.000 MHz to 135.975 MHz, with a power output of 8 watts minimum (10 — 12) watts typical. The transceiver can operate on any of 720 independent channels, with 25 KHz between channels. The unit features 6 digit frequency readout, easy frequency tuning, and stable automatic squelch. See Table 2 for description of unit controls and indicators. This equipment available on 1978 model AA-5A and AA-5B.

3. Intercom Switch

An intercom switch is available as an optional item. The switch is installed on the instrument panel. The switch permits speech from the microphone to be heard over the speakers. It is essentially for training, allowing the operator to practice and learn microphone discipline. A yellow warning light is installed above the intercom switch. The light comes on when the switch is placed in the middle position. This is to remind the operator that the transmit function of the transceiver is disabled. The light is out with the switch in Speaker or Phone position. Use of the Intercom Switch requires the transceiver to be modified to the helicopter version. See the NARCO Maintenance Manual for further information.

TRANSCEIVER UNIT CONTROLS AND INDICATORS

Table 1

| Index No. (Fig. 1) | Control or Indicator | Position | Function |
|-----------------------|---|------------------|---|
| 1. | Mode Select Switch (NARCO COM 10 () only) | NAV | VHF Navigation mode selected, see Section 34. |
| | | COM | VHF Radio selected. |
| 2. | Squelch Control | | Establishes required input signal level to give an audio output from transceiver. |
| | | Clockwise | Required input signal level is decreased. |
| | | Counterclockwise | Required input signal level is increased. |
| 3. | Tenths/Hundreths Megahertz - Frequency Selector | | Selects frequency for radio in 50/25 KHZ steps. |
| 4. | Frequency Indicator | | Indicates operating frequency of radio. |
| 5. | Megahertz Frequency Selector | | Selects frequency in one (1) megahertz steps. |
| 6. | Power (Volume) Control | OFF (detent) | Removes power from system. |
| | | Clockwise | Increases audio volume. |
| | | Counterclockwise | Decreases audio volume. |
| 7. | IDENT (Part of Squelch Control) (NAV 10/COM () only) | Pulled | Allows station identification code to be heard. (Function is for VHF NAV Mode). |

**AA-5 SERIES
MAINTENANCE MANUAL**

**NARCO COM 120 TRANSCEIVER UNIT CONTROL AND INDICATORS
(1978 Model, AA-5A and AA-5B)**

TABLE 2

| Index No. (Fig. 1) | Control or Indicator | Function |
|-----------------------|--------------------------|--|
| 1. | Power ON/OFF/TEST | Applies power to unit. TEST — Automatic squelch disabled. |
| 2. | Volume | Controls audio volume. |
| 3. | Course Frequency Control | Changes transceiver frequency in one megahertz steps. |
| 4. | Fine Frequency Control | Changes transceiver frequency in 25 KHz steps. |
| 5. | Frequency Readout | Indicates operating frequency of transceiver. |
| 6. | Transmit Indicator Light | Illuminates when transceiver is transmitting. |

**AA-5 SERIES
MAINTENANCE MANUAL**

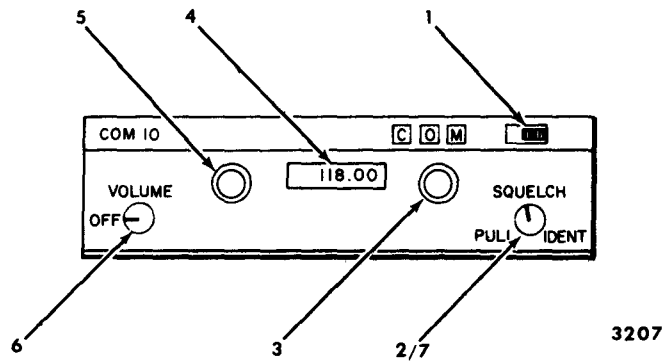

- | | |
|---|---------------------------------|
| 1. Mode Select Switch (NAV 10/COM 10 only) | 5. Megahertz Frequency Selector |
| 2. Squelch Control | 6. Power and Volume Control |
| 3. Tenths/Hundredths MHz Frequency Selector | 7. Ident (Squelch Pulled) |
| 4. Frequency Indicator | |

**AA-5 SERIES
MAINTENANCE MANUAL**

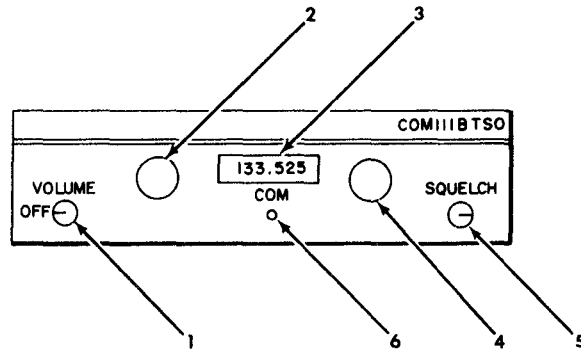

- | | |
|---------------------------------|---|
| 1. Volume Control | 4. Tenths/Hundredths Frequency Selector |
| 2. Megahertz Frequency Selector | 5. Power and Automatic Squelch |
| 3. Frequency Indicator | 6. Transmit Indicator Light |

NARCO COM 11/111 Transceiver
Figure 2 (Sheet 2 of 2)

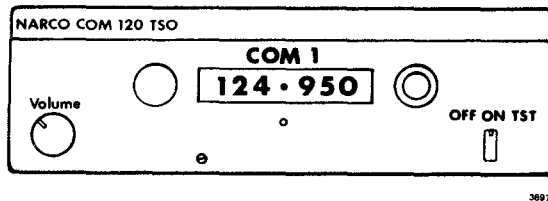

- | | |
|---|-----------------------------|
| 1. Power ON/OFF/TST (TST disables automatic squelch) | 4. Fine Frequency Selector |
| 2. Volume Control | 5. Frequency Readout |
| 3. Course Frequency | 6. Transmit Indicator Light |

NARCO COM 120 Transceiver
(1978 Model, AA-5A and AA-5B)
Figure 3 (Sheet 2 of 2)

TROUBLESHOOTING OF VHF (NARCO) COMMUNICATION SYSTEMS

1. General

System problems are sometimes caused by a malfunction of the transceiver. When possible replace the transceiver before proceeding with other troubleshooting.

NOTE: On those aircraft with dual systems, check operation of both transceivers. If neither transceiver works, the trouble is probably in the audio integrating system.

| TROUBLE | PROBABLE CAUSE | REMEDY |
|------------------------------|----------------------------------|---|
| No reception or transmission | Open circuit breaker | Close circuit or breaker. |
| | Dirty or corroded Antenna | Clean or replace antenna. |
| | Faulty audio panel (dual system) | Replace audio panel. |
| | Faulty transceiver | Replace transceiver. |
| Weak or No transmission | Faulty microphone | Replace microphone. (This may require an adjustment of Mike gain in the transceiver) |
| | Faulty antenna or antenna lead | Repair or replace antenna or wiring. |
| | Faulty transceiver | Replace transceiver. |
| Weak or No reception | Faulty speaker or headset | Replace speaker or headset. |
| | Faulty transceiver | Replace transceiver. |

VHF COMMUNICATION SYSTEM — MAINTENANCE PRACTICES

1. Removal and Installation of VHF Communication Components

NOTE: Figure 201 shows the top antenna as No. 1 VHF COM antenna and the bottom antenna as No. 2. This is true on aircraft equipped with a single COM NAV system. On aircraft with a dual COM NAV system installed, the No. 1 antenna is the bottom antenna and No. 2 is the top antenna.

A. Removal of VHF COM Antenna No. 1 (See Figure 201.)

- (1) Ensure the master switch is OFF.
- (2) Remove the three screws holding the antenna to the aircraft.
- (3) Lift the antenna straight up to gain access to the antenna connector. Disconnect the coax cable from the connector. Secure the cable so it will not slip through the hole and down into the aircraft.
- (4) Remove rubber gasket. If gasket adheres to the aircraft, remove it using a phenolic scraper.

B. Installation of VHF COM Antenna No. 1 (See Figure 201.)

- (1) Ensure the master switch is OFF.
- (2) Place the antenna rubber gasket in the proper position. (See Figure 201.)
- (3) Connect the antenna to the coaxial cable.
- (4) Place the antenna on the rubber gasket and install with three (3) screws.
- (5) Perform an operational check for the associated transceiver.

C. Removal and Installation of VHF COM Antenna No. 2 (External)

NOTE: The No. 2 VHF COM Antenna consists of two assemblies; the external tubular portion (antenna) and the internal impedance box assembly. If only the external part is to be replaced all that is required is to disconnect the tubular section from the outside of the aircraft and attach another. Ensure that the antenna is parallel with the centerline of the aircraft. (See Figure 201.)

D. Removal of Impedance Box for No. 2 VHF COM Antenna (See Figure 201.)

- (1) Ensure the master switch is OFF.
- (2) Obtain access to the impedance box by moving the rear seats and remove the proper portion of the floor.
- (3) Disconnect the coaxial cable from the impedance box.
- (4) On the outside of the aircraft disconnect VHF COM Antenna No. 2. Be careful not to damage.
- (5) With a phenolic scraper, remove as much as possible, the sealant from around the impedance box attaching nut.
- (6) Remove the attaching nut.
- (7) From inside the aircraft remove the impedance box.
- (8) Remove remaining sealant from around the antenna opening. Use aluminum wool.

E. Installation of Impedance Box for No. 2 VHF COM Antenna. (See Figure 201.)

- (1) Assure the master switch is OFF.
- (2) From inside the aircraft slip the impedance box down through the antenna opening.
- (3) From outside the aircraft install the impedance box attaching hardware, in proper sequence, and tighten.
- (4) Apply 3-M Company, EC-1128, sealant around attaching nut. Make sealant flush with the skin.

NOTE: An acceptable alternate is Presstite Engineering Company No. 579.6 sealer.

- (5) Attach No. 2 VHF COM Antenna. Assure that the antenna is parallel to the centerline of the aircraft.
- (6) From inside the aircraft connect the coaxial cable to the impedance box.
- (7) Replace any removed furnishing.
- (8) Perform an operational check for the associated transceiver.

F. Removal of the Transceiver Unit

- (1) Removal of the transceiver unit is straightforward.
- (2) Loosen transceiver from mounting case by turning locking (Allen) screw clockwise. Use 5/64 inch hex (Allen) wrench.
- (3) Slide the unit straight out to avoid bending the connector pins. A slight left to right movement may help in disconnecting unit from connector plug. Do not use the control knobs as handles. This may damage the associated control.

G. Installation of Transceiver Unit

- (1) Slide unit straight in. Be careful not to bend connector pins.
- (2) Secure unit to mounting case by turning locking (Allen) screw counterclockwise. Use 5/64 inch hex (Allen) wrench.

CAUTION: FOR AIRCRAFT WITH AUTOPILOT, MAKE SURE TRANSCEIVER HAS BEEN MODIFIED TO WORK WITH AUTOPILOT. AN UN-MODIFIED TRANSCEIVER WILL CAUSE ERRATIC AUTOPILOT OPERATION. SEE NARCO MANUAL 03088-600, SECTION 2. 8. 7.

NOTE: The mike gain of the transceiver is normally set for a NARCO low impedance microphone. If another type microphone is used, the mike gain control may require readjustment. See adjustment procedure in this section

2. Adjustment/Test NARCO Communication System

A. Mike Gain Adjustment

CAUTION: THE MINIMUM OF A 2ND CLASS F. C. C. LICENSE IS REQUIRED TO PERFORM THIS ADJUSTMENT.

AA-5 SERIES
MAINTENANCE MANUAL

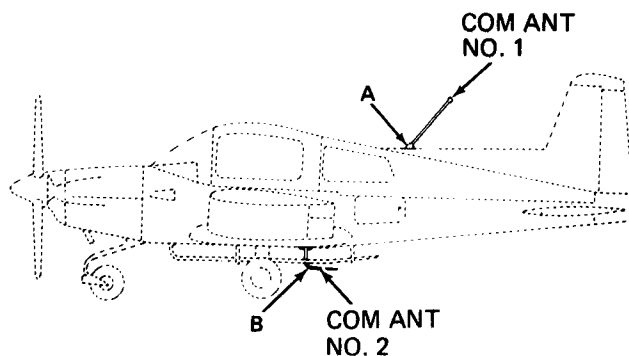
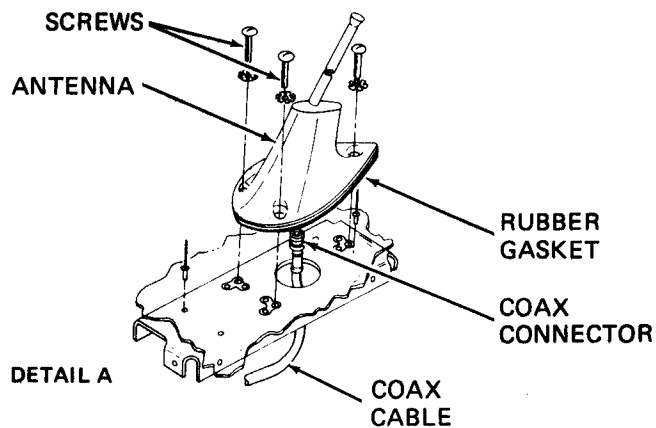

NOTE:
THIS IS NO. 2 COM NAV ANTENNA ON AIRCRAFT EQUIPPED WITH DUAL SYSTEM.

NOTE:
THIS IS NO. 1 COM NAV ANTENNA ON AIRCRAFT EQUIPPED WITH DUAL SYSTEMS.

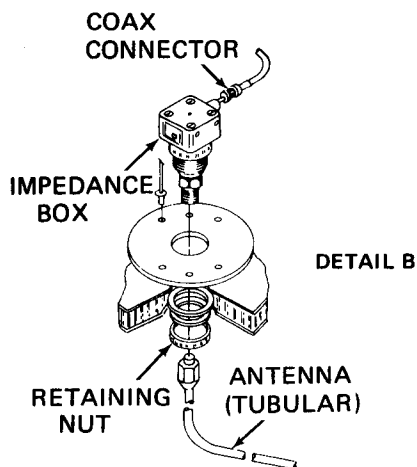

3215

VHF COM Antenna Installation
Figure 201

**AA-5 SERIES
MAINTENANCE MANUAL**

The transceiver is normally shop adjusted for use with a NARCO low impedance microphone. If another type of microphone is used, the MIKE GAIN control may require adjustment. It is necessary to remove the transceiver from the instrument panel to obtain access to the MIKE GAIN adjustment (See Figure 202). See NARCO Manual 03088-600, Section 3.4.2.6 or Section 4.4.5 for adjustment procedure.

After adjustment perform the operational check/test.

B. Test of NARCO COM System

NOTE: This procedure is for test of the communication portion of the set only. For the NAV portion (NAV 10/COM 10 ()), consult Section 34 of this manual.

NOTE: For aircraft with an intercom switch, set it to phone or speaker as desired.

NOTE: For aircraft with an audio control panel installed, assure that the panel is operating properly before proceeding with this checkout. See section 23-5-1. Set audio panel as desired.

NOTE: For aircraft equipped with Audio Amp switch the transceivers are modified so that they are activated when the Master switch is ON. Step 2 of the following procedure can be omitted when Audio Amp switch is installed. Place Audio Amp switch to desired position.

- (1) Assure the aircraft battery is installed and operating.
- (2) Assure the respective radio circuit breaker is closed.
- (3) Place MASTER switch to ON.
- (4) Set the mode select switch to COM. (NAV 10/COM 10 () units only).
- (5) Move the VOLUME control out of detent; turn clockwise to mid-position.
- (6) Rotate the SQUELCH control, in both directions. Assure the hissing noise decreases as the knob is rotated clockwise and increases with knob rotated counterclockwise. Then adjust the squelch as desired.
- (7) Set the frequency selectors to a tower frequency.
- (8) Contact the tower for a radio check. Adjust the volume as required. Contact the tower on several (up to five (5) if available) frequencies.
- (9) Place the ON/OFF volume control to OFF.
- (10) Place the Master switch to OFF.

C. Test of Intercom Switch

- (1) Assure the aircraft battery is installed and operating.
- (2) Place the Master switch to ON.
- (3) Place intercom switch to the "MIDDLE" position. Observe that yellow light, above switch, is illuminated.
- (4) Speak into the microphone. Voice of speaker should be heard over speakers.
- (5) Place intercom switch to "Speaker" position. Observe that the yellow light, above switch, is out.

**AA-5 SERIES
MAINTENANCE MANUAL**

- (6) Speak into the microphone. Speaker's voice is not heard over speakers.
- (7) Place intercom switch to "Phone" position. Indications are the same as Steps 5 and 6.
- (8) Place the MASTER switch to OFF.

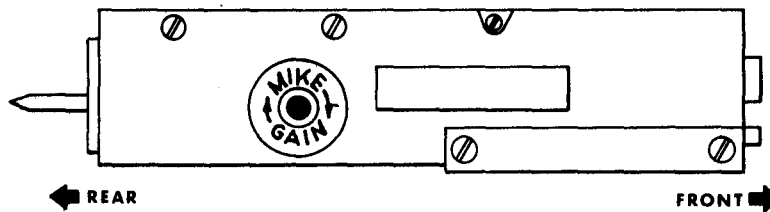

Location of MIKE GAIN Adjustment
Figure 202

KING VHF COMMUNICATION SYSTEM — DESCRIPTION/OPERATION

1. General

The KING KX-170/KX-175 () VHF radio consists of a panel mounted unit composing one-half of the KX-170/KX-175 () NAV-COM transceiver. This section discusses the COM portion only. The NAV portion is discussed in Chapter 34. The transceiver operates within the frequency range of 118.00 MHz to 135.95 MHz, with a power output of five (5) watts. The transceiver can operate on any of 360 (KX- 170A) or 720 (KX-170B/KX-175) channels with a 50 KHz or 25 KHz, respectively, spacing between channels. Operation is controlled and monitored by the switches and indicators on the front of the transceiver. For a discussion of switch and indicator functions, see Table 1. For location of system components, See Figure 1.

**AA-5 SERIES
MAINTENANCE MANUAL**

TRANSCEIVER UNIT CONTROLS AND INDICATORS

Table 1

| Index No. (Fig. 1) | Control or Indicator | Position | Function |
|-----------------------|---|-------------------|---|
| 1. | Frequency Indicator | | Indicates operating frequency of VHF radio. |
| 2. | Power Control Switch | OFF | Removes power from radio. |
| | | ON | Energizes the radio. |
| | | TEST | Disables automatic squelch. |
| 3. | Megahertz Frequency Selector | | Selects frequency in one (1) megahertz steps. |
| 4. | Tenths-Hundreths Megahertz Frequency Selector | | Selects frequency in 25 KHZ or 50 KHZ steps. |
| 5. | Volume Control | CLOCKWISE | Increases audio volume. |
| | | COUNTER-CLOCKWISE | Decreases audio volume. |

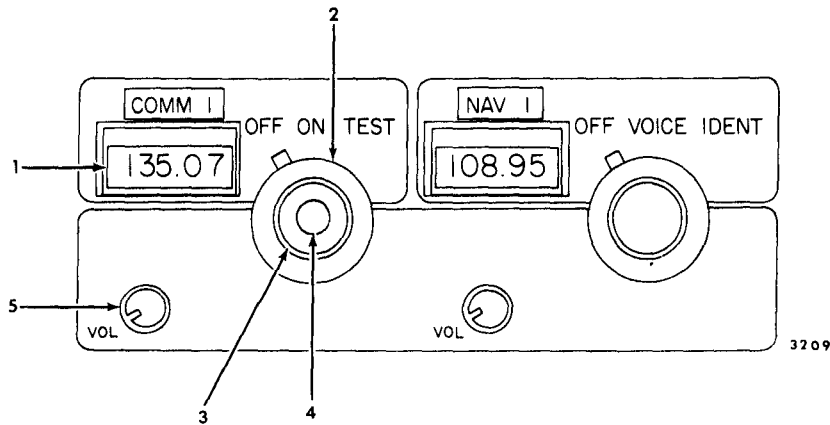

King KX-170 () Component Locations
Figure 1

**AA-5 SERIES
MAINTENANCE MANUAL**

TROUBLESHOOTING OF KING KX-170 () COM SYSTEM

1. General

System problems are sometimes caused by a malfunction of the transceiver. When possible replace the transceiver before proceeding with other troubleshooting.

NOTE: On those aircraft with dual systems, check operation of both transceivers. If neither transceiver works, the trouble is probably in the audio integrating system.

| TROUBLE | PROBABLE CAUSE | REMEDY |
|------------------------------|----------------------------------|---|
| No reception or transmission | Open circuit breaker | Close circuit breaker. |
| | Dirty or corroded antenna | Clean or replace antenna. |
| | Faulty audio panel (dual system) | Replace panel. |
| | Faulty transceiver | Replace transceiver. |
| Weak or No transmission | Faulty microphone | Replace microphone. (This may require an adjustment of MIKE GAIN in the transceiver.) |
| | Faulty antenna or antenna lead | Repair or replace antenna or wiring. |
| | Faulty transceiver | Replace transceiver. |
| Weak or No reception | Faulty speaker or headset | Replace speaker or headset. |
| | Faulty transceiver | Replace transceiver. |

KING COMMUNICATION SYSTEM — MAINTENANCE PRACTICES

1. Removal/Installation of KING Communication System Components

A. Antenna Removal and Installation. See Section 23-2-1, Page 201.

B. Removal of Transceiver Unit

- (1) Removal of the transceiver unit is straightforward.
- (2) Loosen transceiver from mounting case by turning locking (Allen) screw clockwise. Use 5/64 inch hex (Allen) wrench.
- (3) Slide the unit straight out. Be extremely careful not to bend connector pins. A slight left to right movement may help in disconnecting unit from connector plug.

NOTE: Do not use the control knobs as handles. This may damage the associated control.

C. Installation of Transceiver Unit

- (1) Slide the unit straight in. Be extremely careful not to bend connector pins.
- (2) Secure transceiver to mounting case by turning locking (Allen) screw counterclockwise. Use 5/64 inch hex (Allen) wrench.

NOTE: The MIKE GAIN of the transceiver is normally set for a KING low impedance microphone. If another type microphone is used, the MIKE GAIN control may require readjustment. See this Section for adjustment procedure.

2. Adjustment/Test KING Communication System

A. Mike Gain Adjustment KX-170/KX-175 () Transceiver

CAUTION: THE MINIMUM OF A 2ND CLASS F.C.C. LICENSE IS REQUIRED TO PERFORM THIS ADJUSTMENT.

The transceiver is normally shop adjusted for use with a King low impedance microphone. If another type of microphone is used, the MIKE GAIN control may require adjustment. It is necessary to remove the transceiver from the instrument panel to obtain access to the MIKE GAIN adjustment. See KING Maintenance Manual for adjustment procedure. After adjustment perform the operational check/test.

B. Test of KING 170/KX-175 () VHF COM System

NOTE: This procedure is for test of the communication portion of the set only. For the NAV portion, consult Section 34 this manual.

NOTE: For aircraft with an audio control panel installed, ensure that the panel is operating properly before proceeding with this checkout. See Section 23-5-2. Set the audio panel to the transceiver under test.

- (1) Ensure that the aircraft battery is installed and operating.
- (2) Ensure the respective radio circuit breaker is closed.
- (3) Place the MASTER switch to ON.
- (4) Rotate the VOLUME control fully clockwise.

**AA-5 SERIES
MAINTENANCE MANUAL**

- (5) Place the control switch to TEST. Assure that there is a hissing noise present. Place control switch to ON.
- (6) Set in a tower frequency.
- (7) Rotate the VOLUME control to mid-position. Contact the tower for a radio check.
- (8) Contact the tower on several (up to five (5) (KX-170A) or ten (10) (KX-170B) if available) frequencies from 118.00 to 135.95 MHZ.
- (9) Place the control switch to OFF.
- (10) Place the MASTER switch to OFF.

**AA-5 SERIES
MAINTENANCE MANUAL**

COLLINS VHF COMMUNICATION SYSTEM — DESCRIPTION/OPERATION

1. **General**

The COLLINS VHF-250 and VHF-251 transceivers operate within the frequency range of 118.000 MHz to 135.975 MHz, with a power output of 8 — 12 watts (10 watts nominal). The transceiver can operate on any of 720 independent channels, with 25 KHz spacing between channels. The VHF-251 differs from the VHF-250 in that it has the capability of storing and recalling a frequency without changing the frequency select controls. See Table 1 for description of unit controls and indicators. This equipment available on 1978 Model AA-5A and AA5B.

**AA-5 SERIES
MAINTENANCE MANUAL**

**COLLINS TRANSCEIVER UNIT CONTROLS AND INDICATORS
(1978 Model, AA-5A and AA-5B)**

TABLE 1

| Index No. Figure 1 & 2 | Control or Indicator | Position | Function |
|---------------------------|---|-----------------------------------|--|
| 1. | Frequency Indicator | | Indicates operating frequency of transceiver. |
| 2. | Store/Select/Recall Control (VHF-251 Only) | Select | Allows frequency controls to select operating frequency |
| | | Store | Stores in memory the frequency selected by select control. |
| | | Recall | Recall frequency stored in memory. |
| 3. | Transmit Indicator (VHF-251 Only) | | Illuminates when transceiver transmitting. |
| 4. | MHz Frequency Control | | Selects frequency in one megahertz steps. |
| 5. | KHz Frequency Control | | Selects frequency in 25 KHz steps. |
| 6. | ON/OFF VOL/SQUELCH TEST | ON | Power applied to unit. |
| | | OFF | Power removed from unit. |
| | | VOL Clockwise | Audio level increases. |
| | | VOL Counterclockwise | Audio level decreases. |
| | | Squelch Test (Knob Pulled Out) | Disables automatic squelch |

AA-5 SERIES
MAINTENANCE MANUAL

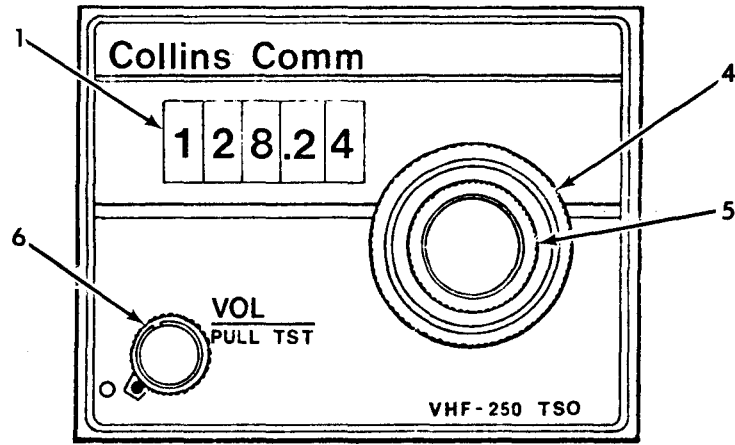

VHF-250 Transceiver
Figure 1

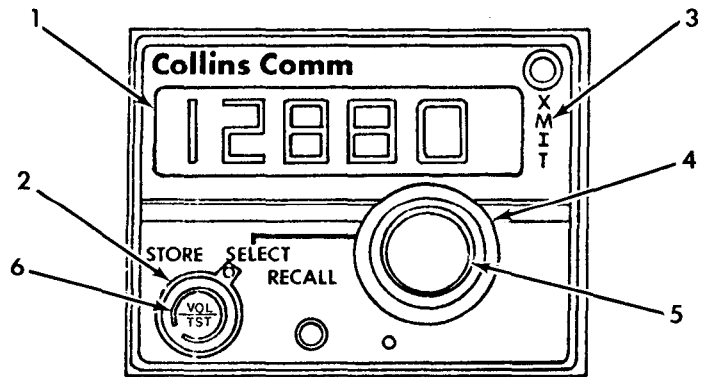

VHF-251 Transceiver
Figure 2

**AA-5 SERIES
MAINTENANCE MANUAL**

**TROUBLESHOOTING OF COLLINS VHF COMMUNICATIONS SYSTEMS
(1978 Model, AA-5A and AA5B)**

1. General

NOTE: On those aircraft with dual transceivers, check operation of both. If neither transceiver works, the trouble is probably in the audio integrating system.

| TROUBLE | PROBABLE CAUSE | REMEDY |
|-------------------------------|-----------------------------------|--|
| No reception or transmission. | Open circuit breaker. | Close circuit breaker. |
| | Dirty or corroded antenna. | Clean or replace antenna. |
| | Faulty audio panel (dual system). | Replace audio panel. |
| | Faulty transceiver. | Replace transceiver. |
| Weak or no transmission. | Faulty microphone. | Replace microphone (This may require an adjustment of mike gain in the transceiver.) |
| | Faulty antenna or antenna lead. | Repair or replace antenna or Wiring. |
| | Faulty transceiver. | Replace transceiver. |
| Weak or no reception | Faulty speaker or headset. | Replace speaker or headset. |
| | Faulty transceiver. | Replace transceiver. |

**AA-5 SERIES
MAINTENANCE MANUAL**

COLLINS VHF COMMUNICATION SYSTEM — MAINTENANCE PRACTICES

(1978 MODEL, AA-5A AND AA-5B)

1. Transceiver Removal/Installation

A. Removal of transceiver unit

- (1) Ensure DC power is removed from aircraft.
- (2) Loosen the transceiver from mounting case by turning locking screw counterclockwise. Use 5/64 inch hex wrench.
- (3) Slide the unit straight forward, avoid bending the connector pins. A slight left to right movement might help to release transceiver from connector plug.

NOTE: Do not use the front panel controls as handles. This may damage the associated control.

B. Installation of transceiver unit

- (1) Ensure DC power is removed from aircraft.
- (2) Slide transceiver straight in. Be careful not to bend connector pins.
- (3) Secure transceiver to mounting case by turning locking screw clockwise. Use 5/64 inch hex wrench.
- (4) Perform operational test of transceiver. (See test procedure in this chapter.)

NOTE: The mike gain of the transceiver is normally set for use with the same type (NARCO, KING, COLLINS) of microphone. If a different type microphone is used, the mike gain control may require adjustment.

2. Transceiver Test/adjustment

A. Transceiver operational test

- (1) Ensure the aircraft battery is installed and operational.
- (2) Place master switch to ON.
- (3) Place transceiver power control to ON.
- (4) Rotate volume control clockwise to midposition.
- (5) Disable automatic squelch by pulling VOL. control out. Receiver background noise should be heard.
- (6) Return VOL. control to normal position.
- (7) Tune the transceiver to a control tower frequency.
- (8) Contact the control tower for a radio check. Adjust the volume control as required. Contact the tower on several (up to five if available) frequencies.
- (9) Place transceiver power control to OFF.
- (10) Place master switch to OFF.

**AA-5 SERIES
MAINTENANCE MANUAL**

B. Transceiver microphone gain adjustment

CAUTION: THE MINIMUM OF A 2ND CLASS F.C.C. LICENSE IS REQUIRED TO PERFORM THIS ADJUSTMENT.

(1) Microphone gain adjustment

The transceiver microphone gain is normally shop adjusted for use with the same type microphone (NARCO, KING, COLLINS) as transceiver in use. If the microphone gain requires adjustment, refer to the maintenance manuals supplied by the manufacturer.

(2) Perform transceiver operational test after adjustment. (See Operational Test procedure in this chapter.)

**AA-5 SERIES
MAINTENANCE MANUAL**

AUDIO INTEGRATING SYSTEM – DESCRIPTION/OPERATION

1. General

The audio integrating system consists of the speakers, microphone, headsets, and an audio control panel. The audio control panel is an optional piece of equipment used on aircraft with dual VHF transceivers and/or multiple navigation systems such as VOR, ADF, or DME. The panel provides a central control point for the operation and monitoring of installed communication and navigation equipment. The speakers are mounted on the deck attached to the glareshield. The microphone is attached to the plugs into the center console. The headset plugs into a jack located in lower left corner of instrument panel. A microphone jack has been added to the instrument panel on 1978 and subsequent models.

**AA-5 SERIES
MAINTENANCE MANUAL**

TROUBLESHOOTING THE AUDIO INTEGRATING SYSTEM

NOTE: For those aircraft with an Audio Control panel installed, assure that the panel is operating properly before troubleshooting further.

| TROUBLE | PROBABLE CAUSE | REMEDY |
|---------------------------------|----------------------------|------------------------|
| Audio not available on speakers | Faulty speaker | Replace speaker. |
| | Faulty wiring | Repair wiring. |
| | Faulty transceiver | Replace transceiver. |
| | Faulty Audio Control Panel | Replace panel. |
| Audio not available on headset | Faulty headset | Replace headset. |
| | Faulty jack or wiring | Repair jack or wiring. |

AUDIO INTEGRATING SYSTEM - MAINTENANCE PRACTICES

1. Removal and Installation of System Components

A. Removal and installation of the microphone requires no special instructions.

NOTE: The microphone must be balanced to the transceiver installed. If a new microphone is installed the MIKE GAIN of the associated transceiver may require readjustment. See the applicable radio section in this chapter for instructions.

B. Removal of the Speakers

NOTE: Since the wiring is soldered to the speakers, the whole assembly is removed to facilitate maintenance.

- (1) Assure the MASTER switch is OFF.
- (2) Unscrew the seven fasteners attaching the deck to the glare shield.
- (3) Carefully lift up the deck to obtain access to the speakers. Remember the defrosters are attached to the deck.
- (4) Release the splices from the speaker leads to the aircraft wiring, on the pilot's side.
- (5) Unscrew the eight screws holding the speakers to the deck.
- (6) With the speakers away from aircraft, clip the leads from the defective speaker and remove.

C. Installation of the Speakers

- (1) Assure the MASTER switch is OFF.
- (2) Solder speaker to the wiring.
- (3) Attach the speakers to the deck (four screws each speaker) with the speaker leads on the pilot's speaker.
- (4) Attach the speaker leads to the aircraft wiring in accordance with the appropriate wiring diagram.
- (5) Attach the glareshield to the deck with the seven screws.
- (6) Perform a checkout of the speakers.

WARNING: BECAUSE OF THE EFFECT THE SPEAKER MAGNETS HAVE ON THE COMPASS, THE COMPASS WILL HAVE TO BE CALIBRATED. TO ACCOMPLISH THIS, PERFORM A COMPASS SWING.

- (7) Calibrate the compass.

**AA-5 SERIES
MAINTENANCE MANUAL**

NARCO CP-125/CP-135 AUDIO CONTROL PANEL -- DESCRIPTION/OPERATION

1. General

The NARCO CP-125/CP-135 audio control panel provides instant pushbutton selection of on-board navigation/communication avionics equipment. The panel is an optional piece of equipment used on aircraft with dual VHF transceivers and/or multiple navigation systems such as VOR, ADF, or DME. The panel provides a central control point for controlling and monitoring of installed communication and navigation equipment. For description and function of front panel controls, see Table 1. Location of controls are shown in Figures 1 and 3. The NARCO CP-135 is available on 1978 Model AA-5A and AA-5B.

NOTE: The CP-125 panel requires modifying if only one VHF Com radio is installed. See NARCO Maintenance Manual for the modification.

2. Audio Amplifier Switch (See Figure 2.)

NOTE: Used with CP-125 only.

An audio amplifier switch (Audio Amp) is installed on the instrument panel for those aircraft with two NARCO VHF transceivers installed. The installation of this switch plus the modification of the transceivers allow the AUDIO AMPLIFIER of the transceiver to function when the Master switch is placed in the "ON" position, regardless of the position of the transceiver ON/OFF control or the position of the selector switches on the CP-125 Audio Control panel. This provides a safety feature in case the audio amplifier fails in one of the transceivers.

AUDIO PANEL CONTROLS

Table 1

| Index No. (Fig. 1) | Control | Position | Function |
|--|------------------|----------------|--|
| 1. | COM 1 Control | Depressed (in) | Selects No. 1 VHF transmitter and receiver. Deselects No. 2 VHF radio. |
| | | Out | Deselects No. 1 COM. |
| 2. | COM 2 Control | Depressed (in) | Selects No. 2 VHF transmitter and receiver. Deselects No. 1 VHF radio. |
| | | Out | Deselects No. 2 COM. |
| <p><u>NOTE:</u> COM 1 and COM 2 Controls are interlocked, both cannot be depressed at the same time.</p> | | | |
| 3. | Both COM Control | Depressed (in) | Permits simultaneous monitoring of audio from both VHF COM receivers. |
| | | Out | Audio monitoring of VHF radios is selected by COM 1 or COM 2 controls. |
| 4. | NAV 1 Control | Depressed (in) | Permits monitoring of audio signals from No. 1 NAV System in headset or speaker. |
| | | Out | Audio monitoring of No. 1 NAV is not available. |
| 5. | NAV 2 Control | Depressed (in) | Permits monitoring of audio signals from No. 2 NAV System in headset or speaker. |
| | | Out | Audio monitoring of No. 2 NAV is not available. |

AUDIO PANEL CONTROLS (Continued)

Table 1 (Continued)

| Index No. (Fig. 1) | Control | Position | Function |
|-----------------------|------------------------|----------------|---|
| 6. | ADF Control | Depressed (in) | Permits monitoring of audio signals from the ADF. |
| | | Out | Audio Monitoring of the ADF is not available. |
| 7. | MKR OR MKR DME Control | Depressed (in) | Permits monitoring of Marker Beacon audio. On those aircraft with DME, audio monitoring of DME is also available. |
| | | Out | Audio monitoring of the Marker Beacon and DME, if installed, is not available. |
| 8. | SPKR Control | Depressed (in) | Audio from selected system or systems is transferred to the speakers and headset. |
| | | Out | Audio monitoring of the selected system is available on the headset only. |

AA-5 SERIES
MAINTENANCE MANUAL

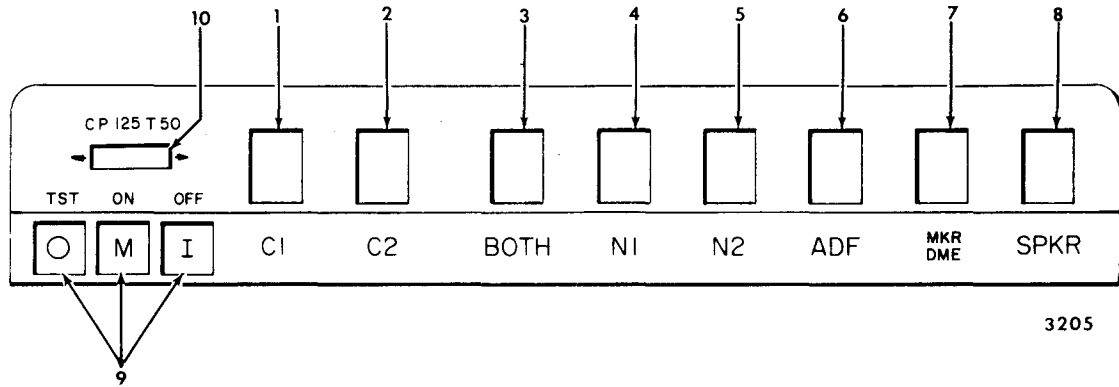

- | | |
|--------------------------|----------------------------|
| 1. COM 1 Control | 8. Speaker Control |
| 2. COM 2 Control | 9. Marker Beacon Indicator |
| 3. Both COM Control | O-Outer |
| 4. NAV 1 Control | M-Middle |
| 5. NAV 2 Control | I-Inner |
| 6. ADF Control | 10. Power Control |
| 7. Marker or DME Control | |

NARCO CP-125 Audio Control Panel
Figure 1

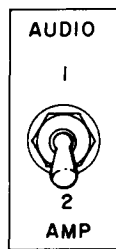

3359

Audio Amplifier Switch
Figure 2

AA-5 SERIES
MAINTENANCE MANUAL

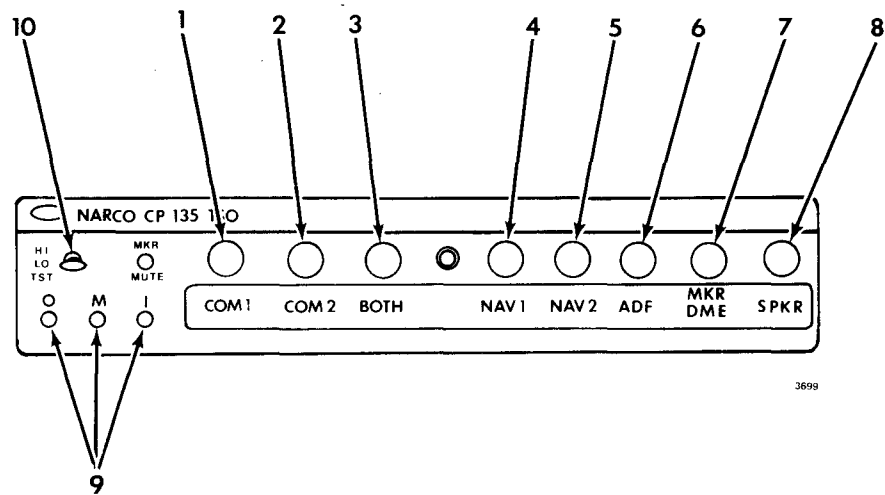

- | | |
|---------------------|---|
| 1. COM 1 Control | 7. Marker or DME Control |
| 2. COM 2 Control | 8. Speaker Control |
| 3. Both COM Control | 9. Marker Beacon Indicator |
| 4. NAV 1 Control | O - Outer |
| 5. NAV 2 Control | M - Middle |
| 6. ADF Control | I - Inner |
| | 10. Marker Receiver Sensitivity Control |

NARCO CP-135, Audio Panel
(1978 Model, AA-5A and AA-5B)
Figure 3

TROUBLESHOOTING THE AUDIO INTEGRATING SYSTEM

| TROUBLE | PROBABLE CAUSE | REMEDY |
|---|---------------------------------------|--|
| One Communication or Navigation System appears inoperative. | Faulty audio panel. Faulty System. | Replace panel. Troubleshoot system. |
| System audio not available on the speakers. | Faulty speaker. | Replace speaker. |
| | Faulty audio panel. | Replace panel. |
| | Faulty wiring to speaker. | Repair wiring. |
| System audio not available at the headset. | Faulty headset. | Replace headset. |
| | Faulty jack. | Replace jack. |
| | Faulty audio panel. | Replace panel. |
| | Faulty wiring to jack. | Repair wiring. |
| System audio available but no transmission. | Faulty microphone. | Replace microphone. (This may require a readjustment of MIKE GAIN in transceiver.) See transceiver section in this chapter for instructions. |
| | Faulty microphone jack. | Replace jack. |
| | Faulty wiring to Mike jack. | Replace wiring. |
| | Faulty transceiver. | Replace transceiver. |
| | Faulty audio control panel. | Replace control panel. |

NARCO CP-125/CP-135 AUDIO CONTROL PANEL — MAINTENANCE PRACTICES

1. Removal and Installation of CP-125/CP-135 Audio Control Panel

NOTE: CP-135 available on 1978 Model AA-5A and AA-5B.

The removal and installation of the CP-125/CP-135 Audio Control Panel is simple and requires no special instructions. Use 5/64 inch hex wrench to release unit from instrument panel. Slide unit straight out and in. Be careful not to damage connector pins.

2. Test of NARCO CP-125/CP-135 Audio Control Panel

A. Test

NOTE: This procedure assumes normal operation of communication and navigation equipment installed in the aircraft. Ensure that these systems are operating properly before proceeding.

- (1) Ensure the aircraft battery is installed and operating.
- (2) Place the MASTER switch to ON.
- (3) Place Audio Amp switch to 1 (CP-125 only).
- (4) If two communication systems are available, tune each to a different operating frequency. Plug the headset into the jack. Plug the microphone in.
- (5) Ensure that the SPKR button is out.
- (6) For aircraft with Intercom switch, place to phone (CP-125 only).
- (7) Press the COM 1 button. Check that COM 1 audio is available in the headphones. Adjust SQUELCH control on transceiver if necessary.
- (8) Place Intercom switch to Speaker (CP-125 only).
- (9) Press the SPKR button. Check that COM 1 audio is available on the speakers. then push out the SPKR button, and place intercom switch to phone (CP-125 only).
- (10) Press the COM 2 button. Check that COM 2 audio is available in the headphones. Adjust SQUELCH control on transceiver if necessary.
- (11) Place Intercom switch to speaker (CP-125 only). Press the SPKR button. COM 2 audio is available on the speakers.
- (12) Place Intercom switch to phone (CP-125 only).
- (13) Press the BOTH COM button. Both systems are heard on the headphones (rotate SQUELCH control if necessary).
- (14) Place Intercom switch to Speaker (CP-125 only).
- (15) Press the SPKR button. Check that both systems can be heard over the speakers. Push the SPKR button out.
- (16) Place Intercom switch to phone (CP-125 only).
- (17) During the following checks, place the Audio Amp switch to 2 (CP-125 only). There should be little or no difference in audio reception.

AA-5 SERIES
MAINTENANCE MANUAL

- (18) In turn, test the following as applicable: VHF NAV No. 1, VHF NAV No. 2, ADF, DME Marker Beacon. In each case check both headphone and SPKR operation.

NOTE: In order to check Marker Beacon operation it is necessary to perform a flight test over a beacon. If available, a beacon ramp generator can be used, avoiding a flight check.

- (19) Turn OFF all of the radios and navigation systems.
- (20) Place Master switch to OFF.

KING KMA-20 AUDIO CONTROL PANEL - DESCRIPTION/OPERATION

1. General

The King KMA-20 audio control panel provides instant and central control of all onboard navigation// communication equipment. The audio panel is an optional piece of equipment used on aircraft with dual communication systems and/or multiple navigation systems such as VOR, ADF, DME. The panel permits monitoring of audio signals from the radio navigation systems and also permits selection of the desired communication system on those aircraft with dual systems. The panel also controls the marker beacon system. See Section 34 for a discussion of the system. For a discussion of the functions of the various system switches, see Table 1. Locations of various components are shown in Figure 1.

AUDIO PANEL CONTROLS

Table 1

| Index No. (Fig. 1) | Control | Position | Function |
|-----------------------|----------------------|--------------|---|
| 1. | Microphone selector | COM-1 | Selects No. 1 communication system transmission and reception. |
| | | COM-2 | Selects No. 2 communication system transmission and reception. |
| | | EXT | (NOT USED) |
| 2. | Auto selector | SPEAKERS | Audio from the system selected by the Microphone selector (1) is routed to the speaker. |
| | | Center (OFF) | Audio is controlled by switches (3) and (4). |
| | | PHONE | Audio is routed to the headphones. |
| 3. | COM-1 Audio selector | SPEAKERS | Audio from the No. 1 communication system is sent to the speakers. |
| | | Center (OFF) | Audio routing is controlled by the AUTO selector. |
| | | PHONE | No. 1 system audio is sent to the headphones. |
| 4. | COM-2 Audio selector | SPEAKERS | Audio from the No. 2 communication system is sent to the speakers. |
| | | Center (OFF) | Audio routing is controlled by the AUTO selector. |
| | | PHONE | No. 2 system audio is sent to the headphones. |
| 5. | NAV-1 Audio selector | SPEAKERS | Audio from the No. 1 NAV is sent to the speakers. |
| | | Center (OFF) | Audio from the No. 1 NAV system is not available. |
| | | PHONE | Audio from the No. 1 NAV is sent to the headphones. |
| 6. | NAV-2 Audio selector | SPEAKERS | Audio from the No. 2 NAV is sent to the speakers. |

AUDIO PANEL CONTROLS

Table 1

| Index No. (Fig. 1) | Control | Position | Function |
|-----------------------|--------------------|--------------|---|
| | | Center (OFF) | Audio from the No. 2 NAV system is not available. |
| | | PHONE | Audio from the No. 2 NAV is sent to the headphones. |
| 7. | ADE Audio Selector | SPEAKERS | Audio from the ADF system is sent to the speakers. |
| | | Center (OFF) | Audio from the ADF is not available. |
| | | PHONE | Audio from the ADF is routed to the headphones. |
| 8. | DME Audio Selector | SPEAKERS | Ident audio from the DME is sent to the speakers. |
| | | Center (OFF) | Audio from the DME is not available. |
| | | PHONE | Audio from the DME is sent to the headphones. |
| 9. | MKR Audio Selector | SPEAKERS | Audio from the Marker Beacon is sent to the speakers. |
| | | Center (OFF) | Audio from the Marker Beacon is not available. |
| | | PHONE | Audio from the Marker Beacon is sent to the headphones. |

AA-5 SERIES
MAINTENANCE MANUAL

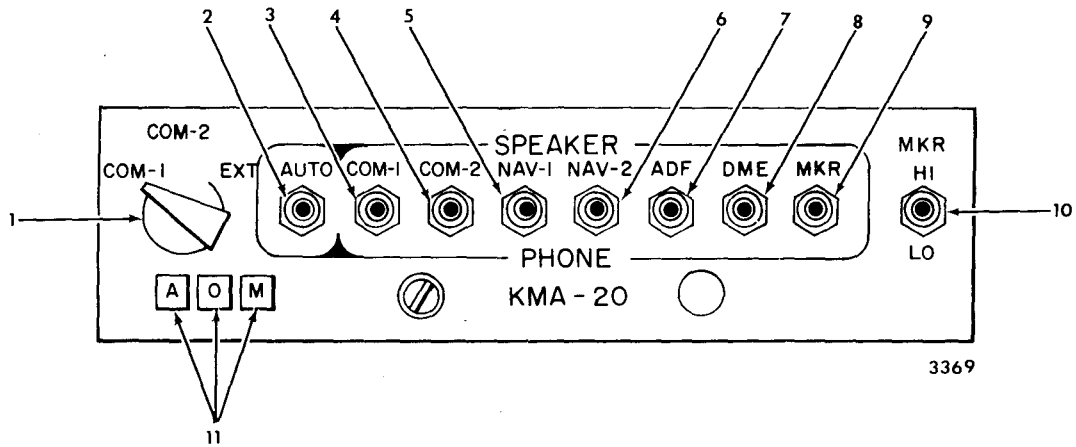

- | | |
|------------------------------|--|
| 1. Microphone Input Selector | 8. DME Selector |
| 2. Auto Selector | 9. Marker Beacon Selector |
| 3. COM 1 Selector | 10. Marker Beacon Sensitivity Selector |
| 4. COM 2 Selector | 11. Marker Beacon Indicator |
| 5. NAV 1 Selector | A-Inner |
| 6. NAV 2 Selector | O-Outer |
| 7. ADF Selector | M-Middle |

NOTE: Switches 2-10 are toggle switches.

King KMA-20 Audio Control Panel
Figure 1

TROUBLESHOOTING THE KING KMA-20 AUDIO CONTROL PANEL

| TROUBLE | PROBABLE CAUSE | REMEDY |
|---|----------------------------|---|
| One Communication or Navigation System appears inoperative. | Faulty audio panel | Replace panel. |
| | Faulty system | Troubleshoot system. |
| System audio not available on the speakers or headset. | Faulty audio panel | Replace panel. |
| System audio available but no transmission. | Faulty microphone | Replace microphone. (This may require a re-adjustment of MIKE GAIN in transceiver. See transceiver section in this Chapter for instructions.) |
| | Faulty Mike jack | Replace jack. |
| | Faulty wiring to Mike jack | Repair wiring. |
| | Faulty transceiver | Replace transceiver. |
| | Faulty Audio Control panel | Replace control panel. |

KING KMA-20 AUDIO CONTROL PANEL - MAINTENANCE PRACTICES

1. Removal and Installation of KMA-20 Audio Control Panel

A. The removal and installation of the KMA-20 Audio Control Panel is simple and requires no special instructions. Release and secure unit to mounting case by turning allen screw that locks unit to mounting case. Use 5/64 allen wrench. Slide unit straight out and in. Be careful not to damage connector pins.

B. Test of King KMA-20 Audio Control Panel

NOTE: This procedure assumes normal operation of the communication and navigation equipment installed in the aircraft. Assure that these systems are operating properly before proceeding.

- (1) Assure the aircraft battery is installed and operating.
- (2) Assure all RADIO circuit breakers are closed.
- (3) Place the MASTER switch to ON.
- (4) If two communication systems are installed, tune each to a different operating frequency. Plug the microphone and headset into the appropriate jacks.
- (5) Set all toggle switches to mid-position.
- (6) Set microphone selector to COM-1.
- (7) Set Auto selector to Speaker.
- (8) Contact the tower on the No. 1 VHF communication system. Tower reply should be heard on speaker.
- (9) Place the microphone selector to COM-2. Repeat step (8) using the No. 2 VHF Communication system.
- (10) Repeat steps (6) (8) and (9) with the AUTO switch in Phone. The COM audio is heard on the headphone.
- (11) Return the AUTO switch to OFF. Place COM-1 switch to SPEAKER and then PHONE. Check that the COM-1 audio is in turn available on the speakers and then headphones.
- (12) Test the following: NAV-1, NAV-2, ADF, DME, and MKR (Marker Beacon). In each case, check both SPEAKER and PHONE operation.

NOTE: In order to check Marker Beacon operation it is necessary to perform a flight test over a beacon. If available, a beacon ramp generator can be used, avoiding the check flight.
- (13) Turn off all of the radios and navigation systems.
- (14) Place the MASTER switch to OFF.

**AA-5 SERIES
MAINTENANCE MANUAL**

COLLINS AMR-350 AUDIO CONTROL PANEL — DESCRIPTION/OPERATION

1. General

The COLLINS AMR-350 audio control panel provides instant and central control of all onboard navigation/communication equipment. The installation of the audio control is optional and is used on aircraft with dual communication systems and/or multiple navigation systems such as VOR, ADF, or DME. The panel permits monitoring of audio signals from the radio navigation systems and also permits selection of the desired communication system on those aircraft with dual systems. See Table 1 for description of control switches. The COLLINS AMR-350 is available on 1978 Model AA-5A and AA-5B.

**AA-5 SERIES
MAINTENANCE MANUAL**

AUDIO PANEL CONTROLS

Table 1

| Index No. (Fig. 1) | Control | Position | Function |
|-----------------------|-------------------------------|--------------|--|
| 1. | Communication system selector | COM-1 | Selects No. 1 communication system transmission and reception. |
| | | COM-2 | Selects No. 2 communication system transmission and reception. |
| | | EXT | (NOT USED) |
| 2. | Auto selector | SPEAKERS | Audio from the system selected by the communication selector (1) is routed to the speaker. |
| | | Center (OFF) | Audio is controlled by switches (3) and (4). |
| | | PHONE | Audio is routed to the headphones. |
| 3. | COM-1 Audio selector | SPEAKERS | Audio from the No. 1 Communication system is sent to the speakers. |
| | | Center (OFF) | Audio routing is controlled by the AUTO selector. |
| | | PHONE | No. 1 system audio is sent to the headphones. |
| 4. | COM-2 Audio selector | SPEAKERS | Audio from the No. 2 communication system is sent to the speakers. |
| | | Center (OFF) | Audio routing is controlled by the AUTO selector. |
| | | PHONE | No. 2 system audio is sent to the headphones. |
| 5. | NAV-1 Audio selector | SPEAKERS | Audio from the No. 1 NAV is sent to the speakers. |
| | | Center (OFF) | Audio from the No. 1 NAV system is not available. |
| | | PHONE | Audio from the No. 1 NAV is sent to the headphones. |
| 6. | NAV-2 Audio selector | SPEAKERS | Audio from the No. 2 NAV is sent to the speakers. |

**AA-5 SERIES
MAINTENANCE MANUAL**

AUDIO PANEL CONTROLS

Table 1

| Index No. (Fig. 1) | Control | Position | Function |
|-------------------------------|------------------------------------|---------------------|--|
| | | Center (OFF) | Audio from the No. 2 NAV system is not available. |
| | | PHONE | Audio from the No. 2 NAV is sent to the headphones. |
| 7. | ADF Audio Selector | SPEAKERS | Audio from the ADF system is sent to the speakers. |
| | | Center (OFF) | Audio from the ADF is not available. |
| | | PHONE | Audio from the ADF is routed to the headphones. |
| 8. | DME Audio Selector | SPEAKERS | Ident audio from the DME is sent to the speakers. |
| | | Center (OFF) | Audio from the DME is not available. |
| | | PHONE | Audio from the DME is sent to the headphones. |
| 9. | MKR Audio Selector | SPEAKERS | Audio from the Marker Beacon is sent to the speakers. |
| | | Center (OFF) | Audio from the MARKER Beacon is not available. |
| | | PHONE | Audio from the Marker Beacon is sent to the headphones. |
| 10. | Marker Receiver Sensitivity | HIGH | High receiver sensitivity. |
| | | LOW | Low receiver sensitivity. |
| | | TEST | Test marker lights. |

**AA-5 SERIES
MAINTENANCE MANUAL**

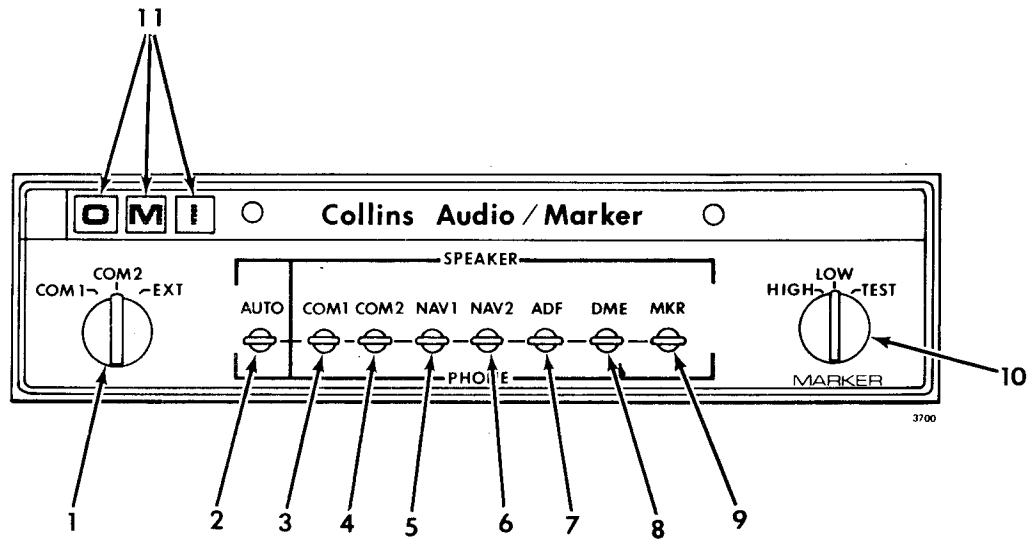

- | | |
|----------------------------|---------------------------------|
| 1. COM 1/COM 2/EXT Control | 7. ADF Control |
| 2. AUTO Control | 8. DME Control |
| 3. COM 1 Control | 9. MKR Control |
| 4. COM 2 Control | 10. MARKER HIGH/LOW/TEST Select |
| 5. NAV 1 Control | 11. Marker Light |
| 6. NAV 2 Control | O - Outer |
| | M - Middle |
| | I - Inner |

Collins AMR- 350 Audio/Marker Panel
(1978 Model, AA-5A and AA-5B)
Figure 1

**AA-5 SERIES
MAINTENANCE MANUAL**

TROUBLESHOOTING THE COLLINS AMR-350 AUDIO CONTROL PANEL

(1978 MODEL, AA-5A AND AA-5B)

| TROUBLE | PROBABLE CAUSE | REMEDY |
|---|-----------------------------|--|
| One Communication or Navigation System appears inoperative. | Faulty audio panel. | Replace panel. |
| | Faulty system. | Troubleshoot system. |
| System audio not available on the speakers or headset. | Faulty audio panel | Replace panel. |
| System audio available but no transmission | Faulty microphone. | Replace microphone. (This may require a readjustment of MIKE GAIN in transceiver. See transceiver section in this Chapter for instructions.) |
| | Faulty Mike jack. | Replace jack. |
| | Faulty wiring to Mike jack. | Repair wiring. |
| | Faulty transceiver. | Replace transceiver. |
| | Faulty Audio Control panel. | Replace control panel. |

**AA-5 SERIES
MAINTENANCE MANUAL**

COLLINS AMR-350 AUDIO CONTROL PANEL — MAINTENANCE PRACTICES

(1978 MODEL, AA-5A AND AA-5B)

1. Removal and Installation of AMR- 350 Audio Control Panel

- A. The removal and installation of the AMR-350 Audio Control Panel is simple and requires no special instructions. Release and secure unit to mounting case by turning allen screw that locks unit to mounting case. Use 5/64 allen wrench. Slide unit straight out and in. Be careful not to damage connector pins.
- B. Test of COLLINS AMR-350 Audio Control Panel

NOTE: This procedure assumes normal operation of the communication and navigation equipment installed in the aircraft. Ensure that these systems are operating properly before proceeding.

- (1) Ensure the aircraft battery is installed and operating.
- (2) Ensure all RADIO circuit breakers are closed.
- (3) Place the MASTER switch to ON.
- (4) If two communication systems are installed, tune each to a different operating frequency. Plug the microphone and headset into the appropriate jacks.
- (5) Set all toggle switches to mid-position.
- (6) Set communication selector to COM-1.
- (7) Set Auto selector to Speaker.
- (8) Contact the tower on the No. 1 VHF communication system. Tower reply should be heard on speaker.
- (9) Place the communication selector to COM-2. Repeat Step (8) using the No. 2 VHF Communication system.
- (10) Repeat Steps (5), (8), and (9) with the AUTO switch in Phone. The COM audio is heard on the head-phone.
- (11) Return the AUTO switch to OFF. Place COM-1 switch to SPEAKER and then PHONE. Check that the COM-1 audio is in turn available on the speakers and then headphones.
- (12) Test the following: NAV-1, NAV-2, ADF, DME, and MKR (Marker Beacon). In each case, check both SPEAKER and PHONE operation.

NOTE: In order to check Marker Beacon operation, it is necessary to perform a flight test over a beacon. If available a beacon ramp generator can be used, avoiding the check flight.
- (13) Turn off all of the radios and navigation systems.
- (14) Place the MASTER switch to OFF.

AA-5 SERIES
MAINTENANCE MANUAL

NARCO ELT-10 EMERGENCY LOCATOR TRANSMITTER (ELT) SYSTEM — DESCRIPTION/OPERATION

1. General

The emergency locator transmitter (ELT) is a self-contained, battery-powered radio transmitter which emits a signal (121.5/243.0 MHz) to assist in locating a downed aircraft. The ELT System consists of a transmitter located in the aft fuselage section under the vertical stabilizer and a transmitting antenna mounted on the turtleback, protruding through the dorsal fin. The ELT is activated automatically by a deceleration of 5g's along the flight axis of the aircraft. It can also be activated manually by removing the left side empennage inspection cover and moving the transmitter control switch to the ON position. For location of controls, see Figure 1. Table 1 contains a list of switch positions and functions. If it is required to leave the area of the aircraft, the ELT unit can be removed and hand carried. In this condition, extend the built-in antenna and place control switch to ON.

AA5A/AA5B 1978 and subsequent models

ELT can be activated by a remote control switch located on the instrument panel. The remote switch is wired in parallel with the ON-OFF-ARM switch on the ELT unit. (See Figure 101).

**AA-5 SERIES
MAINTENANCE MANUAL**

TROUBLESHOOTING OF THE ELT-10 EMERGENCY LOCATOR TRANSMITTER

| TROUBLE | PROBABLE CAUSE | REMEDY |
|-------------------|-------------------------------------|--|
| No transmission | Faulty transmitter | Replace transmitter. |
| | Faulty wiring to antenna | Repair wiring. |
| | Faulty battery | Replace battery pack. |
| Weak transmission | Faulty antenna or wiring to antenna | Replace antenna assembly. Repair wiring. |
| | Faulty transmitter | Replace transmitter. |
| | Faulty battery | Replace battery pack. |

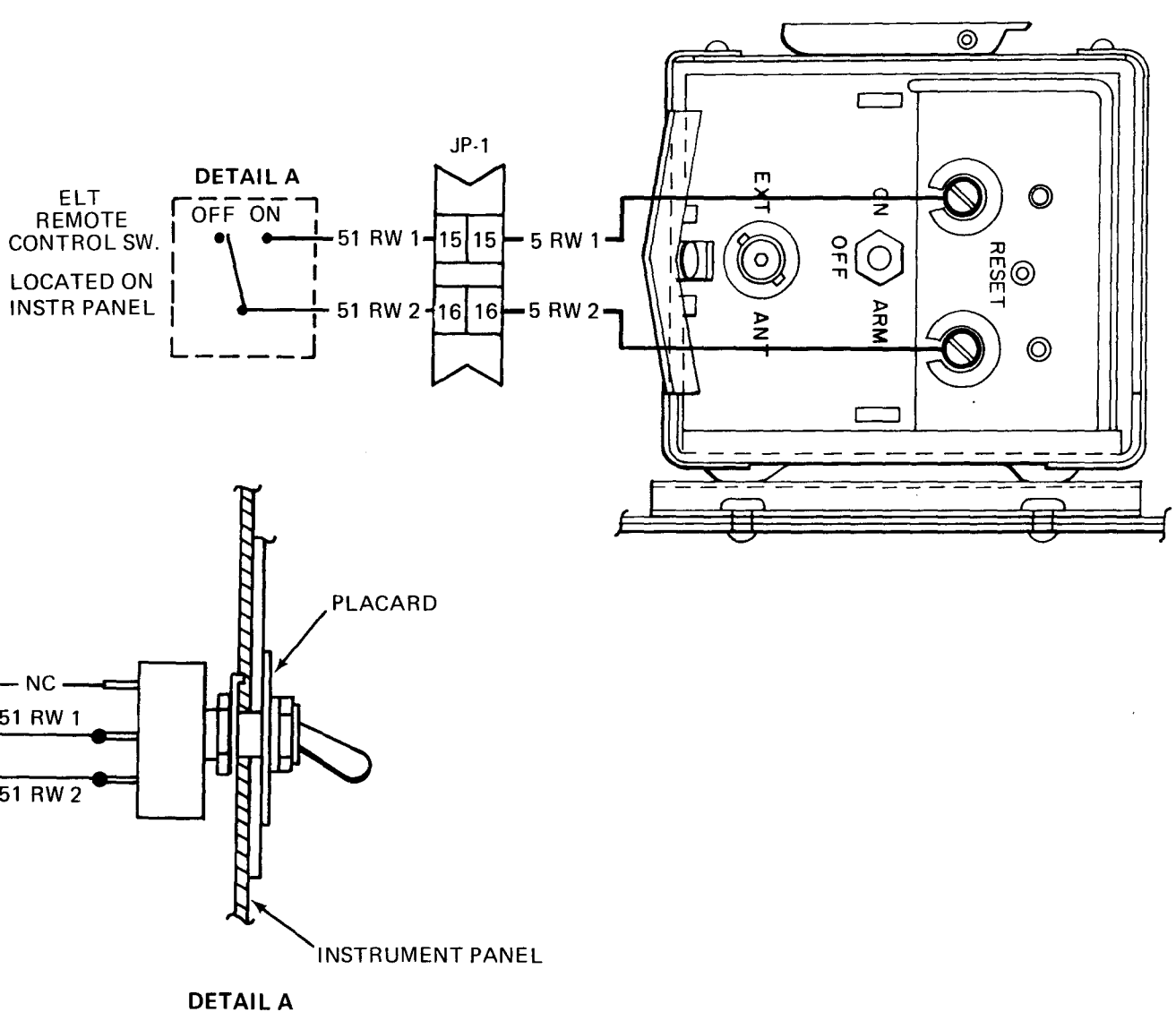

Remote ELT Switch, Wiring Diagram
Figure 101

NARCO ELT-10, EMERGENCY LOCATOR TRANSMITTER - MAINTENANCE PRACTICES

1. Servicing the NARCO ELT-10

NOTE: The ELT-10 contains nine (9) dry cell batteries in a separate battery pack. Since the batteries are not kept charged by aircraft power, they must be periodically replaced. See NARCO owner's manual, 03716-0601 for battery replacement schedule.

A. Removal of Battery Pack

- (1) Set the ON-OFF-ARM switch to OFF. Disconnect antenna.
- (2) Remove the ELT unit from the aircraft.
- (3) Extend the built-in antenna.
- (4) Remove the four (4) screws that attach the battery pack to the transmitter.
- (5) Carefully pull the transmitter away from the battery pack. Do not jerk on the wires.

CAUTION: IN DISPOSITION OF THE BATTERY, DO NOT THROW IN FIRE.

- (6) Release the battery pack wires (quick disconnect) from the terminals at the transmitter. Dispose of battery pack.

B. Installation of Battery Pack

- (1) Connect the battery pack wires to the transmitter.
- (2) Insert the transmitter into the battery pack, be careful not to pinch wires.

NOTE: The battery pack is shipped with a sealant on the inside lip so a water tight seal will be retained. DO NOT REMOVE THIS SEALANT!

- (3) Replace the four (4) attaching screws. If the four holes do not line up, rotate the battery pack 180 degrees and insert.
- (4) Slide the built-in antenna into its holding slot.
- (5) Install the ELT unit in the aircraft.
- (6) Attach the antenna lead to the ELT. Make sure the antenna separator prevents contact between the portable antenna finger and the ELT antenna.
- (7) Perform checkout of ELT system. See test section of this chapter.
- (8) Depress the reset button.
- (9) Place the ON-OFF-ARM switch to ARM.

2. Servicing the NARCO ELT-10C

NOTE: The ELT-10C contains a lithium hydroxide battery and must be carefully handled.

A. Removal of Battery Pack

- (1) Gain access to ELT unit by removing inspection cover on left side of empennage.
- (2) Set the ON-OFF-ARM switch to OFF. Disconnect antenna.
- (3) Remove the ELT unit from the aircraft.
- (4) Extend the built-in antenna.
- (5) Remove the four (4) screws that attach battery pack to the transmitter.
- (6) Separate the two sections. If necessary, use knife to assist in release of sealant.
- (7) Unsnap the battery pack from the transmitter. Remove remaining sealant by rubbing with fingers.

B. Installation of Battery Pack

- (1) Snap battery pack to transmitter connector.
- (2) Apply thin bead of RTV sealant around the perimeter of transmitter section.
- (3) Fit the two sections together. Assure that screw holes align properly.
NOTE: Do not press sections together.
- (4) Apply a very small amount of sealant to countersink of each screw hole.
- (5) Replace the four (4) attaching screws. Tighten screws to bring two sections together. **DO NOT OVERTIGHTEN!**
- (6) Wipe away excess sealant.
- (7) Slide the built-in antenna into its holding slot.
- (8) Install the ELT unit in the aircraft. Attach antenna.
- (9) Perform checkout of ELT system. See test section of this chapter.
- (10) Depress the reset button and place ON-OFF-ARM switch to ARM.
- (11) Replace inspection cover.

3. Removal and Installation of ELT-10 () System Components

A. Removal and Installation of ELT-10 () Unit

To gain access to the ELT-10 unit, remove the left side empennage inspection cover. Disconnect antenna lead and remove mounting hardware. Remove ELT-10 unit. Reverse the procedure to install ELT-10 unit.

NOTE: Ensure that the ON-OFF-ARM switch is OFF when removing or installing ELT-10 unit. Depress reset button and place switch in ARM position after installation.

B. Removal of Antenna (See Figure 201)

- (1) Unscrew the 12 fasteners holding the dorsal fin to the vertical stabilizer.
- (2) Slide the dorsal fin forward. The antenna will slip through the grommet. Continue sliding the fin forward until the antenna can be reached.
- (3) Obtain access to the ELT. Disconnect the antenna lead from the ELT.
- (4) Unscrew the nut cap from the antenna. Remove the nut cap and the two washers from the antenna.
- (5) Open the three stick clamps from the aircraft structure.
- (6) Pull the antenna down and through the aircraft structure.

NOTE: The antenna and coaxial lead are furnished as one assembly.

C. Installation of Antenna (See Figure 201)

- (1) Place the washers and the "O" ring on the antenna in proper sequence.
- (2) Run the antenna through the structure and out through the skin. Place the spring washer, washer, and nut cap (in correct sequence) on the antenna and tighten.
- (3) Attach the antenna lead to structure using the stick clamps (3 places).
- (4) Slowly slide the dorsal fin rearward while fitting the antenna through the grommet.
- (5) Work the antenna through the grommet. Check that there are no bends in the antenna before fitting the dorsal fin to the vertical stabilizer.
- (6) Using the 12 fasteners, attach the dorsal fin to the vertical stabilizer.
- (7) Attach the antenna lead to the ELT. Assure the antenna separator keeps the portable antenna contact finger from touching the ELT antenna.
- (8) Perform an operational checkout of the ELT.

4. Adjustment/Test of NARCO ELT-10

A. Test of NARCO ELT-10 SYSTEM

WARNING: COORDINATE THIS PROCEDURE WITH LOCAL ATC BEFORE STARTING. THIS PROCEDURE ENTAILS A TEST OF EMERGENCY TRANSMISSIONS, AND A LACK OF COORDINATION MAY LEAD TO AN UNTIMELY DISPERSAL OF EMERGENCY PERSONNEL AND VEHICLES.

- (1) Obtain access to the ELT. See Figure 201.
- (2) After coordination, depress the RESET button, then place the ON-OFF-ARM switch to ON. As soon as ATC acknowledges transmission, place switch to OFF. Depress the RESET button, then place switch to ARM.
- (3) Recheck with ATC to assure there are no transmissions from the ELT.
- (4) Monitor for transmission on COM radio with frequency selector set for 121.5 MHZ.

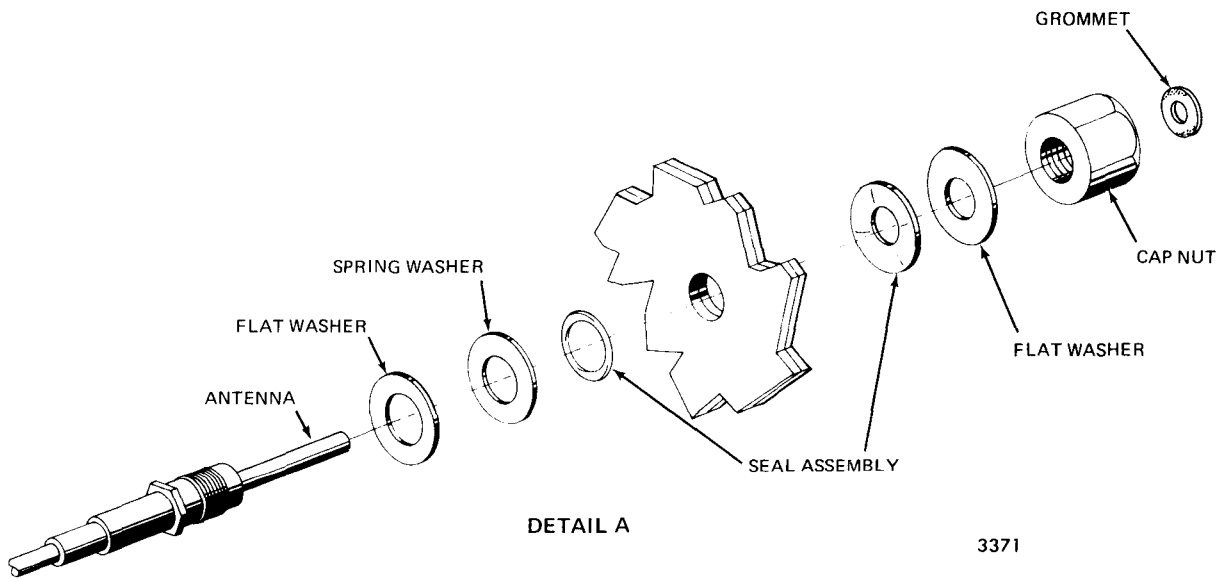
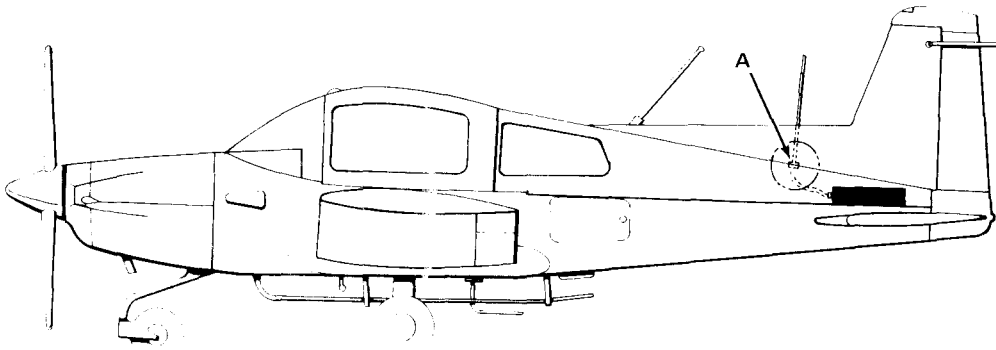

Removal and Installation of ELT-10 Antenna
Figure 201

AA-5 SERIES
MAINTENANCE MANUAL

CHAPTER 24
ELECTRICAL POWER
TABLE OF CONTENTS

| <u>NUMBER</u> | | <u>PAGE</u> |
|---------------|--------------------------------|-------------|
| 24-0 | ELECTRICAL POWER | |
| | Description | 1 |
| | General | 1 |
| 24-0-1 | GENERAL ELECTRICAL INFORMATION | |
| | Description | 1 |
| | General | 1 |
| | Wire Identification | 1 |
| | Electrical Load Analysis | 6 |
| | Maintenance Practices | 201 |
| | Diode Test | 201 |
| 24-3-0 | ELECTRICAL POWER SUPPLY SYSTEM | |
| | Description/Operation | 1 |
| | Battery | 1 |
| | Battery Relay | 1 |
| | Troubleshooting | 101 |
| | Maintenance Practices | 201 |
| | Servicing | 201 |
| | Visual Check | 201 |
| | Cleaning Battery | 201 |
| | Determining State of Charge | 201 |
| | Battery Charging | 201 |
| | Battery Box | 202 |
| | Removal/Installation | 203 |
| | Battery Removal | 203 |

**AA-5 SERIES
MAINTENANCE MANUAL**

| <u>NUMBER</u> | <u>PAGE</u> |
|---|-------------|
| Battery Installation | 203 |
| Battery Relay Removal | 203 |
| Battery Relay Installation | 204 |
| Operational Check of Battery | 204 |
| 24-3-2 ALTERNATOR SYSTEM | |
| Description/Operation | 1 |
| Alternator | 1 |
| Alternator Overvoltage Protection | 1 |
| Voltage Regulator | 1 |
| Troubleshooting | 101 |
| Maintenance Practices | 201 |
| Removal/Installation | 201 |
| Alternator Removal | 201 |
| Alternator Installation | 201 |
| Alternator Overvoltage Protection Diode — Replacement | 201 |
| Alternator Overvoltage Protection Relay — Replacement | 202 |
| Voltage Regulator Removal/Installation | 202 |
| Voltage Regulator Removal | 202 |
| Voltage Regulator Installation | 202 |
| Operational Check of Alternator | 203 |
| 24-4-1 EXTERNAL POWER | |
| Description/Operation | 1 |
| General | 1 |
| Maintenance Practices | 201 |
| External Power Receptacle Removal/Installation | 201 |
| External Power Receptacle Removal | 201 |
| External Power Receptacle Installation | 201 |

ELECTRICAL POWER – DESCRIPTION

1. General

This chapter describes the electrical power system and its operation. This covers the battery system, alternator system, and external power system.

The battery system consists of the battery, battery relay, and associated wiring. The alternator system consists of the alternator, voltage regulator, and alternator overvoltage protection diode. The external power system consists of the external power receptacle and associated wiring.

On AA5A-0523 and subsequent and AA5B-0693 and subsequent, the overvoltage diode is replaced by an overvoltage relay. Also an alternator warning light has been added to the instrument panel.

AA-5 SERIES
MAINTENANCE MANUAL

GENERAL ELECTRICAL INFORMATION - DESCRIPTION

1. General

This section covers general aspects of design and construction common to all AA-5, AA-5A and AA-5B electrical systems. Details of actual systems are discussed in their appropriate section of this manual. The following information is intended to lay the ground work for a basic understanding of the overall electrical systems design so that maintenance personnel can better troubleshoot those systems causing difficulty.

2. Wire Identification

There are two schemes employed in assigning electrical wire codes. One scheme is used when several wiring diagrams are used. Another is used for color coding wires in the circuits specified in all radio systems and/or autopilots as applicable.

A. When multiple wiring diagrams are used for a model, the code is as follows:

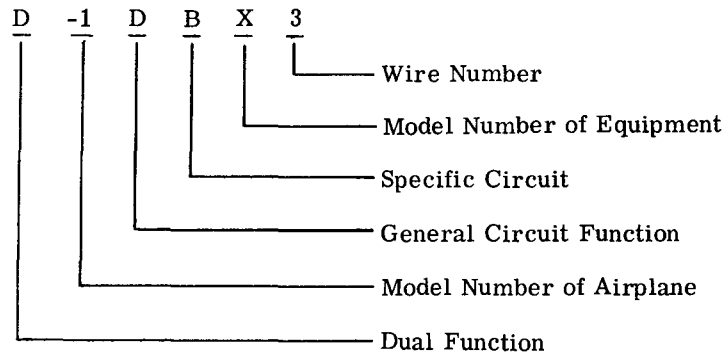

- (1) Dual Function: In the case of duplicate circuits performing the same function having the same circuit codes, wire sequence numbers are assigned in consecutive order for one of the circuits and then begin again at the source of power with the same circuit codes preceded by the coded letter "D".
- (2) Model Number of Aircraft: A number is used to represent the aircraft model. In the case where a wire is used on both aircraft, both model numbers will be present.
- (3) General Circuit Function: An alphabetical character used to indicate general system in which the wire is used.
- (4) Specific Circuit: An alphabetical character used to indicate specific systems in which the wire is used.
- (5) Model Number of Equipment: When required, a third letter will be used to designate model number of equipment.
- (6) Wire Number: Wire sequence numbers are assigned to each individual wire within a circuit at the time of preparation of the wiring diagram. The sequence number shall be assigned in numerical order, beginning with the number one (1) for each specific circuit. Number of individual wires should begin at the source of power and run in consecutive order throughout the circuit.

AA-5 SERIES
MAINTENANCE MANUAL

CIRCUIT FUNCTION AND SPECIFIC CIRCUIT CODE LETTERS:

A - Unassigned

B - Photographic

C - Control Surface

CA - Automatic Pilot

CB - Not Used

CC - Wing Flaps

CD - Elevator Trim

D - Instrument (Other than Flight or Engine Instrument)

DA - Ammeter

DB - Flap Position Indicator

DC - Clock

DD - Voltmeter

DE - Outside Air Temperature

DF - Flight Hour Meter

E - Engine Instrument

EA - Carburetor Air Temperature

EB - Fuel Quantity Gage and Transmitter

EC - Cylinder Head Temperature

ED - Oil Pressure

EE - Oil Temperature

EF - Fuel Pressure

EG - Tachometer

EH - Torque Indicator

EJ - Instrument Cluster

F - Flight Instrument

FA - Bank and Turn

FB - Pitot Static Tube Heater and Stall Warning Heater

FC - Stall Warning

FD - Speed Control System

AA-5 SERIES
MAINTENANCE MANUAL

N - Unassigned

O - Not Used

P - D. C. Power

PA - Battery Circuit

PB - Generator Circuits

PC - External Power Source

Q - Fuel and Oil

QA - Auxiliary Fuel Pump

QB - Oil Dilution

QC - Engine Primer

QD - Main Fuel Pumps

QE - Fuel Valves

R - Radio (Navigation and Communication)

RA - Instrument Landing

RB - Command

RC - Radio Direction Finding

RD - VHF

RE - Homing

RF - Marker Beacon

RG - Navigation

RH - High Frequency

RK - UHF

RL - Low Frequency

RM - Frequency Modulation

RP - Audio System and Audio Amplifier

RR - Distance Measuring Equipment (DME)

S - Radar

T - Unassigned

U - Miscellaneous Electronic

V - Unassigned

W - Warning and Emergency

AA-5 SERIES
MAINTENANCE MANUAL

FE - Indicator Lights

G - Landing Gear

GA - Actuator

GB - Retraction

GC - Warning Device (Horn)

GD - Limit Switches

GE - Indicator Lights

H - Heating, Ventilating and De-icing

HA - Anti-icing

HB - Cabin Heater

HC - Cigar Lighter

HD - De-ice

I - Not Used

J - Ignition

JA - Magneto

K - Engine

KA - Starter

L - Lighting

LA - Cabin

LB - Instrument

LC - Landing

LD - Navigation

LE - Taxi

LF - Rotating Beacon

LG - Radio

LH - De-ice

LJ - Fuel Selector

M - Miscellaneous

MA - Cowl Flaps

MB - Electrically Operated Seats

AA-5 SERIES
MAINTENANCE MANUAL

X - A. C. Power

Y - Unassigned

Z - Unassigned

B. When color coding is employed, colors shall be assigned as tabled below:

| FUNCTION CIRCUITS | GAUGE | BASE COLOR (or solid) | STRIPE COLOR |
|----------------------|-------|-----------------------------|-----------------|
| | 16 | Red | None |
| | 18 | Red | Black |
| A+ Power | | Red | White |
| | 20 | Red | Green |
| | 22 | Red | Yellow |
| Ground | 16 | Black | None |
| | 18 | Black | White |
| Mike Ground | 22 | Black | None |
| Radio Lights Dim | 18 | Yellow | None |
| | 22 | Tan | None |
| Mike Audio | | Tan (shielded) | None |
| Mike Key | 22 | White | Black |
| Radio Speaker | 20 | Green | None |
| Headphones | 22 | Blue | None |
| Dev +1 | 22 | Gray | Red |
| Dev -1 | 22 | Gray | Green |

NOTES:

- "Dev +" and "Dev -" circuits are for use in autopilots and any associated omni indicator circuit to which it connects.
- All other color coded wires are for general use in multi-conductor radio and autopilot harness assemblies.

AA-5 SERIES
MAINTENANCE MANUAL

ELECTRICAL LOAD ANALYSIS

CURRENT DRAIN
AMPS

CONTINUOUS LOADS

| | |
|-----------------------------------|-------|
| Oil Temperature Gauge | 0.50 |
| Fuel Gauge Light Left | 0.03 |
| Fuel Gauge Light Right | 0.03 |
| Fuel Gauge Left | 0.10 |
| Fuel Gauge Right | 0.10 |
| Battery Relay | 0.60 |
| Flashing Beacon | 11.00 |
| Pitot Heat | 6.50 |
| Navigation Lights | 4.52 |
| Instrument Lights | 2.31 |
| Turn and Bank Indicator | 0.30 |
| Hour Meter | 0.50 |
| TOTAL | 26.49 |

SHORT TERM LOADS

| | |
|--------------------------------|------------|
| Stall Warning System | 0.40 |
| Electric Fuel Pump | 0.65 |
| Electric Flap Motor | 15.00 max. |
| Courtesy Lights (2) | 0.66 |
| Cigar Lighter | 6.50 |
| Landing Light | 7.30 |
| TOTAL | 30.51 |

**AA-5 SERIES
MAINTENANCE MANUAL**

ELECTRICAL LOAD ANALYSIS (Continued)

AVIONICS EQUIPMENT

| <u>Genave</u> | <u>REC</u> | <u>TRANS</u> | <u>King</u> | <u>REC</u> | <u>TRANS</u> |
|---|------------|--------------|---|------------|--------------|
| Alpha-200 Transceiver | 2.10 | 2.82 | KX-170 Transceiver | 1.00 | 3.00 |
| Alpha-200A Transceiver | 2.10 | 2.82 | KI-201C Omni Converter | 0.10 | — |
| Alpha-300 Transceiver | 2.10 | 2.82 | KI-211C ILS System | 0.20 | — |
| Alpha-360 Transceiver | 1.18 | 3.10 | KR-85 ADF Rec. | 1.00 | — |
| Theta-100/200 ILS Converters | 0.43 | — | KT-225 ADF Indicator | 0.16 | — |
| Beta-500 X-Ponder | 1.40 | 2.40 | KN-60C DME | 3.00 | 3.00 |
| Beta-4096 X-Ponder | 1.40 | 2.40 | KT-75 X-Ponder | 1.80 | 1.80 |
| Tau-81 Audio Amp | 1.00 | — | KX-170A | 1.26 | 4.50 |
| Delta-202 Marker Rec. | 0.08 | — | KX-170B | 1.38 | 4.50 |
| Phi-20 Glideslope Rec. | 0.15 | — | KX-170BE | 1.38 | 4.50 |
| | | | KX-175 | 1.26 | 4.50 |
| | | | KX-175BE | 1.38 | 4.50 |
| <u>Narco</u> | <u>REC</u> | <u>TRANS</u> | KT-76 | 1.30 | 1.30 |
| Escort-110 Transceiver | 2.10 | 2.80 | KT-78 | 1.30 | 1.30 |
| Com-10 Transceiver | 0.66 | 2.16 | KI-214 | 0.34 | — |
| Nav-10 Rec/Converter | 0.82 | — | KMA-20/with Marker | 1.40 | — |
| Com-11 Transceiver | 0.66 | 2.16 | KR-86 | 0.66 | — |
| Nav-11 Rec/Converter | 0.62 | — | KX-175B | 1.38 | 4.50 |
| Nav-12 Rec/Converter/ILS | 0.62 | — | KI-203 | 0.10 | — |
| Nav-14 Rec | 0.92 | — | KI2-204 | 0.20 | — |
| DGO-10DG/ILS/Converter | 1.20 | — | KI-208 | 0.10 | — |
| ADF-31 ADF Receiver/Indicator | 0.64 | — | KI-209 | 0.20 | — |
| ADF-32 ADF Receiver/Indicator | 0.90 | — | | | |
| U. G. R.-2 Glideslope Rec. | 0.23 | — | <u>Collins</u> | <u>REC</u> | <u>TRANS</u> |
| MBT Marker Rec. | 0.19 | — | VHF-150 | .50 | 4.50 |
| AT-50 X-Ponder | 1.10 | 1.10 | VHF-251 | 0.84 | 5.10 |
| Com-10A | 0.96 | 2.50 | VIR-352 | 1.00 | — |
| Com-11A | 0.96 | 2.50 | VIR-351/IND-350/VHF-251 | 1.83 | 5.10 |
| Com-11B | 0.76 | 3.50 | VHF-251/VIR-351/ IND-351/GLS-350 | 2.33 | 5.10 |
| Com-111 | 0.96 | 2.50 | RCR-650/IND-650/ANT-650 | 1.10 | — |
| Com-111B | 0.76 | 3.50 | TDR-950 | — | — |
| Nav-111 | 0.62 | — | AMR-350 | — | — |
| Nav-112 | 0.62 | — | | | |
| Nav-114 | 0.92 | — | <u>Edo-Aire Mitchell</u> | <u>REC</u> | <u>TRANS</u> |
| PDF-35 | 0.93 | — | Century I Autopilot | 1.25 | — |
| ADF-140 | 1.12 | — | Century IIB Autopilot | 2.00 | — |
| UGR-2A | 0.23 | — | | | |
| UGR-3 | 0.23 | — | | | |
| CP-25 | 0.41 | — | | | |
| CP-25B | 0.41 | — | | | |
| CP-125 | 0.41 | — | | | |
| AT-50A | 1.60 | 1.60 | | | |
| DME-190 | 3.00 | 3.00 | | | |
| Com-120 | .76 | 3.50 | | | |
| Nav-121 | .55 | — | | | |
| Nav-122 | .55 | — | | | |
| CP-135 | .41 | — | | | |
| AT-150 X-Ponder | 1.60 | 1.60 | | | |
| ADF-141 | 1.12 | — | | | |

**AA-5 SERIES
MAINTENANCE MANUAL**

GENERAL ELECTRICAL — MAINTENANCE PRACTICES

1. Diode Test

NOTE: Whenever a solenoid or switch is replaced that has a diode used with it, the corresponding diode should be checked. For accurate test, the diode must be disconnected from circuit.

A. Check diode as follows:

- (1) Obtain an ohmmeter and set up on OHMS.
- (2) Position the test leads across the diode and record the ohmic reading.
- (3) Reverse the test leads and again record the ohmic reading.
- (4) The first reading must be ten times greater or less than the second reading.
- (5) Replace diodes not meeting (4) above.

ELECTRICAL POWER SUPPLY SYSTEM — DESCRIPTION/OPERATION

1. General

Power for the electrical system is provided by an alternator and/or battery. The alternator serves as the main component to power the electrical system and charge the battery during normal conditions. The battery is used for starting the engine and powering the electrical system when alternator power is not available (engine not running). The battery also powers the electrical system in case of alternator system failure.

A split rocker type master switch is used which performs two functions. The right side energizes the battery relay and the left side supplies power to the voltage regulator. The battery relay, when energized, connects power to the electrical system and the starting system. The voltage regulator, receiving power from the battery via the master switch, energizes the alternator field. With the alternator field energized, the operating alternator will produce an output to the electrical system. The voltage regulator varies the output voltage of the alternator to meet the requirements of the electrical system loads. An ammeter is installed into the system to provide an indication of current flow from or to the battery.

An external power receptacle is offered as optional equipment to supplement the battery system for starting and ground operation.

Diodes are used in the aircraft electrical system across some relays and switches (including the master switch) to dissipate back EMF and provide extended relay life. These relays and switches will function with defective diodes, but their life will be shortened.

The negative side of the battery is connected to the aircraft structure (negative ground). This provides a ground for system through use of aircraft structure. The positive side of the battery is connected to the coil of the battery relay. This relay remains in a relaxed state until the master switch is placed to the ON position.

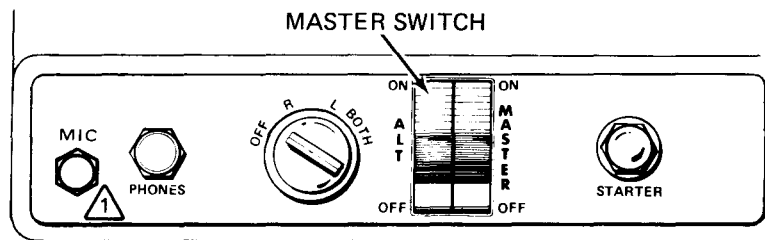
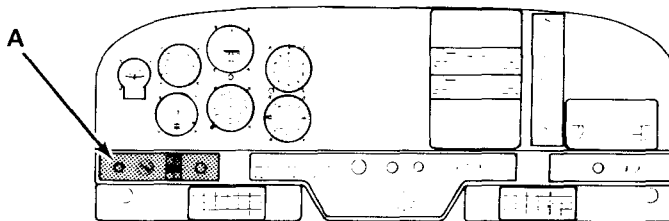

DETAIL A

3100

1 1978 MODELS AND SUBSEQUENT
AA5A-0523 AND SUBSEQUENT
AA5B-0693 AND SUBSEQUENT

Master Switch
Figure 1

AA-5 SERIES
MAINTENANCE MANUAL

Placing the MASTER side of the split master switch in the ON position provides a ground for the battery relay energizing this relay. With the battery relay energized, a circuit exists from the battery through an ammeter to the bus bar.

The bus bar powers the electrical equipment and accessories furnished on the aircraft (excluding hourmeter, dome light, and clock). The energized relay will also allow power from the battery to the starter solenoid.

Placing the ALT side of the split master switch to the ON position will provide a circuit from the bus bar through a 5 amp alternator field circuit breaker to the voltage regulator. The voltage regulator will supply and regulate voltage to the alternator field. With the alternator operating (engine running) and the field energized, the alternator will develop electrical power. The alternator supplies power to the bus bar through a 60 amp alternator circuit breaker. An overvoltage diode in the alternator load protects the alternator against damage due to overload. With alternator power available, the battery will be charged by the alternator. The ammeter, which is in series with the battery and bus bar will indicate the current flow to the battery. When the battery reaches a state of full charge, the ammeter will show an indication of minimum rate.

AA5A-0523 and subsequent and AA5B-0693 and subsequent, the overvoltage diode is replaced by an overvoltage relay and an indicator light is placed on the instrument panel to alert the pilot of an overvoltage condition.

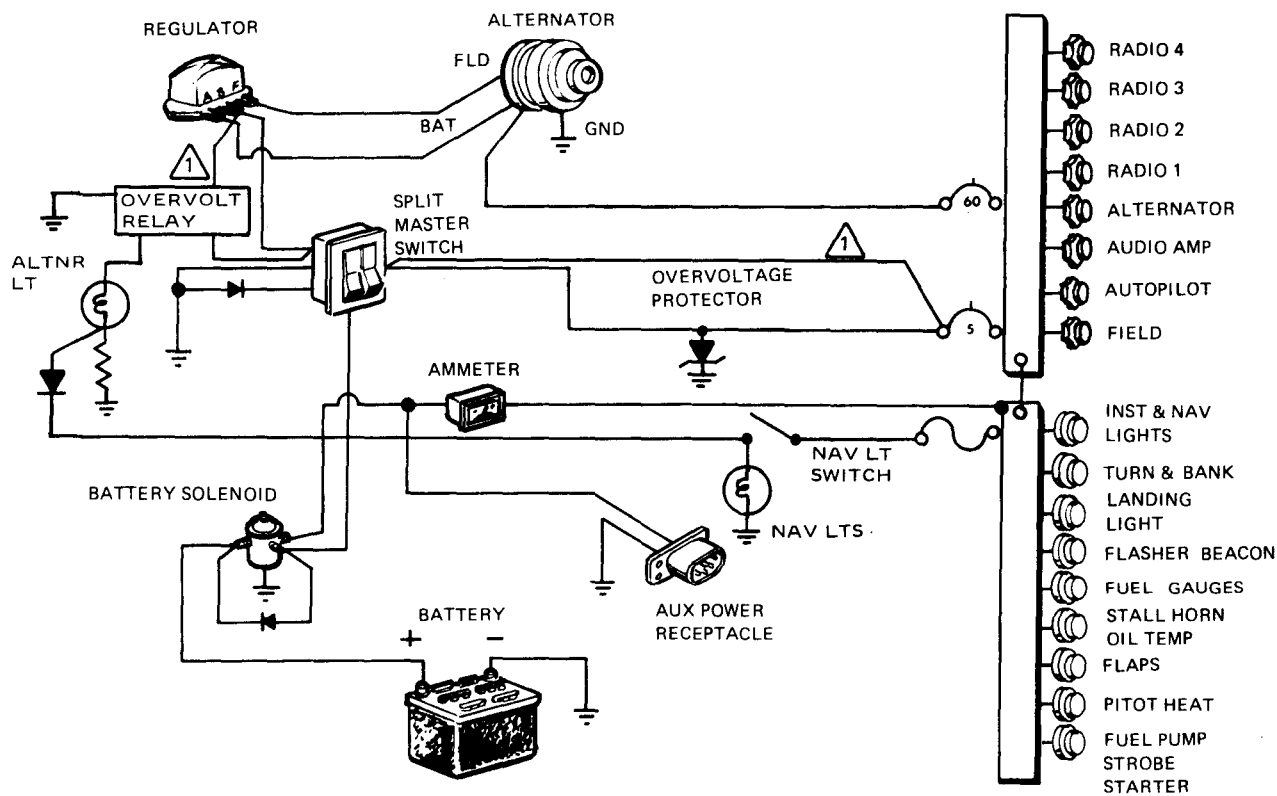

3479

1 1978 MODELS
AA5A-0523 AND SUBSEQUENT
AA5B-0693 AND SUBSEQUENT

DC Power System
Figure 2

AA-5 SERIES
MAINTENANCE MANUAL

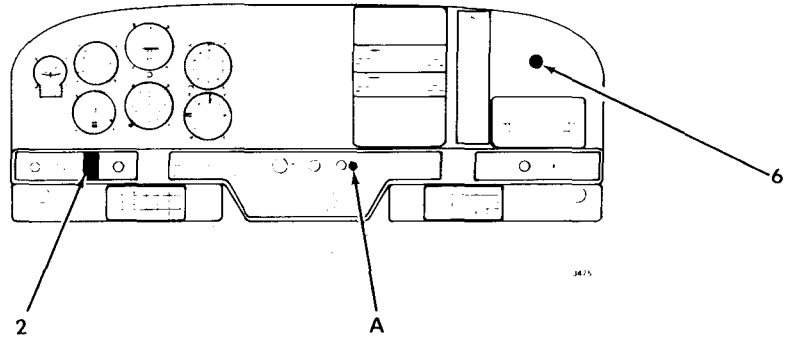

- 1. OVERVOLTAGE PROTECTION DIODE
 - 2. MASTER SWITCH
 - 3. BATTERY SOLENOID
 - 4. ALTERNATOR
 - 5. BATTERY
 - 6. ALTERNATOR LIGHT
 - 7. OVERVOLTAGE RELAY (INSIDE FIREWALL)
- } AA5A-0523 AND SUBSEQUENT
AA5B-0693 AND SUBSEQUENT

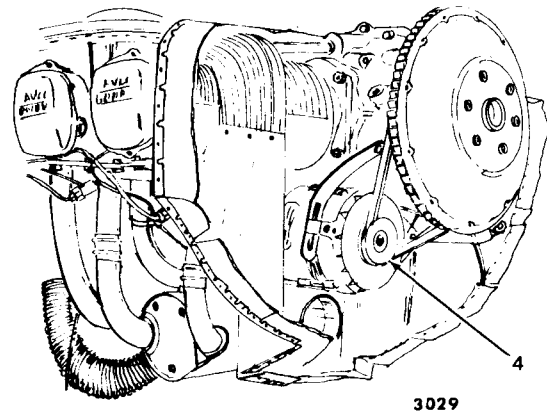
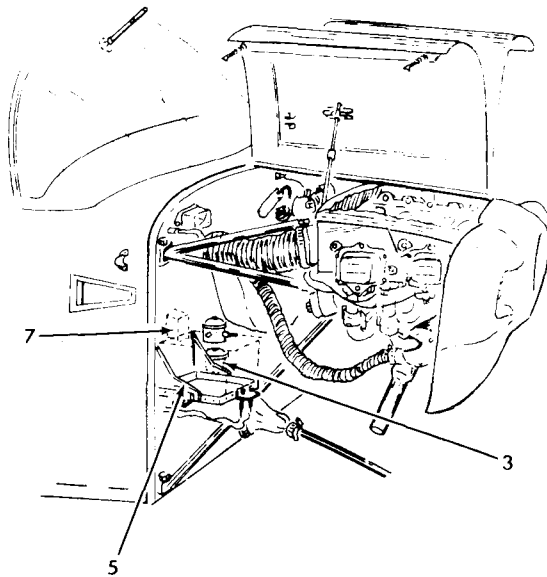
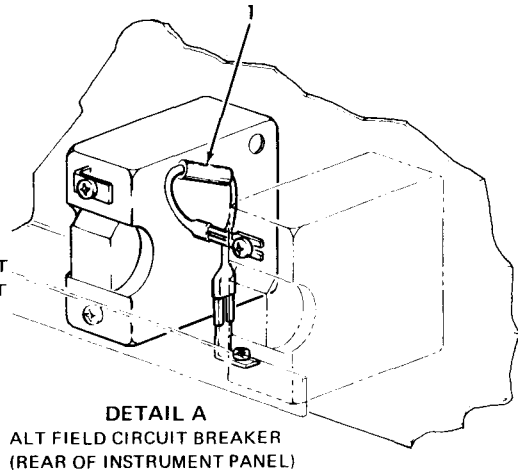

Electrical Component Location Chart
Figure 3

AA-5 SERIES
MAINTENANCE MANUAL

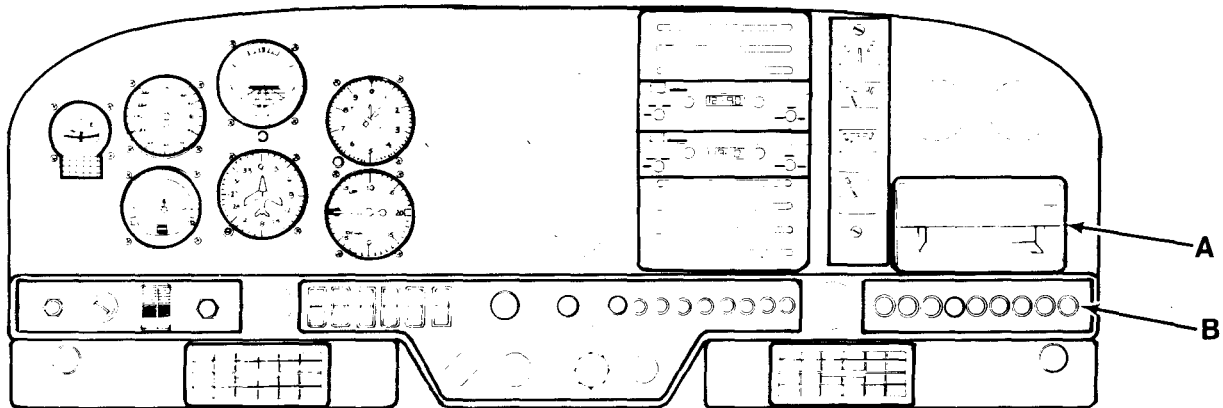

3475

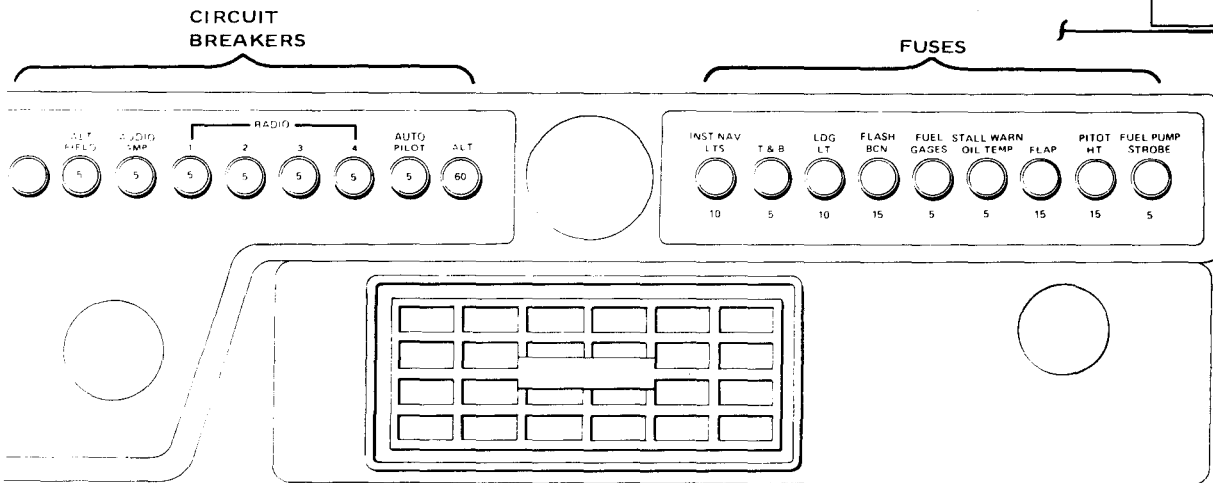
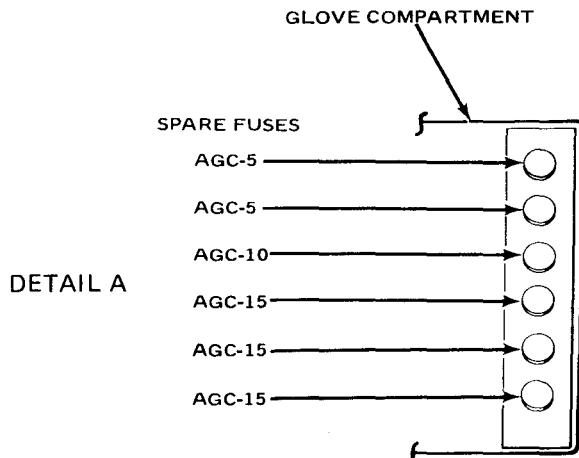

DETAIL B

3088

Circuit Breaker and Fuse Panel — Locations
Figure 4

BATTERY SYSTEM – DESCRIPTION/OPERATION

1. General

The battery system consists of the battery, a battery relay, ammeter, switch, circuit breakers and wiring.

2. Battery (See Figure 1.)

The battery is a 12V, 25 ampere hour, dry-charge type. The battery is located on the right forward side of the firewall. The battery is used to provide engine starts and supply power to the electrical system when alternator power is not available. The battery is also used as an emergency supply in the event of alternator failure.

Under normal use, a battery being charged and discharged will decompose the water from the electrolyte by electrolysis. When the water is decomposed, hydrogen and oxygen gases are formed which escape into the atmosphere through the battery vent system. The low water level is caused by this decomposition of water from the electrolyte. Distilled water should be added as necessary to maintain the electrolyte level. An ammeter is incorporated into the battery system to indicate the current flow either to or from the battery. The ammeter is wired in series from the battery to the bus. Current will flow from the battery to the bus to power the electrical system when alternator power is not available. This will give a negative indication on the ammeter. With the alternator on the line, the flow of current will be to the battery. This will show a positive indication on the ammeter. The rate of charge (positive indication) will vary at the demand of the battery.

3. Battery Relay (See Figure 2.)

The battery relay is located on the right side of the forward firewall. The relay is a plunger type which is actuated when the master switch is placed to the ON position. With the master switch in the OFF position, the relay isolates the battery from the electrical system. A diode is used across the relay to dissipate back EMF and provide extended relay life. The relay is energized when the master switch is placed to the ON position. A circuit is completed between the battery, through an ammeter to the bus bar. The relay, when energized, also provides a circuit to the starting system.

AA-5 SERIES
MAINTENANCE MANUAL

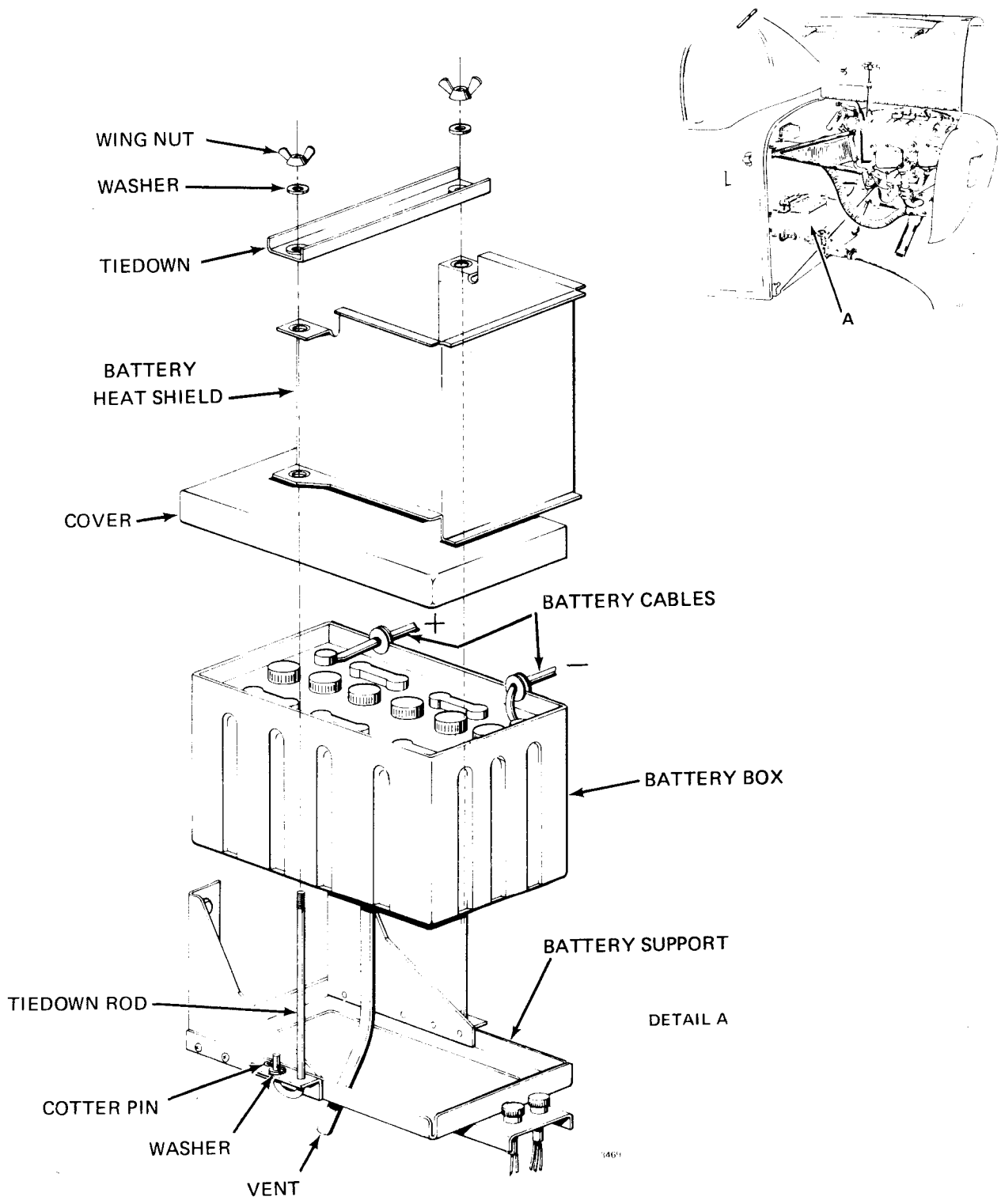

Exploded View of Battery & Battery Box
Figure 1

AA-5 SERIES
MAINTENANCE MANUAL

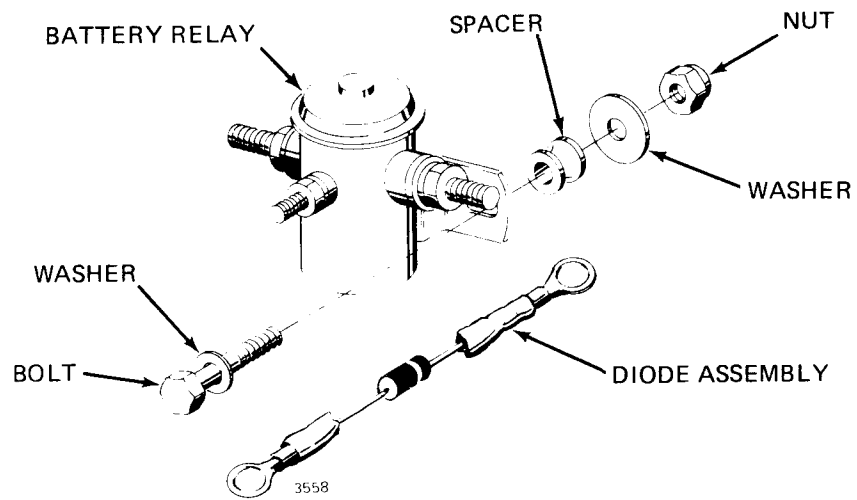
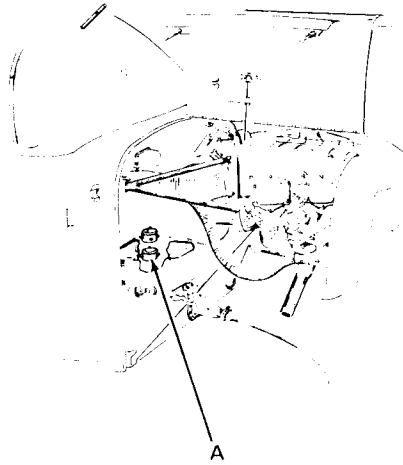

DETAIL A

Exploded View of Battery Relay
Figure 2

AA-5 SERIES
MAINTENANCE MANUAL

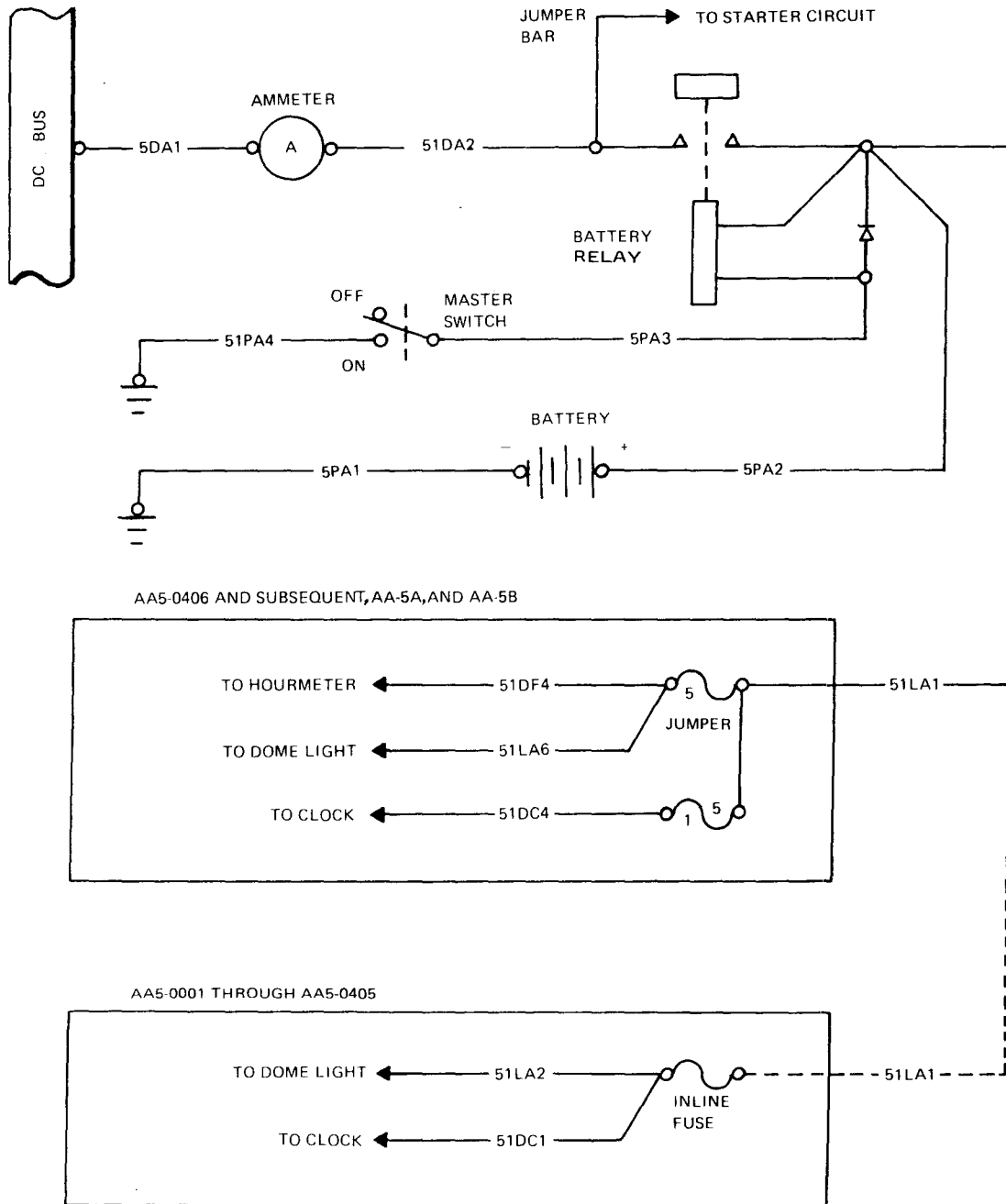

3480

Battery Circuit
Figure 3

BATTERY SYSTEM – TROUBLESHOOTING

| TROUBLE | PROBABLE CAUSE | REMEDY |
|---|--|--|
| System not energized when master switch is turned on. | Dead battery. | Recharge or replace. |
| | Defective wiring. | With master switch OFF, check entire DC power system for an open circuit with a continuity tester. |
| | Defective battery relay. | Connect, in sequence, a voltmeter to each battery relay terminal and check voltage with master switch on. If no voltage is indicated from either terminal, check and/or replace relay. |
| | Defective master switch. | Remove switch from aircraft and check with continuity tester. Replace switch if defective. |
| Battery discharge. | Charging rate too low. | Replace voltage regulator. |
| | Battery left standing too long. | Recharge or replace. |
| | Equipment left on accidentally. | Recharge battery. |
| | Impurities in electrolyte. | Replace battery. |
| | Cell separator broken. | Replace battery. |
| | Short circuit in wiring. | Check wiring. |
| | Loose or broken alternator belt. | Tighten or replace. |
| | Corroded or loose battery connections. | Clean and tighten. |
| Short battery life. | Low charging rate. | Replace voltage regulator. |
| | Impurities in electrolyte. | Replace battery. |
| | Battery left standing too long. | Recharge or replace. |
| | Sulfation due to nonuse. | Replace. |
| | Level of electrolyte being below top of plates | Maintain electrolyte at proper level. |
| Battery uses excessive amount of water | Charging rate too high | Correct charging rate. |
| | Cracked case | Replace battery. |
| | Shorted cell | Replace battery. |

AA-5 SERIES
MAINTENANCE MANUAL

| TROUBLE | PROBABLE CAUSE | REMEDY |
|---|---|---|
| | Shorted diode in alternator | Test diodes and replace as required. |
| Battery polarity reversed | Connected backwards on air-plane or charger | Battery should be slowly discharged completely and then charged correctly and tested. |
| Battery freezes | Undercharged or discharged battery | Replace. |
| | Water added and battery not charged immediately | Always recharge battery for 1/2 hour following addition of water in freezing weather. |
| Ammeter indicates discharge with engine operating | Alternator belt loose or broken | Tighten or replace belt. |
| | Open circuit between alternator and bus bar | Check wiring for clean, secure connections and repair as necessary. |

BATTERY SYSTEM — MAINTENANCE PRACTICES

1. Servicing

A. Visual Check

- (1) Remove battery cover — (see Battery — Removal/Installation).
- (2) Inspect battery terminals for corrosion. If corrosion exists, terminal should be cleaned as described in Cleaning Battery.
- (3) Inspect for a low water level condition. Distilled water should be added as required to bring the level up to the split rings.
- (4) Inspect for plugged vents and clean if necessary.
- (5) Replace battery cover (see Battery — Removal/Installation).

B. Cleaning Battery

WARNING: ENSURE THAT EXTERNAL POWER IS DISCONNECTED BEFORE REMOVING BATTERY.

- (1) Remove battery from aircraft (see Battery — Removal/Installation).
- (2) Tighten filler caps to prevent cleaning solution from entering battery.
- (3) Wipe down entire battery with a clean cloth dampened with a solution of bicarbonate of soda (baking soda) and water.
- (4) Wipe battery cable ends with same solution used in Step (3).
- (5) Rinse areas being cleaned with clear water and wipe off excess water. Allow battery to dry before installation.
- (6) Use a brass wire brush or emery cloth to finish cleaning battery cable ends and battery terminals.

C. Determining State of Charge

To determine the state of battery charge, the specific gravity of the battery is checked using a hydrometer. A reading of 1.260 indicates a fully charged battery whereas a reading of 1.225 or below indicates that the battery should be recharged.

D. Battery Charging

WARNING: ALWAYS KEEP SPARKS OR ANY FORM OF IGNITION AWAY FROM BATTERY BEING CHARGED BECAUSE EXPLOSIVE GASES ARE BEING GENERATED DURING THE CHARGING PROCESS.

- (1) Remove battery from aircraft (see Battery — Removal/Installation).
- (2) Place battery in well ventilated area.
- (3) Remove vented caps and check the level of electrolyte. Distilled water should be added as needed to bring level to top of split rings.
- (4) Charge battery as required.
- (5) Replace vent caps and reinstall battery (see Battery — Removal/Installation).

**AA-5 SERIES
MAINTENANCE MANUAL**

E. Battery Box

WARNING: BE CAREFUL WHEN WORKING AROUND BATTERY ACID DEPOSITS. SERIOUS ACID BURNS COULD RESULT IF CONTACT IS MADE WITH ACID DEPOSITS. IF CONTACT IS MADE, WASH IMMEDIATELY WITH SOAP AND WATER.

The battery box, cover, and drain tube should be inspected and cleaned when the battery is removed. The battery box, cover, and drain tube can be cleaned with a strong solution of bicarbonate of soda (baking soda) and water. After cleaning box, cover, and drain tube, flush them thoroughly with water. Inspect box, cover, and drain tube for physical damage. If badly damaged, they should be replaced.

2. Battery Removal/Installation (See Figure 1.)

A. Battery Removal

- (1) Open right half top engine cowl.
- (2) Remove the two wing nuts. Withdraw the battery hold-down bracket.
- (3) Remove the battery box lid (cover).

CAUTION: REMOVE THE GROUND (NEGATIVE) CABLE FIRST TO PREVENT ACCIDENTAL SHORT.

- (4) Disconnect the battery cables.
- (5) Remove the battery heat shield.
- (6) Remove the battery and battery box by lifting and sliding forward

B. Battery Installation

CAUTION: WHEN INSTALLING THE BATTERY, BE SURE TO CHECK FOR CORRECT POLARITY (NEGATIVE TO GROUND) TO PREVENT DAMAGE TO THE ELECTRICAL SYSTEM.

- (1) Install battery into battery box and slide battery box onto battery box support bracket.
- (2) Install battery heat shield.

CAUTION: CONNECT GROUND (NEGATIVE CABLE) LAST TO PREVENT ACCIDENTAL SHORT CIRCUITING DURING INSTALLATION.

- (3) Connect battery cables and coat terminals with petroleum jelly to reduce corrosion.
- (4) Replace the battery box lid (cover).
- (5) Replace the battery hold-down bracket.
- (6) Replace the two wing nuts.
- (7) Close right half top engine cowl.
- (8) Perform Operational Check.

3. Battery Relay Removal/Installation (See Figure 2.)

A. Battery Relay Removal

- (1) Open upper cowl and remove lower cowl.
- (2) Remove ground (negative) cable from battery terminal. Pull cable clear of battery and battery box (see Battery — Removal Steps 2 through 4).
- (3) Pull rubber insulators clear of battery terminal on battery relay. Remove hardware and remove cable 5PA2 from battery terminal on relay.
- (4) Remove attaching hardware and wire 5PA3 from center terminal. Remove diode from battery terminal and center terminal. Retain for future use.
- (5) Remove attaching hardware and remove battery solenoid.

B. Battery Relay Installation

CAUTION: ENSURE GROUND (NEGATIVE) CABLE IS DISCONNECTED AND CLEAR OF BATTERY TERMINAL BEFORE INSTALLING RELAY.

NOTE: Diode used on relay should be tested and replaced if necessary before installing relay. (See Diode — Maintenance.)

- (1) Secure battery relay on firewall and install attaching hardware.
- (2) Place diode between battery terminal and center terminal. Ensure proper polarity on diode.
- (3) Install wire 5PA3 and attaching hardware on center terminal.
- (4) Install cables 5PA2 and attaching hardware on battery terminal. Slide rubber insulators over the terminal.
- (5) Connect ground (negative) cable to battery (see Battery Installation Steps (3) through (6)).
- (6) Replace lower cowl and close upper cowl.
- (7) Perform operational check per Operational Check.

4. Operational Check of Battery

NOTE: Ensure all fuses are good and all circuit breakers are in.

A. Operational Check

- (1) Place Master switch to ON position.
- (2) Place a heavy drain on the battery (this can be accomplished by turning on the flashing beacon and/or landing light).
- (3) Check for correct operation of flashing beacon and/or landing light.
- (4) Turn flashing beacon and/or landing light off.
- (5) Turn Master switch off.

**AA-5 SERIES
MAINTENANCE MANUAL**

ALTERNATOR SYSTEM — DESCRIPTION/OPERATION

1. Alternator

The 60 ampere alternator is three phase, delta connected with integral silicon diode rectifiers. It is rated at 14 volts, 60 amperes continuous output. The rotor consists of an axial winding with radial interlocking poles which surround the winding. The stator windings are three phase, delta connected and are attached to two diode plates, each of which contain three silicon diodes.

The alternator is susceptible to reverse polarity current because of the silicon diodes. The diodes, having a very high resistance to reverse current flow, are used without a cutout relay such as used on a generator system. The alternator diodes are arranged with their cathodes connected to the bus bar, which is positive, and no back current will flow. If the polarity of the battery is reversed, the diodes will offer no resistance to current flow. If the current rating of the diodes is exceeded, diode failure may result.

The diode plates are connected to the stator windings to accomplish full-wave rectification of AC. The resulting DC output is applied to the bus and sensed by the voltage regulator. The regulator controls the excitation applied to the alternator field thus controlling the output of the alternator. A five amp Alt Field circuit breaker, located on the instrument panel, is placed in series with the bus and the voltage regulator to protect the alternator field circuit.

2. Alternator Overvoltage Protection -- (AA5-0605 and subsequent, and AA5A-0001 through 0522, AA5B-0001 through 0692)

Alternator charging system is susceptible to overvoltage due to a malfunction of the voltage regulator. To protect the aircraft electrical system against this condition, an avalanche overvoltage diode has been shunted across the load side of the ALT. FIELD circuit breaker to ground. This diode will withstand the aircraft's normal bus voltage, but will break down under excessive voltages and eventually short the ALT. FIELD circuit breaker to ground. This will cause the breaker to open, deenergizing the alternator field, disabling the alternator. Reactivation of the field circuit breaker cannot be accomplished until the electrical failure has been corrected and the avalanche diode replaced.

3. Alternator Overvoltage Protection (AA5A-0523 and subsequent and AA5B-0693 and subsequent.)

The aircraft electrical system is protected by an overvoltage relay. The aircraft bus voltage is applied to the overvoltage relay when the alternator side of the split Master switch is placed to the ON position. The relay is designed to withstand the normal bus voltage and allows the voltage to be applied to the voltage regulator. The relay will energize under excessive voltage and remove the input to the voltage regulator. This, in turn, will deenergize the alternator field and the output of the alternator will drop to zero. With the overvoltage relay energized, the alternator indicator light, on the instrument panel, will be illuminated and alert the pilot to the alternator failure. The light will also be illuminated when the alternator side of the split Master switch is in the OFF position, if power is applied to the aircraft bus. To deenergize the overvoltage relay, place the alternator side of the split Master switch to the OFF position. The alternator warning light will glow dimly when the navigation lights are ON and an alternator failure occurs.

4. Voltage Regulator

The alternator voltage regulator is located on the upper right side of the firewall. It contains two relays. One relay is actuated by the aircraft Master switch and connects the regulator to the battery. The second relay is a two-stage, voltage sensitive unit which is used to control the current applied to the field winding of the alternator. When the upper set of contacts on the voltage regulator relay are closed, full bus voltage is applied to the field. This condition will exist when the battery is being heavily charged or when a heavy load is applied to the system. When the upper contacts open and the voltage begins to rise toward normal bus voltage, the voltage to the alternator field is reduced through a resistor network in the base of the regulator, thus reducing the output from the alternator. As the voltage continues to rise, assuming a very light load on the system, the lower contact will close and ground the alternator field, shutting the alternator completely off. Under lightly loaded conditions, the voltage relay will vibrate between the intermediate charge rate and the upper (full output) contacts.

The voltage regulator is temperature compensated so that the battery is supplied with the proper charging voltage for all operating temperatures. With the battery fully charged (aircraft ammeter indicating at or near zero) and a moderate load applied to the system (landing light turned on) the voltage at the bus bar should be within the range shown, according to the air temperature, on the following chart.

| TEMPERATURE | BUS VOLTAGE |
|-------------|-------------|
| 60 - 74°F | 13.8 - 14.1 |
| 75 - 90°F | 13.7 - 14.0 |
| 91 - 100°F | 13.6 - 13.9 |

AA-5 SERIES
MAINTENANCE MANUAL

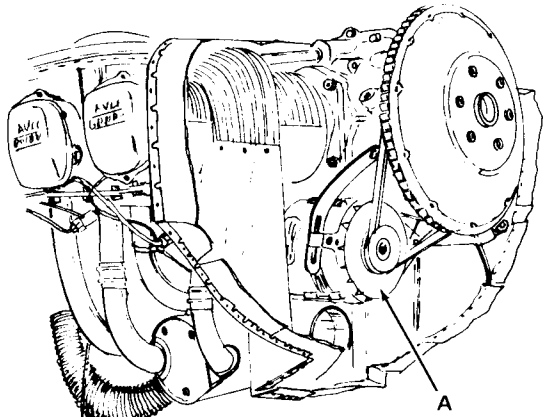

3029

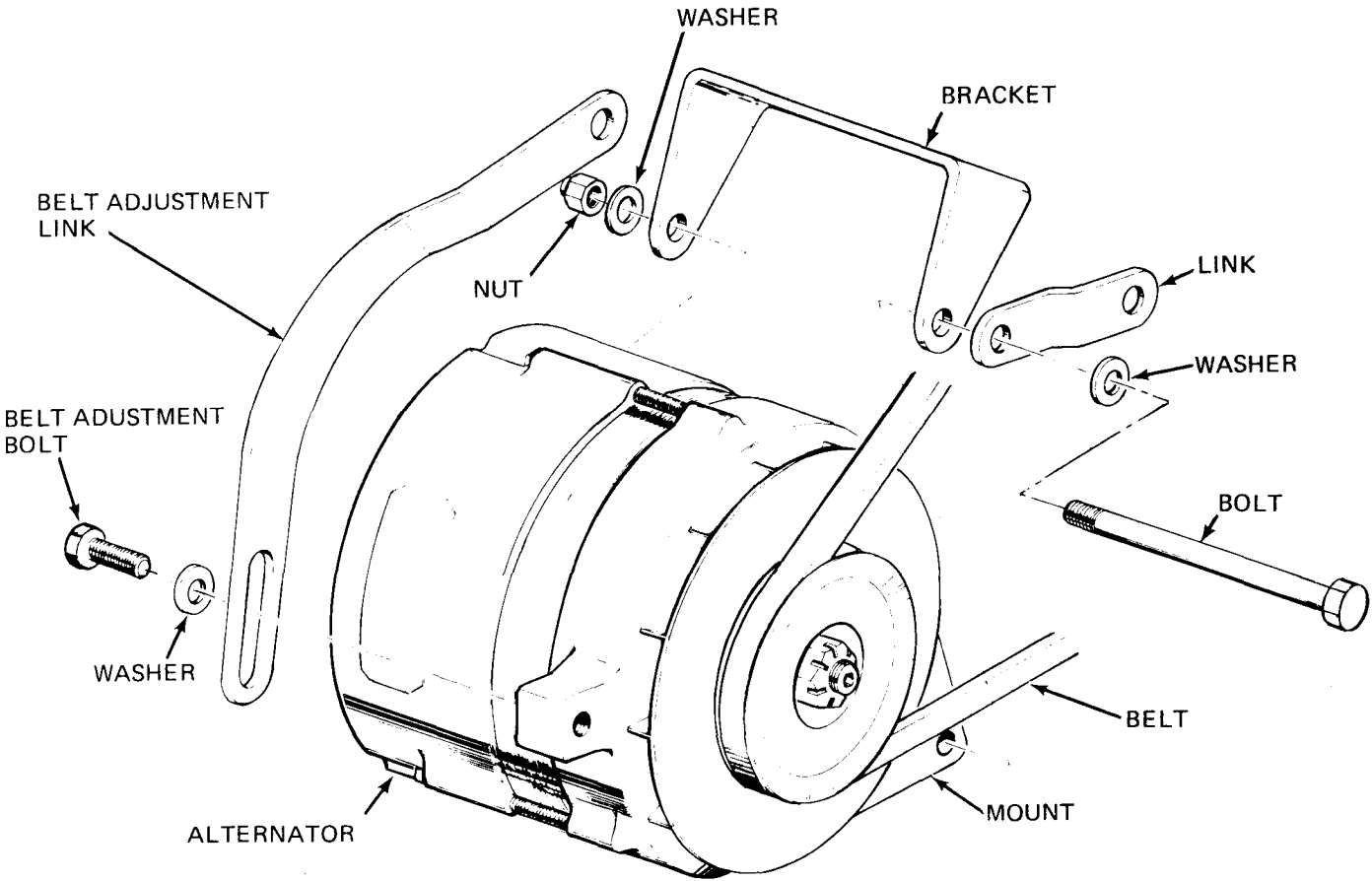

DETAIL A

3036

Alternator - Exploded View
Figure 1

AA-5 SERIES
MAINTENANCE MANUAL

AA-5A 0001 thru 0522
AA-5B 0001 thru 0692

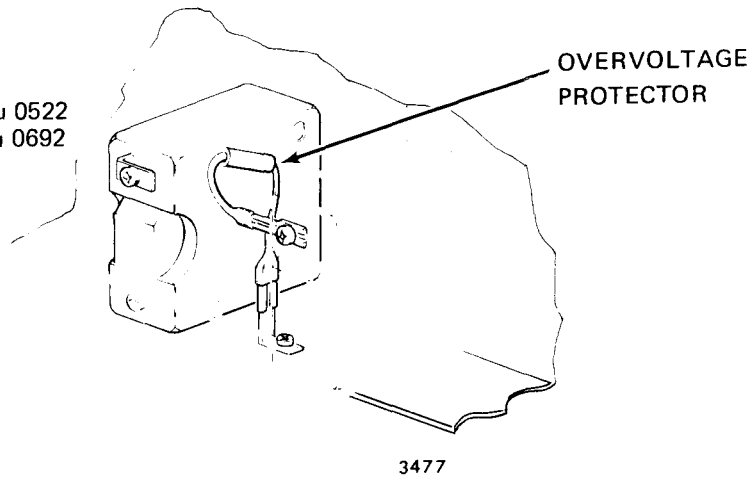

Protection Diode
Figure 2

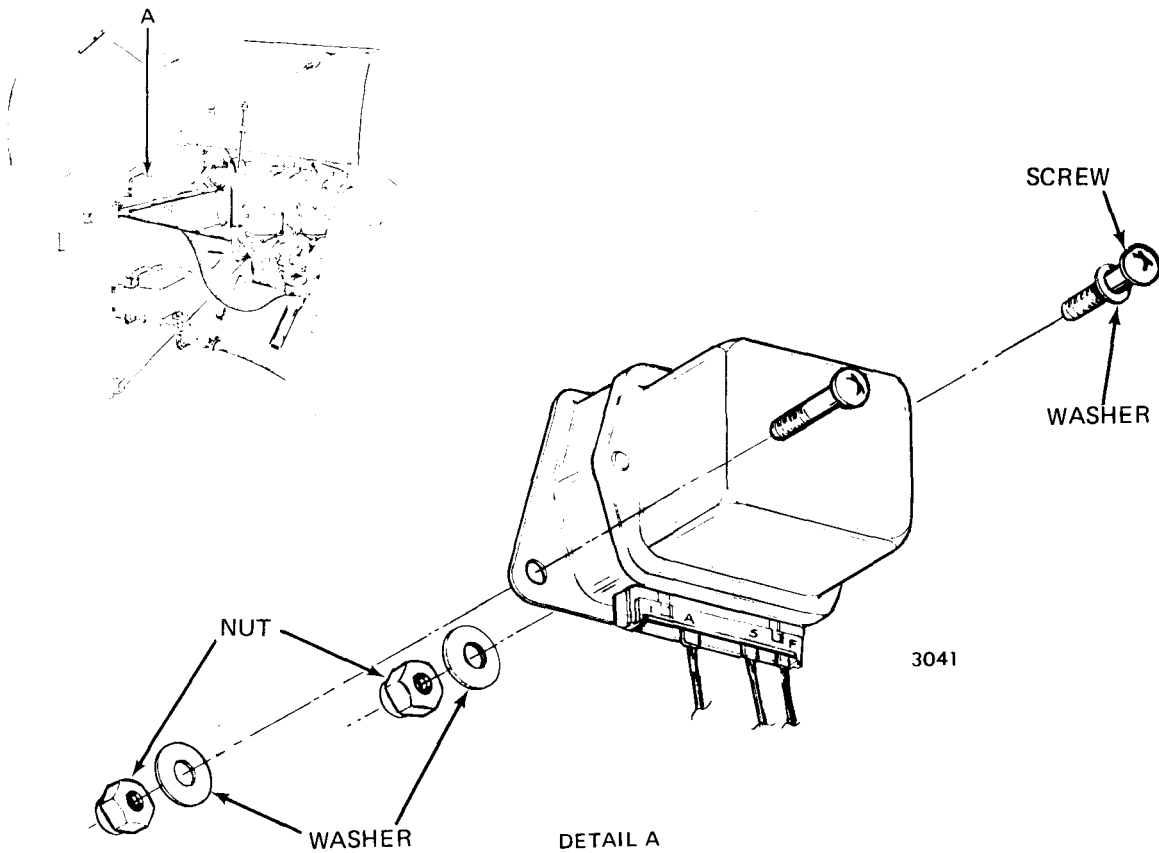

Voltage Regulator - Exploded View
Figure 3

**AA-5 SERIES
MAINTENANCE MANUAL**

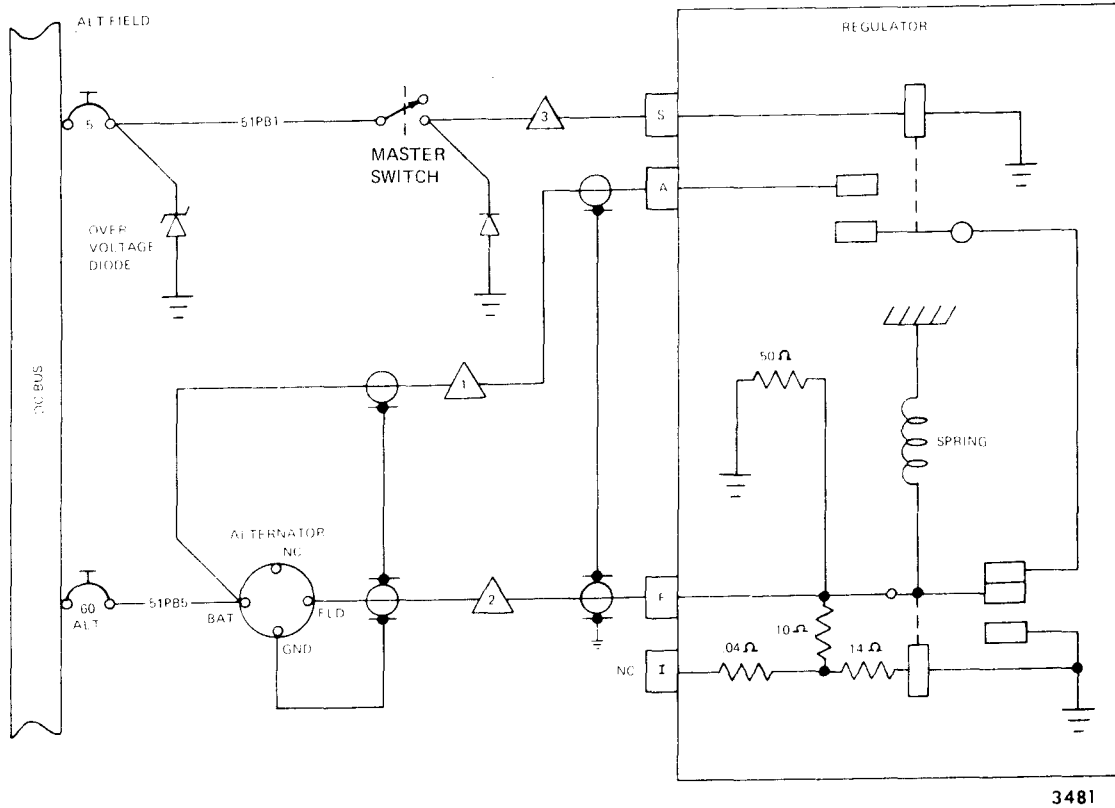

NOTES



AA5-0001 THROUGH AA5-0491, WIRE NO. 5PB6; AA5-0492 AND SUBSEQUENT, AA-5A AND AA-5B, WIRE NO. 5PB8.



AA5-0001 THROUGH AA5-0491, WIRE NO. 5PB7; AA5-0492 AND SUBSEQUENT, AA-5A, AND AA-5B, WIRE NO. 5PB9



AA5-0001 THROUGH AA5-0491, WIRE NO. 5PB2; AA5-0492 AND SUBSEQUENT, AA-5A, AND AA-5B, WIRE NO. 5PB10

Alternator Circuit - Wiring Diagram
Figure 4

**AA-5 SERIES
MAINTENANCE MANUAL**

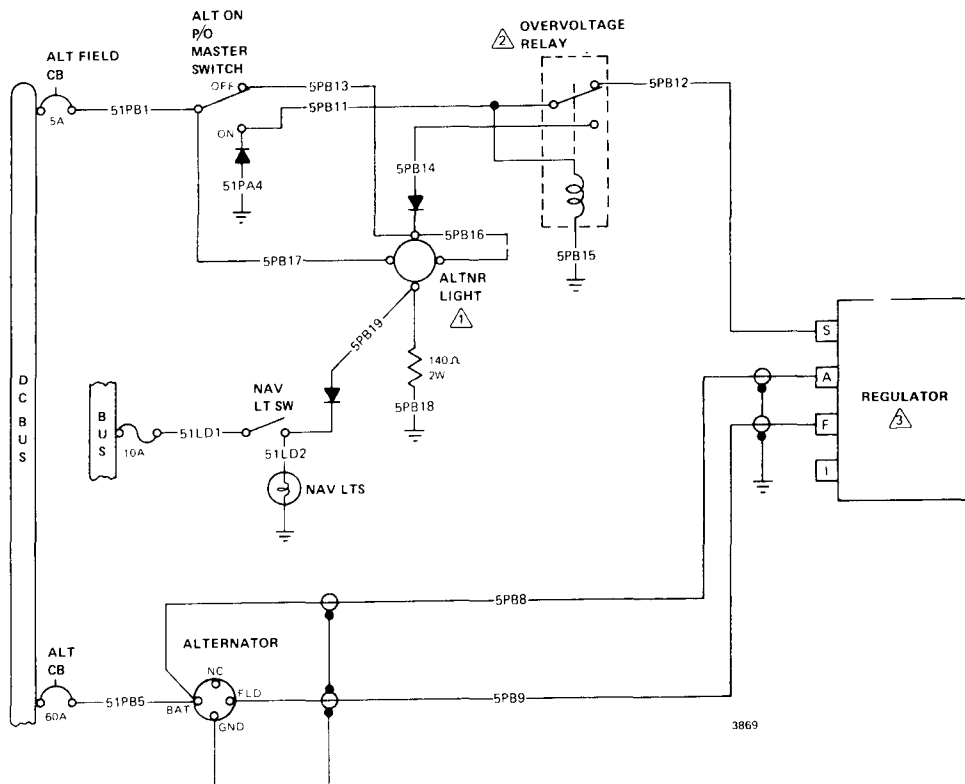

- Located on instrument panel.
- Located on firewall.
- See Figure 4 for diagram

Alternator Circuit — Wiring Diagram
(1978 AA5A-0523 and sub., AA5B-0693 and sub.)
Figure 5

**AA-5 SERIES
MAINTENANCE MANUAL**

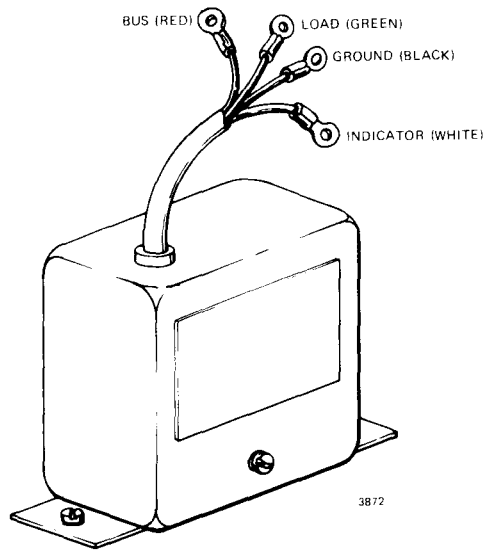

**Overvoltage Relay
Figure 6**

**AA-5 SERIES
MAINTENANCE MANUAL**

ALTERNATOR SYSTEM – TROUBLESHOOTING

| TROUBLE | PROBABLE CAUSE | REMEDY |
|---|---|---|
| Alternator overcharges battery; battery uses excessive water. | Regulator faulty. | Check bus voltage with engine running. voltage should agree with voltage vs temperature chart. Observe aircraft ammeter. Ammeter should indicate near zero after ten minutes of engine operation. Replace voltage regulator if defective. |
| ALT FIELD circuit breaker trips. | Circuit shorted to ground through overvoltage diode. (AA5-603 and sub., AA5A-0001 through 0692) | Check overvoltage diode by measuring its resistance in each direction. The front-to-back resistance shall be 10 to 1. Replace if defective. |
| | Circuit shorted through diode on Master switch. | Check diode by measuring its resistance in each direction. The front-to-back resistance shall be 10 to 1. Replace if defective. |
| | Circuit shorted in wiring. | Disconnect lead from pin S of regulator, and reset circuit breaker. If circuit breaker trips, check wiring. Repair as required. If breaker does not trip, replace regulator. Reconnect lead to pin S of regulator. Set MASTER switch to ON and check for 12V at pin S of regulator. Repair wiring if no voltage is present. |
| ALT circuit breaker trips. | Short circuit in wiring. | Disconnect lead from BAT post of alternator, and reset ALT circuit breaker. If circuit breaker trips, check wiring between alternator and circuit breaker. |
| | Short circuit in alternator. | Reconnect lead to BAT post of alternator. Disconnect leads from A and F terminals of regulator. Insulate disconnected leads. <u>WARNING: ENSURE THAT MAGNETO SWITCH IS OFF WHEN TURNING PROPELLER.</u> |

**AA-5 SERIES
MAINTENANCE MANUAL**

| TROUBLE | PROBABLE CAUSE | REMEDY |
|---|--|---|
| ALT circuit breaker trips (Continued) | | Rotate propeller by hand to rotate alternator through 360 degrees of travel. If circuit breaker trips replace alternator. |
| | Defective regulator. | Reconnect leads at A and F of regulator. Reset circuit breaker. If breaker trips, replace regulator. |
| Alternator will not keep battery charged. | Battery malfunction. | 1. Start engine and adjust for 1500 RPM. Ammeter should indicate a heavy charge rate with all electrical equipment turned off. Rate should taper off in 1 to 3 minutes. A voltage check at the bus should indicate a reading consistent with the voltage vs temperature chart. (See Voltage Regulator paragraph.) If charge rate tapers off very quickly and voltage is normal, check battery for malfunction. If ammeter shows a low charge rate or any discharge rate, and voltage is low, proceed to Step 3. |
| | Defective overvoltage relay. (1978 Models AA5A-0523 and sub. and AA5B-0693 and sub.) | 2. Check voltage at "S" terminal of regulator with Master switch closed. Meter should indicate bus voltage. If voltage is not present, check overvoltage relay. Check voltage at battery terminal of relay. If voltage is present, replace relay. |
| | Regulator faulty. | 3. Remove "A" and "F" terminals from regulator and start engine. Momentarily jump the "A+" and "F" terminals together on the plug. Aircraft ammeter should show heavy rate of charge. If heavy charge rate is observed, replace regulator. If heavy charge rate is not observed, proceed to Step 5. |
| | Defective wiring regulator to alternator. | 4. Check resistance from "F" terminal of voltage regulator to FLD terminal on alternator. Normal indication is a very low resistance. If reading indicates no, or poor continuity, repair or replace wiring from regulator to alternator. |

AA-5 SERIES
MAINTENANCE MANUAL

| TROUBLE | PROBABLE CAUSE | REMEDY |
|---------|-----------------------|--|
| | Defective alternator. | 5. Check resistance from "F" terminal of alternator to alternator case. Normal indication is 3 - 4 ohms. If resistance is high or low, repair or replace alternator. |

**AA-5 SERIES
MAINTENANCE MANUAL**

ALTERNATOR SYSTEM — MAINTENANCE PRACTICES

1. Alternator Removal/Installation (See Figure 1.)

A. Alternator Removal

- (1) Remove upper and lower cowling. The propeller and forward cowl must also be removed.
- (2) On pre 1975 models, disconnect the heater inlet hose from forward engine baffle to provide access to the alternator.
- (3) Disconnect the ground (negative) cable from the battery terminal. Pull cable clear of battery and battery box. (See Battery removal — Steps 2 through 4).
- (4) Cut the safety wire and remove the bolt attaching the alternator to the adjustment link.
- (5) Remove the nut from the support bolt and slide the main alternator support bolt forward out of the alternator from its mount, at the same time removing the drive belt.
- (6) Lower alternator and gain access to the leads. Remove and identify leads from alternator.
- (7) Remove the alternator.

NOTE: Service work performed on the alternator should be in accordance with any manuals or bulletins published by the alternator manufacturers.

B. Alternator Installation

CAUTION: ENSURE GROUND (NEGATIVE) CABLE IS DISCONNECTED AND CLEAR OF BATTERY.

NOTE: When a new belt has been installed, recheck the belt tension within 10 to 20 hours operation.

- (1) Place alternator near mount and connect leads to alternator.
- (2) Slide alternator into mount, at same time place belt on pulley of alternator.
- (3) Slide main alternator support bolt toward firewall and replace nut.
- (4) Replace bolt attaching the alternator to the adjustment link. Adjust the belt tension to yield a 3/8 inch deflection at the center of the belt when applying a pressure equivalent to 12 pounds.
- (5) Safety wire bolt attaching the alternator to the adjustment link.
- (6) Connect ground (negative) cable to the battery (see Battery Installation Steps 3 through 6).
- (7) On pre 1975 models, connect the heater inlet hose to the forward engine baffle.
- (8) Replace upper and lower cowling.
- (9) Perform operational check.

2. Alternator Overvoltage Protection Diode — Replacement

A. Diode Replacement

- (1) Disconnect the ground (negative) cable from the battery terminal. Pull cable clear of battery and battery box. (See Battery Removal Steps 1 through 4.)
- (2) Locate diode on reverse side of circuit breaker panel and replace.
- (3) Connect the ground (negative) cable to battery terminal (see Battery Installation).
- (4) Perform an operational check, per Operational Check.

3. Alternator Overvoltage Protection Relay — Replacement (See Figure 6.)

A. Relay Replacement

- (1) Disconnect ground (negative) cable from battery terminal. Pull cable clear of battery and battery box. (See Battery Removal.)
- (2) Locate overvoltage relay behind instrument panel on right side of firewall.
- (3) Disconnect the leads from the relay. Tag each lead to aid in reinstallation of relay.
- (4) Remove the relay attaching hardware.
- (5) Replace the relay and secure with attaching hardware.
- (6) Reconnect the leads to the relay.
- (7) Connect negative cable to battery. (See Battery Installation.)

4. Voltage Regulator Removal/Installation (See Figure 3.)

A. Regulator Removal

NOTE: The voltage regulator is a sealed unit; therefore, no field adjustments are possible.

- (1) Open right half upper cowl.
- (2) Disconnect ground (negative cable from battery terminal). Pull cable clear of battery and battery box. (See Battery Removal.)
- (3) Disconnect and identify leads from voltage regulator.
- (4) Remove the attaching hardware and remove voltage regulator from firewall.

B. Regulator Installation

NOTE: Ensure that the connections for grounding the alternator, wiring shields and the base of the regulator are clean before installation. This will eliminate the possibility of poor voltage regulator operation and/or excessive radio noise.

- (1) Place regulator against firewall and install attaching hardware.

CAUTION: BEFORE CONNECTING WIRES TO VOLTAGE REGULATOR, ENSURE NEGATIVE CABLE IS DISCONNECTED FROM BATTERY.

- (2) Connect leads to voltage regulator.
- (3) Connect negative cable to battery. (See Battery Installation.)
- (4) Perform operational check, per Operational Check.

5. Operational Check of Alternator

WARNING: BEFORE STARTING ENGINE, BE SURE PROPELLER AREA IS CLEAR.

A. Operational Check

- (1) Start engine in accordance with the Owner's Manual or Pilot's Operating Handbook. Set engine at 1500 rpm.
- (2) Ammeter should indicate a heavy charge rate (positive) with all electrical equipment off.
- (3) Observe that charge rate (positive) tapers off in 1 – 3 minutes.
- (4) Turn on flashing beacon. Ammeter should still show a charge rate (positive).
- (5) Turn off flashing beacon.
- (6) Shut down engine in accordance with the Owner's Manual or Pilot's Operating Handbook.

AA-5 SERIES
MAINTENANCE MANUAL

EXTERNAL POWER — DESCRIPTION/OPERATION

1. General

A ground service receptacle is offered as optional equipment to provide a means of attaching an external power source for cold weather starting or when performing lengthy electrical maintenance.

When external power source is attached, power goes through the ammeter to the bus. The master switch should be placed in the OFF position, when external power is applied.

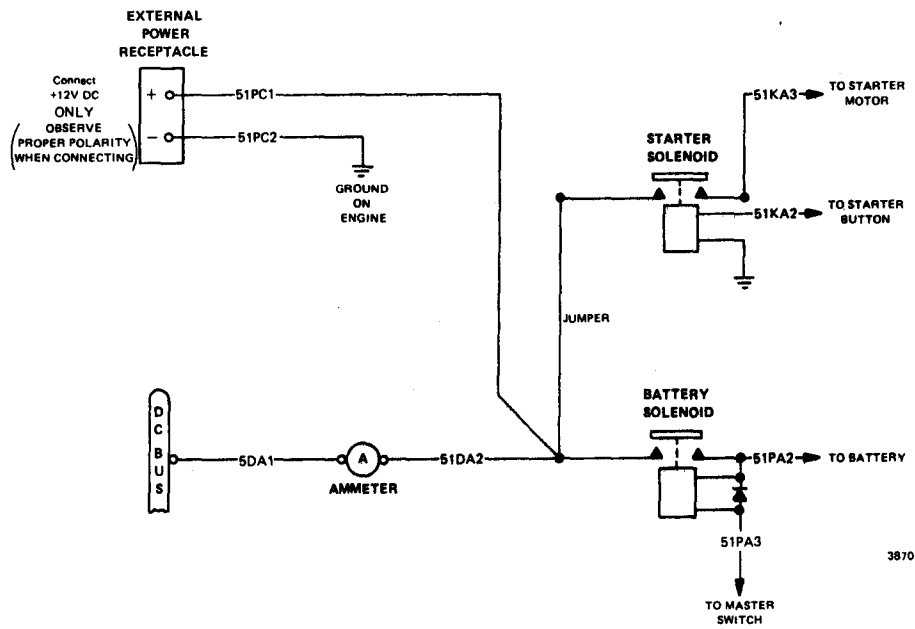

External Power Circuit
Figure 1

EXTERNAL POWER RECEPTACLE – MAINTENANCE PRACTICES

1. External Power Receptacle Removal/Installation (See Figure 201)

A. External Power Receptacle Removal

- (1) Remove upper and lower cowl.
- (2) Disconnect ground (negative) cable from the battery terminal. (See Battery Removal.)
- (3) Remove cable attaching hardware and remove cables.
- (4) Remove receptacle attaching hardware and remove receptacle.

B. External Power Receptacle Installation

CAUTION: ENSURE GROUND (NEGATIVE) CABLE IS CLEAR OF BATTERY TERMINAL.

- (1) Replace receptacle and attaching hardware.
- (2) Replace cables and attaching hardware. Place rubber insulator over positive terminal.
- (3) Connect ground (negative) cable to battery terminal. (See Battery Installation.)
- (4) Replace upper and lower cowl.

AA-5 SERIES
MAINTENANCE MANUAL

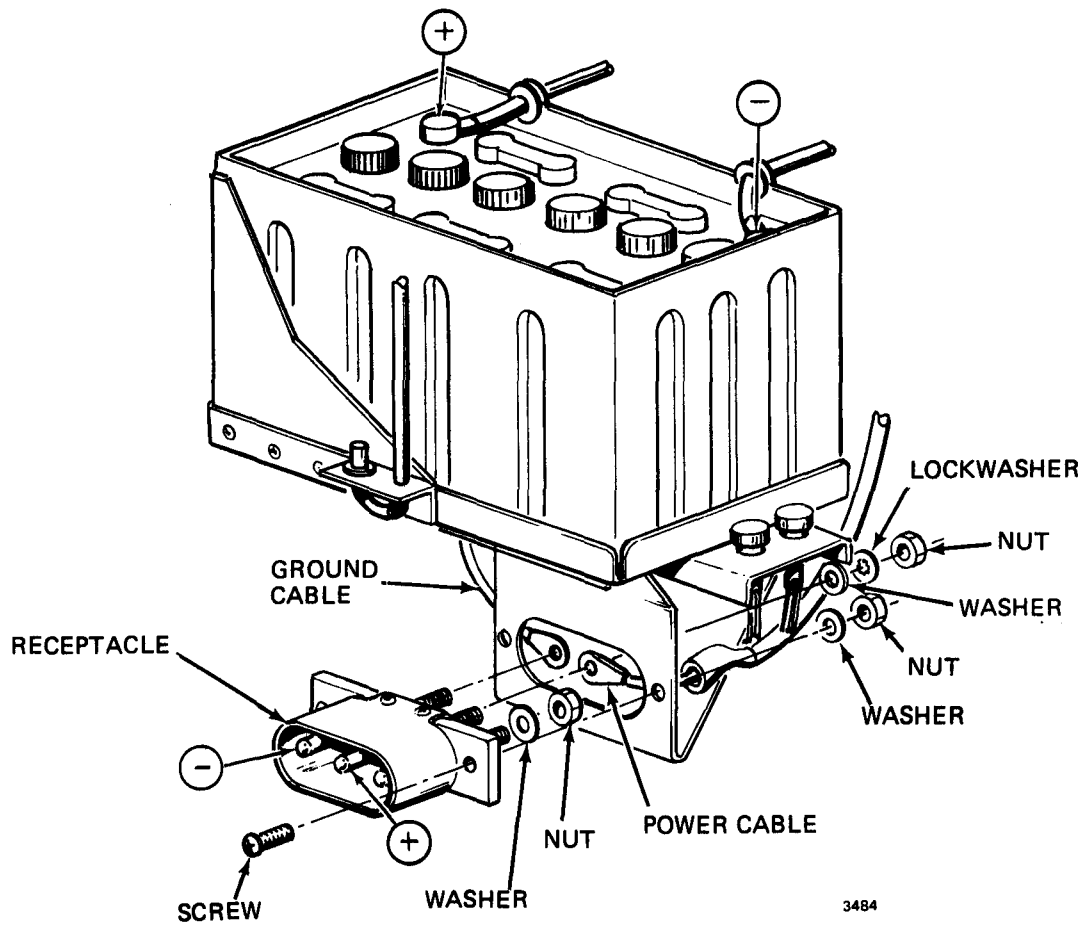

External Power Receptacle
Figure 201

CHAPTER 25
EQUIPMENT AND FURNISHINGS

TABLE OF CONTENTS

| <u>NUMBER</u> | | <u>PAGE</u> |
|---------------|--|-------------|
| 25-1-0 | SEATS | |
| | Description/Operation | 1 |
| | Front Seats | 1 |
| | Rear Seats | 1 |
| | Maintenance Practices | 201 |
| | Front Seat Removal/Installation | 201 |
| | Rear Seat Removal/Installation | 201 |
| 25-2-0 | SAFETY BELTS | |
| | Description/Operation | 1 |
| | General | 1 |
| | Shoulder Harnesses | 1 |
| | Lap Belts | 1 |
| | Maintenance Practices | 201 |
| | Rear Seat Shoulder Harness Removal/Installation | 201 |
| | Front Seat Shoulder Harness Removal/Installation | 201 |
| | Rear Seat Inner Lap Belt Removal/Installation | 201 |
| | Front Seat Inner and Outer Lap Belt Removal/Installation | 202 |
| 25-3-0 | BAGGAGE STRAP ASSEMBLIES | |
| | Description | 1 |
| | General | 1 |
| | Maintenance Practices | 201 |

AA-5 SERIES
MAINTENANCE MANUAL

| <u>NUMBER</u> | | <u>PAGE</u> |
|---------------|--|-------------|
| | Baggage Strap Assembly Removal/Installation | 201 |
| 25-4-0 | CONSOLE ASSEMBLY | |
| | Description | 1 |
| | General | 1 |
| | Maintenance Practices | 201 |
| | Console Assembly Removal/Installation | 201 |
| 25-5-0 | CANOPY AND AFT FUSELAGE INNER TRIM PANELING AND AFT FUSELAGE MOULDING | |
| | Description | 1 |
| | General | 1 |
| | Maintenance Practices | 201 |
| | Canopy Inner Trim Paneling Removal/Installation | 201 |
| | Aft Fuselage Moulding Removal/Installation | 201 |
| | Aft Fuselage Inner Trim Paneling Removal/Installation | 201 |
| 25-6-0 | MISCELLANEOUS FURNISHINGS | |
| | Description | 1 |
| | Carpeting | 1 |
| | Panel Upholstery | 1 |
| | Hatshelf | 1 |
| | Armrests | 1 |
| | Glareshield and Deck Assemblies | 1 |
| | Headliners | 1 |
| | Sun Visor Assembly | 1 |
| | Map Lights | 1 |
| | Fire Extinguisher | 1 |
| | Storage Box — Approach Plates and Owners Manual | 2 |

**AA-5 SERIES
MAINTENANCE MANUAL**

NUMBER

PAGE

25-7-0

INTERIOR CARE

Maintenance Practices

201

Cleaning

201

SEATS — DESCRIPTION/OPERATION

1. General

The seats for AA-5, AA-5A, and AA-5B model aircraft consist of two bucket type seats in the forward compartment and a straight double seat in the rear compartment.

2. Front Seats

The front seats in the AA-5, the AA-5A, and the AA-5B models are horizontally adjustable bucket seats (see Figure 1). Covering for the seats consists of a vinyl fabric combination.

A spring-loaded lever is located on the outboard side of each seat, just below the front portion of the seat cushion. This adjustment lever releases the seat to move forward or aft along the guide track. Detents along the inside and outside track are engaged to lock the seat in place.

The seat backs pull forward to allow entry to the rear seat area or to allow access to bottom cushion snaps, which secure the bottom cushion to the seat pan.

3. Rear Seat

The rear seat in the AA-5, the AA-5A, and the AA-5B models is a straight seat with covering consisting a vinyl/carpet fabric combination (see Figure 2). When the front seats are moved all the way forward, the rear seat bottom may be folded forward, providing access to the flap actuator and control surface rigging turnbuckles.

With the rear seat bottom folded forward, the rear seat back may be folded forward by: first, unsnapping and removing the seat back cushions; and second, pulling up on the spring-loaded latches on each side of the fuselage behind the rear seat. These latches release the seat back to be folded forward and down. The rear seat back in this stowed position provides a large cargo area.

AA-5 SERIES
MAINTENANCE MANUAL

1978 CUSHION

1977 CUSHION

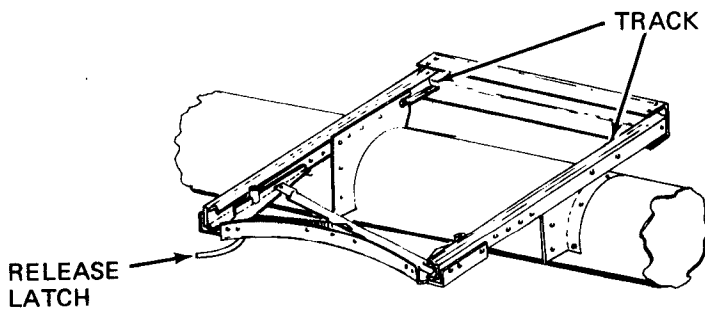
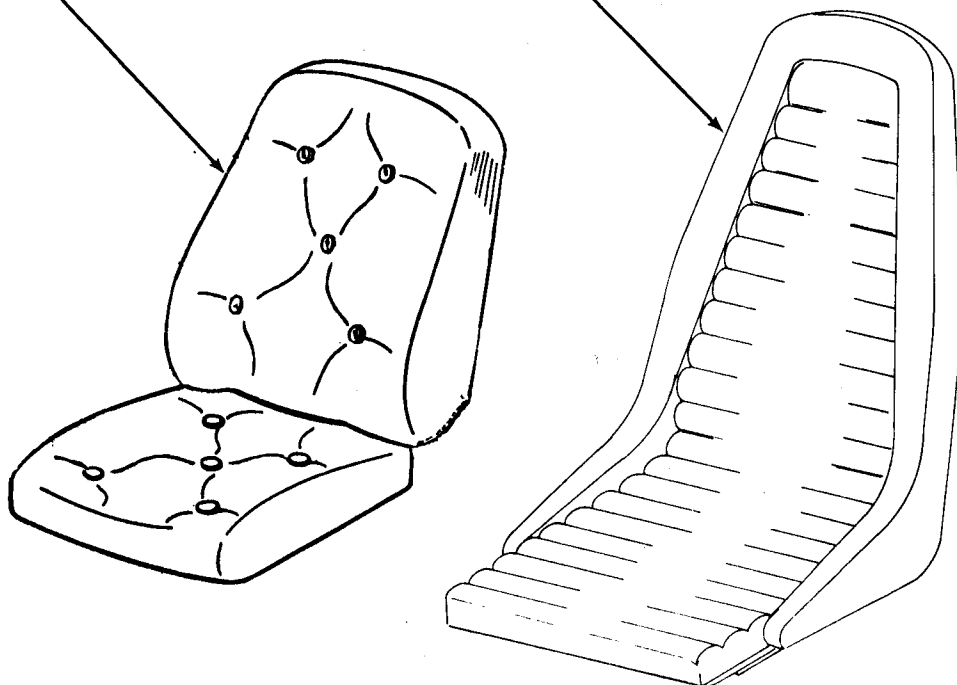

3172

Front Seat
Figure 1

**AA-5 SERIES
MAINTENANCE MANUAL**

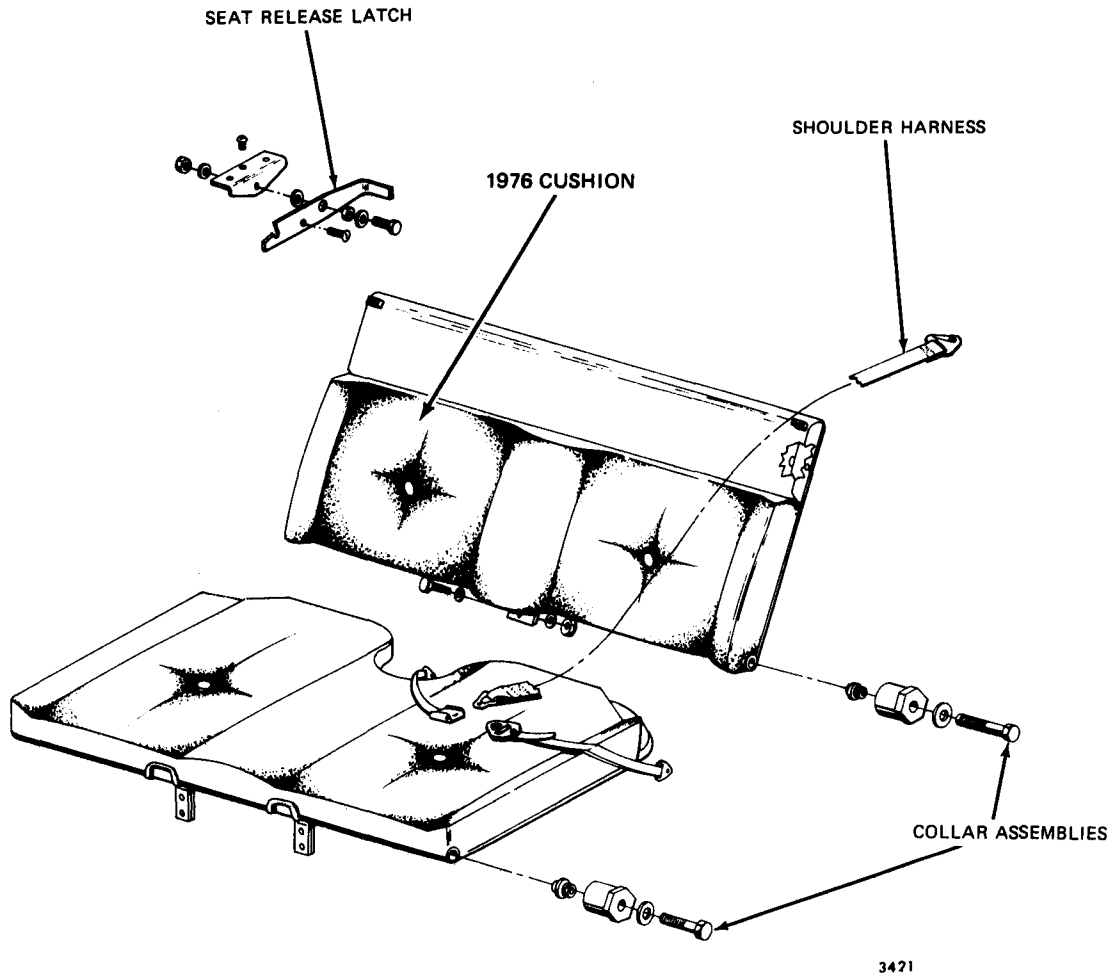

**Rear Seat (Typical)
Figure 2**

SEATS — MAINTENANCE PRACTICES

1. Front Seat Removal/Installation

A. Front Seat Removal

- (1) Locate mounting brackets beneath seat assembly.
- (2) Remove screws attaching mounting brackets to inner seat tracks.
- (3) Slide the seat aft. As the spacers on the inner track slide out of the slots at the rear of the mounting brackets, lift the seat out of the aircraft.

NOTE: Front seat removal does not require removal of the front seat mounting brackets. If they are being removed, however, exercise caution in removing the bolts to prevent pulling rivnuts loose. Aircraft may have either LOCTITE applied to the bolt threads to prevent loosening or may have self-locking bolts. After the bolts are removed from the mounting bracket, remove the seat with the mounting bracket attached to the seat tracks.

B. Front Seat Installation

- (1) Slide the spacers on the inner tracks into the slots at the rear of the mounting brackets.
- (2) Install screws attaching mounting brackets to inner seat tracks.

2. Rear Seat Removal/Installation

A. Seat Back Removal

- (1) Slide front seats as far forward as possible.
- (2) Fold rear seat bottoms forward.
- (3) Unsnap seat back cushions and remove.
- (4) Remove screws from ring and clip assembly located on floor behind rear seat back.
- (5) Locate support at the bottom center portion of the seat back and remove bolt from support.
- (6) Remove attaching bolts from collar assemblies located at the hinge points on each side of the seat back and lift seat back out.

NOTE: It may be necessary to hold the collar assembly with a 7/8 inch open-end wrench while removing the attaching bolts.

B. Seat Bottom Removal

- (1) Fold seat bottom back to the sitting position.
- (2) Locate seat bottom supports on each side of the rear seat console. Remove bolts from supports.
- (3) Remove attaching bolts from collar assemblies located at the hinge points on each side of the seat bottom and lift seat bottom out.

NOTE: It may be necessary to hold the collar assembly with a 7/8 inch open-end wrench while removing the attaching bolts.

C. Rear Seat Installation

(1) Seat Bottom Installation

- (a) Slide front seats as far forward as possible.
- (b) Align collar assemblies on each side of seat bottom with hinge holes in support bracket mounted to fuselage floor.
- (c) Install bolts to the collar assemblies securing the seat bottom to the support bracket.

NOTE: It may be necessary to hold the collar assembly with a 7/8 inch open-end wrench while installing the attaching bolts.

- (d) Secure seat bottom supports on each side of rear seat console to fuselage floor structures.
- (e) Swing seat bottom forward and aft several times to ensure easy movement at hinge points.

(2) Seat Back Installation

- (a) Fold rear seat bottom forward.
- (b) Align collar assemblies on each side of seat back with hinge holes in support bracket mounted to fuselage floor.
- (c) Install bolts to the collar assemblies securing the seat bottom to the support bracket.

NOTE: It may be necessary to hold the collar assembly with a 7/8 inch open-end wrench while installing the attaching bolts.

- (d) At bottom center portion of seat back, secure seat back support to fuselage floor structure.
- (e) Install screws to ring and clip assembly securing support to floor behind seat back.
- (f) Swing seat back forward and aft several times to ensure easy movement at hinge points.
- (g) Snap in cushions to seat back.

SAFETY BELTS — DESCRIPTION/OPERATION

1. General

The seat safety belts for the AA-5, AA-5A, and the AA-5B consist of four lap straps and four shoulder harnesses. (See Figure 1.) The end fitting on each shoulder harness has a slit-opening through which the lap strap end fitting passes and engages the buckle receptacle. The lap strap and the shoulder harness may be lengthened or shortened by means of an adjustment slide buckle.

2. Shoulder Harnesses

The rear seat shoulder harnesses are anchored to mounting plates located on the fuselage side walls just aft of the baggage compartment. The front seat shoulder harnesses are anchored to mounting plates located on the fuselage side walls just aft of the front seats. When not in use, the shoulder harness straps are held in place by clips mounted on the fuselage side walls.

3. Lap Belts

The rear seat inner lap belt assemblies are anchored to a bracket mounted to the fuselage assembly beneath the center bottom portion of the seat back. The rear seat outer lap belt assemblies are anchored to brackets mounted to the fuselage floor on the left and right outboard sides of the rear seat. The inner and outer lap belt assemblies for the front seats are anchored to brackets which are mounted to the floor and located to the left and right sides of each front seat assembly.

AA-5 SERIES
MAINTENANCE MANUAL

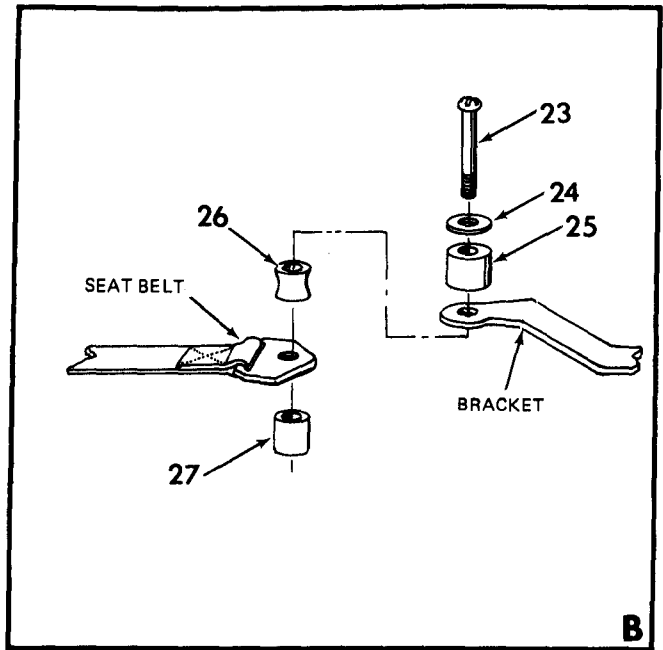
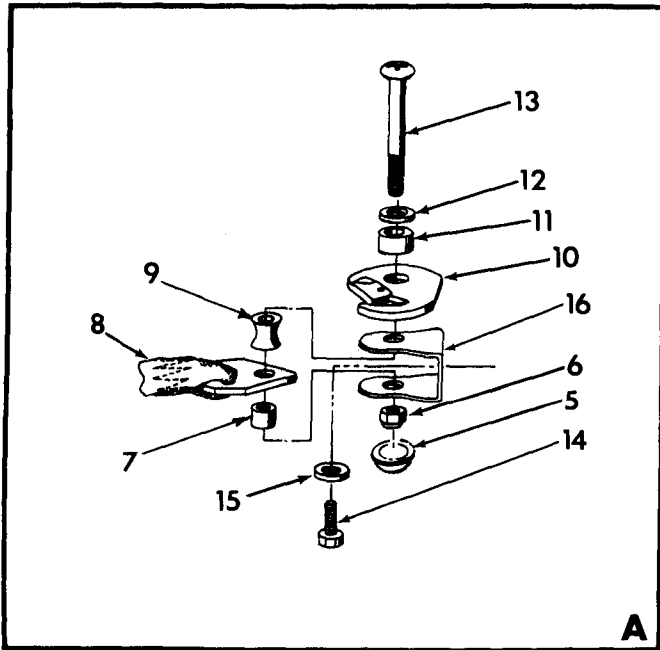
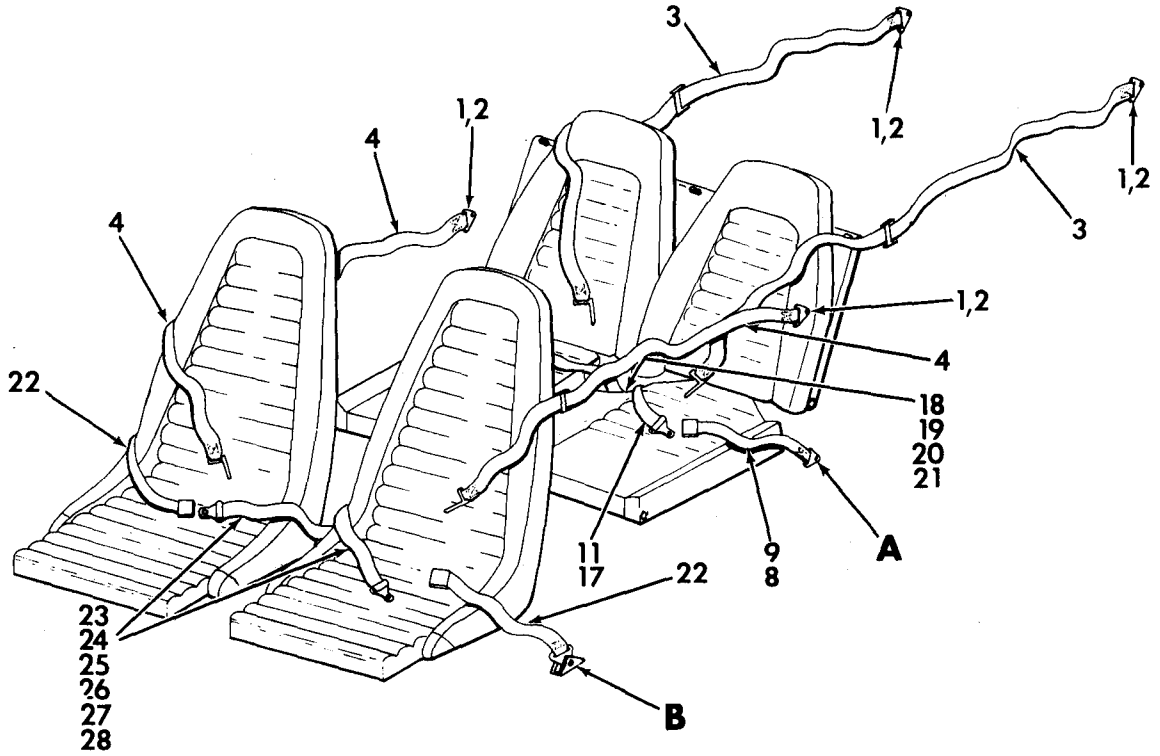

Lap Belts and Shoulder Harnesses
Figure 1

SAFETY BELTS — MAINTENANCE PRACTICES

1. Rear Seat Shoulder Harness Removal/Installation (See Figure 1.)
 - A. Rear Seat Shoulder Harness Removal
 - (1) Locate point at which rear seat shoulder harness is attached to fuselage side wall just aft of the baggage compartment.
 - (2) Remove screw (1) and spacer (2) securing harness end fitting to mounting plate. Remove rear seat shoulder harness (3).
 - B. Rear Seat Shoulder Harness Installation
 - (1) Align hole in harness end fitting with hole in mounting plate.
 - (2) Secure harness (3) end fitting to mounting plate with spacer (2) and screw (1).
2. Front Seat Shoulder Harness Removal/Installation (See Figure 1.)
 - A. Front Seat Shoulder Harness Removal
 - (1) Locate point at which front seat shoulder harness (4) is attached to fuselage side wall just aft of the front seats.
 - (2) Remove screw (1) and spacer (2) securing harness end fitting to mounting plate. Remove harness (4).
 - B. Front Seat Shoulder Harness Installation
 - (1) Align hole in harness (4) end fitting with hole in mounting plate.
 - (2) Secure harness end fitting to mounting plate with spacer (2) and screw (1).
3. Rear Seat Outer Lap Belts Removal/Installation (See Figure 1.)
 - A. Rear Seat Outer Lap Belts Removal
 - (1) Locate point at which rear seat outer lap belts are attached to brackets mounted to the fuselage floor on the left and right outboard sides of the rear seat.
 - (2) Remove plug (5), nut (6), spacer (7), belt end (8), spacer (9), latch hook (10), spacer (11), washer (12), and screw (13). If necessary to remove bracket (16), remove screw (14) and washer (15). Plug (5) is used on AA5-0406 and subsequent and AA5B-0001 and subsequent.
 - B. Rear Seat Outer Lap Belts Installation
 - (1) If bracket (16) was removed, reinstall with screw (14) and washer (15).
 - (2) Secure lap belt end fitting to bracket, aligning hardware in the following order: screw, washer, spacer, cargo latch hook (on aircraft having this hook installed), bracket, spacer, lap belt end fitting, spacer, bracket nut, and plug (only on AA5-0406 and subsequent; and AA5B-0001 and subsequent).
4. Rear Seat Inner Lap Belts Removal/Installation (See Figure 1.)
 - A. Rear Seat Inner Lap Belt Removal
 - (1) Fold rear seat bottom forward and unsnap and remove seat back cushions.
 - (2) Locate bracket mounted to the fuselage assembly beneath the center bottom portion of the seat back. Locate point at which rear seat inner lap belts (17) are attached to bracket.
 - (3) Remove nut (18), washer (19), spacer (20), and bolt (21). Remove inner lap belts (17).

B. Rear Seat Inner Lap Belt Installation

- (1) Align holes in lap belt end fittings with holes in bracket.
- (2) Secure lap belt end fittings to bracket, aligning hardware in the following order: bolt, bracket, right lap belt end fitting, spacer, left lap belt end fitting, bracket, washer, and nut.

5. Front Seat Inner and Outer Lap Belt Removal/Installation (See Figure 1.)

A. Front Seat and Outer Lap Belt Removal

- (1) Locate brackets which are mounted to the floor to the left and right sides of each front seat assembly, Locate point at which front seat lap belts (22 and 28) are attached to brackets.
- (2) Remove screw (23), washer (24), spacers (25, 26, and 27). Remove sap belts (22 and 28).

B. Front Seat Inner and Outer Lap Belt Installation

- (1) Place end fittings of lap belts (22) and (28) in position and install spacer (27), spacers (26 and 25), washer (24), and screw (23).

BAGGAGE STRAP ASSEMBLIES - DESCRIPTION

1. General

The baggage strapping consists of four (4) strap assemblies, each anchored to the corner of the baggage compartment floor (see Figure 201).

The straps are normally arranged in a crossed position for securing baggage. Each of the two (2) straps directly behind the rear seat is equipped with a buckle which accepts and clamps the strap anchored at the diagonally opposite corner of the baggage floor.

BAGGAGE STRAP ASSEMBLIES – MAINTENANCE PRACTICES

1. Baggage Strap Assembly Removal/Installation (See Figure 201.)

A. **Baggage Strap Assembly Removal**

- (1) Fold rear seat bottom forward and fold rear seat back down.
- (2) Remove baggage floor carpet.
- (3) Remove inspection cover assembly to gain access to washer and nut for particular strap assembly being removed.
- (4) Remove screw securing strap end fitting to baggage floor. Note the order in which the parts are aligned: screw, washer, bushing, washer and nut.

B. **Baggage Strap Assembly Installation**

- (1) Secure strap end fitting to baggage floor, aligning the hardware in the following order: screw, washer, bushing, washer and nut.
- (2) Install inspection cover assembly.
- (3) Install baggage floor carpeting.

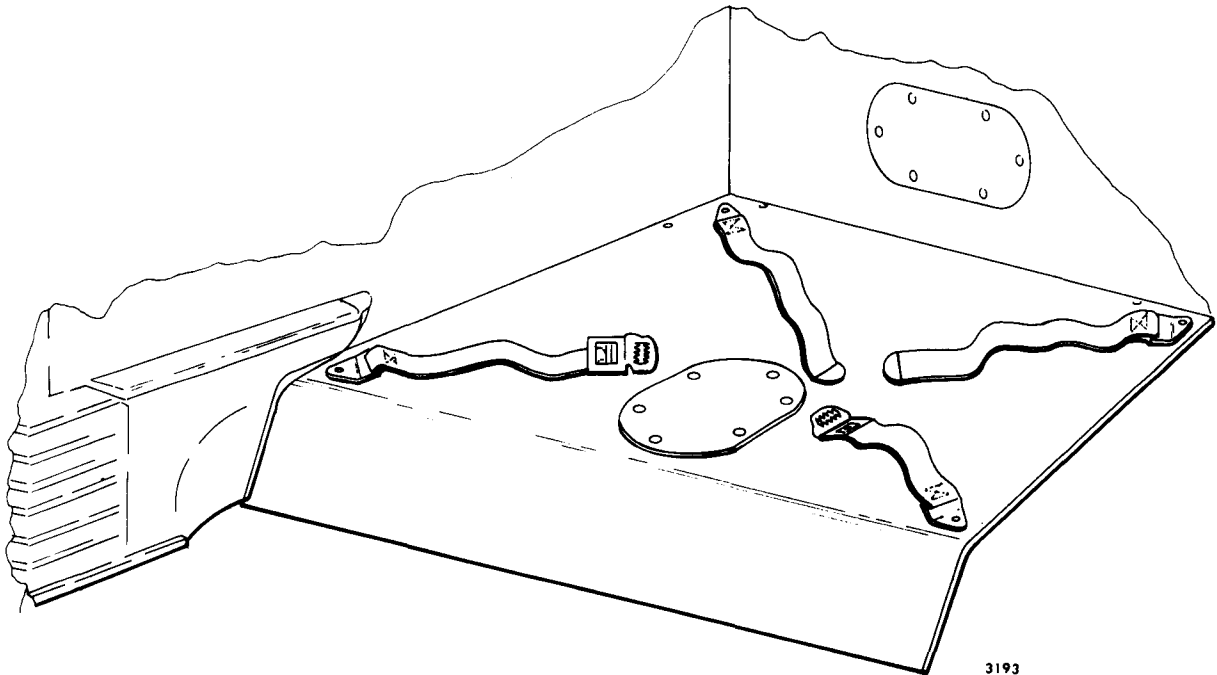

Baggage Strap Assemblies
Figure 201

**AA-5 SERIES
MAINTENANCE MANUAL**

CONSOLE ASSEMBLY - DESCRIPTION

1. General

The console assembly is located between the front seats and consists of forward, top, side and aft Royalite panel sections surrounding the console frames (see Figure 1, Console Assembly). The console assembly contains the fuel gauges, fuel selector valve, removable ash tray, trim wheel, trim indicator, flap switch, flap indicator and pop-out cigarette lighter (see Figure 2, Cigarette Lighter Wiring Schematic). The console assembly also covers the control surface pulley groups in the cabin area.

The console sections can be removed individually or entirely depending on the nature of the repair being performed. Maintenance Practices in the following section presents removal and installation procedures for each console section and the items that can be serviced or inspected with that console section removed.

Limited inspection of components within the console can be accomplished by removing the ash trays and using a hand mirror.

AA-5 SERIES
MAINTENANCE MANUAL

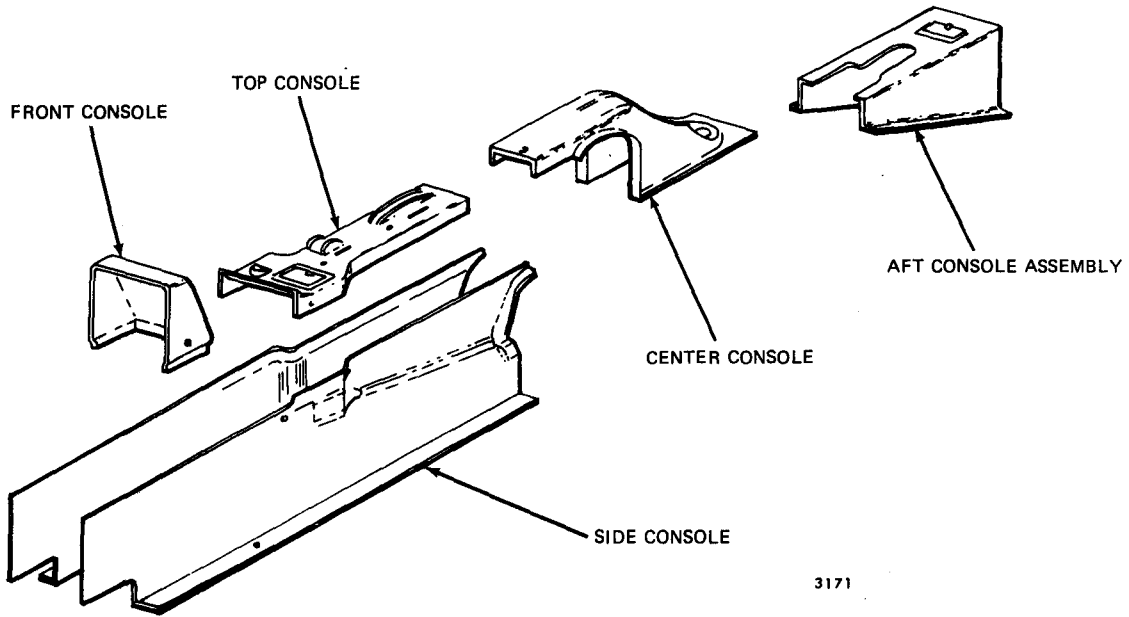

Console Assembly
Figure 1

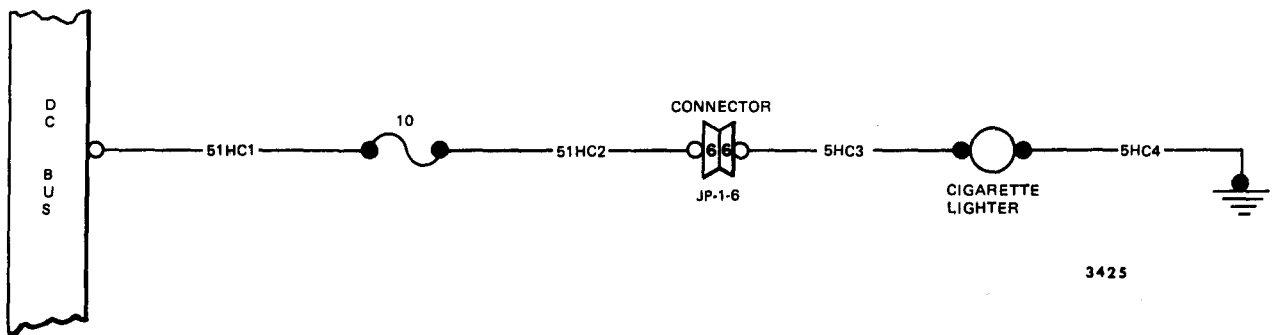

Cigarette Lighter Wiring Schematic
Figure 2

CONSOLE ASSEMBLY – MAINTENANCE PRACTICES

1. Console Assembly Removal/Installation

A. Forward (Front) Console Removal

- (1) Remove fuel selector handle insert to gain access to screw securing handle to handle shaft. Remove screw and lift handle off.
- (2) Remove upper and lower forward console panel screws and remove panel.

B. Top Console Removal

NOTE: Removal of the top console section allows access to trim wheel and flap switch for repair work.

- (1) Remove flap switch handle by rotating it counterclockwise.
- (2) Remove screws securing microphone bracket to console and remove bracket.
- (3) Remove ash tray from console.
- (4) Remove cigarette lighter base from console and disconnect wire from lighter.
- (5) Remove screws around side of top console and remove console.

C. Aft Console Removal

NOTE: Removal of the aft console cover provides access to the aileron and elevator turnbuckles.

- (1) Unsnap or pull Velcro apart on rear floor carpet around console.
- (2) Remove aft console attach screws and remove aft console.

D. Side Console Removal

NOTE: Removal of console side panels provides access for inspection and servicing of the pulley groups, trim wheel and indicator, and flap switch and indicator.

NOTE: Removal of front seats will provide easier access to side console panels.

- (1) Unsnap or pull Velcro apart on floor carpet around console.
- (2) Remove screws securing console panel to floor. If top console has not been removed, also remove screws securing side panel to top console.
- (3) On aircraft having microphone jack on side console, remove mounting nut from jack.
- (4) Remove side console panel. If top console has not been removed, remove the side panel by pulling bottom out and down to disengage the upper edge of panel from under the flange on the top cover.

E. Side Console Installation

NOTE: If top console panel is already installed, be sure the upper edge of side panel is inserted between the metal console frame and the flange on top console panel.

- (1) Install screws securing side panel to the floor and top console.

**AA-5 SERIES
MAINTENANCE MANUAL**

(2) Snap floor carpet to floor.

F. Aft Console Installation

(1) Install screws securing aft console to floor.

(2) Snap floor carpet to floor.

G. Top Console Installation

(1) Align top console panel with metal console frame.

(2) Install screws around side flange of top console.

H. Forward Console Installation

(1) Install upper and lower forward console frame.

(2) Install screw mounting fuel selector handle to handle shaft.

(3) Replace fuel selector handle insert.

CANOPY AND AFT FUSELAGE INNER TRIM PANELING AND
AFT FUSELAGE MOULDING - DESCRIPTION

1. General

The canopy inner paneling and aft fuselage mouldings consist of a thermo-plastic material and serve as trims around the canopy and aft fuselage windows (see Figure 1).

The aft fuselage inner paneling consists of a thermo-plastic material which extends across the lower section of the aft fuselage, including the baggage door.

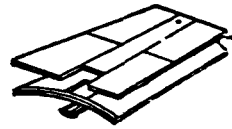

AA5A-0294 AND SUBSEQUENT
AA5B-0413 AND SUBSEQUENT

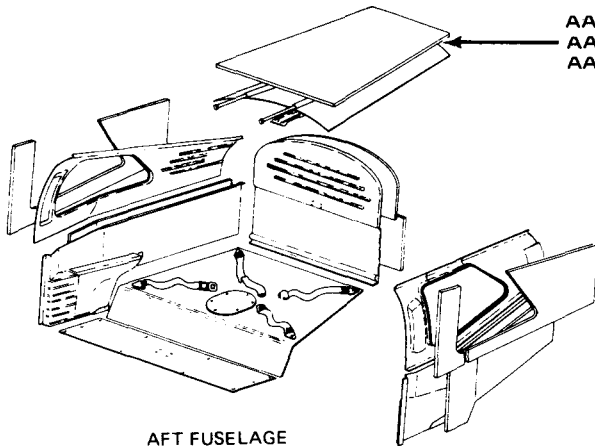

AA5-0001 THRU 0834
AA5A-0001 THRU 0293
AA5B-0001 THRU 0412

AFT FUSELAGE
INNER PANELING

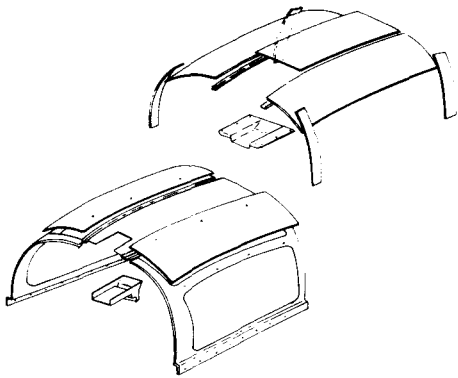

CANOPY INNER
PANELING

3168

Inner Paneling
Figure 1

CANOPY AND AFT FUSELAGE INNER TRIM PANELING AND
AFT FUSELAGE MOULDING — MAINTENANCE PRACTICES

1. Canopy Inner Trim Paneling — Removal/Installation
 - A. Canopy Inner Trim Paneling — Removal
 - (1) Remove canopy. (See Chapter 52.)
 - (2) Drill out three rivets toward top of forward canopy bow.
 - (3) Remove remaining five screws from forward canopy bow.
 - (4) On the outside of the canopy, remove the bottom row of screws.
 - (5) Drill out rivets securing side panel to back flange of canopy and pull panel out.
 - B. Canopy Inner Trim Paneling — Installation
 - (1) If new panel is to be installed, align plastic trim panel to inside of canopy and drill out holes needed for screws and rivets. If required, trim panel for proper fit. Insert panel flange beneath forward canopy bow.
 - (2) Install screws to secure panel to bottom edge of canopy.
 - (3) Install screws to forward canopy bow to secure flange of panel.
 - (4) Install rivets securing flange of panel to top portion of forward canopy bow.
 - (5) Install rivets securing side panel to back flange of canopy.
 - (6) Install canopy. (See Chapter 52.)
2. Aft Fuselage Moulding — Removal/Installation
 - A. Aft Fuselage Moulding — Removal
 - (1) Remove bottom four screws on aft fuselage bow.
 - (2) Remove 12 screws from panel around window edges and pull panel out.
 - B. Aft Fuselage Moulding — Installation
 - (1) If new moulding is to be installed, align moulding to inside of aft fuselage and drill out holes needed for screws. If required, trim panel for proper fit. Insert moulding flange beneath aft fuselage bow.
 - (2) Install screws to aft fuselage bow to secure flange of moulding.
 - (3) Install 12 screws securing moulding to flanges around window edges.
3. Aft Fuselage Inner Trim Paneling — Removal/Installation
 - A. Aft Fuselage Inner Trim Paneling — Removal
 - (1) Remove upholstery side paneling in front seat cabin area by removing screws securing upholstery to fuselage.
 - (2) Fold back seat bottom section forward to gain access to screws securing panel to metal flange. Remove screws.

**AA-5 SERIES
MAINTENANCE MANUAL**

- (3) Remove bolt securing front shoulder harness end fitting to mounting bracket.
- (4) Remove screws attaching air outlet vent to side panel and remove vent.
- (5) At the rear section of aft fuselage paneling, pull panel down and out.
- (6) At forward section of aft fuselage paneling, pull panel from beneath aft fuselage moulding.
- (7) Pull paneling out and up to remove paneling from shoulder harness mounting bracket.
- (8) If baggage door inner panel is to be removed, remove screws attaching panel to baggage door.

B. Aft Fuselage Inner Trim Paneling — Installation

- (1) If new paneling is to be used, drill out holes needed for screws.
- (2) Fit paneling over shoulder harness mounting bracket and under back seat latch.
- (3) Place top edge of paneling beneath aft fuselage moulding.
- (4) Install screws securing air outlet vent to side panel.
- (5) Install bolt securing front shoulder harness end fitting to mounting bracket.
- (6) Install screws securing bottom of panel to metal flange on floor.
- (7) Install screws securing upholstery side paneling to fuselage.
- (8) If baggage door inner panel is to be installed, install screws attaching panel to baggage door.

MISCELLANEOUS FURNISHINGS - DESCRIPTION

1. Carpeting

The flooring in the cabin area and in the baggage compartment is covered with carpeting which is secured to the floor with snap attachments or Velcro allowing easy removal and replacement. The carpeting just below the side trim panels is secured to the forward and aft cover assemblies with an adhesive glue. An adhesive glue application is also used to secure carpeting to the aft console frame. Spots or stains on carpeting may be removed with a household spot remover, used sparingly.

2. Panel Upholstery

The side paneling in the front seat cabin area consists of a vinyl/carpet combination. The paneling is installed to the side fuselage with screws. The vinyl portions of the paneling may be cleaned with a damp cloth. Spots and stains on carpet portions of the paneling may be removed with a household spot remover, used sparingly.

3. Hatshelf

Aircraft AA-5-0406 and subsequent and Aircraft AA-5B-0001 and subsequent are furnished with a hatshelf installation located just aft of the baggage compartment.

4. Armrests

The front seat armrests are located on each fuselage side trim panel. The rear seat armrests are attached to the left and right aft panels.

5. Glareshield and Deck Assemblies

The glareshield and deck assemblies are mounted to the top of the instrument panel and supported by the instrument panel brace and left and right angle structures. The deck assembly houses defroster outlet assemblies and speaker assemblies. The glareshield and deck assemblies may be removed by removing the attaching screws.

6. Headliners

Headliner panels for the canopy section are located on each side of center cover section. These headliner panels are permanently affixed to the canopy. The headliner for the aft fuselage overhead section is attached to metal tubes which are inserted into the frame structures on the front and aft mouldings. The headliner in the aft overhead section may be removed by removing the dome assembly and the outer frame on the front moulding and pulling the tubes from the front and aft frames.

7. Sun Visor Assembly

On Aircraft AA-5A-0001 and subsequent and on Aircraft AA-5B-0111 and subsequent, optional plexi-glass sun visor assemblies are attached to the left and right hand sides of the forward canopy panel. When not in use visors may be folded back to the side of the canopy.

8. Map Lights

See Chapter 33 for Description/Operation of map light assemblies.

AA-5 SERIES
MAINTENANCE MANUAL

9. Fire Extinguisher

A fire extinguisher is available as optional equipment. On some aircraft, the fire extinguisher is installed in a bracket mounted on the seat bottom and some are in a bracket attached to the floor of the aircraft.

10. Storage Box — Approach Plates and Owner's Manual

A storage box is available as optional equipment. The box is a 6 inch by 10 inch box and is installed on the aircraft floor below the front seats. The storage box provides convenient storage for the Pilot's Operating Handbook and approach plates.

INTERIOR CARE - MAINTENANCE PRACTICES

1. Cleaning

Clean the interior regularly with a vacuum cleaner to remove dust and loose dirt from the upholstery and carpet.

CAUTION: THE APPLICATION OF CERTAIN CLEANING AGENTS, PROTECTIVE COATINGS, STAIN REPELLENTS, AND OTHER CHEMICAL COMPOUNDS MAY REDUCE THE FIRE RETARDANT QUALITIES OF INTERIOR FABRICS. CONSULT THE COMPOUND MANUFACTURER BEFORE USE.

If liquid (coffee, etc.) is spilled on the upholstery or carpet, blot it up promptly with cleansing tissue or rags. Continue blotting until no more liquid is taken up. Sticky materials may be scraped up with a dull knife, then cleaned up with a spot remover.

Oily spots may be cleaned with household spot removers, used sparingly. Before using any solvent, read the instructions on the container and test it on an obscure place on the fabric to be cleaned. Never saturate the fabric with a volatile solvent; it may damage the padding and backing materials.

CAUTION: NEVER USE GASOLINE, BENZINE, ALCOHOL, ACETONE, CARBON TETRACHLORIDE, FIRE EXTINGUISHER FLUID, ANTI-ICE FLUID, LACQUER THINNER, OR GLASS CLEANER TO CLEAN PLASTIC. THESE MATERIALS WILL DAMAGE THE PLASTIC AND MAY CAUSE SEVERE CRAZING.

The plastic trim headliner, instrument panel, and control knobs need only be wiped off with a damp cloth. Oil and grease on the control wheel and control knobs can be removed with a cloth moistened with Stoddard solvent.

**AA-5 SERIES
MAINTENANCE MANUAL**

CHAPTER 27
FLIGHT CONTROLS
TABLE OF CONTENTS

| <u>NUMBER</u> | | <u>PAGE</u> |
|----------------------|--|--------------------|
| 27-0 | FLIGHT CONTROLS | |
| | Description/Operation | 1 |
| | General | 1 |
| | Lateral Control System | 1 |
| | Directional Control System | 1 |
| | Longitudinal Control System | 1 |
| | Flap System | 1 |
| | Gust Lock | 1 |
| 27-1-1 | AILERON & TAB | |
| | Description/Operation | 1 |
| | General | 1 |
| | Maintenance Practices | 301 |
| | Servicing | 301 |
| | Lubrication of Aileron Bearings and Control Column | 301 |
| | Removal/Installation | 401 |
| | Aileron and Torque Tube Removal/Installation | 401 |
| | Aileron Bearing Removal/Installation | 401 |
| | Aileron Bearing Wear Limits | 404 |
| | Aileron Cable Removal/Installation | 404 |
| | Control Column Removal/Installation | 406 |
| | Control Column Disassembly/Assembly | 408 |
| | Aileron Removal/Installation | 413 |
| | Aileron Control Horn and Torque Tube Repair | 413 |
| | Adjustment/Test | 501 |

**AA-5 SERIES
MAINTENANCE MANUAL**

| <u>NUMBER</u> | <u>PAGE</u> |
|---|-------------|
| Aileron Rigging | 501 |
| Control Surfaces Balancing Procedures | 501 |
| Cleaning/Painting | 701 |
| 27-2-1 RUDDER & TAB | |
| Description/Operation | 1 |
| General | 1 |
| Maintenance Practices | 301 |
| Servicing | 301 |
| Lubrication | 301 |
| Removal/Installation | 401 |
| Rudder Removal/Installation | 401 |
| Rudder Pedal Removal/Installation | 403 |
| Rudder Cable Removal/Installation | 405 |
| Rudder Bearing Removal/Installation | 405 |
| Rudder Bearing Wear Limits | 405 |
| Rudder Bellcrank and Torque Tube Repair | 407 |
| Adjustment/Test | 501 |
| Rudder Rigging | 501 |
| Rudder Balancing | 505 |
| Cleaning/Painting | 701 |
| 27-3-1 ELEVATOR & TAB | |
| Description/Operation | 1 |
| General | 1 |
| Maintenance Practices | 301 |
| Servicing | 301 |
| Lubrication | 301 |

**AA-5 SERIES
MAINTENANCE MANUAL**

| <u>NUMBER</u> | <u>PAGE</u> |
|---|-------------|
| Removal/Installation | 401 |
| Elevator Removal/Installation (AA-5 Aircraft) | 401 |
| Elevator Removal/Installation (AA-5A and AA-5B Aircraft) | 401 |
| Elevator Disassembly/Assembley (AA-5 Aircraft) | 401 |
| Elevator Disassembly/Assembly (AA-5A and AA-5B Aircraft) | 407 |
| Trim Tab Control Removal/Installation | 409 |
| Elevator Bearing Removal/Installation | 412 |
| Elevator Bearing Wear Limits | 412 |
| Elevator Trim Tab Free Play Reduction | 413 |
| Elevator Bellcrank and Torque Tube Repair | 414 |
| Adjustment/Test | 501 |
| Elevator Rigging | 501 |
| Elevator Balancing | 508 |
| Elevator Trim Tab Free Play Measurement | 509 |
| Cleaning/Painting | 701 |
| General | 701 |
| 27-5-1 FLAPS | |
| Description/Operation | 1 |
| General | 1 |
| Flap Structure | 1 |
| Flap Drive and Linkage | 1 |
| Flap Electrical System | 1 |
| Troubleshooting | 101 |
| Troubleshooting Flaps (AA-5 Aircraft Prior to S/N 0022) | 101 |
| Troubleshooting Flaps (AA-5 Aircraft S/N 0022 and Subsequent, AA-5A and AA-5B) | 102 |

**AA-5 SERIES
MAINTENANCE MANUAL**

| <u>NUMBER</u> | <u>PAGE</u> |
|---|-------------|
| Servicing | 301 |
| Lubrication | 301 |
| Removal/Installation | 401 |
| Flap Assembly Removal/Installation | 401 |
| Flap Drive Removal/Installation | 401 |
| Flap Switch Removal/Installation | 403 |
| Microswitch Removal/Installation | 403 |
| Wiring Removal/Installation | 405 |
| Adjustment/Test | 501 |
| Rigging | 501 |
| Cleaning/Painting | 701 |
| Cleaning/Painting | 701 |
| 27-7-1 GUST LOCK | |
| Description/Operation | 1 |
| General | 1 |
| 27-8-1 STALL WARNING SYSTEM | |
| Description/Operation | 1 |
| General | 1 |
| Troubleshooting | 101 |
| Troubleshooting Stall Warning System (Aircraft AA5-0001 through 0834, AA5A-0001 through 0054 and AA5B-0001 through 0181) | 101 |
| Troubleshooting Stall Warning System (Aircraft AA5A-0055 and Subsequent, and AA5B-0182 and Subsequent) | 101 |
| Maintenance Practices | 401 |
| Removal/Installation | 401 |
| Stall Sensor Switch Removal/Installation | 401 |
| Stall Warning Horn Removal/Installation | 401 |
| Time Delay Controller Removal/Installation (Aircraft AA5-0001 Through 0834, AA5A-0001 through 0054, and AA5B-0001 through 0181) | 401 |
| Adjustment/Test | 501 |
| Stall Sensor Switch Adjustment/Operational Check | 501 |

FLIGHT CONTROLS - DESCRIPTION/OPERATION

1. General

The AA-5, AA-5A and AA-5B aircraft are all equipped with identical flight control systems. These systems consist of a dual control column of the "T" configuration, which operates conventional ailerons and an anti-servo elevator, dual rudder pedals which operate the rudder, and electrically actuated flaps.

2. Lateral Control System

The lateral control system consists of torque-tube actuated ailerons, positioned by cables extending from the control column. As either control wheel is turned the chain and sprocket drive to which it is coupled actuates a bellcrank to which the aileron control cables are attached.

3. Directional Control System

The directional control system consists of a conventional rudder actuated by control cables extending from the rudder pedal linkage.

4. Longitudinal Control System

The longitudinal control system consists of an anti-servo elevator actuated by control cables extending from the control column.

Longitudinal trim is provided by a trim tab mounted on the trailing edge of the elevator. This tab is actuated by a linkage that is adjusted by the trim wheel mounted on the console.

5. Flap System

The flap system consists of two wing flaps, one on each wing, mounted inboard of the ailerons, and an electrically operated flap drive mechanism. The flaps are actuated by torque tubes extending into the fuselage. Linkages transmit the linear motion of the actuator to the torque tubes.

6. Gust Lock

The gust lock consists of a metal pin that can be inserted through a hole in the control column to secure the ailerons and elevators against wind damage.

AA-5 SERIES
MAINTENANCE MANUAL

AILERON & TAB - DESCRIPTION/OPERATION

1. General (See Figure 1.)

As the control wheel is rotated its angular displacement is transmitted through a sprocket and chain arrangement on the control column to the bellcrank. Control cables attached to the bellcrank are routed through idler pulleys to the control horns attached to the aileron torque tubes. The control horns rotate the torque tubes, thus positioning the aileron control surfaces in direct proportion to control wheel displacement. A carry-through cable, attached to the control horns, extends aft to the carry-through pulley in the aft fuselage. This cable provides completion of the aileron control loop such that as one aileron moves up the other aileron moves down.

The aileron control surfaces are mounted on bearings that fit over the torque tube at each end of the control surface. Each aileron is composed of a formed metal skin which is bonded to seven internal ribs. The internal ribs are made of aluminum honeycomb. The torque tube extends the length of the aileron through the flap, and into the fuselage. The torque tube forms the aileron hinges. The aileron counterweight and control stop are mounted on the outboard end of the torque tube. The forward channels are riveted to the torque tube and form the contour of the aileron leading edge. The skin is bonded to the channels along its forward seam. In addition, the torque tube is bonded to the ribs. This type of structure enables rotational movement of the torque tube to position the control surface. Ground adjustable trim tabs are attached to the trailing edge of the control surfaces at their outboard ends.

The control column (Figure 2) consists of a "T" column, the bottom of which is attached to the aircraft through a needle bearing hinge. A bicycle-type chain extends around sprockets attached to the control wheel shafts, around an idler sprocket, and around a sprocket attached to the bellcrank. The three turnbuckles on the chain enable adjustment of chain tension, adjustment of the relative control wheel positions, and adjustment of the bellcrank in relation to control wheel position. The shaft of each control wheel is attached through a universal joint to the "T" column. This allows forward and aft movement of the control column (for elevator action) while ensuring that the angular movement of the control wheel is transmitted to the sprocket. Needle bearings in the "T" column and in the sprockets minimize control system friction.

AA-5 SERIES
MAINTENANCE MANUAL

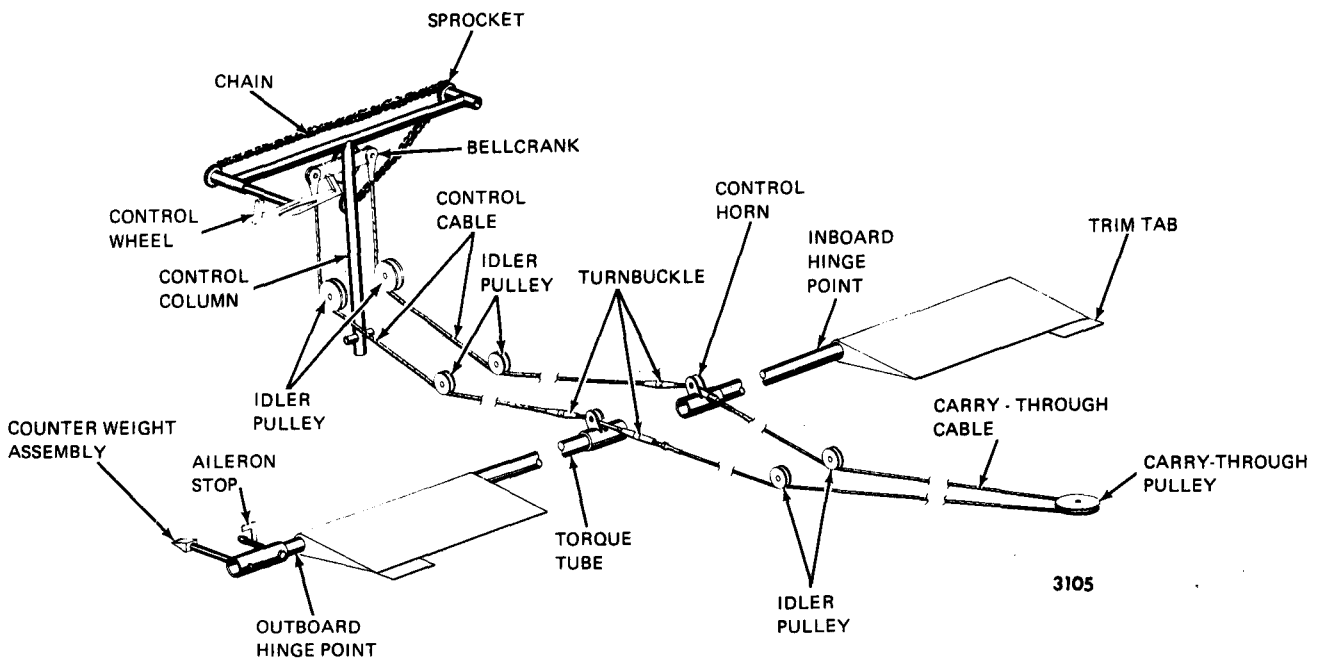
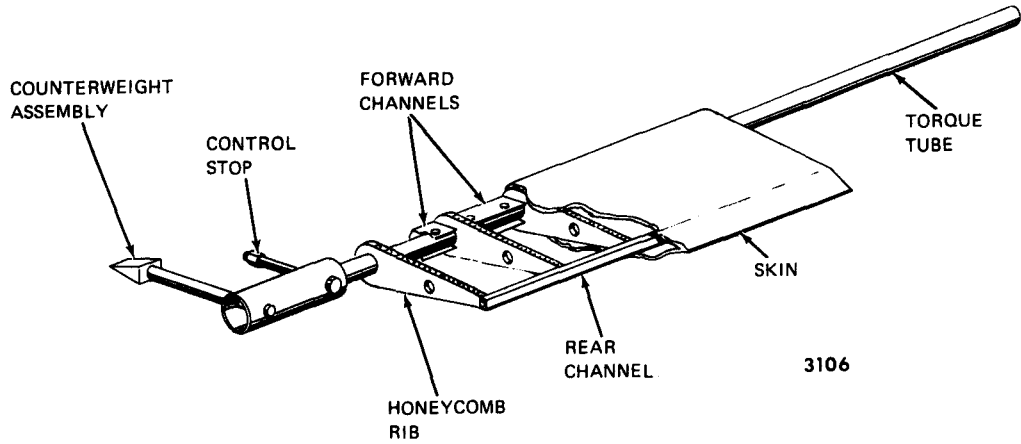

Aileron Control System
Figure 1

AA-5 SERIES
MAINTENANCE MANUAL

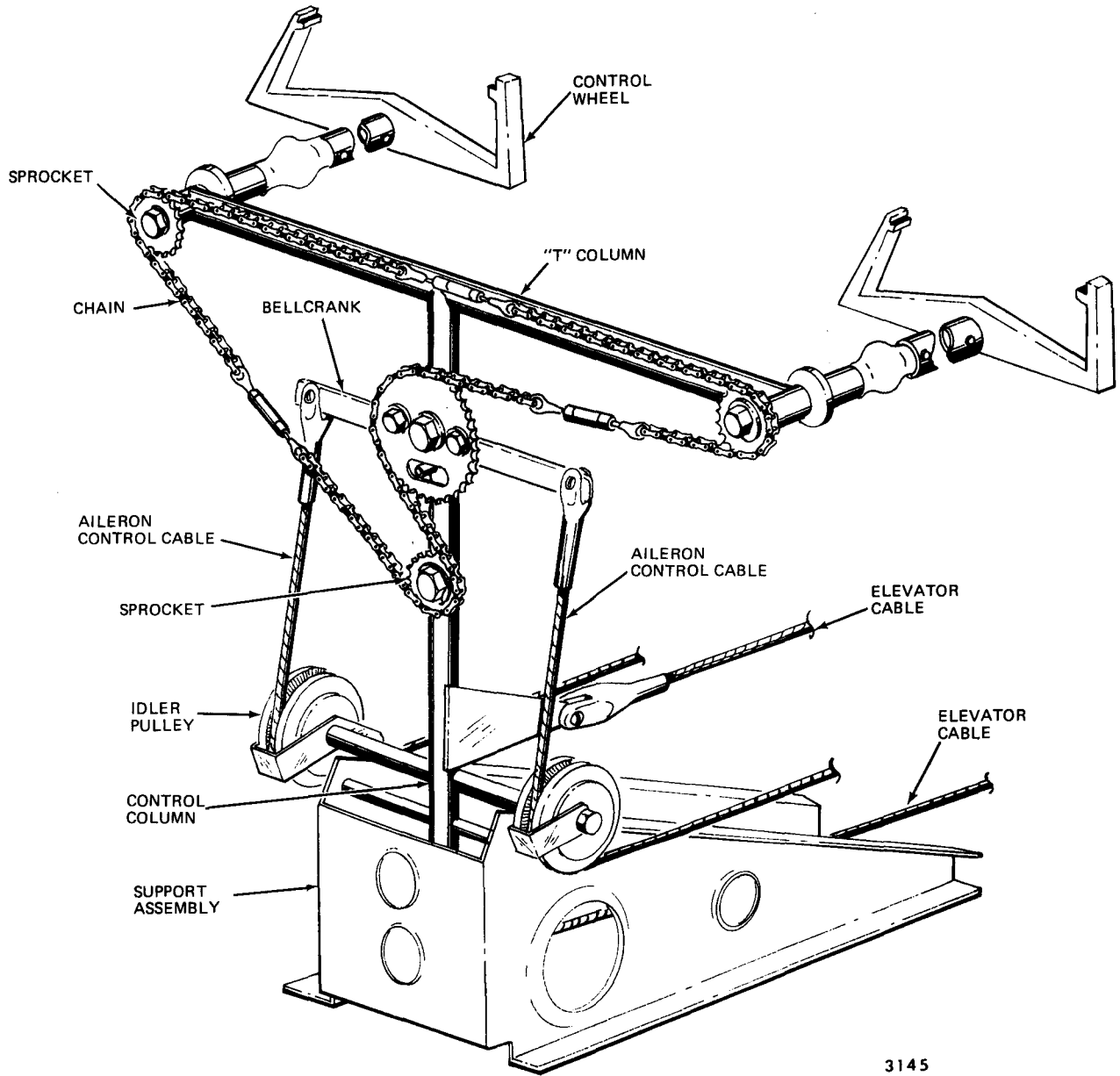

3145

Control Column
Figure 2

MAINTENANCE PRACTICES — SERVICING

1. Lubrication of Aileron Bearings and Control Column

A. Aileron Bearing Lubrication

Lubricate the aileron bearings by injecting a small amount of grease, MIL-G-7711 (see Chapter 12) between the bearings and torque tube.

B. Control Column Lubrication

Proper lubrication of the needle bearings in the control column requires disassembly of the control column. Disassemble the control column as described in Removal/Installation, Paragraph 7, this chapter, and lubricate the bearings as follows:

WARNING: USE SOLVENTS IN A WELL VENTILATED AREA. AVOID BREATHING FUMES. KEEP AWAY FROM FLAMES.

- (1) Use Stoddard solvent, or equivalent, to wash all grease from the needle bearings and thrust bearings.
- (2) Inspect bearings for excessive wear or damage. Replace if defective.
- (3) Use a clean, lint-free cloth saturated with Stoddard solvent, or equivalent, to remove all grease and foreign material from bearing races.
- (4) Inspect races for excessive wear or damage. Replace if defective.
- (5) Pack needle bearings and thrust bearings with MIL-G-7711 grease. (See Chapter 12.)
- (6) Assemble control column as described in Removal/Installation, Paragraph 7B, this chapter.
- (7) Use a clean, lint-free cloth saturated with Stoddard solvent or equivalent, to wipe all foreign material from the chain and sprockets.
- (8) Lubricate the chain with a light coat of MIL-G-7711 grease. (See Chapter 12.)

MAINTENANCE PRACTICES – REMOVAL/INSTALLATION

1. Aileron and Torque Tube Removal/Installation

NOTE: The following procedure treats the aileron and torque tube as a unit. Refer to Paragraph 6 for Removal/Installation of aileron only.

A. Aileron and Torque Tube Removal (See Figure 401.)

- (1) Remove trim per Chapter 25 to gain access to the aileron control horns.
- (2) Remove nut (1) and washer (2) from bolt (3) that secures control horn (4) to torque tube (11).
- (3) Remove wing tip as described in Chapter 57.
- (4) Remove nuts (5), washers (6), and bolts (7) from wing and remove control stop (8) and bearing bracket (9) from wing. Disconnect ground terminal.
- (5) Pull aileron outboard until torque tube clears inboard hinge.

B. Aileron and Torque Tube Installation (See Figure 401.)

NOTE: When installing the aileron, the torque tube may catch on the ribs in the flap as the tube is pushed through. A guide such as the one shown in Figure 402 may be helpful in preventing this.

- (1) Slide aileron torque tube through the flap until it extends into the fuselage. Connect ground terminal.
- (2) Position torque tube in control horn (4) until the holes align.
- (3) Position bearing bracket (9) and control stop (8) so that their mounting holes align with those in the wing.
- (4) Secure with bolts (7), washers (6), and nuts (5). Torque to 50 inch pounds.
- (5) Secure with bolt (3), washers (2), and nut (1).
- (6) Install wing tip as described in Chapter 57.
- (7) Install trim as described in Chapter 25.

2. Aileron Bearing Removal/Installation (See Figure 403.)

A. Aileron Bearing Removal

- (1) Remove aileron as described in Removal/Installation, Paragraph 1.
- (2) Collapse bearing as shown in Figure 403 and remove from bearing support.

NOTE: Do not attempt to collapse a new bearing if it is cold (below 70°F) since the bearing material loses its elasticity and may break if it is collapsed while cold. Bearing installation can be facilitated by warming the bearing to body temperature (98°F).

B. Aileron Bearing Installation

- (1) Collapse new bearing and install it in bearing support as shown in Figure 403.
- (2) Use aileron and flap bearing sizing tool, 1-1/8 inches I.D., Part No. DE-5006-1, to seat bearing so that it will fit over the torque tube.

NOTE: Once inserted in the support bracket the bearing I.D. should be rounded out or "sized" by inserting the correct bearing sizing tool and rolling the new insert into it correct size. New bearings should be sized to prevent control system stiffness.

- (3) Lightly grease the bearing with MIL-G-7711 grease. (See Chapter 12.)
- (4) Install aileron as described in Removal/Installation, Paragraph 1.

AA-5 SERIES
MAINTENANCE MANUAL

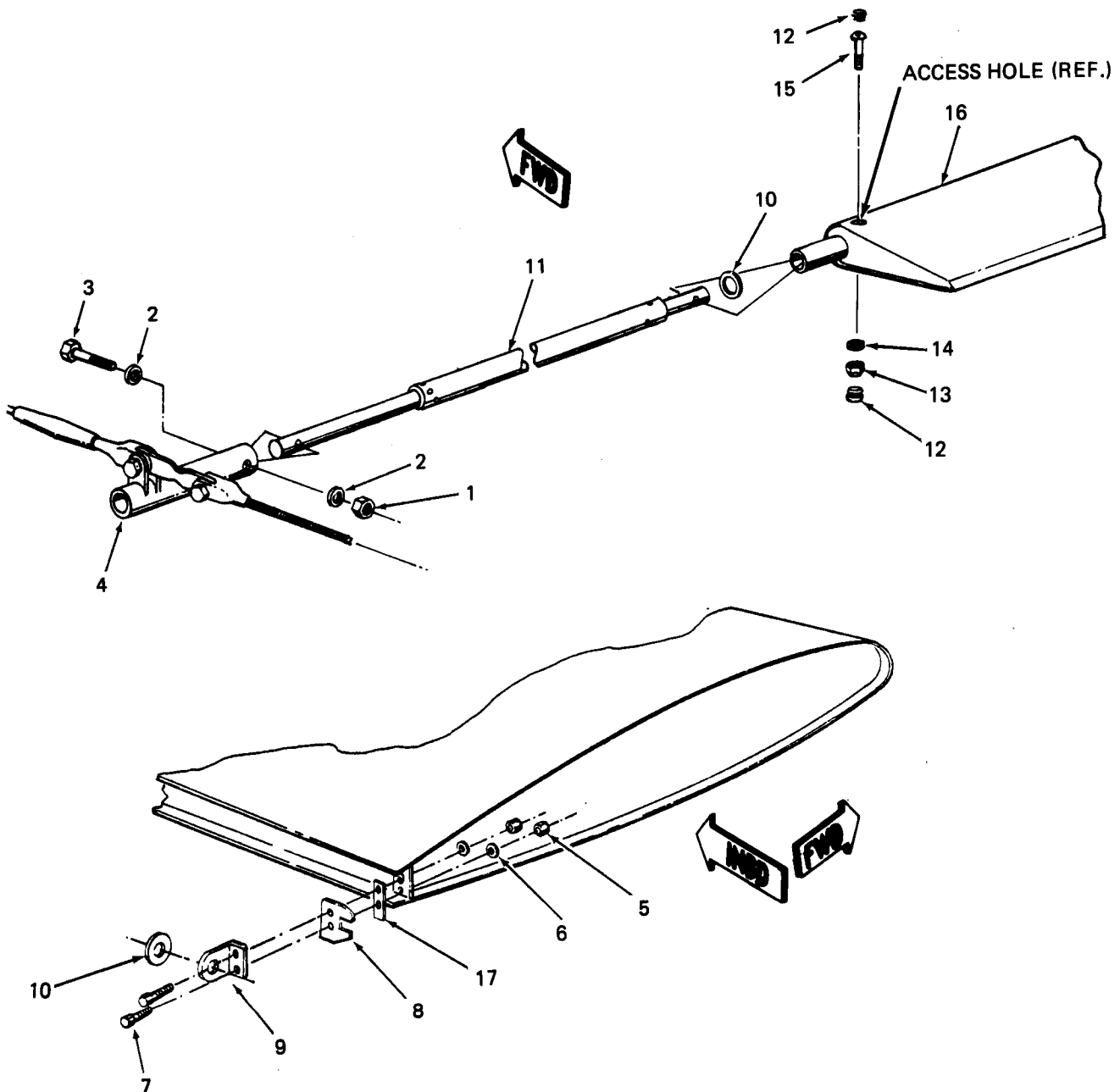

- | | |
|--------------------|-------------------------|
| 1. NUT | 10. SPACERS |
| 2. WASHER | 11. AILERON TORQUE TUBE |
| 3. BOLT | 12. PLUG |
| 4. CONTROL HORN | 13. NUT |
| 5. NUT | 14. WASHER |
| 6. WASHER | 15. BOLT |
| 7. BOLT | 16. AILERON |
| 8. CONTROL STOP | 17. SHIMS |
| 9. BEARING BRACKET | |

Aileron and Torque Tube Removal/Installation
Figure 401

AA-5 SERIES
MAINTENANCE MANUAL

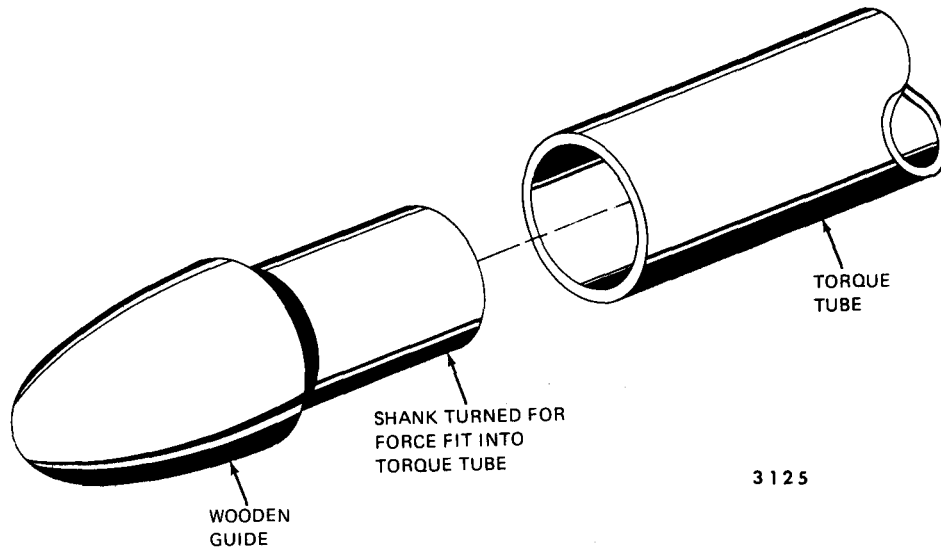

Torque Tube Guide
Figure 402

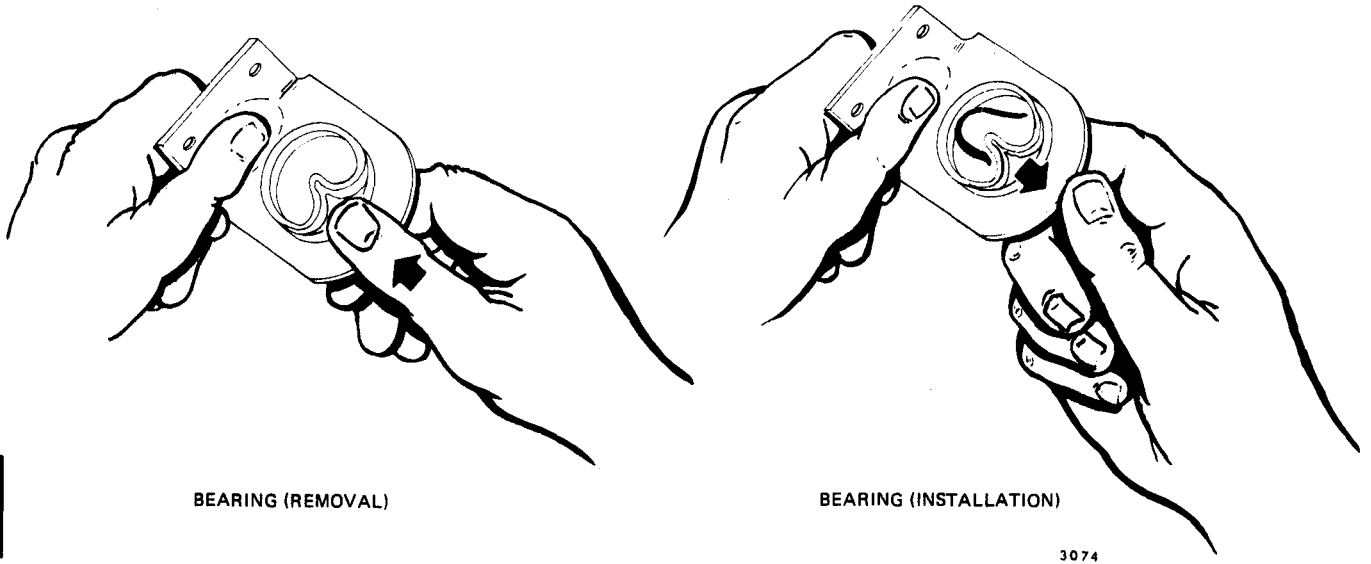

Aileron Bearing Removal/Installation
Figure 403

3. Aileron Bearing Wear Limits

The maximum wear limits for the 902013 bearings are as follows:

| | | |
|------------------------|---------------------------|-------------------|
| Minimum wall thickness | $\frac{-1, -2, -3}{.030}$ | $\frac{-4}{.040}$ |
|------------------------|---------------------------|-------------------|

Any bearings that have been worn to the above limits must be replaced.

In addition, any bearing with a cracked or separated flange must be replaced.

NOTE: Maximum control surface, or control surface torque tube wear is .030 wall thickness reduction. Wear greater than this requires replacement of the control surface. Service kit No. SK-121, control surface torque tube repair kit, is available from the Grumman American Supply Operations Department for worn torque tubes that have not exceeded the maximum wear limits.

4. Aileron Cable Removal/Installation (See Figure 404.)

A. Control Cable Removal

- (1) Remove trim per Chapter 25 to gain access to the aileron control horns.
- (2) Remove console trim per Chapter 25 to gain access to the idler pulleys forward of the spar center section.
- (3) Remove cotter pin (1), nut (2), washer (3) and bolt (4) from cable clevis end (5), and remove cable clevis (5) from bellcrank (6).
- (4) Remove nut (7), washer (8), and bolt (9).
- (5) Remove guards (10) from pulleys (11) to clear cables (12).
- (6) Remove nuts (13) and washers (14) and lift control pulley assembly (15) to clear cables (12).
- (7) Pull cables (12) from beneath control pulley assembly (15) and spar center section.
- (8) Remove cotter pin (16), nut (17), washer (18), and bolt (19).
- (9) Remove cable clevis (20) from control horn (21).

B. Control Cable Installation (See Figure 404.)

- (1) Position cable clevis (20) and link (22) in control horn (21) and secure with bolt (19), washer (18), nut (17) and cotter pin (16).
- (2) Route cables (12) under spar center section and under outboard pulley of control pulley assembly (15).
- (3) Secure control pulley assembly (15) with washers (14) and nuts (13).
- (4) Route cable (12) around pulley (11) and position guards (10) over cable (12).
- (5) Install bolt (9) through guards (10) and pulleys (11), and secure with washer (8) and nut (7).
- (6) Position cable clevis end (5) over bellcrank (6) and secure with bolt(4), washer (3), nut (2) and cotter pin (1).
- (7) Rig aileron controls as described in Adjustment/Test, Paragraph 1.
- (8) Reinstall trim removed as described in Chapter 25.

AA-5 SERIES
MAINTENANCE MANUAL

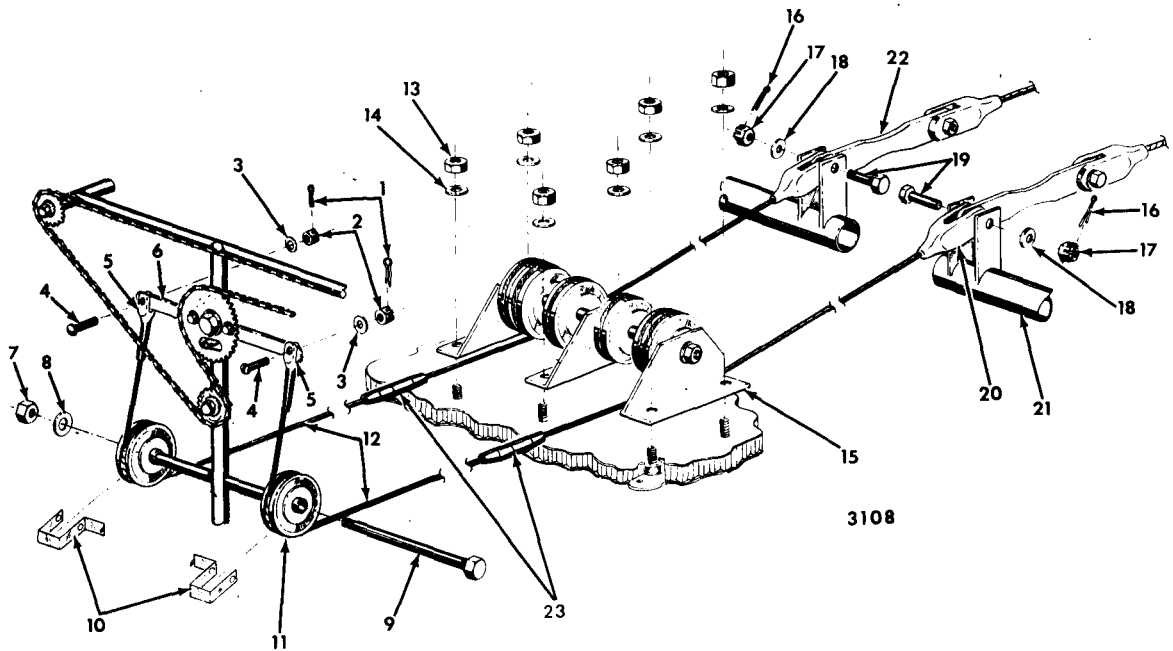

- | | |
|---------------|--------------------|
| 1. Cotter Pin | 13. Nut |
| 2. Nut | 14. Washer |
| 3. Washer | 15. Pulley Bracket |
| 4. Bolt | 16. Cotter Pin |
| 5. Clevis | 17. Nut |
| 6. Belcrank | 18. Washer |
| 7. Nut | 19. Bolt |
| 8. Washer | 20. Clevis |
| 9. Bolt | 21. Control Horn |
| 10. Guard | 22. Link |
| 11. Pulleys | 23. Turnbuckle |
| 12. Cable | |

Aileron Cable Removal/Installation
Figure 404

**AA-5 SERIES
MAINTENANCE MANUAL**

C. Carry-Through Cable Removal (See Figure 405.)

- (1) Remove console trim as described in Chapter 25 to provide access to the aileron control horns.
- (2) Remove emergency locator transmitter access panel per Chapter 53.
- (3) Remove nut (1), washer (2), and bolt (3) and remove link (4) from control horn (5).
- (4) Remove cotter pin (6) from guard (7) and remove guard from bracket (8).
- (5) Remove nut (9), washer (10), and bolt (11) from bracket (12).
- (6) Remove guard (13) and carry-through pulley (14) from bracket (12).
- (7) Slide carry-through cable (15) from pulley (14) and remove from aircraft.

D. Carry-Through Cable Installation (See Figure 405.)

- (1) Place carry-through cable (15) on pulley (14) and insert pulley (14) in bracket (12).
- (2) Install guard (13), bolt (11), washer (10), and nut (9). Torque to standard value per Chapter 91.
- (3) Route cable (15) under outboard pulleys (16) and install guard (7). Secure with cotter pin (6).
- (4) Insert link (4) into clevis (17) and place link and clevis in control horn (5). Secure with bolt (3), washer (2) and nut (1). Torque to standard value per Chapter 91.
- (5) Install emergency locator transmitter access panel per Chapter 53.
- (6) Rig aileron controls per Adjustment/Test, Paragraph 1, this chapter.
- (7) Install console trim per Chapter 25.

5. Control Column Removal/Installation

A. Control Column Removal (See Figure 406.)

- (1) Remove console trim per Chapter 25.
- (2) Remove cotter pin (1), nut (2), washer (3) and bolt (4) attaching elevator and aileron control cables (5) to the control column (6).
- (3) Remove nut (7), washer (8) and bolt (9). Slide control wheel shaft (10) from universal (11) and remove shaft from aircraft.
- (4) Remove six (3 on each side) nuts (12) and washers (13) securing support assembly (14) to aircraft floor.
- (5) Remove nut (15), washer (16) and bolt (17) from control column (6).
- (6) Remove guards (18) from pulleys (19) and remove cables (5) from column.
- (7) If an autopilot is installed, remove it per Chapter 22.
- (8) Remove control column from aircraft.
- (9) Remove washer (20) and rivet (21) from control wheel (22) and remove wheel from shaft (10).

**AA-5 SERIES
MAINTENANCE MANUAL**

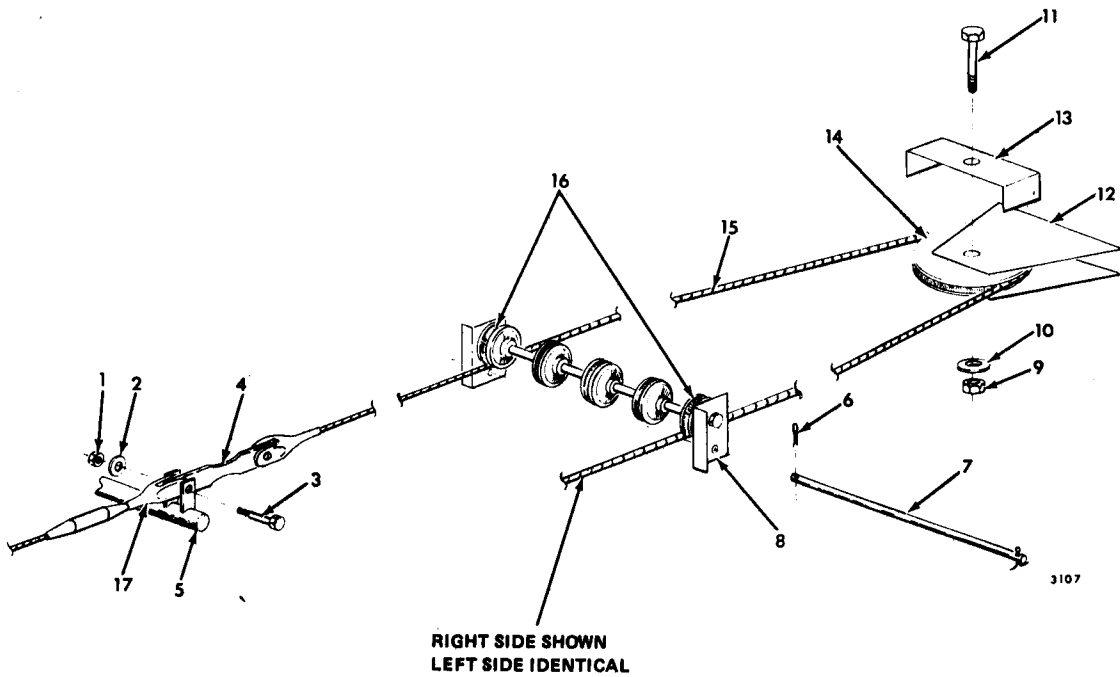

- | | |
|-----------------|-------------|
| 1. Nut | 9. Nut |
| 2. Washer | 10. Washer |
| 3. Bolt | 11. Bolt |
| 4. Link | 12. Bracket |
| 5. Control Horn | 13. Guard |
| 6. Cotter Pin | 14. Pulley |
| 7. Guard | 15. Cable |
| 8. Bracket | 16. Pulley |

Carry Through Cable Removal/Installation
Figure 405

B. Control Column Installation (See Figure 406.)

- (1) Position control column such that support assembly (14) fits over its six mounting studs. Secure support with six washers (13) and nuts (12). Torque to standard value. (See Chapter 91.)
- (2) Attach elevator cables (5) to control column (6) with bolt (4), washer (3), nut (2) and cotter pin (1).
- (3) Place aileron cables (5) over pulleys (19) and place guards (18) over pulleys.
- (4) Align guards (18) and pulleys (19) with control column and secure with bolt (17), washer (16) and nut (15). Torque to standard value. (See Chapter 91.)
- (5) Attach aileron cables (5) to bellcrank (23) with bolt (4), washer (3), nut (2) and cotter pin (1).
- (6) Attach control wheel (22) to shaft (10) with rivet (21) and washer (20).
- (7) Slide shaft (10) through guide in instrument panel, and over end of universal (11).
- (8) Align holes and attach shaft (10) to universal (11) with bolt (9), washer (8) and nut (7). Torque to standard value. (See Chapter 91.)
- (9) If autopilot is used, install per Chapter 22.
- (10) Rig controls per Adjustment/Test, Paragraph 1, this chapter.
- (11) Install console trim per Chapter 25.

6. Control Column Disassembly/Assembly

A. Control Column Disassembly (See Figure 407.)

- (1) Loosen turnbuckle (1) and remove chain (2) from sprockets (3), (4), and (5).
- (2) Remove nut (6), washer (7), and bolt (8) from collar (9), and remove spacer (10), and universal (11).
- (3) Grasp sprocket (3) and pull shaft (12) from control column (13). Shims (14) and thrust plate (15) will fall from shaft.
- (4) Remove thrust plate (15) and spacer (16) from shaft (12).
- (5) Drive pin (17) from shaft (12) and remove sprocket (3).
- (6) Pull thrust bearings (18) from control column.
- (7) Remove nut (19), washer (20), and bolt (21) from control column (13).
- (8) Remove washer (22), sprocket (4), needle bearing (23), sleeve (24), and washers (25) from bolt (21).
- (9) Remove nut (26), washer (27) and bolt (28) from control column (13).
- (10) Remove washer (29), sprocket (5), needle bearing (30), sleeve (31), and washers (32) from bolt (28).
- (11) Remove nut (33), washer (34) and bolt (35) from sprocket (5) and remove bellcrank (36).
- (12) Remove bushing (37) from control column.

**AA-5 SERIES
MAINTENANCE MANUAL**

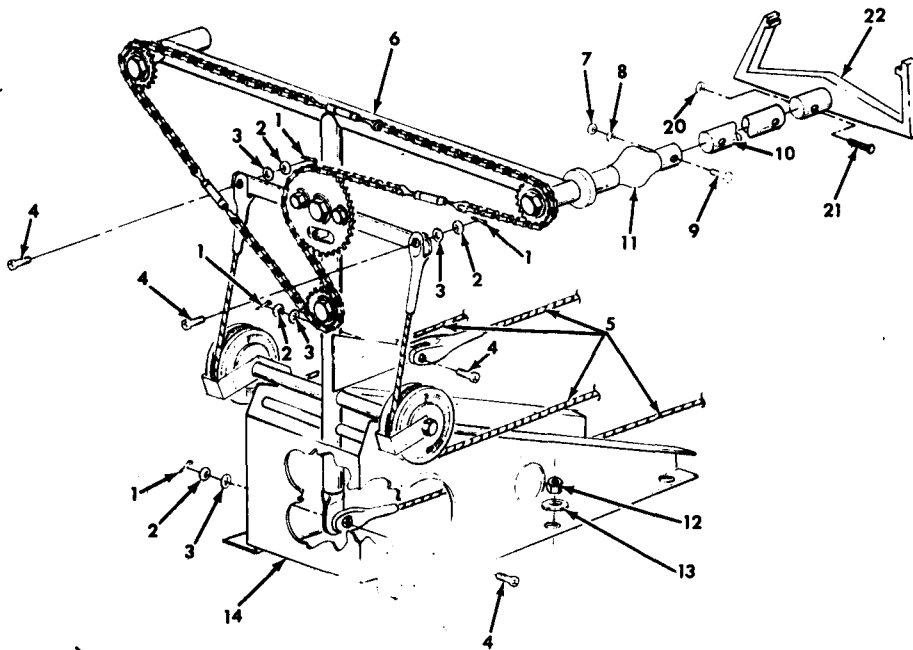

- 1. Cotter Pin
- 2. Nut
- 3. Washer
- 4. Bolt
- 5. Cables
- 6. Control Column
- 7. Nut
- 8. Washer
- 9. Bolt
- 10. Control Wheel Shaft
- 11. Universal
- 12. Nut

- 13. Washer
- 14. Support
- 15. Nut
- 16. Washer
- 17. Bolt
- 18. Guard
- 19. Pulley
- 20. Washer
- 21. Rivet
- 22. Control Wheel
- 23. Bellcrank

3109

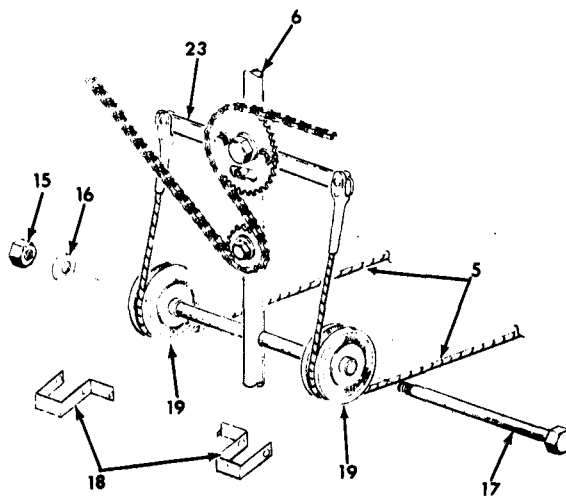

**Control Column Removal/Installation
Figure 406**

**AA-5 SERIES
MAINTENANCE MANUAL**

- (13) On aircraft AA5-0432 and on, AA-5A and AA5B-0001 and on, remove nut (38), and bolt (39), and lift control column (13) from support assembly (40).
- (14) On AA5-0001 through AA5-0431 aircraft, remove nut (41), washers (42), and pin (43) from support assembly (40). Remove sleeve (44) from control column (13).
- (15) Remove needle bearing (45) from control column (13).
- (16) Disassemble chain (2) by unscrewing turnbuckles (1), (46), and (47).

B. Control Column Assembly (See Figure 407.)

- (1) Install needle bearings (45) in control column (13).
- (2) On aircraft AA5-0432 and on, AA05A and AA5B-0001 and on, position control column (13) in support assembly (40) such that the mounting holes align. Install bolt (39) and nut (38). Torque to allow free movement.
- (3) On all other aircraft, install sleeve (44) in control column (13), and position control column in support assembly (40) such that the mounting holes align. Install pin (43) and secure with washers (42) and nuts (41). Torque per Chapter 91.
- (4) Install bushing (37) in control column (13).
- (5) Position bellcrank (36) on sprocket (5) such that attachment holes align. Secure with bolts (35), washers (34) and nuts (33). Torque to standard value. (See Chapter 91.)
- (6) Place washers (32), and sleeve (31) on bolt (28).
- (7) Place needle bearing (30) over sleeve (31).
- (8) Install bolt (28), and needle bearing (30) in sprocket (5), and place washer (29) on bolt (28) behind bellcrank (36).
- (9) Install bolt (28) in control column (13) and secure with washer (27) and nut (26). Torque per Chapter 91.
- (10) Place washers (25) on bolt (21).
- (11) Place sleeve (24), on bolt (21) and place needle bearing (23) over sleeve (24).
- (12) Place sprocket (4) over needle bearing (23) and place washer (22) on bolt behind sprocket (4).
- (13) Install bolt (21) in control column (13) and secure with washer (20) and nut (19). Torque per Chapter 91.
- (14) Place sprockets (3) on end of shafts (12) and secure with drive pins (17).
- (15) Place spacers (16) and thrust plates (15) on shafts (12).
- (16) Install thrust bearings (18) in control column.
- (17) Slide shafts (12) through thrust bearings (18) and install thrust plates (15), shims (14) and collars (9) on shafts (12). Align holes in collars (9) and shafts (12).
- (18) Place spacers (10) in end of universals (11) such that holes align, then insert universals (11) in end of shafts (12).

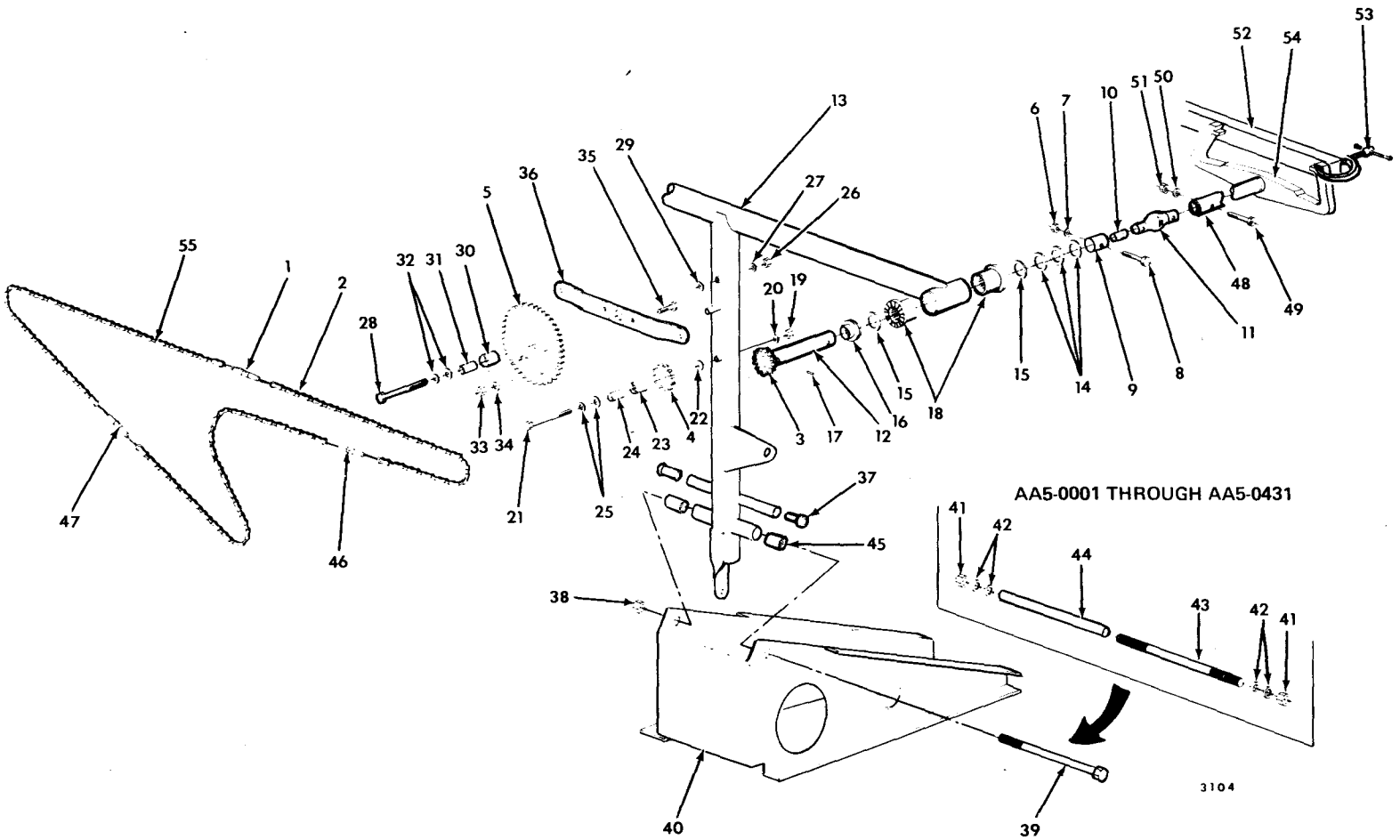

Control Column Disassembly/Assembly (Sheet 1 of 2)
Figure 407

AA-5 SERIES
MAINTENANCE MANUAL

| | |
|--------------------|-------------------------|
| 1. Turnbuckle | 28. Bolt |
| 2. Chain | 29. Washer |
| 3. Sprocket | 30. Needle Bearing |
| 4. Sprocket | 31. Sleeve |
| 5. Sprocket | 32. Washers |
| 6. Nut | 33. Nut |
| 7. Washer | 34. Washer |
| 8. Bolt | 35. Bolt |
| 9. Collar | 36. Bellcrank |
| 10. Spacer | 37. Bushing |
| 11. Universal | 38. Nut |
| 12. Shaft | 39. Bolt |
| 13. Control Column | 40. Support |
| 14. Shims | 41. Nut |
| 15. Thrust Plate | 42. Washers |
| 16. Spacer | 43. Pin |
| 17. Pin | 44. Sleeve |
| 18. Thrust Bearing | 45. Needle Bearing |
| 19. Nut | 46. Turnbuckle |
| 20. Washer | 47. Turnbuckle |
| 21. Bolt | 48. Shaft |
| 22. Washer | 49. Bolt |
| 23. Needle Bearing | 50. Washer |
| 24. Sleeve | 51. Nut |
| 25. Washers | 52. Wood Block |
| 26. Nut | 53. Clamp |
| 27. Washer | 54. Control Wheel |
| | 55. Chain Tension Point |

Control Column Disassembly/Assembly (Sheet 2 of 2)
Figure 407

- (19) Align holes in universals (11) and shafts (12) and secure with bolts (8), washers (7) and nuts (6). Torque to standard value. (See Chapter 91.)
- (20) Install and align chain (2) as follows:
- (a) Place control wheel shafts (48) on universals (11) and secure with bolts (49), washers (50), and nuts (51).
 - (b) Use a straight piece of wood (52) and two clamps (53) to hold both control wheels (54) at their neutral positions.
 - (c) Position bellcrank (36) so that it is horizontal.
 - (d) Route chain (2) around the two upper sprockets (3) such that the turnbuckle (1) is over the large sprocket (5), and such that turnbuckle (46) is approximately half-way between sprockets (3) and (5).
 - (e) Route chain (2) over sprocket (5), under and around sprocket (4) and to sprocket (3).
 - (f) Adjust turnbuckle (1) to take up slack in chain between two upper sprockets (3).
 - (g) Adjust turnbuckles (46) and (47) to take up remaining slack in chain.
 - (h) Tighten all three turnbuckles until chain tension is such that a 2-pound force applied to the chain at point (55) will cause a 1/4 inch deflection in chain, and the bellcrank (36) is horizontal when both wheels (54) are at their neutral position.
 - (i) Safety wire turnbuckles, with .032 wire.

**AA-5 SERIES
MAINTENANCE MANUAL**

7. Aileron Removal/Installation

NOTE: Refer to Paragraph 1 above for removal of the aileron and torque tube as a unit.

A. Aileron Removal (See Figure 401.)

- (1) Remove the wing tip. Refer to Chapter 57.
- (2) Locate and disconnect the ground strap at the aileron leading edge.
- (3) Remove plugs (12, Figure 401) from aileron (16).
- (4) Remove nut (13) washers (14) and bolt (15). Slide aileron (16) off end of torque tube (11).

B. Aileron Installation (See Figure 401.)

- (1) Slide aileron (16) onto end of torque tube (11). Align bolt holes in torque tube and aileron. Install bolt (15), washers (14), and nut (13). Tighten nut (13) to standard torque value (Chapter 91).
- (2) Install ground strap to aileron leading edge.
- (3) Install the control wheel lock in the control wheel shaft. Place the aileron rigging fixture (Part No. DE-5003-501) on the wing at Wing Station 140. The aileron should be positioned at 0° on the rigging fixture.
- (4) Remove the control wheel lock and move the control wheel through its full travel, noting the position at which the aileron contacts the stops. The aileron should contact at 15° + 2°, -0° up, and 7½° + 2½°, -0° down.
- (5) If the requirements of Steps (3) and (4) are not met, rig the ailerons. Refer to Adjustment/Test, Paragraph 1, this section, for rigging procedures.
- (6) Install and plug (12).
- (7) Install the wing tip. Refer to Chapter 57.

8. Aileron Control Horn and Torque Tube Repair

Excessive play between the ailerons and the control wheel can be caused by slippage at the aileron control horn and torque tube. In certain high-time, in-service aircraft, this condition has been traced to the enlargement or elongation of the attach holes in the aileron torque tube (11, Figure 401) at the aileron control horn (4).

The following is an acceptable repair from a structural standpoint:

- A. Install the control wheel lock in the control wheel shaft.
- B. Gain access to the aileron control horns (4, Figure 401) by removing required console covers and trim (Chapter 25). Hold one aileron control horn and attempt to rotate the attached aileron torque tube in both directions. Repeat this procedure on the opposite side.
- C. If play is noted, determine the largest diameter of the aileron torque tube and aileron control horn bolt holes.
- D. If the largest diameter exceeds 0.2505 inch, open the existing bolt holes in the aileron torque tube and aileron control horn to 0.312 to 0.315 inch diameter.

NOTE: Do not increase the hole size beyond that specified. If the holes will not clean up, the aileron control horn and aileron torque tube must be replaced. (On early model aircraft the torque tube is an integral part of the aileron and replacement of the whole assembly will be necessary.) If removal for repair/replacement is necessary, refer to Maintenance Practices — Removal/Installation Paragraphs 1, 4 and 7, this section.

- E. If existing bolt holes are opened in accordance with sub-paragraph D above, install oversize attach hardware listed below.

| | |
|-------------|---------|
| NAS464P5A19 | Bolt |
| AN960-516 | Washers |
| MS20364-524 | Nut |

- F. Perform aileron rigging check if repair or replacement is made. Refer to Adjustment/Test, Paragraph 1, this section, for rigging procedures.
- G. Record the repair/replacement in the aircraft log.

MAINTENANCE PRACTICES — ADJUSTMENT/TEST

1. Aileron Rigging

NOTE: The aircraft can be rigged to suit individual requirements by adjusting the fixed trim tabs on the ailerons. Do not exceed 45° as it will not contribute any more toward trim.

A. Aileron Rigging

- (1) Secure the control wheels in the neutral position by installing the control wheel lock in the control wheel shaft.
- (2) Place the aileron rigging fixture (Part No. DE-5003-501) on the right wing as shown in Figure 501.
- (3) Remove trim, per Chapter 25, to gain access to the aileron control horns.
- (4) Remove the locking clip from the turnbuckle immediately forward of the right control horn.
- (5) Adjust the turnbuckle until the right aileron is positioned at 0° on the rigging fixture
- (6) Place rigging fixture on the left wing.
- (7) Remove the locking clip from the turnbuckle immediately forward of the right control horn.
- (8) Adjust the turnbuckle until the left aileron is positioned at 0° on the rigging fixture.
- (9) Check control column cable tension. Tension shall be 30 ± 2 pounds.
- (10) Readjust turnbuckles until cable tension is 30 ± 2 pounds and both ailerons are positioned at 0° on the rigging fixture.
- (11) Ensure that control column chain tension is as described in Disassembly/Assembly, Paragraph 9, this chapter.
- (12) Install locking clips on turnbuckles and remove control wheel lock.
- (13) Use rigging fixture to check aileron travel as control wheel is moved through its full travel. Full travel for each aileron should be $15^\circ + 2, - 0^\circ$ up, and $7\frac{1}{2}^\circ + 2\frac{1}{2}^\circ, - 0^\circ$ down. The free aileron position should be $\pm 2^\circ$ of neutral.
- (14) If aileron travel does not fall within tolerance, remove wing tips per Chapter 57, and check aileron stops (Figure 401) for damage. Replace if damaged or bent.

NOTE: The down aileron contacts the stop before the up aileron. If aileron stops are not bent or damaged, file the stop contact surface until specified aileron travel is attained.

- (15) Reinstall wing tips (if removed) per Chapter 57.

2. Control Surfaces Balancing Procedures

A. Definitions (See Figure 502)

- (1) Underbalance is defined as the condition that exists when the control surface is trailing edge heavy and shall be symbolized by the plus (+) sign.
- (2) Neutral Static balance is defined as the condition that exists when the chord line of the control surface is horizontal when the surface is balanced.
- (3) Overbalance is defined as the condition that exists when the control surface is leading edge heavy and shall be symbolized by the minus (-) sign.

NOTE: This information is applicable to models AA-5, AA-5A and AA-5B for the purpose of clarifying and facilitating the balancing of movable control surfaces.

AA-5 SERIES
MAINTENANCE MANUAL

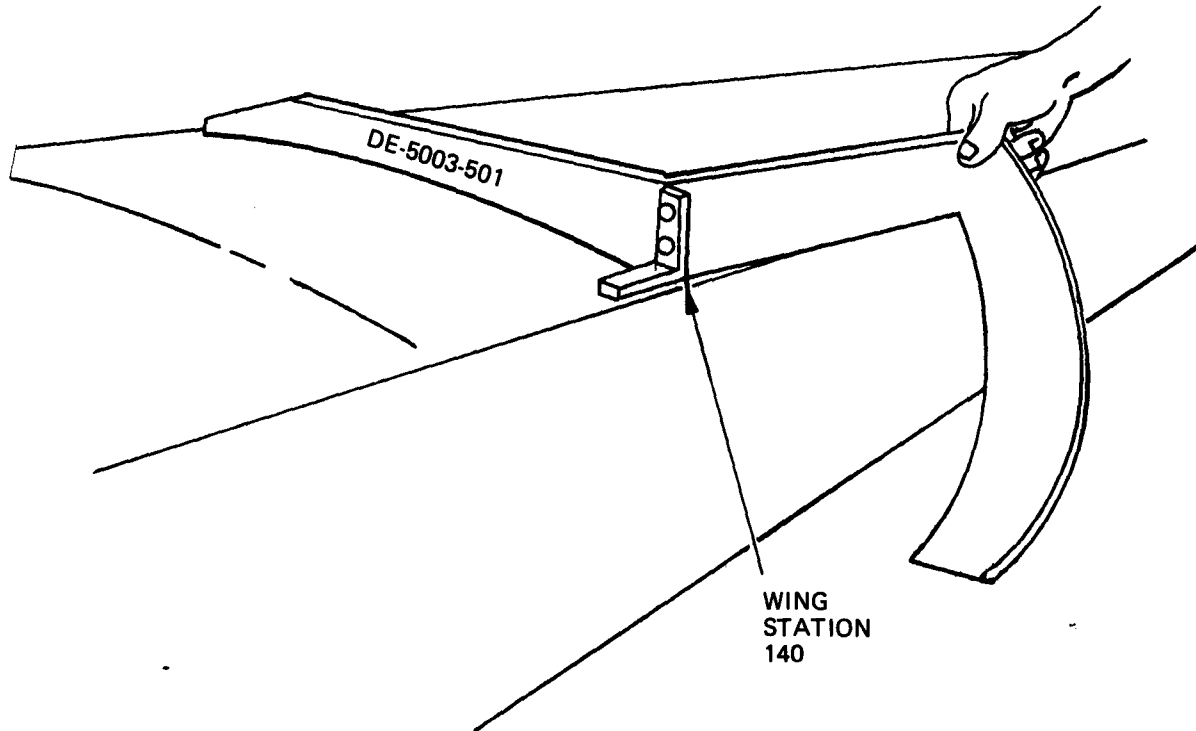

Aileron Rigging Fixture
Figure 501

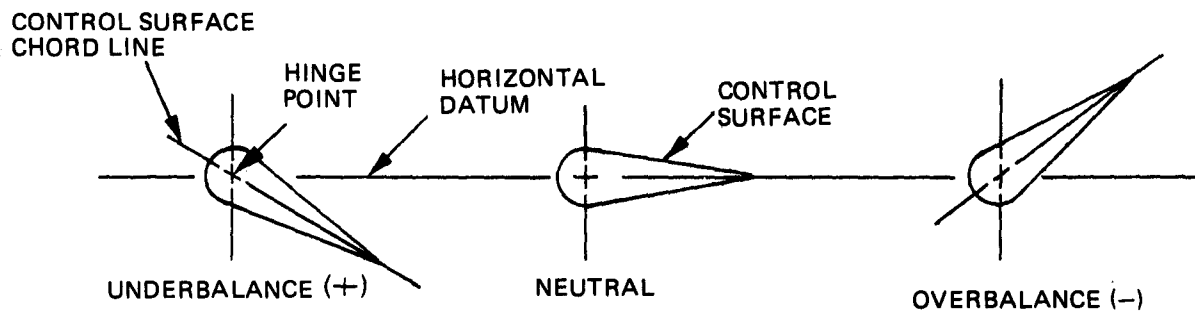

Control Surface Static Balance
Figure 502

3886

B. General Balancing Procedures

NOTE: The balancing device may be constructed in any manner as long as the requirements given below are met.

- (1) A line drawn through the hinge line support points must be level and perpendicular to the supporting knife edges.
- (2) The supporting knife edges must be horizontal and parallel to each other within the requirements of sub-paragraph (1) above. The knife edges must be designed to allow the control surface to pivot freely about the hinge points.
- (3) The control surface must always be balanced with the hinge line in a horizontal attitude.
- (4) The area in which balancing operations are performed must be free of drafts or other air movements which might disturb the balancing operation.
- (5) Control surfaces equipped with trim tabs must have the tab and the tab actuating rod in place during the balancing operation.
- (6) The balancing device must include a means for accurately measuring the distance of the gage weight from the hinge line. The size of the gage weight is not critical as long as its weight in ounces is accurately known; however, if the values given in table 1 are used, computation of moment will not be necessary.
- (7) The balancing device must include a means of determining when the chord line of the control surface is horizontally level, indicating a balanced condition exists.
- (8) Control surface balance must be rechecked after any painting, striping, repairs, or alterations to any control surface. An out-of-balanced control surface can seriously affect control and performance of the airplane.

NOTE: A typical device meeting these requirements is shown in Figure 503.

TABLE 1. CONTROL SURFACE BALANCE DATA (Painted surface)

| MODEL | CONTROL SURFACE | GAGE WT. (oz) | LIMIT (INCHES) | | MOMENT (IN. OZ) |
|---------------|-----------------|---------------|----------------|---------|-----------------|
| | | | AFT | FWD | |
| AA5/AA5A/AA5B | Aileron | 8 | 2 | 4 | -16 to +32 |
| AA5/AA5A/AA5B | Rudder | 8 | 4 | 2 | -32 to +16 |
| AA5 | Elevator | 8 | — | 6 to 12 | +48 to +96 |
| AA5A/AA5B | Elevator | 8 | 14 to 2 | — | -112 to -16 |

C. Aileron Balancing (See Figures 503 and 504)

- (1) Level the balancing device.
- (2) Support the Aileron on the knife edges of the balancing device at both ends of the hinge line.

NOTE: The torque tube is the hinge line of the aileron.

- (3) Provide aileron chord line/horizontal datum reference as follows:

- (a) Place a light mark through the center of the torque tube and the center of the aileron trailing edge.

CAUTION: DO NOT USE A SCRIBE TO DRAW LINE. MARRING THE METAL CAN CAUSE CORROSION.

NOTE: For ease of accessibility, sub-paragraph (3) (a) may be accomplished before supporting aileron on balancing device.

AA-5 SERIES
MAINTENANCE MANUAL

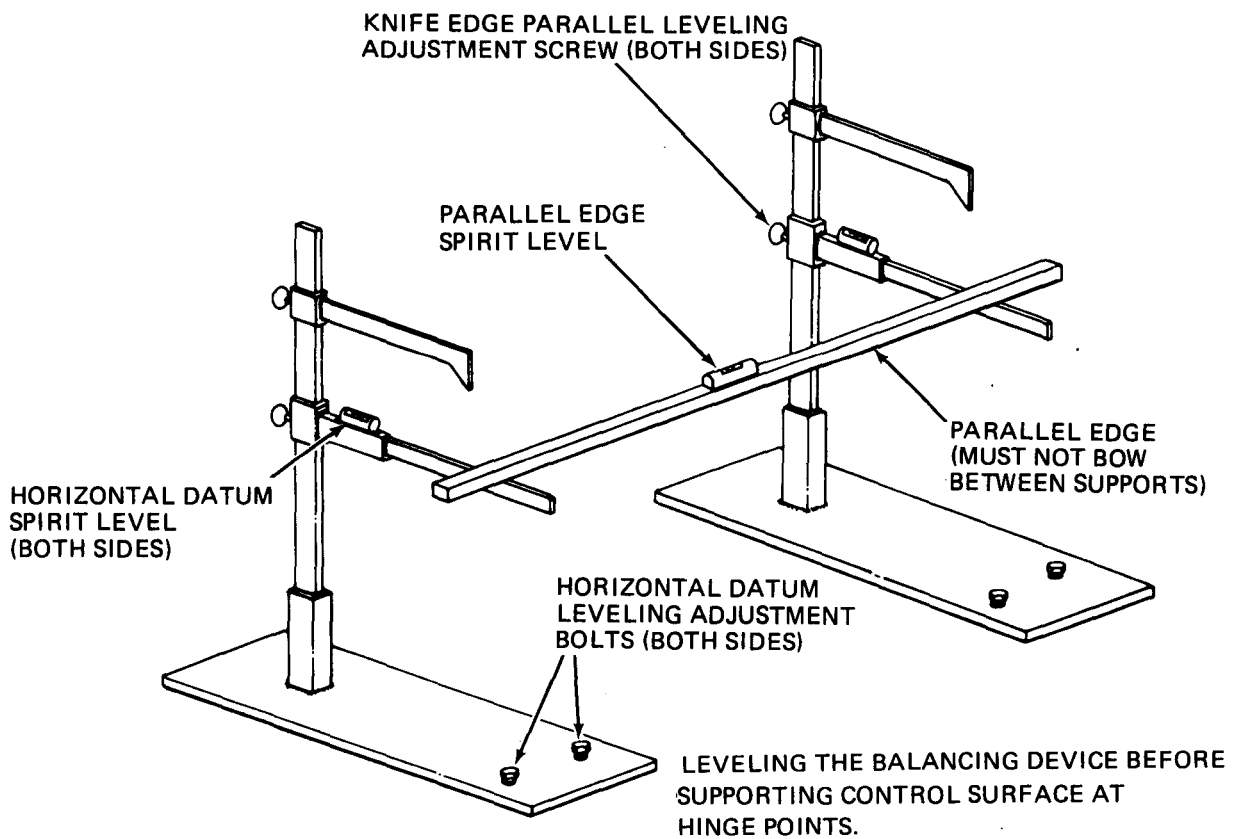
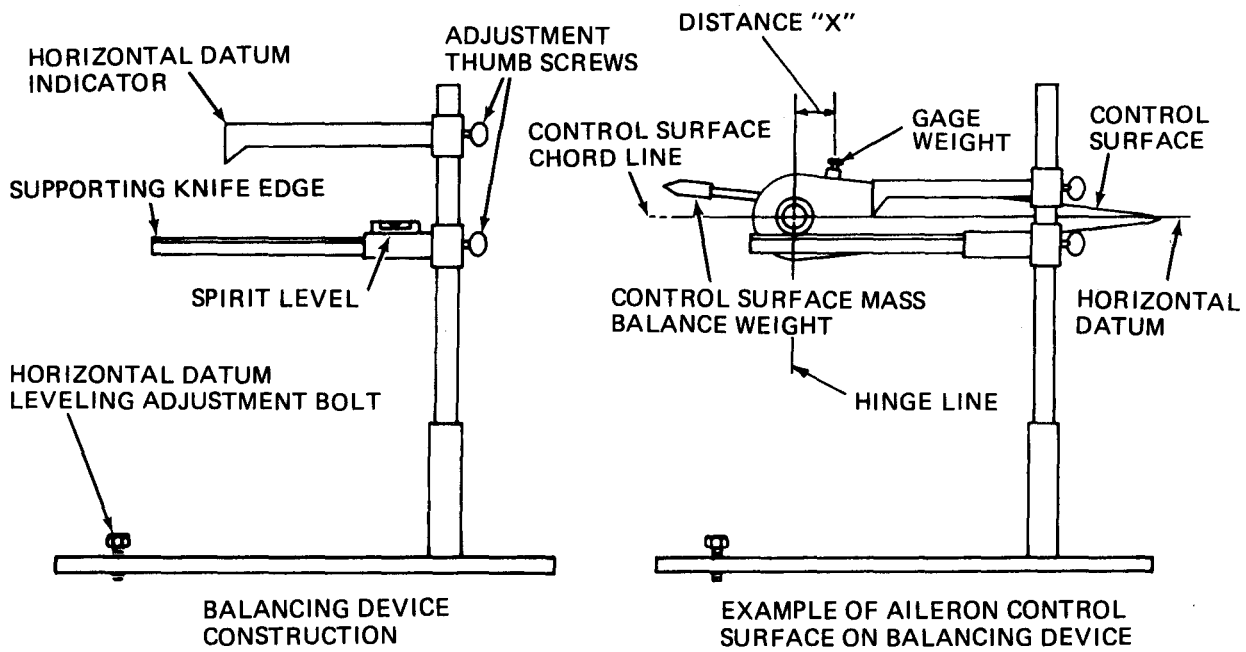

Typical Control Surface Balancing Device
Figure 503

3887

AA-5 SERIES
MAINTENANCE MANUAL

- (b) measure the distance from the top edge of the support knife to the center of the torque tube. Then set the horizontal datum indicator by measuring the same distance from the top edge of the support knife to the tip of the indicator pointer.
- (4) Check Aileron to see if it is nose heavy or tail heavy.
 - (a) If Aileron is nose heavy, start balance test by placing gage weight on aileron on aileron surface aft of hinge line.
 - (b) If Aileron is tail heavy, start balance test by placing gage weight on aileron surface forward of hinge line.
- (5) Move gage weight until chord line is horizontally level as pointed out by horizontal datum indicator.
- (6) Measure and record the distance (X) from the hinge centerline to the gage weight. The gage weight must be within the distance limits given in Table 1.
- (7) If gage weight is forward of the distance limits given in Table 1 (underbalance condition), the mass balance weight assembly must be replaced. This assembly is designed to provide a slight over-balance to allow balancing by removal of weight.

NOTE: If it is necessary to move the gage weight forward of the hinge line, attach string or fine wire to the gage weight and loop it over the mass balance weight support tube.

- (8) If gage weight is aft of the distance limits given in Table 1 (overbalance condition), remove weight from aileron mass balance weight until aileron balances by:
 - (a) shaving away lead material from top and bottom of weight, (Maximum 0.125 inch), or;
 - (b) drilling holes in either side of weight (Maximum depth 0.38 inch).

D. Elevator Balancing (See Figure 503 and 505)

NOTE: Elevator extension and tip cap on AA-5 models and tip cap on AA-5A/AA-5B models and attaching hardware must be installed on elevator before balancing is accomplished.

- (1) Level the balancing device.
- (2) Support the elevator on the knife edges of the balancing device at both ends of the hinge line.

NOTE: Balance each elevator separately.

- (a) AA5 Models - The torque tube is the hinge line.
- (b) AA-5A/AA-5B Models - Install hinge bolts at the inboard and outboard hinge points.
- (3) Provide elevator chord line/horizontal datum reference as follows:
 - (a) place a light mark through the center of the torque tube (AA-5 models) or hinge point bolt hole (AA-5A/AA-5B models) and through the center of the elevator trailing edge.

CAUTION: DO NOT USE A SCRIBE TO DRAW LINE. MARRING THE METAL CAN CAUSE CORROSION.

NOTE: For ease of accessibility, sub-paragraph (3) (a) may be accomplished before supporting elevator on balancing device.

- (b) measure the distance from the top edge of the support knife to the center of the torque tube (AA-5 Models) or center of the hinge point bolt hole (AA-5A/AA-5B models). Then set the horizontal datum indicator by measuring the same distance from the top of the support knife to the tip of the indicator pointer.

AA-5 SERIES
MAINTENANCE MANUAL

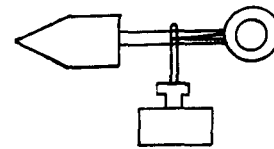
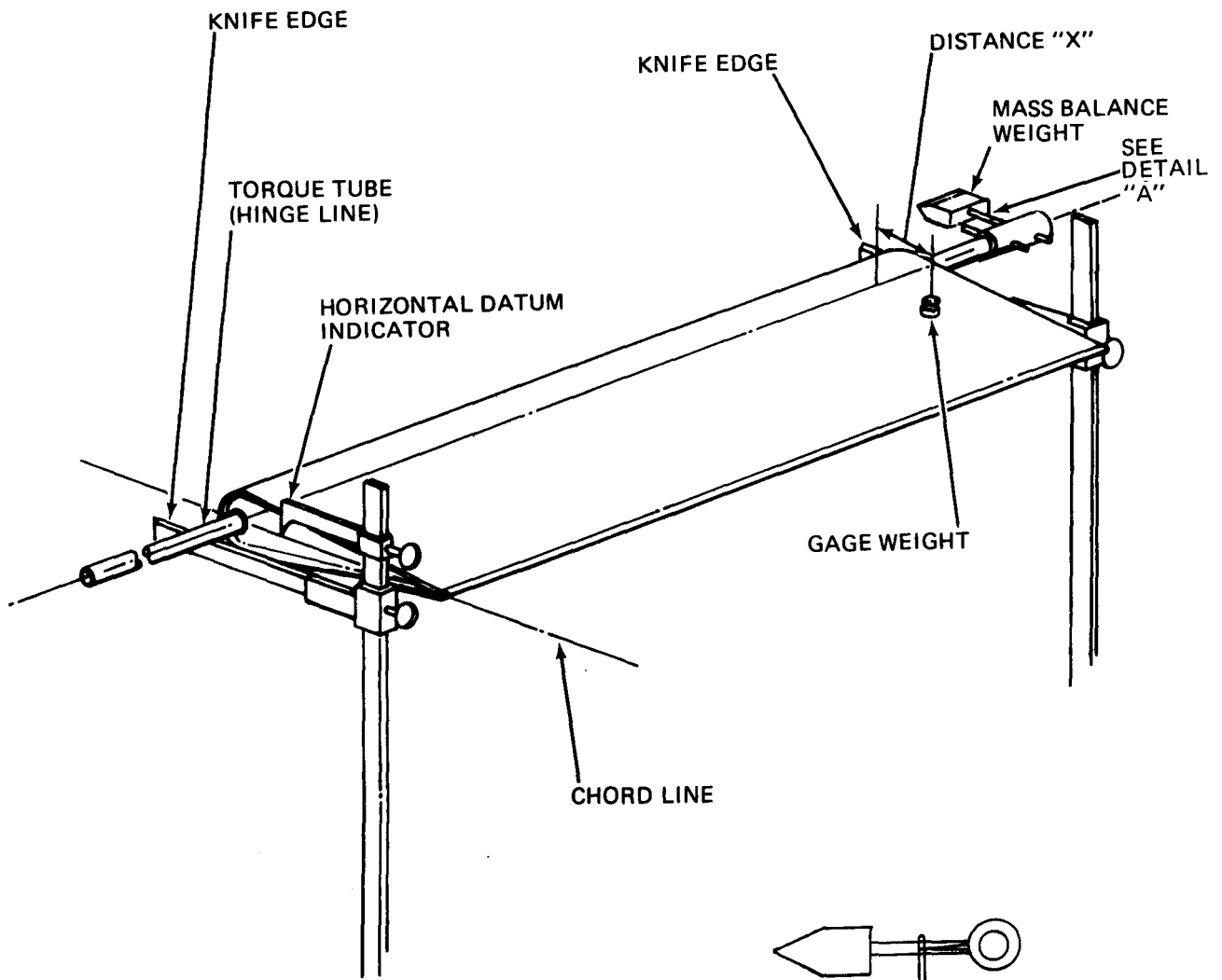

DETAIL A

EXAMPLE OF GAGE WEIGHT LOOPED OVER MASS BALANCE WEIGHT. SUPPORT TUBE WHEN NECESSARY TO MOVE GAGE WEIGHT FORWARD OF HINGE LINE.

Typical Aileron Balancing
Figure 504

3888

AA-5 SERIES
MAINTENANCE MANUAL

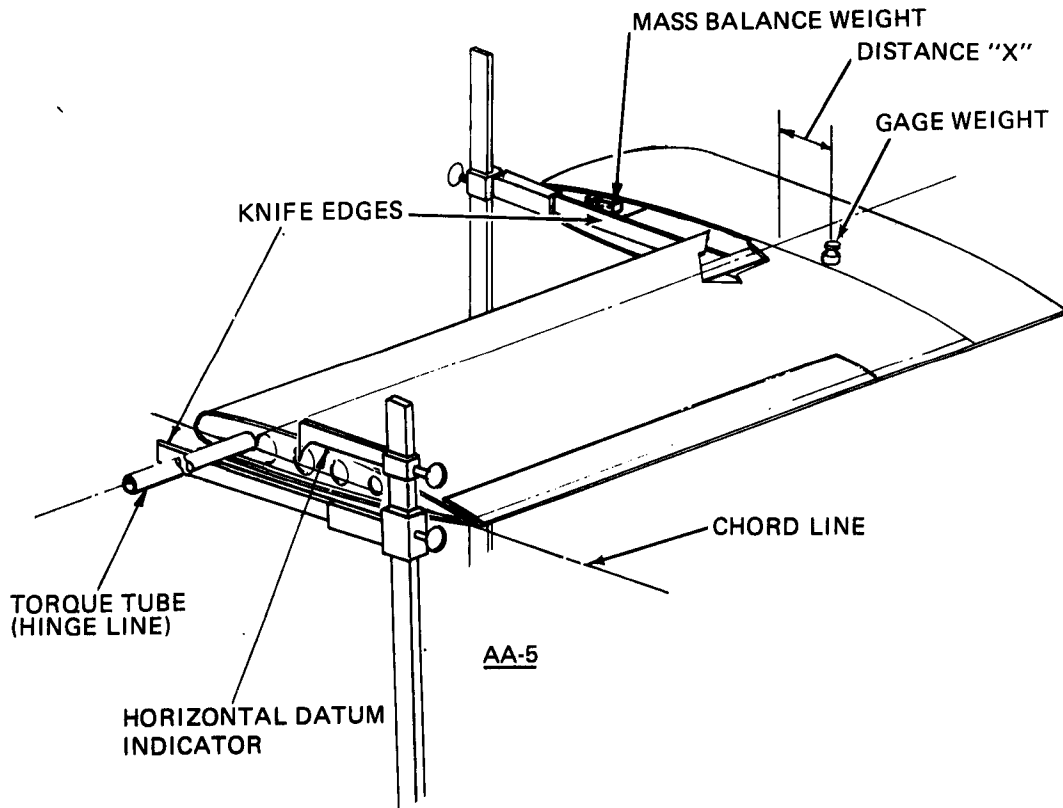
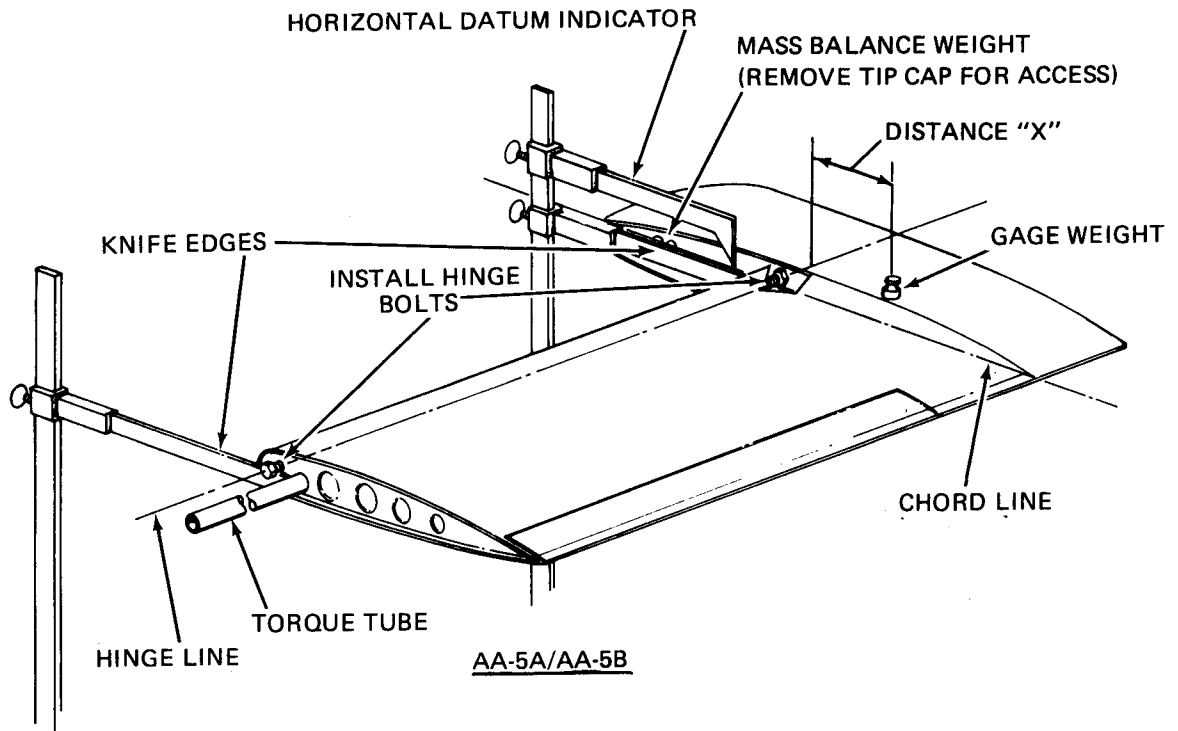

Typical Elevator Balancing
Figure 505

3889

**AA-5 SERIES
MAINTENANCE MANUAL**

- (4) Check elevator to see if it is nose heavy or tail heavy.
 - (a) If elevator is nose heavy, start balance test by placing gage weight on elevator surface aft of hinge line.
 - (b) If elevator is tail heavy, start balance test by placing gage weight on elevator surface forward of hinge line.
- (5) Move gage weight until chord line is horizontally level as pointed out by horizontal datum indicator.
- (6) Measure and record the distance (X) from the hinge center line to the gage weight. The gage weight must be within the distance limits given in Table 1.
- (7) If gage weight is forward of the distance limits given in Table 1 (underbalance condition), the mass balance weight must be replaced with a heavier weight.
 - (a) AA-5 Models - Mass balance weight is accessible without removal of elevator extension and tip cap.
 - (b) AA-5A/AA-5B Models - Remove elevator tip cap to gain access to mass balance weight. Tip cap must be reinstalled before determining new balance.
- (8) If gage weight is aft of the distance limits given in Table 1 (overbalance condition), remove weight from elevator mass balance weight by drilling or shaving away lead weight material to bring elevator within balance limits.

NOTE: AA-5A/AA-5B Models - Tip cap must be reinstalled before determining new balance. It is unnecessary to remove the elevator extension and tip cap on AA-5 Models during mass balance weight rework.

E. Rudder Balancing (See Figure 503 and 506)

NOTE: Rudder tip cap, flashing beacon (optional equipment) and all attaching hardware must be installed on rudder before balancing is accomplished. If equipped with optional flashing beacon, route wire through torque tube to assure that it does not interfere with, or influence balancing procedure.

- (1) Level the balancing device.
- (2) Support the rudder on the knife edges of the balancing device at both ends of the hinge line.

NOTE: The torque tube is the hinge line of the rudder.

- (3) Provide rudder chord line/horizontal datum reference as follows:
 - (a) place a light mark through the center of the torque tube and the center of the rudder trailing edge.

CAUTION: DO NOT USE A SCRIBE TO DRAW LINE. MARRING THE METAL CAN CAUSE CORROSION.

NOTE: For ease of accessibility, sub-paragraph (3) (a) may be accomplished before supporting rudder on balancing device.

- (b) measure the distance from the top edge of the support knife to the center of the torque tube. Then set the horizontal datum indicator by measuring the same distance from the top of the support knife to the tip of the indicator pointer.
- (4) Check rudder to see if it is nose heavy or tail heavy.
 - (a) If rudder is nose heavy, start balance test by placing gage weight on rudder surface aft of hinge line.

AA-5 SERIES
MAINTENANCE MANUAL

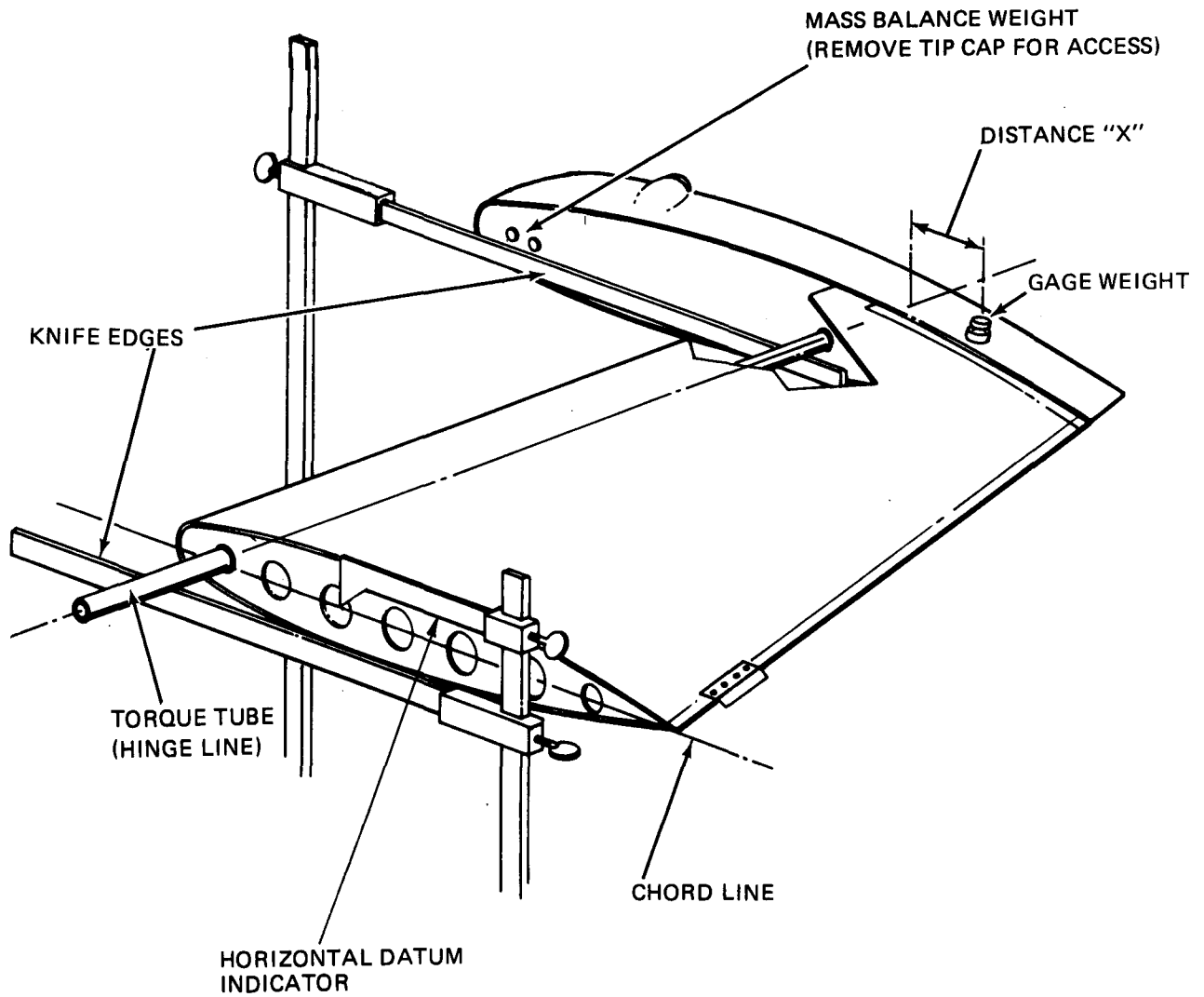

Typical Rudder Balancing
Figure 506

3890

AA-5 SERIES
MAINTENANCE MANUAL

- (b) If elevator is tail heavy, start balance test by placing gage weight on rudder surface forward of hinge line.
- (5) Move gage weight until chord line is horizontally level as pointed out by horizontal datum indicator.
- (6) Measure and record the distance (X) from the hinge center line to the gage weight. The gage weight must be within the distance limits given in Table 1.
- (7) If gage weight is forward of the distance limits given in Table 1 (underbalance condition), the mass balance weight must be replaced with a heavier weight.
 - (a) Remove rudder tip cap to gain access to mass balance weight. Tip cap must be reinstalled before determining new balance.
- (8) If gage weight is aft of the distance limits given in Table 1 (overbalance condition), remove weight from rudder mass balance weight by drilling or shaving away lead weight material to bring rudder within balance limits.

NOTE: Tip cap must be reinstalled before determining new balance.

AA-5 SERIES
MAINTENANCE MANUAL

MAINTENANCE PRACTICES - CLEANING/PAINTING

1. General

CAUTION: WHEN CONTROL SURFACES ARE PAINTED THEIR BALANCE IS CHANGED. ALWAYS CHECK BALANCE AFTER PAINTING.

Clean and paint the ailerons in accordance with Chapter 20.

RUDDER & TAB - DESCRIPTION/OPERATION

1. General (See Figure 1.)

The rudder system is composed of dual rudder pedals, which are center loaded by centering springs, cables which extend from the rudder pedals to the rudder, and a rudder actuated by a bellcrank attached to the cables. Adjustable rudder stops are provided to limit rudder travel to that required for proper control.

The rudder assembly (Figure 2) is a bonded structure composed of a torque tube, four honeycomb ribs, a skin, and a tip. The ribs are bonded to both the torque tube and the skin, to form a rigid structure that can be positioned by the torque tube. A fixed, ground adjustable trim tab is riveted to the lower trailing edge of the rudder. The rudder is supported by two bearings, one at the base of the rudder, and the other between the top honeycomb rib and the tip. The rudder tip is supported by a rib assembly that is attached to the torque tube and the top honeycomb rib. This rib assembly also provides a mounting point for the rudder mass balance. The plastic rudder tip is attached to the rib by speed nuts and screws. The control horn is attached to the rudder torque tube beneath the bottom hinge.

AA-5 SERIES
MAINTENANCE MANUAL

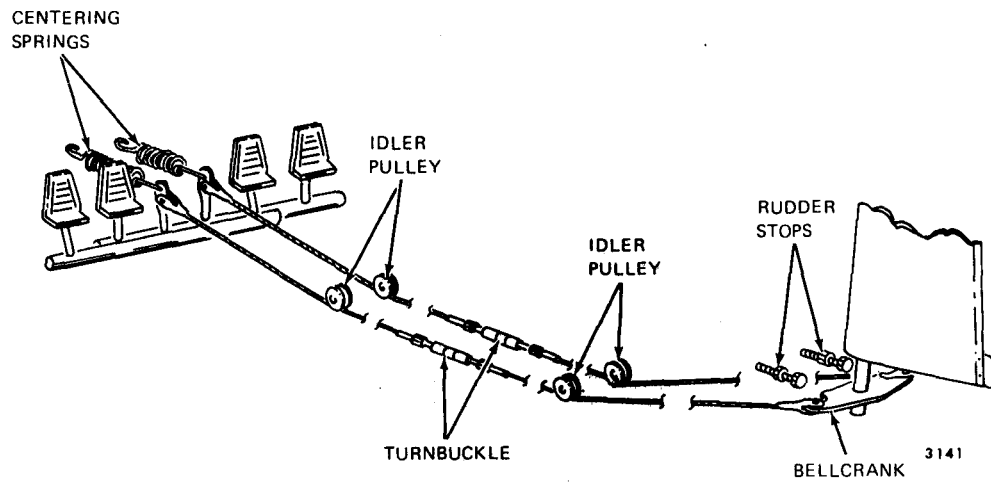

Rudder System
Figure 1

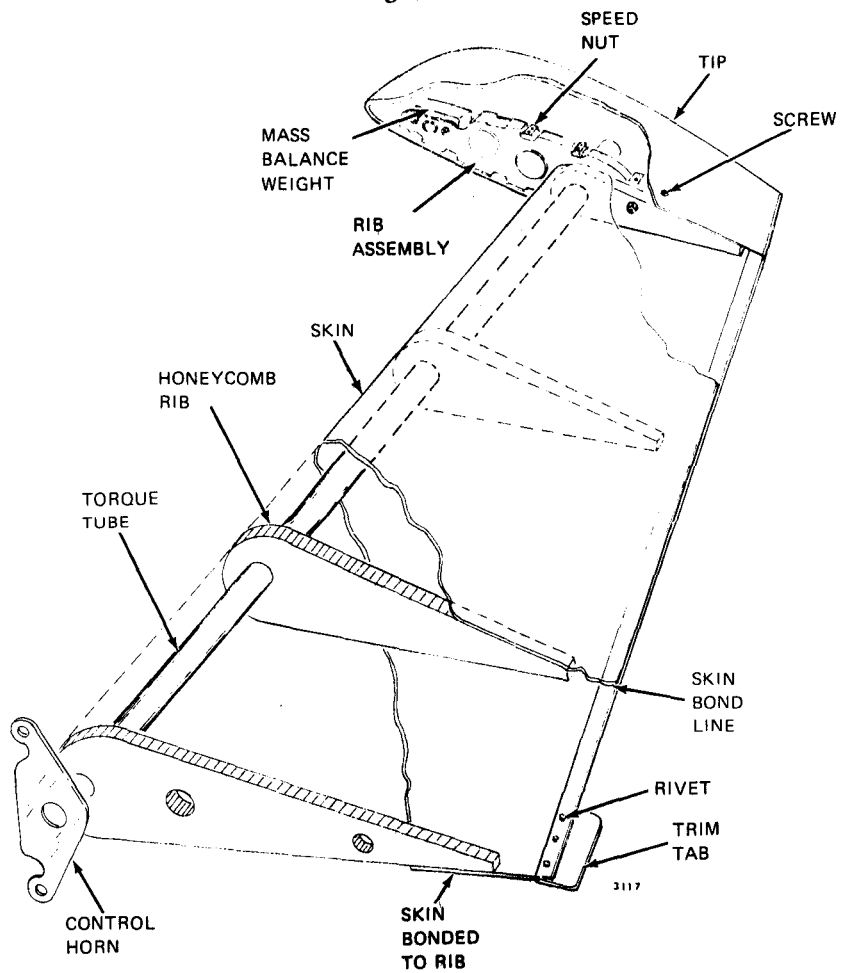

Rudder Assembly
Figure 2

MAINTENANCE PRACTICES – SERVICING

1. Lubrication

A. Rudder Bearing Lubrication

Apply MIL-L-7870 (See Chapter 12) oil to the torque tube and rudder bearings. Also apply MIL-L-7870 (See Chapter 12) oil to the rudder control horn clevis bolts.

B. Rudder Pedal Lubrication

Apply MIL-L-7870 (See Chapter 12) oil to the rudder pedal bearings.

MAINTENANCE PRACTICES — REMOVAL/INSTALLATION

1. Rudder Removal/Installation

A. Rudder Removal (See Figure 401.)

- (1) Remove tailcone per Chapter 53.
- (2) Remove ELT access panel per Chapter 53.
- (3) Remove nut (1), washers (2) and bolt (3) from bellcrank (4).
- (4) Hold rudder deflected and remove screw (5) from top hinge (6).
- (5) Hold rudder deflected in the opposite direction and remove the other screw (5) from top hinge (6).
- (6) Disconnect BNC connector (7) by twisting counterclockwise and pulling apart.
- (6) Disconnect electrical connector (8) by pulling apart. Disconnect ground strap.
- (7) Lift rudder (9) until its torque tube (10) clears bottom spacer (11) bellcrank (4) and hinge (12).
- (8) Remove top spacer (13) from torque tube (10).
- (9) Slowly remove rudder while feeding wire bundle (14) through the vertical fin until it clears.

B. Rudder Installation (See Figure 401.)

- (1) Position rudder such that wire bundle (14) can be fed through access hole in vertical fin. Feed wire bundle through bottom of vertical fin. Connect ground strap.
- (2) Place upper spacer (13) on torque tube (10).
- (3) Slide torque tube (10) through hinge (12).
- (4) Place bottom spacer (11) on torque tube and align holes.
- (5) Insert bellcrank tube (4) in torque tube and align holes.
- (6) Secure with bolt (3), washers (2) and nut (1). Torque per Chapter 91.
- (7) Hold rudder deflected and install screw (5) through top hinge (6). Hold rudder deflected in the other direction and install screw (5) in hinge (6).
- (8) Connect BNC connector (7) by inserting male end into female end, pressing together, and turning clockwise into detent.
- (9) Connect electrical connector (8) by pressing two halves together.
- (10) Install ELT access panel per Chapter 53.
- (11) Install tailcone per Chapter 53.
- (12) Check controls for freedom of movement.
- (13) Check operation of flashing beacon.
- (14) Check rudder tip fin clearance per Rudder Tip-Fin Clearance Adjustment paragraph.

AA-5 SERIES
MAINTENANCE MANUAL

1. NUT
2. WASHER
3. BOLT
4. BELLCRANK
5. SCREW
6. HINGE
7. CONNECTOR
8. CONNECTOR
9. RUDDER
10. TORQUE TUBE
11. SPACER
12. HINGE
13. SPACER
14. CONTROL STOP

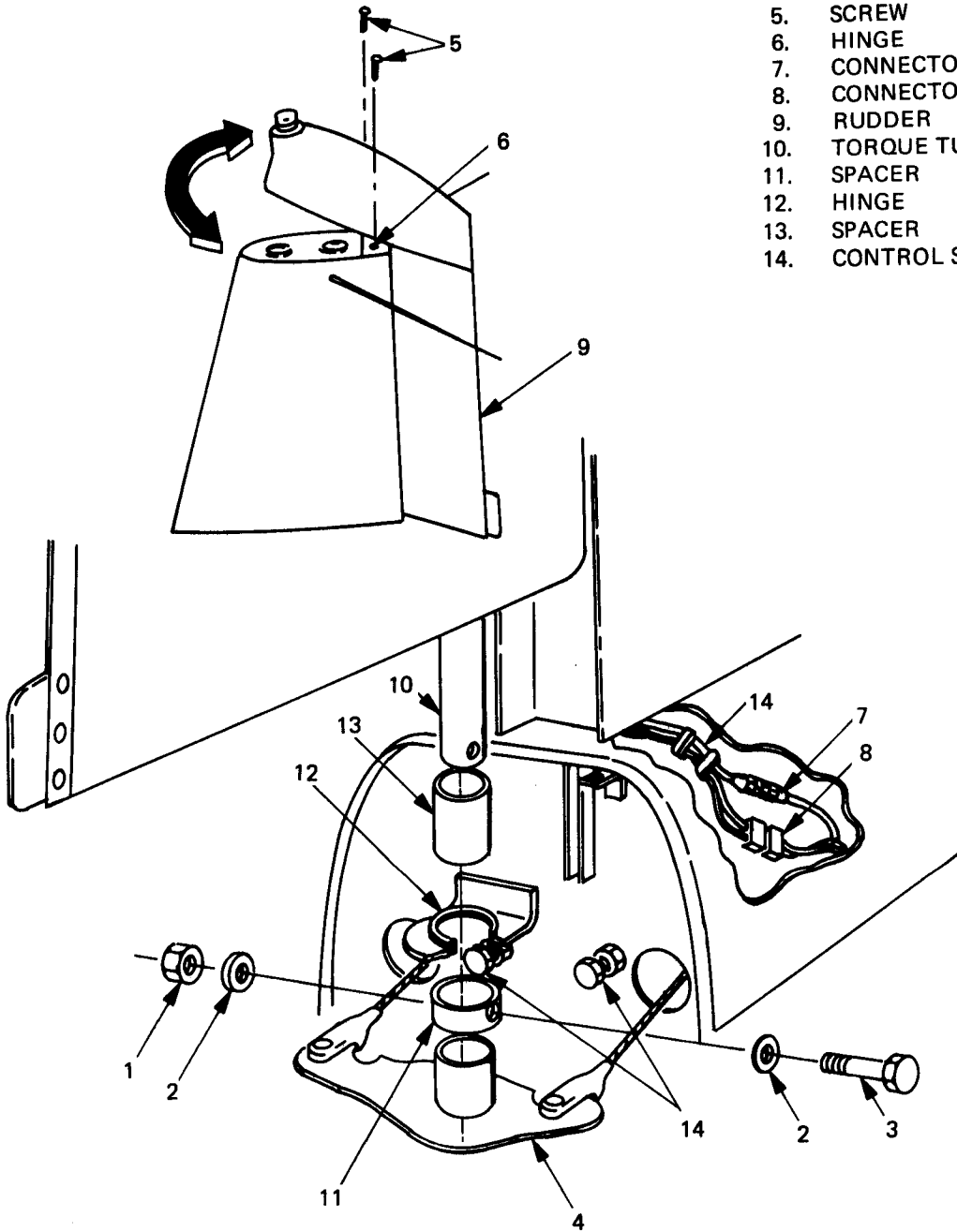

Rudder Removal/Installation
Figure 401

2. Rudder Pedal Removal/Installation

A. Rudder Pedal Removal (See Figure 402.)

- (1) Remove cotter pin (1), washer (2), and clevis pin (3) from brake (4), and remove rudder pedal linkage (5) from brake (4).
- (2) Depress left rudder pedal and disconnect left return spring (6) from control horn (7).
- (3) Disconnect right return spring (8) from control horn (7).
- (4) Remove return springs (6) and (8) from eye bolts (9).
- (5) Remove cotter pins (10), nuts (11) and washers (12) from clevis bolts (13), and remove rudder cables (14) from control horns (7).
- (6) Remove nuts (15) and washers (16) from mounting bolts (17), and lift bearing assembly (18) from bolts (17).
- (7) Remove bearing assemblies (18).
- (8) Disconnect hydraulic lines (19) from elbow (20) on rudder bar assembly (21) and remove brake lines (22). Cap all open lines.
- (9) Pull the rudder bar assemblies (21) laterally until they clear the bearings (18) on the right side, and remove the rudder bar assemblies (21).

B. Rudder Pedal Installation (See Figure 402.)

- (1) Install a bearing assembly (18) in the left end of each rudder bar assembly (21).
- (2) Position the rudder bar assemblies (21) such that their open ends slide over the bearings on the right side of the aircraft.
- (3) Place the bearing assemblies (18) on the left ends of the rudder bar assemblies (21) so that they fit over the mounting bolts (17) in the floor of the aircraft. Secure with washers (16) and nuts (15), and torque to standard value. (See Chapter 91.)
- (4) Connect hydraulic lines (19) to elbow fittings (20) and torque to standard value. (See Chapter 91.)
- (5) Position rudder cable clevises (14) over control horns (7) and secure with clevis bolts (13), washers (12), nuts (11) and cotter pins (10).
- (6) Hook return springs (6) and (8) into eye bolts (9).
- (7) Depress left rudder pedal and hook return spring (6) into control horn (7).
- (8) Depress right rudder and connect return spring (8) to control horn (7).
- (9) Place rudder pedal brake arms (5) in slot in top of brake (4). Secure with clevis pin (3), washer (2) and cotter pin (1).
- (10) Bleed brakes per Chapter 32.
- (11) Rig rudder controls per Rudder Pedal Rigging paragraph.

**AA-5 SERIES
MAINTENANCE MANUAL**

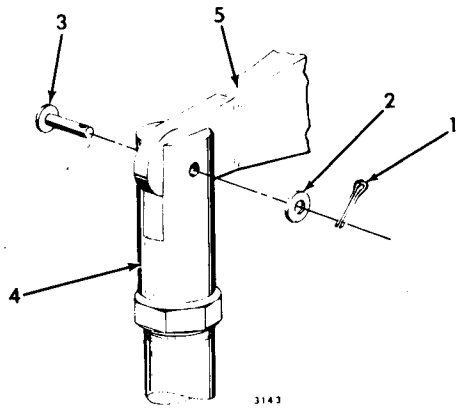

DETAIL A

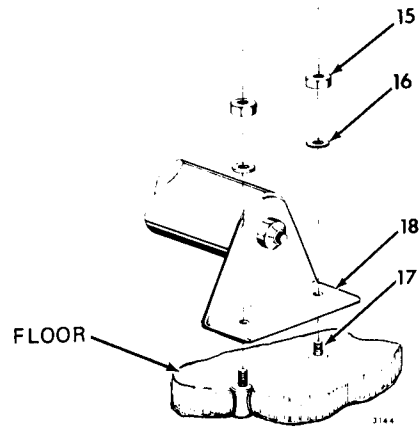

DETAIL B

- 1. Cotter Pin
- 2. Washer
- 3. Clevis Pin
- 4. Brake
- 5. Rudder Pedal Linkage
- 6. Spring
- 7. Control Horn
- 8. Spring
- 9. Eye Bolt
- 10. Cotter Pin
- 11. Nut

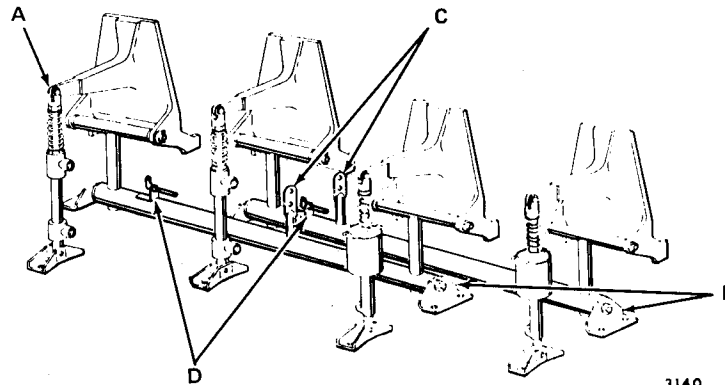

- 12. Washer
- 13. Clevis Bolt
- 14. Rudder Cable
- 15. Nut
- 16. Washer
- 17. Bolt
- 18. Bearing
- 19. Hydraulic Line
- 20. Elbow
- 21. Rudder Bar
- 22. Brake Line

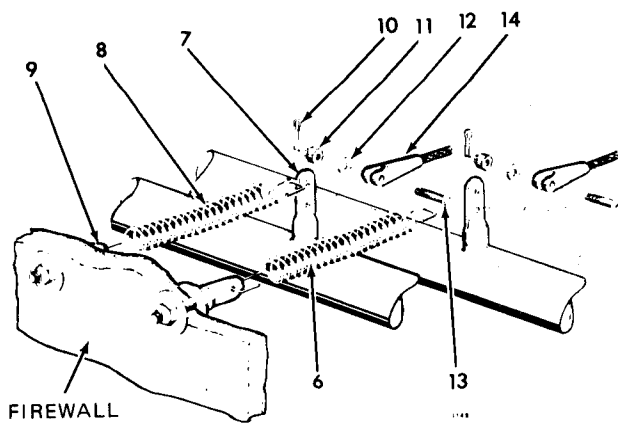

DETAIL C

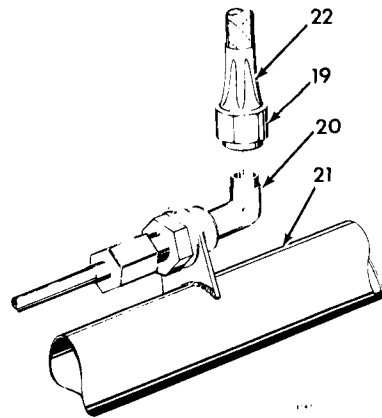

**DETAIL D
ROTATED 90°**

**Rudder Pedal Removal/Installation
Figure 402**

3. Rudder Cable Removal/Installation

A. Rudder Cable Removal (See Figure 403.)

- (1) Remove tailcone per Chapter 53.
- (2) Remove cotter pins (1), nuts (2), washers (3), and clevis bolts (4) from cable clevises (5).
- (3) Remove cable clevises (5) from rudder bellcrank (6) and allow cables (7) to move forward into fuselage.
- (4) Remove cotter pin (8) from guard (9) and remove guard (9) from pulley assembly (10).
- (5) Pull cables (7) from under pulley assembly (10).
- (6) Remove nuts (11), and washers (12) from studs (13) in aircraft floor (14) and lift pulley assembly (15) to clear cables (7).
- (7) Pull cables (7) from under pulley assembly (15).
- (8) Remove cotter pins (16), nuts (17), washers (18), and clevis bolts (19) from cable clevis ends (20).
- (9) Remove clevis ends (20) from control horns (21) and remove cables (7) from aircraft.

B. Rudder Cable Installation (See Figure 403.)

NOTE: If new cables are being installed, lubricate them with commercial grade paraffin before installation.

- (1) Each rudder cable is composed of a short cable (forward cable) and a long cable (aft cable) joined by a turnbuckle. Select the clevis end (5) of the long cable and attach it to the rudder bellcrank (6) with clevis bolt (4), washer (3), nut (2), and cotter pin (1). Attach both rudder cables to the bellcrank (6).
- (2) Feed both cables (7) into the fuselage and route them so that they engage the pulleys (22) on the pulley assembly (10).
- (3) While holding the cables (7) in the pulleys (22), install guard (9) and secure it with cotter pin (8).
- (4) Route the cables beneath the spar center section, and through the pulleys on the pulley assembly (15).
- (5) While holding cables in the pulleys, install pulley assembly (15) over studs (13). Secure with washers (12) and nuts (11). Torque to standard values. (See Chapter 91.)
- (6) Place cable clevises (20) over control horns (21); align holes, and secure with clevis bolts (19), washers (18), nuts (17), and cotter pins (16).
- (7) Rig rudders per Adjustment/Test, Paragraph 1, this chapter.
- (8) Install tailcone per Chapter 53.

4. Rudder Bearing Removal/Installation

A. Remove the rudder as described in Paragraph 1 above.

B. The rudder bearings are located in the hinges (6 and 12, Figure 401), and are removed and installed in the same manner as the aileron bearings. Refer to Section 27-1-1.

5. Rudder Bearing Wear Limits

Refer to Section 27-1-1, paragraph entitled "Aileron Bearing Wear Limits."

**AA-5 SERIES
MAINTENANCE MANUAL**

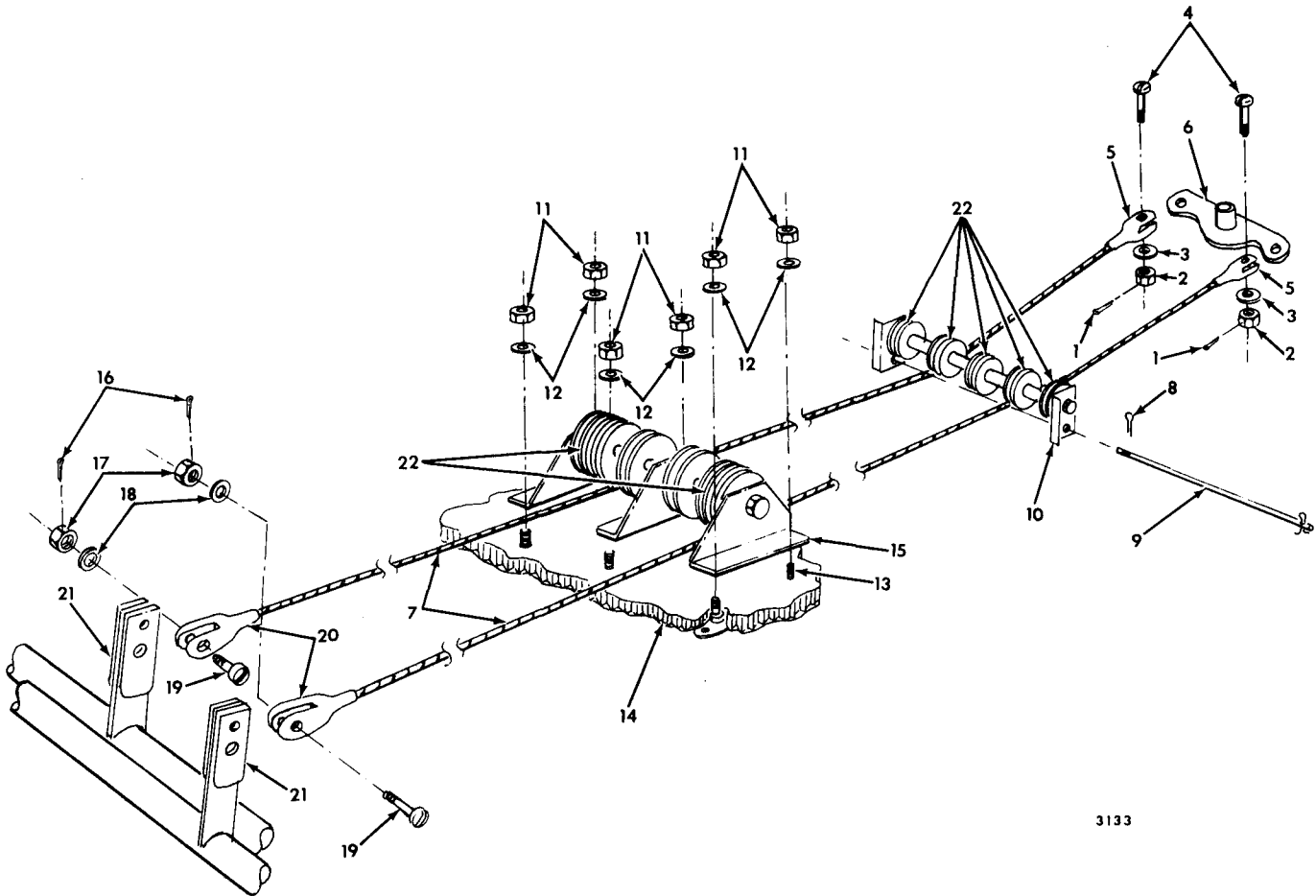

3133

- | | |
|---------------------|---------------------|
| 1. Cotter Pin | 12. Washers |
| 2. Nut | 13. Studs |
| 3. Washer | 14. Aircraft Floor |
| 4. Clevis Bolt | 15. Pulley Assembly |
| 5. Cable Clevis | 16. Cotter Pins |
| 6. Bellcrank | 17. Nuts |
| 7. Cables | 18. Washers |
| 8. Cotter pin | 19. Clevis Bolts |
| 9. Guard | 20. Cable Clevis |
| 10. Pulley Assembly | 21. Control Horn |
| 11. Nuts | 22. Pulleys |

**Rudder Cable Removal/Installation
Figure 403**

**AA-5 SERIES
MAINTENANCE MANUAL**

6. Rudder Bellcrank and Torque Tube Repair

Excessive play in the rudder control system can be caused by slippage at the rudder bellcrank and rudder torque tube. In certain high-time, in-service aircraft, this condition has been traced to enlargement or elongation of the attach holes in the rudder torque tube (10, Figure 401) at the rudder bellcrank (4).

The following is an acceptable repair from a structural standpoint:

- A. Remove tail cone assembly. Refer to Chapter 53.
- B. Hold the rudder bellcrank (4, Figure 401) firmly against one of the rudder control stops (14). Grasp the rudder (9) at the trailing edge and attempt to rotate the rudder torque tube (10) in both directions. (The torque tube is an integral part of the rudder.)
- C. If play is noted, determine the largest diameter of the rudder torque tube and rudder bellcrank bolt holes.
- D. If the largest diameter exceeds 0.2505 inch, open the existing bolt holes in the rudder torque tube and rudder bellcrank to 0.312 to 0.315 inch diameter.

NOTE: Do not increase the hole size beyond that specified. If the holes will not clean up, the rudder bellcrank and rudder must be replaced. If removal for repair/replacement is necessary, Refer to Maintenance Practices - Removal/Installation, Paragraphs 1 and 3, this section.

- E. If existing bolt holes are opened in accordance with sub-paragraph D above, install oversize attach hardware listed below.

| | |
|-------------|---------|
| NAS464P5A23 | Bolt |
| AN960-516 | Washers |
| MS20364-524 | Nut |

- F. If repair or replacement is made, perform rudder rigging check. Refer to Adjustment/Test, Paragraph 1, this section, for rigging procedures.
- G. Record the Repair/Replacement in the aircraft log.

MAINTENANCE PRACTICES — ADJUSTMENT/TEST

1. Rudder Rigging

A. Return Tension Adjustment (See Figure 501.)

- (1) Remove tailcone per Chapter 53.
- (2) Remove trim per Chapter 25, as required to gain access to rudder turnbuckles.
- (3) Hold rudder centered so that it aligns with top of vertical fin, and clamp phenolic blocks to rudder bellcrank as shown in Figure 501 so that rudder is held in alignment.
- (4) Loosen rudder cable turnbuckles.
- (5) Place a 7 inch wooden block between each pilot rudder pedal and the firewall, as shown in Figure 501.
- (6) Slowly tighten rudder turnbuckles (each by same amount) until one or both wooden blocks fall from behind rudder pedals.
- (7) Safety rudder turnbuckles.
- (8) Remove clamps and blocks from bellcrank.
- (9) Install tailcone per Chapter 53
- (10) Reinstall removed trim per Chapter 25.

B. Rudder Travel Adjustment (See Figure 502.)

- (1) Remove tailcone per Chapter 53.
- (2) Position rudder rigging fixture (DE-0002-501) on vertical fin as shown in Figure 502.
- (3) Loosen control stop lock nut on each control stop.
- (4) Depress left rudder pedal to its stop, and adjust left control stop until rudder rigging fixture indicates $25^{\circ} \pm 2^{\circ}$ rudder deflection to the left.
- (5) Hold control stop and tighten lock nut.
- (6) Repeat Steps (4) and (5) for the right hand side.
- (7) Install tailcone per Chapter 53.

C. Rudder Tip-Fin Clearance Adjustment (See Figure 503.)

- (1) Inspect rudder for proper clearance (0.10 inch minimum) between rudder tip and vertical fin.
- (2) If insufficeint clearance exists, remove rudder per Removal/Installation, Paragraph 1.
- (3) Remove screws (1), and rudder tip (2).
- (4) Remove nut (3) and washer (4).
- (5) Remove nut (5), washer (6) and bolt (7) from torque tube, and lift rib (8) from rudder (9).

AA-5 SERIES
MAINTENANCE MANUAL

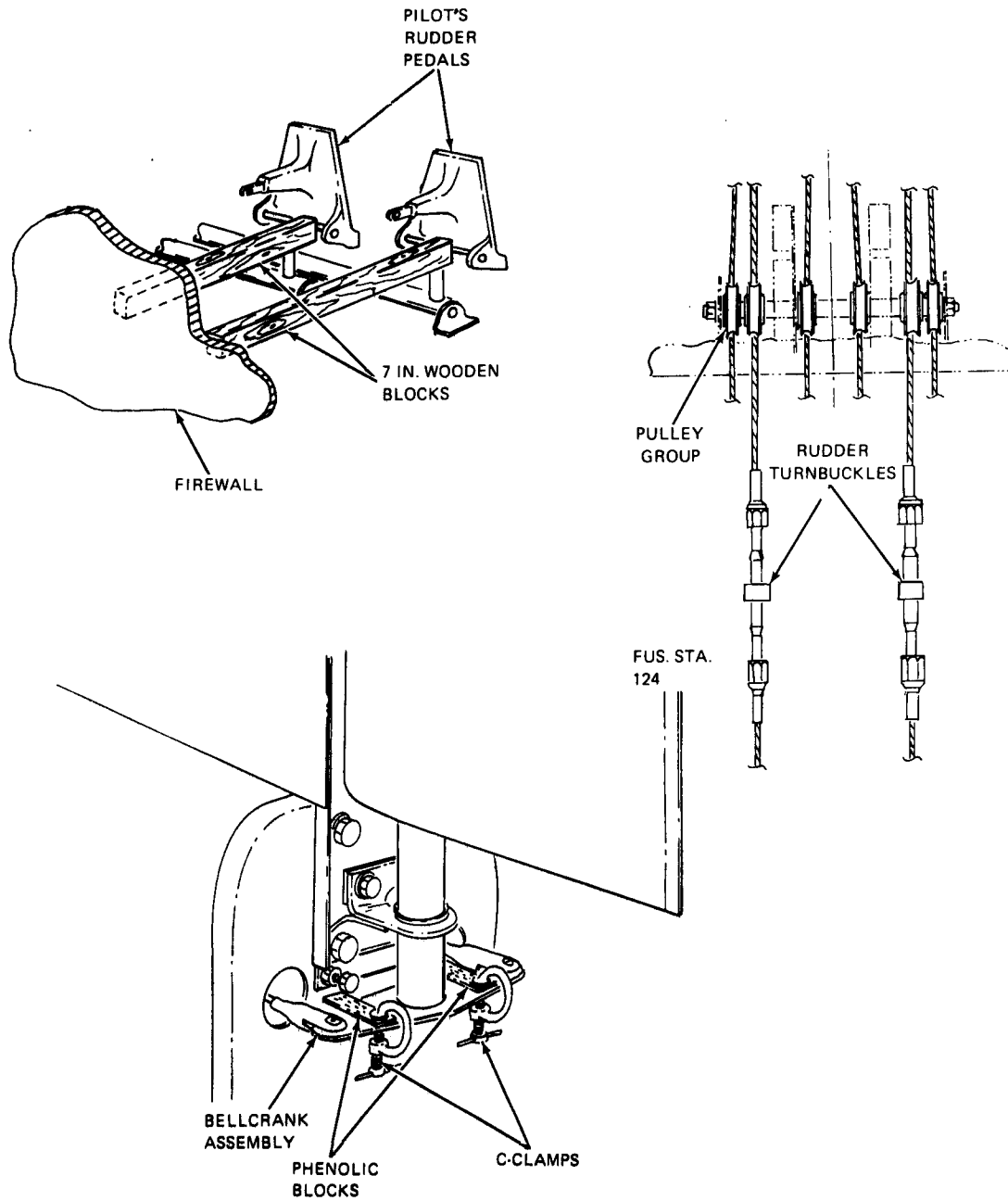

Rudder Return Tension Adjustment
Figure 501

AA-5 SERIES
MAINTENANCE MANUAL

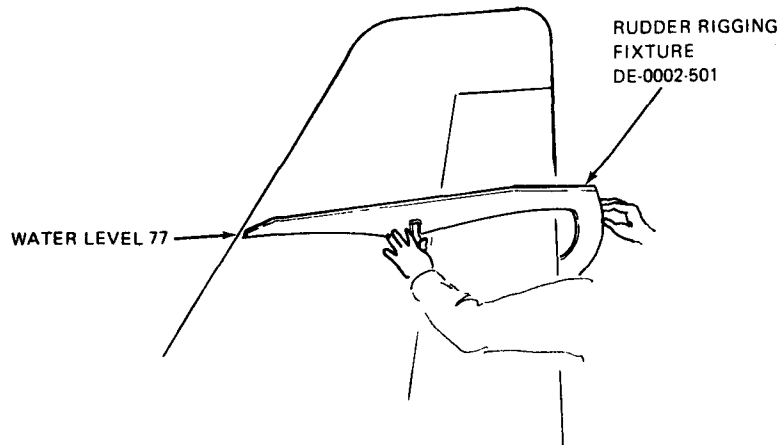
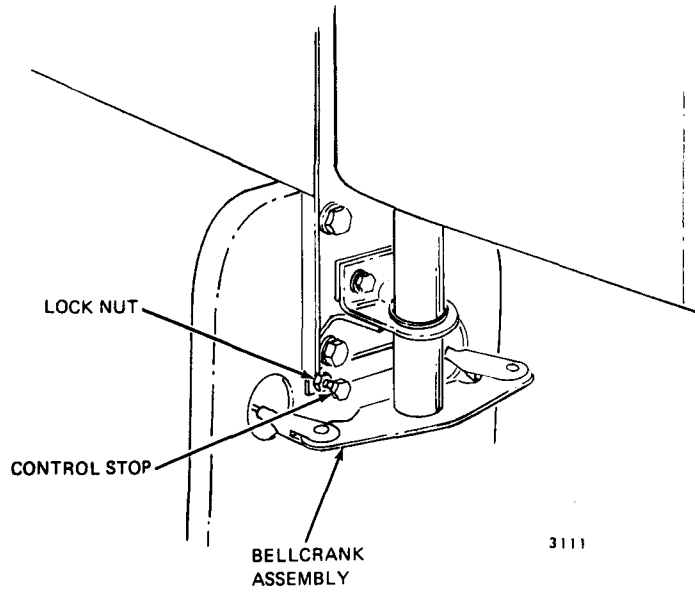

Rudder Travel Adjustment
Figure 502

**AA-5 SERIES
MAINTENANCE MANUAL**

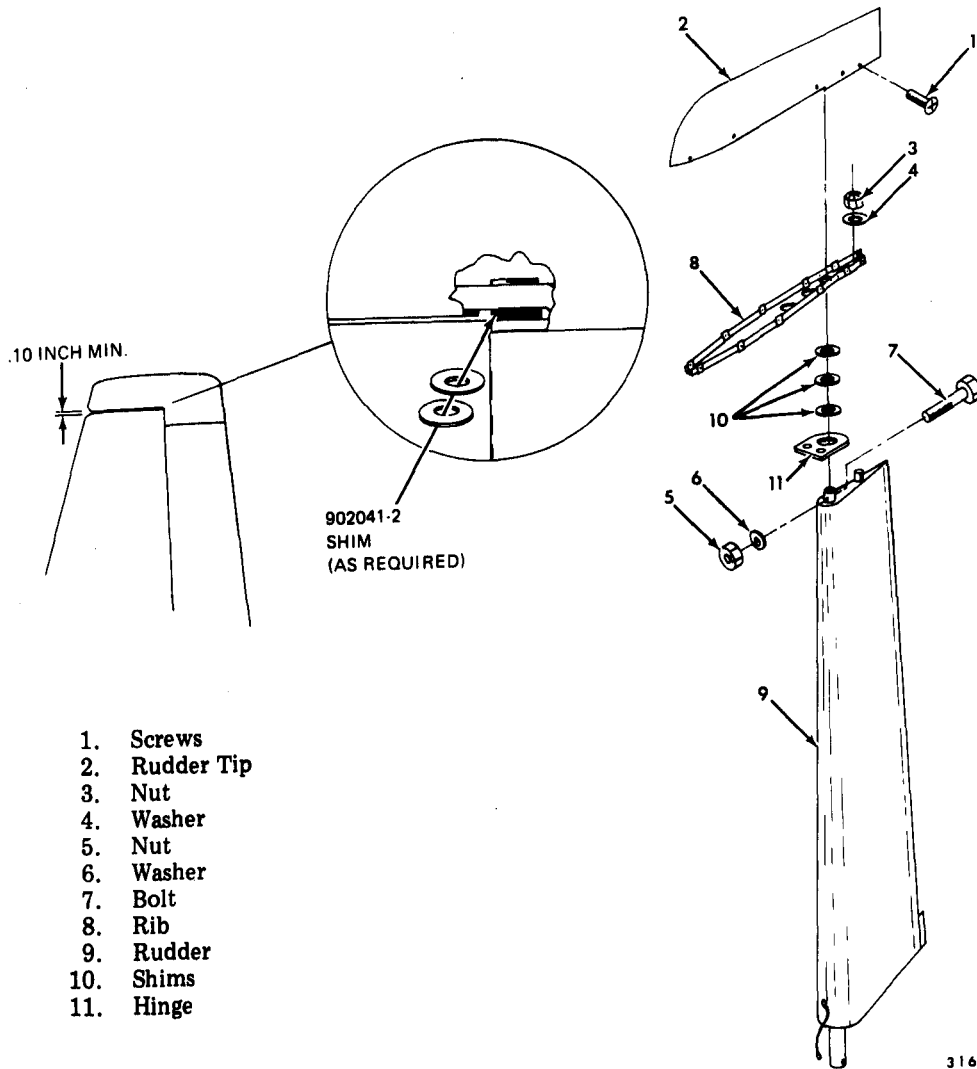

**Rudder Tip-Fin Clearance Adjustment
Figure 503**

AA-5 SERIES
MAINTENANCE MANUAL

- (6) Place shims (10) on torque tube between hinge (11) and rib (8), to achieve the required clearance.
- (7) Place rib (8) on rudder (9) and secure with washer (4), nut (3), bolt (7), washer (6) and nut (5).
- (8) Place tip (2) on rudder (9) and secure with screws (1).
- (9) Install rudder per Removal/Installation, Paragraph 1 and Figure 401.

D. Rudder Trim Tab Adjustment

The rudder trim tab consists of a ground adjustable tab located on the lower end of the rudder trailing edge. This tab can be bent to provide rudder trim. Bend the tab opposite the direction of rudder correction desired.

NOTE: The aircraft can be rigged to suit individual requirements by adjusting the fixed trim tab on the rudder. Do not exceed 45° as it will not contribute any more toward trim.

2. Rudder Balancing

Refer to Section 27-1-1 for control surface balancing procedures.

**AA-5 SERIES
MAINTENANCE MANUAL**

MAINTENANCE PRACTICES - CLEANING/PAINTING

1. **Cleaning/Painting**

CAUTION: WHEN CONTROL SURFACES ARE PAINTED THEIR BALANCE IS CHANGED. ALWAYS CHECK BALANCE AFTER PAINTING.

Refer to Chapter 20 for proper cleaning and painting procedures.

ELEVATOR & TAB - DESCRIPTION/OPERATION

1. General (See Figure 1.)

A. Elevator Control System

As the control wheel is moved fore and aft, its displacement is transmitted by cables to the bellcrank on the elevator. Turnbuckles in the elevator control cables enable adjustment of cable tension, and control stops permit adjustment of elevator travel.

B. Elevator Assembly (See Figure 2.)

The elevator assembly consists of the elevator, and the anti-servo tab. The elevator is composed of a torque tube to which is bonded honeycomb ribs, which in turn are bonded to an aluminum skin. The one-piece skin is formed around the elevator leading edge, and bonded to the rear spar. The outboard end of the control surface is capped by a formed plastic tip attached with screws. Contained within the tip is the mass balance weight that provides proper control surface balance.

Attached to the inboard trailing edge of the elevator, is the anti-servo tab. This tab is attached to the elevator by a piano hinge. The tab is composed of a formed aluminum skin bonded to internal ribs, and actuated by an arm on its inboard end.

On Aircraft AA5-0001 through AA5-0199 the outboard end of the elevator, extending to the end of the horizontal stabilizer is covered by a plastic tip. The tab extends the full length of the elevator.

On Aircraft AA5-200 and subsequent, the area of the elevator from the end of the horizontal stabilizer to the outboard elevator rib is covered with aluminum panels. Outboard of the rib is covered by a plastic tip. The tab extends the full length of the elevator.

On AA-5A and AA-5B aircraft, the elevator is of similar construction except that it contains more ribs, and does not have as large an aerodynamic balance surface (overhang).

C. Elevator and Trim Linkage (See Figure 3.)

The elevator control cables are attached to the elevator bellcrank. This bellcrank moves the elevator in response to control column movement. The anti-servo bellcrank is mounted on bearings surrounding the elevator torque tubes. The trim arm, which is positioned by the trim system, establishes the position of the anti-servo bellcrank.

As the elevator is moved upward, a roller, attached to the anti-servo bellcrank, moves the front end of the trim tab arm downward. Since the trim tab arm is hinged at its center (in line with the trim tab hinge) the trim tab is forced upward by an amount proportional to elevator movement. When the elevator moves downward, movement of the trim tab is also in the downward direction.

Thus, the trim tab provides control pressure proper control "feel", and increases the effectiveness of the elevator.

Elevator trim is accomplished by positioning the anti-servo bellcrank, through the trim system such that the deflection of the trim tab is caused to increase in one direction while decreasing in the other direction.

D. Elevator Trim Control (See Figure 3.)

As the trim wheel is rotated, a set of spur gears turn the flexible shaft. This shaft is, in turn, connected through a universal joint to an aluminum shaft that extends to the empennage. The aluminum shaft drives a jackscrew that positions the anti-servo bellcrank.

AA-5 SERIES
MAINTENANCE MANUAL

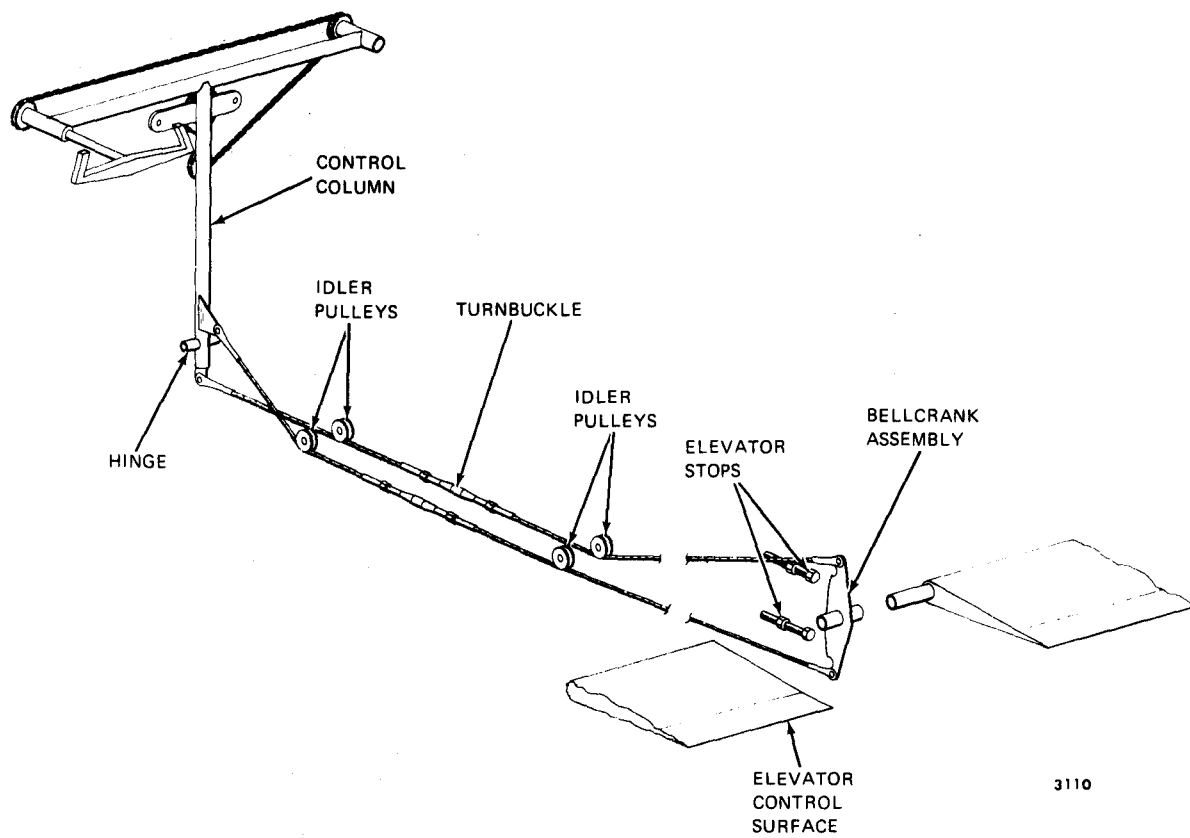

Elevator Control System
Figure 1

**AA-5 SERIES
MAINTENANCE MANUAL**

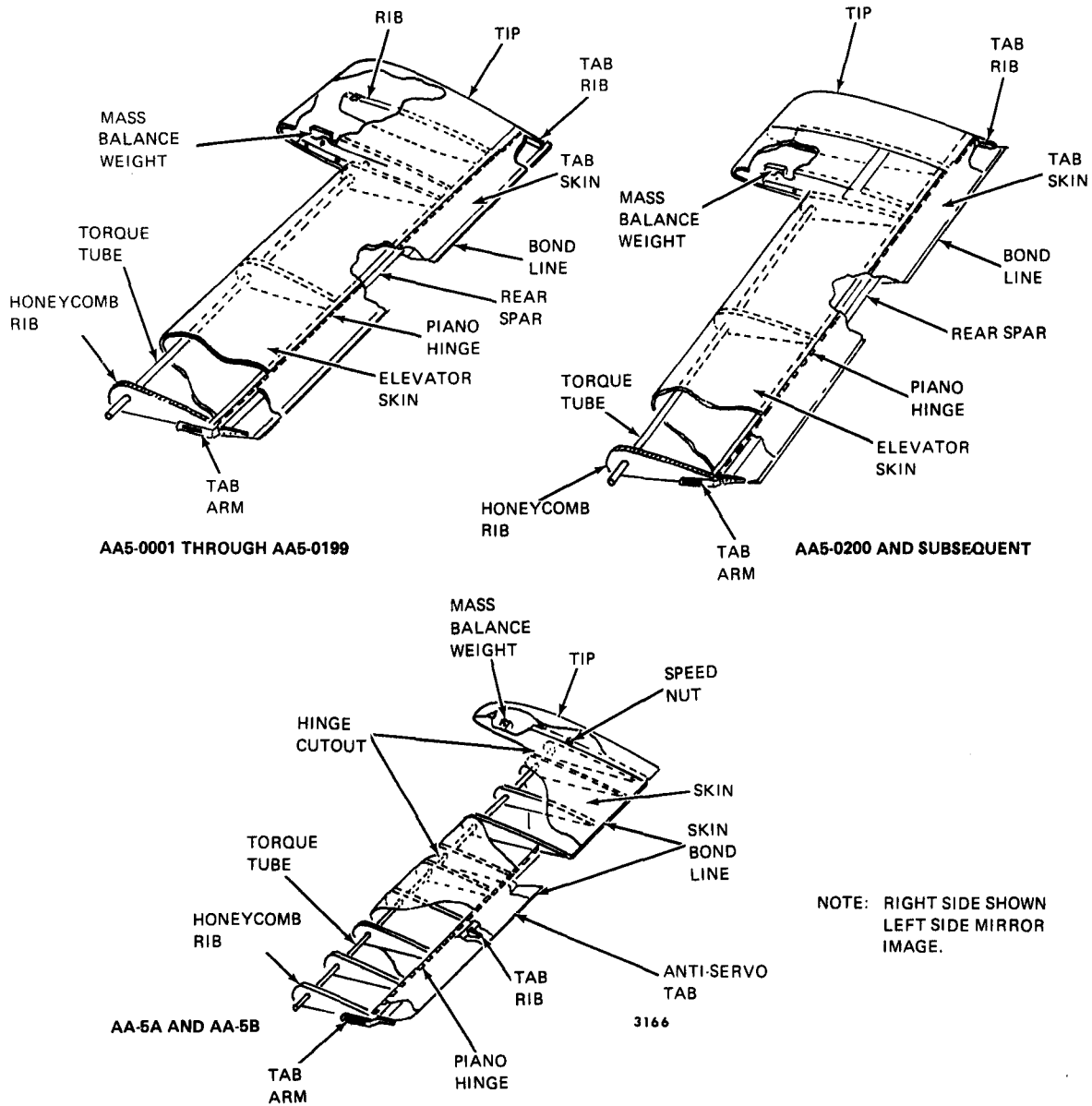

**Elevator Control Surface
Figure 2**

AA-5 SERIES
MAINTENANCE MANUAL

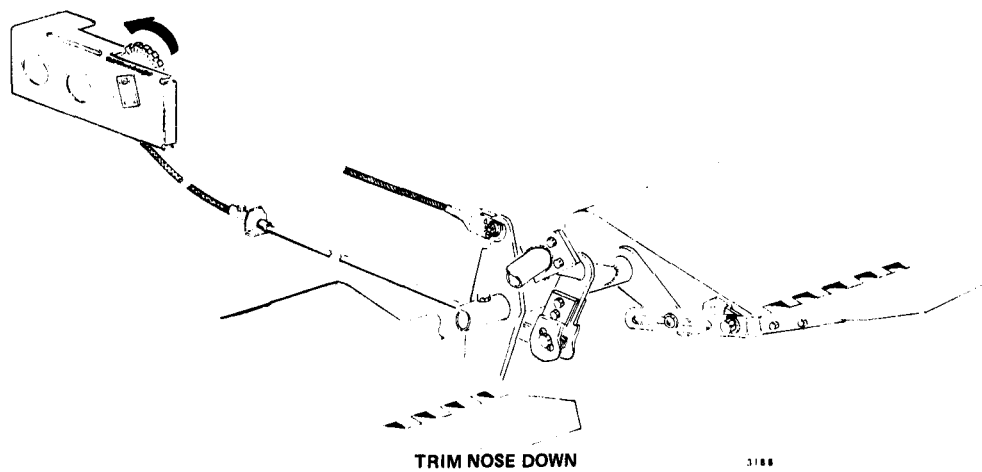
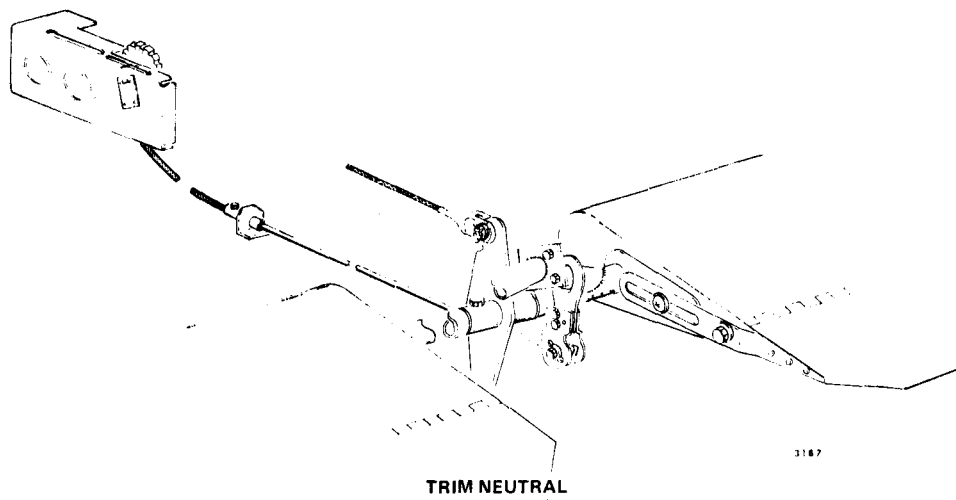
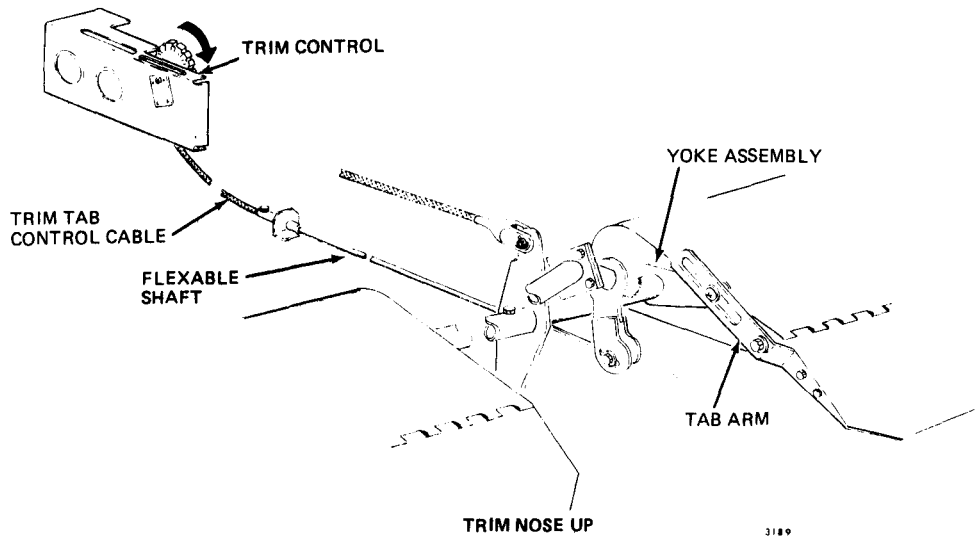

Elevator and Trim Linkage
Figure 3

MAINTENANCE PRACTICES – SERVICING

1. Lubrication

A. Trim Wheel Gear Lubrication

- (1) Remove console trim per Chapter 25.
- (2) Use a clean, lint-free cloth to wipe excess grease and foreign material from the gears.
- (3) Apply a coating of MIL-G-7711 (See Chapter 12.) grease to the gears.
- (4) Install console trim per Chapter 25.

B. Trim Actuator Shaft Lubrication

- (1) Remove tailcone per Chapter 53.
- (2) Use a clean, lint-free cloth to wipe excess grease and foreign material from the actuator shaft screw threads.
- (3) Apply a coating of MIL-G-7711 (See Chapter 12.) grease to the shaft screw threads.
- (4) Install tailcone per Chapter 53.

C. Trim Tab Bellcrank and Clevis Pin Lubrication.

- (1) Remove tailcone per Chapter 53.
- (2) Apply a light coating of oil, MIL-L-7870 (See Chapter 12.) to bellcranks at pivot points and to rollers. Also apply oil, MIL-L-7870 (See Chapter 12) to elevator bellcrank clevis pins.
- (3) Install tailcone per Chapter 53.

MAINTENANCE PRACTICES – REMOVAL/INSTALLATION

1. Elevator Removal/Installation

A. Elevator Removal (AA-5 Aircraft) (See Figure 401.)

- (1) Remove tailcone per Chapter 53.
- (2) Remove bolts (1) and washers (2) from trim tab arm (3).
- (3) Remove cotter pin (4), nut (5), washers (6) and bolt (7) from bracket (8).
- (4) Remove nut (9), washer (10) and bolt (11) from bellcrank (12).
- (5) Disconnect ground strap (13) from horizontal stabilizer (14).
- (6) Hold elevator (15) in the full up position, and remove the top screw (16) from hinge (17).
- (7) Hold elevator (15) in the full down position and remove screw (18).
- (8) Pull elevator (15) outboard and remove from aircraft.

B. Elevator Installation (AA-5 Aircraft) (See Figure 401.)

- (1) Position elevator so that its torque tube (19) aligns with bellcrank (12). Align holes in torque tube (19) and bellcrank (12), and install bolt (11), washer (10) and nut (9). Torque to standard value. (See Chapter 91.)
- (2) Hold elevator (15) in the full up position and align top mounting hole in hinge (17) with hole in horizontal stabilizer (14). Install screw (16).
- (3) Hold elevator (15) in full down position and install screw (18).
- (4) Attach ground strap (13) to horizontal stabilizer (14).
- (5) Align mounting holes in trim tab arm (3) with holes in trim tab (20) and install bolts (1) with washers (2). Torque to standard value. (See Chapter 91.)
- (6) Install bolt (7) and washers (6) through trim tab arm (3) and secure with nut (5) and cotter pin (4).
- (7) Rig elevator per Adjustment/Test, Paragraph 1.
- (8) Install tailcone per Chapter 53.

C. Elevator Removal (AA-5A and AA-5B Aircraft) (See Figure 402.)

- (1) Remove tailcone per Chapter 53.
- (2) Remove cotter pin (1), nut (2), washers (3), roller (4), bushing (5), washer (6), and bolt (7) from trim tab arm (8).
- (3) Cut safety wire (9) and remove bolt (10), washer (11) and spacer (12) from yoke assembly (13).
- (4) Remove nut (14), washers (15) and bolt (16).

NOTE: Support elevator so that it does not fall when the hinge bolts are removed.

- (5) At the two hinges, hold elevator in the full up position, and cut safety wire (17). Remove bolts (18), and washers (19 and 25).
- (6) Pull elevator (20) outboard until torque tube (21) clears bellcrank (22) and remove elevator from aircraft.

**AA-5 SERIES
MAINTENANCE MANUAL**

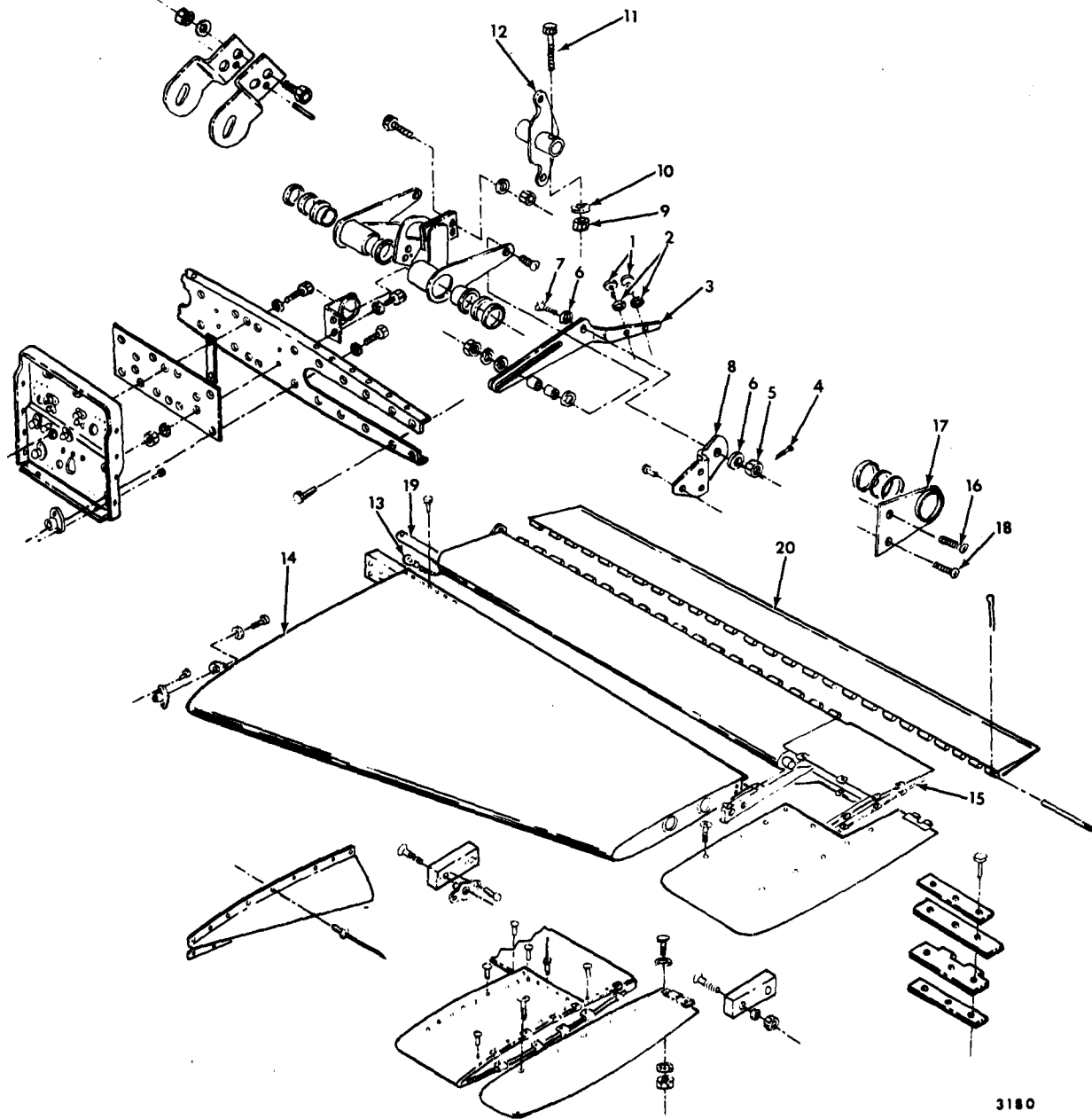

3180

- | | |
|-----------------|---------------------------|
| 1. Bolt | 11. Bolt |
| 2. Washer | 12. Bellcrank |
| 3. Trim Tab Arm | 13. Ground Strap |
| 4. Cotter Pin | 14. Horizontal Stabilizer |
| 5. Nut | 15. Elevator |
| 6. Washer | 16. Screw |
| 7. Bolt | 17. Hinge |
| 8. Bracket | 18. Screw |
| 9. Nut | 19. Torque Tube |
| 10. Washer | 20. Trim Tab |

**Elevator Removal/Installation (AA-5 Aircraft)
Figure 401**

**AA-5 SERIES
MAINTENANCE MANUAL**

D. Elevator Installation (AA-5A and AA-5B Aircraft) (See Figure 402.)

- (1) Position elevator (20) on horizontal stabilizer (23) so that hinges (24) align with bolt holes in stabilizer. Also ensure that torque tube (21) is inserted in bellcrank (22) with holes aligned.
- (2) Install bolts (18) and washers (19 and 25), through hinge (24) into nut plate in elevator.
- (3) Use bolt (16), washers (15), and nut (14) to secure bellcrank (22) to torque tube (21).
- (4) At the forward end of each elevator tip cap, check for a maximum 0.35-inch gap between the tip cap and the horizontal stabilizer. If the gap is excessive, adjust the quantity and position of washers (25, Figure 402) between the bellcranks (22) and at the hinges (24) as required to obtain the proper clearance. Tighten bolts (18 and 16) to standard value (Chapter 91). Secure bolts (18) with safety wire.
- (5) On bolt (7), place washer (6) and bushing (5).
- (6) Place roller (4) over bushing (5) and install bolt (7) through the slot in the trim tab arm (8).
- (7) Place washer (3) on bolt (7) and insert bolt (7) in rear arm of yoke assembly (13). Secure bolt (7) with washer (3), nut (2) and cotter pin (1).
- (8) Align forward arm of yoke (13) with hole in elevator (20).
- (9) Place bushing (12) in arm of yoke (13) and secure to elevator (20) with washer (11) and bolt (10). Torque to standard value and safety wire with 0.32 wire. (See Chapter 91.)
- (10) Rig elevator per Adjustment/Test, Paragraph 3.
- (11) Install tailcone per Chapter 53.

2. Elevator Disassembly/Assembly

A. Elevator Disassembly (AA-5 Aircraft) (See Figure 403.)

NOTE: Any disassembly or alteration of the elevator that affects its balance will require that the control surface be balanced prior to installation on aircraft.

(1) Trim Tab Removal

- (a) Remove cotter pin (1) from hinge (2).
- (b) Pull hinge pin (3) from hinge (2).
- (c) Disconnect ground strap (4) from elevator (5) and remove trim tab (6).

(2) Elevator Tip Removal (AA-5 Aircraft Prior to S/N 200)

NOTE: Since the outer hinge (7) is riveted to the elevator tip (8), it is necessary to remove the trim tab (6) prior to removing the tip.

- (a) Remove screws (9) from tip (8).
- (b) Pull tip (8) outboard to remove from elevator (5).

(3) Elevator Tip Removal (AA-5 Aircraft S/N 200 and Subsequent)

NOTE: It is not necessary to remove trim tab prior to removing elevator tip (10).

- (a) Remove nuts (11), washers (12), and screws (13) from hinge (14).
- (b) Remove screws (15) from elevator tip (10).
- (c) Pull elevator tip (10) outboard to remove from elevator (16).

**AA-5 SERIES
MAINTENANCE MANUAL**

- | | |
|-----------------|---------------------------|
| 1. Cotter Pin | 13. Yoke Assembly |
| 2. Nut | 14. Nut |
| 3. Washers | 15. Washer |
| 4. Roller | 16. Bolt |
| 5. Bushing | 17. Safety Wire |
| 6. Washer | 18. Bolt |
| 7. Bolt | 19. Washer |
| 8. Trim Tab Arm | 20. Elevator |
| 9. Safety Wire | 21. Torque Tube |
| 10. Bolt | 22. Bellcrank |
| 11. Washer | 23. Horizontal Stabilizer |
| 12. Spacer | 24. Hinge. |
| | 25. Thin Washers |

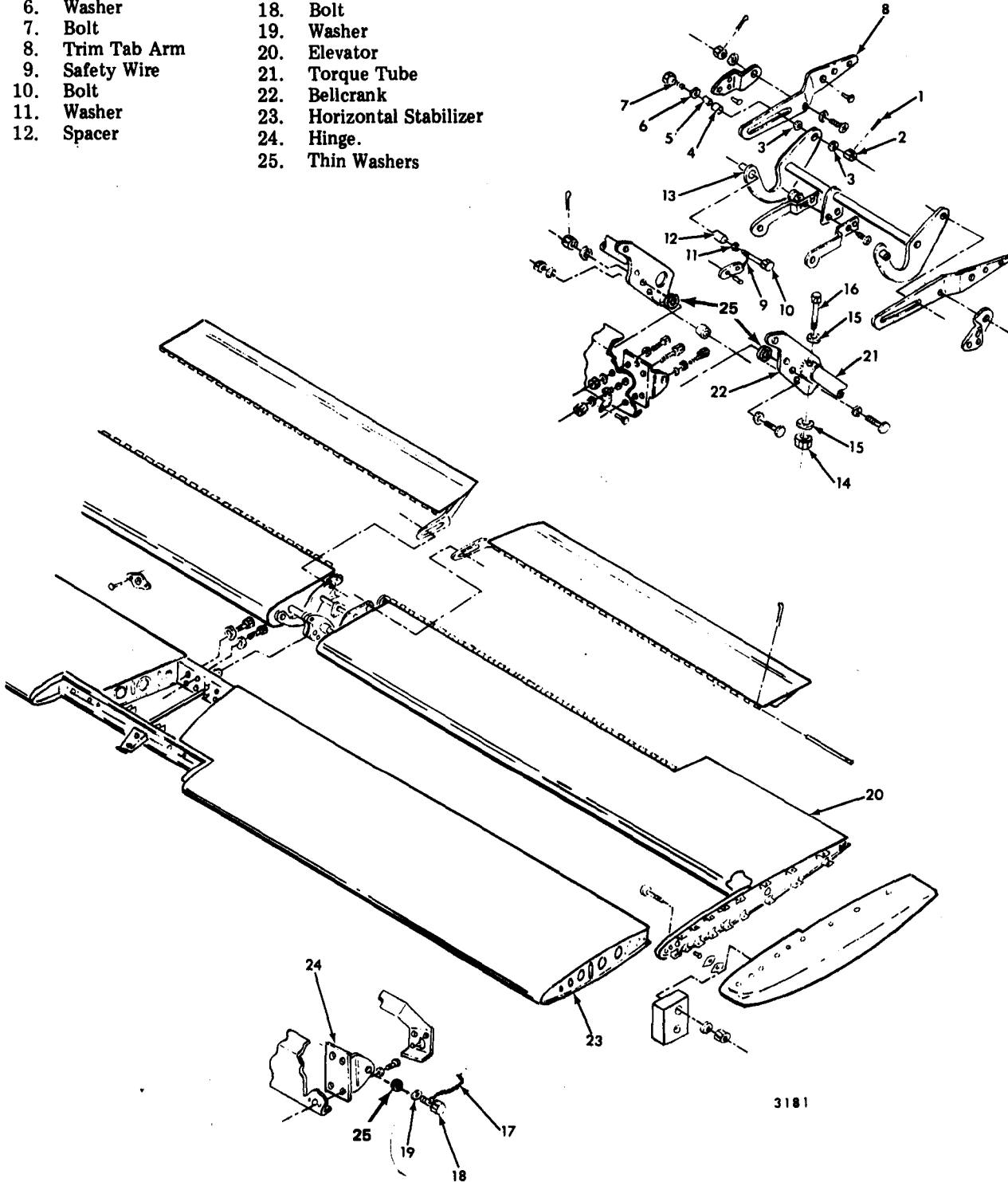

Elevator Removal/Installation (AA-5A and AA-5B Aircraft)
Figure 402

**AA-5 SERIES
MAINTENANCE MANUAL**

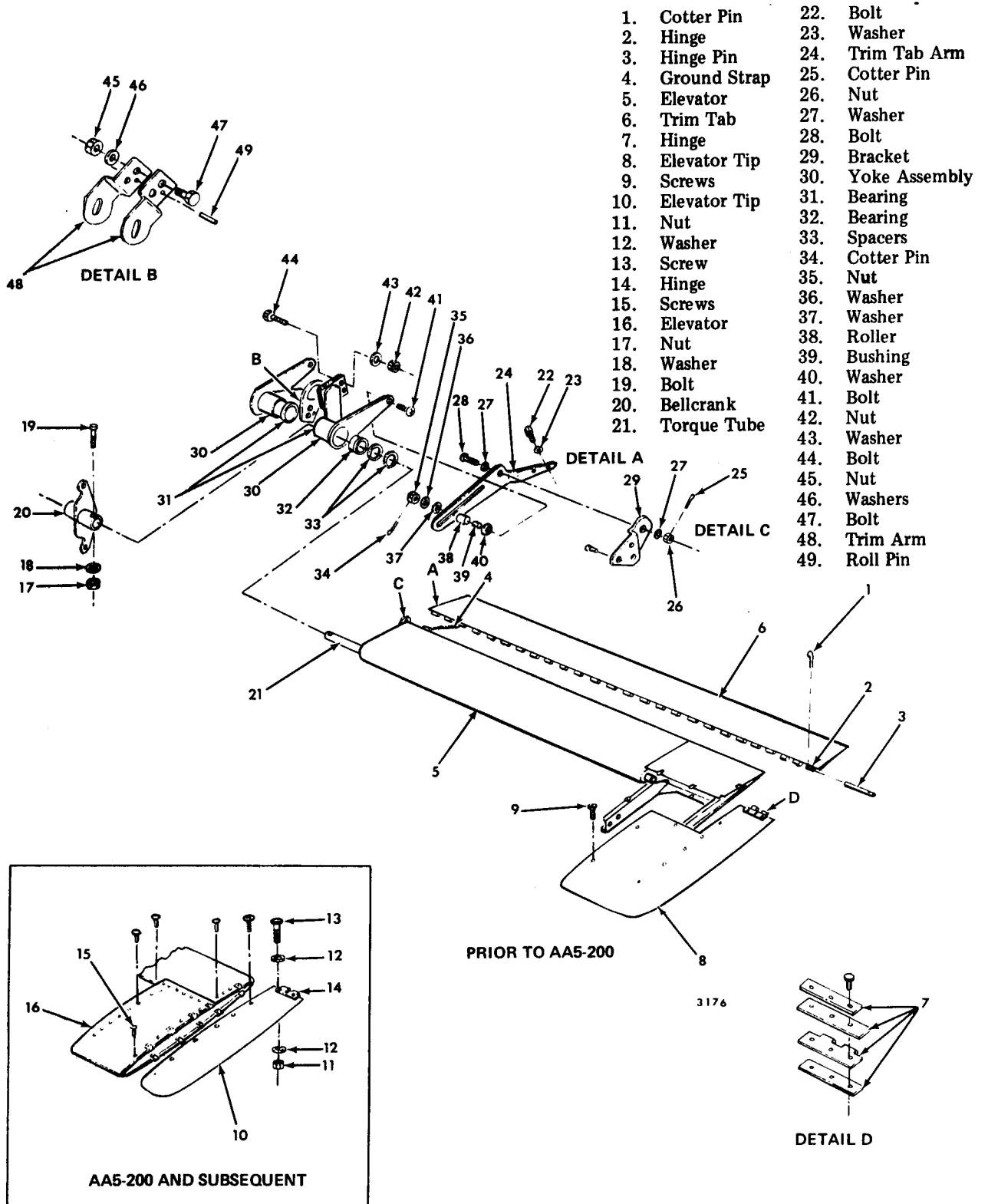

Elevator Disassembly/Assembly (AA-5 Aircraft)
Figure 403

**AA-5 SERIES
MAINTENANCE MANUAL**

(4) Elevator Linkage Disassembly (AA-5 Aircraft) (See Figure 403.)

- (a) Remove nut (17), washer (18), and bolt (19) from bellcrank (20).
- (b) Remove bolts (22) and washers (23) from trim tab arm (24).
- (c) Remove cotter pin (25), nut (26), washers (27), and bolt (28) from trim tab arm (24) and bracket (29).
- (d) Pull elevator torque tube (21) from bellcrank (20), and remove bearing (31).
- (e) Pull yoke assembly (30) from torque tube (21).
- (f) Remove bearing (32) and spacers (33) from torque tube (21).
- (g) Remove cotter pin (34), nut (35), washers (36 and 37), roller (38), bushing (39), washer (40), and bolt (41) from yoke assembly (30) and trim tab arm (24). Remove arm (24) from yoke assembly (30).
- (h) Remove nuts (42), washers (43), and bolts (44) from yoke assembly (30) and remove two halves of yoke assembly (30).
- (i) Remove nuts (45), washers (46), and bolts (47) from trim arm (48).
- (j) Drive roll pin (49) from arms (48) and remove them from right half of yoke assembly (30).

B. Elevator Assembly (AA-5 Aircraft) (See Figure 403.)

(1) Elevator Linkage Assembly

- (a) Position trim arms (24) on right yoke (30), and secure roll pin (49), bolts (47), washers (46), and nuts (45). Torque to standard value. (See Chapter 91.)
- (b) Assemble two halves of yoke assembly (30) and secure with bolts (44), washers (43), and nuts (42). Torque to standard value. (See Chapter 91.)
- (c) Place spacers (33) and bearing (32) on torque tube (21) in yoke assembly (30).
- (d) Install bearing (31) on torque tube (21), inside of yoke assembly (30).
- (e) Position bellcrank (20) so that it aligns with end of torque tube (21) and insert end of torque tube in bellcrank so that the holes align. Secure with bolt (19), washer (18), and nut (17). Torque to standard value. (See Chapter 91.)
- (f) Place bolt (41) through hole in yoke assembly arm (30).
- (g) On bolt (41) place washer (40) and bushing (39).
- (h) Place roller (38) over bushing (39).
- (i) Place slot in trim tab arm (24) over roller (38).
- (j) Place washers (37 and 36) on bolt (41) and secure with nut (35) and cotter pin (34).
- (k) Attach trim tab arm (24) to trim (6) with bolts (22) and washers (23). Torque to standard value. (See Chapter 91.)
- (l) Attach trim tab arm (24) to bracket (29) with bolt (28), washers (27), nut (26), and cotter pin (25).

**AA-5 SERIES
MAINTENANCE MANUAL**

- (2) Elevator Tip Installation (AA-5 Aircraft Prior to S/N 200)
 - (a) Position elevator tip (8) over elevator (5) so that holes align.
 - (b) Install screws (9).
- (3) Elevator Tip Installation (AA-5 Aircraft S/N 200 and Subsequent)
 - (a) Position elevator tip (10) so that holes in tip and hinge (14) align.
 - (b) Secure hinge (14) to tip (10) with screws (13), washers (12), and nuts (11).
 - (c) Position tip (10) to align its mounting holes with elevator (16) and secure tip with screws (15).
- (4) Trim Tab Installation
 - (a) Attach ground strap (4) to elevator (5).
 - (b) Align hinges (2) on trim tab (6) and elevator (5) and install hinge pin (3).
 - (c) Secure hinge pin (3) to hinge (2) with cotter pin (1).
- C. Elevator Disassembly (AA-5A and AA-5B Aircraft) (See Figure 404.)
 - (1) Trim Tab Removal
 - (a) Remove screws (1) and pull tip (2) from elevator (3).
 - (b) Remove cotter pin (4), nut (5), washers (6), roller (7), bushing (8), washer (9), and bolt (10) from trim tab arm (11).
 - (c) Remove cotter pin (12), nut (13), washers (14), and bolt (15) from trim tab arm (11) and bracket (16).
 - (d) Remove cotter pin (17) from hinge pin (18) and hinge (19).
 - (e) Pull hinge pin (18) from inboard end of hinge (19) and remove trim tab (20) from elevator (3).
 - (2) Linkage Disassembly
 - (a) Remove nut (21), washers (22), and bolt (23) from bellcrank (24).
 - (b) Cut safety wire (25). Remove bolt (26), washer (27), and bushing (28) from yoke assembly (29).
 - (c) Pull torque tube (30) from bellcrank (24).
 - (d) Remove cotter pin (31), nut (32), washers (33), and bolt (34) from bellcrank (24) and hinge (35).
 - (e) Remove nuts (36), washers (37), bolts (38), and spacers (39) from bellcrank (24) and separate two halves of bellcrank.
 - (f) Remove nuts (40), washers (41), and bolts (42) and remove tab arms (43) from yoke assembly (29).

AA-5 SERIES
MAINTENANCE MANUAL

1. Screws
2. Elevator Tip
3. Elevator
4. Cotter Pin
5. Nut
6. Washers
7. Roller
8. Bushing
9. Washer
10. Bolt
11. Trim Tab Arm
12. Cotter Pin
13. Nut
14. Washers
15. Bolt
16. Bracket
17. Cotter Pin
18. Hinge Pin
19. Hinge
20. Trim Tab
21. Nut
22. Washers
23. Bolt
24. Bellcrank
25. Safety Wire
26. Bolt
27. Washer
28. Bushing
29. Yoke Assembly
30. Torque Tube
31. Cotter Pin
32. Nut
33. Washers
34. Bolt
35. Hinge
36. Nuts
37. Washers
38. Bolts
39. Spacers
40. Nuts
41. Washers
42. Bolts
43. Trim Tab Arm

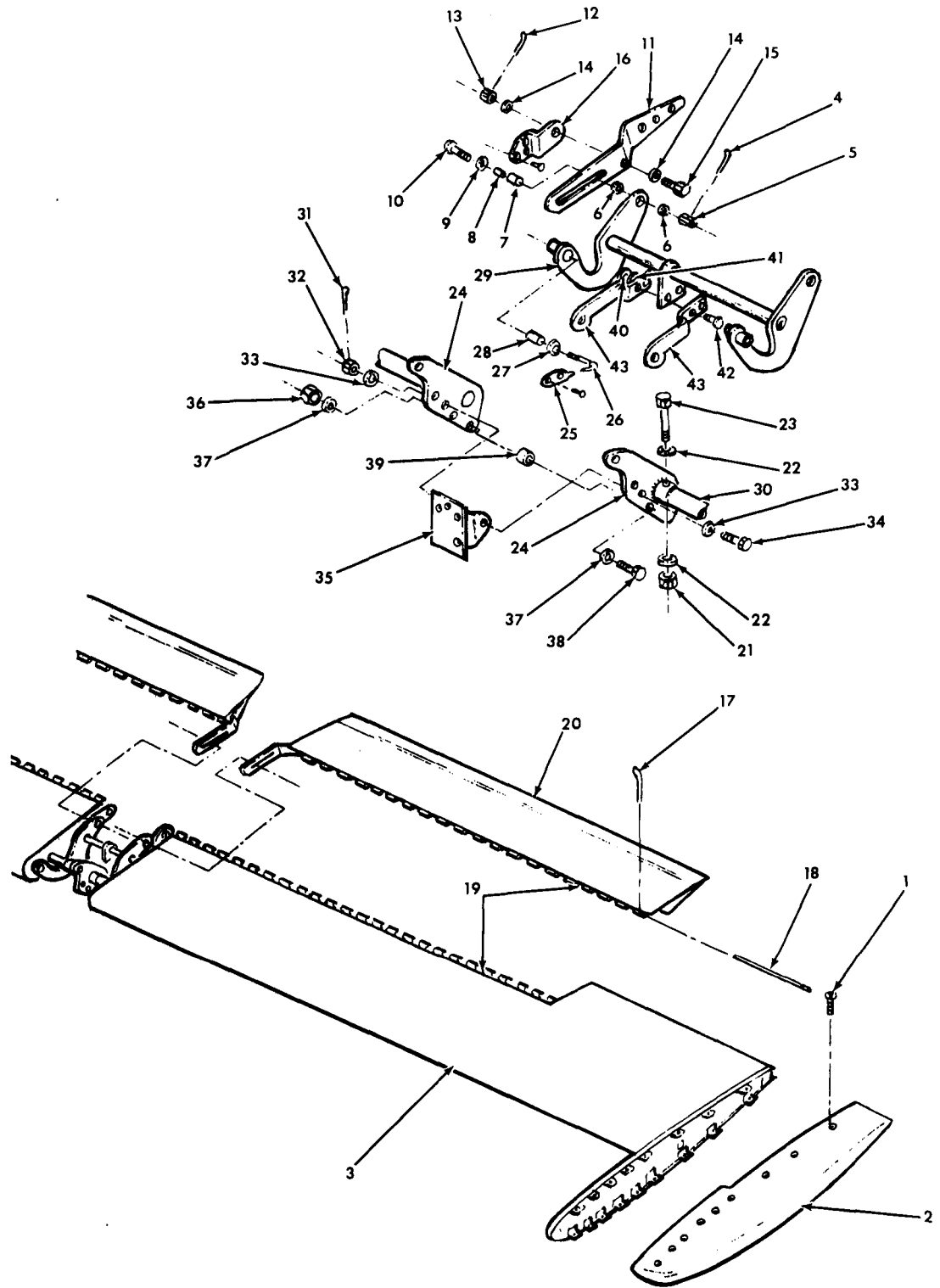

Elevator Disassembly/Assembly (AA-5A and AA-5B Aircraft)
Figure 404

D. Elevator Assembly (AA-5A and AA-5B Aircraft) (See Figure 404.)

(1) Trim Tab Installation

- (a) Position tip (2) on end of elevator (3) so that holes align. Secure with screws (1).
- (b) Position trim tab so that its hinge (19) aligns with that of the elevator.
- (c) Drive hinge pin (18) through hinge from inboard end.
- (d) Align hole in end of hinge pin with that in hinge and secure pins (18) with cotter pin (17).

(2) Linkage Assembly

- (a) Position spacers (39) between halves of bellcrank (24). Align holes and secure with bolts (38), washers (37) and nuts (36).
- (b) Insert hinge (35) between halves of bellcrank (24) and align holes. Secure with bolt (34), washers (33), nut (32), and cotter pin (31).
- (c) Insert torque tube (30) in bellcrank (24), align holes, and secure with bolt (23), washers (22) and nut (21). Torque to standard value. (See Chapter 91.)
- (d) Position tab arms (43) on yoke assembly (29) and secure with bolts (42), washers (41) and nuts (40). Torque to standard value. (See Chapter 91.)
- (e) Place washer (27) and spacer (28) on bolt (26).
- (f) Align hole in front arm of yoke assembly (29) with mounting hole in elevator (3) forward of torque tube (30).
- (g) Insert bolt (26) with bushing (28) and washer (27) through yoke assembly (29) arm into elevator, and torque to standard value. (See Chapter 91.) Safety wire bolt (26), with .032 wire.
- (h) On bolt (10) place washer (9) and bushing (8).
- (i) Place roller (7) over bushing (8) and install bolt with bushing and roller in slot in trim tab arm (11).
- (j) Place washer (6) on bolt (10) and insert bolt (10) through hole in rear arm of yoke assembly (29).
- (k) Secure bolt (10) with washer (6), nut (5) and cotter pin (4).
- (l) Place washer (14) on bolt (15) and insert bolt (15) through hole in trim tab arm (11) and hole in bracket (16).
- (m) Secure with washer (14), nut (13) and cotter pin (12).

3. Trim Tab Control Removal/Installation

A. Trim Tab Control Removal (See Figure 405.)

(1) Actuator Removal

- (a) Remove tailcone per Chapter 53.
- (b) Remove nuts (1), washers (2), bolts (3) and drive pin (4) from trim arms (5).
- (c) Remove ELT access panel per Chapter 53.
- (d) Remove nut (6), washer (7) and bolt (8) from torque tube (9).

**AA-5 SERIES
MAINTENANCE MANUAL**

- (e) Pull actuator (10) aft until it clears guide assembly (11).
- (f) Remove bearings (12) and washer (13).
- (g) Remove nuts (14), washers (15) and bolts (16), then remove guide assembly.

(2) Torque Tube Removal

- (a) Remove console trim per Chapter 25.
- (b) Remove roll pins (17) from universal (18) and pull rear torque tube (9) from universal (18).
- (c) Pull rear torque tube (9) forward through its bushing (19) until it clears the rear support (20).
- (d) Pull universal (18) from front torque tube (21).
- (e) Remove nut (22), washer (23) and bolt (24) from flexible cable (25), and pull cable (25) from torque tube (21).
- (f) Pull torque tube (21) aft until it clears bushing (26) in front support (27) and bushing (28) in aft support (29).

(3) Trim Wheel Assembly Removal

- (a) Remove console trim per Chapter 25.
- (b) Drive roll pin (30) from pinion gear (31), and pull flexible shaft (25) from bracket assembly (33).
- (c) Drive roll pin (34) from flexible shaft (25) and pull shaft (32) from flexible shaft (25).
- (d) Remove cotter pin (35), nut (36), washers (37 and 38) and bolt (39) from trim wheel (40).
- (e) Drive roll pin (41) from trim wheel (40) and remove pinion gear (42).
- (f) Remove cotter pin (43), nut (44), washers (45 and 46), bolt (47) and indicator bracket (48) from bracket assembly (33).

(4) Actuator Disassembly

- (a) Remove nuts (49) and washers (50). Pull trim arms (5) from actuator assembly (51).
- (b) Remove roller (52), bushing (53) and washer (54) from actuator assembly (51).
- (c) Unscrew actuator assembly (51) from screw (10).

B. Trim Tab Control Installation (See Figure 405.)

(1) Actuator Assembly/Installation

- (a) Screw actuator (51) onto screw (10).
- (b) Place washers (54) and bushings (53) on actuator (51).
- (c) Place rollers (52) over bushings (53) and place trim arms (5) over rollers (52). Secure with washers (50) and nuts (49). Torque to standard value. (See Chapter 91.)
- (d) Place arms (5) on yoke assembly and secure with roll pin (4), bolts (3), washers (2) and nuts (1). Torque to standard value. (See Chapter 91.)

**AA-5 SERIES
MAINTENANCE MANUAL**

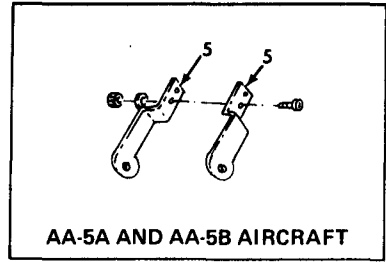
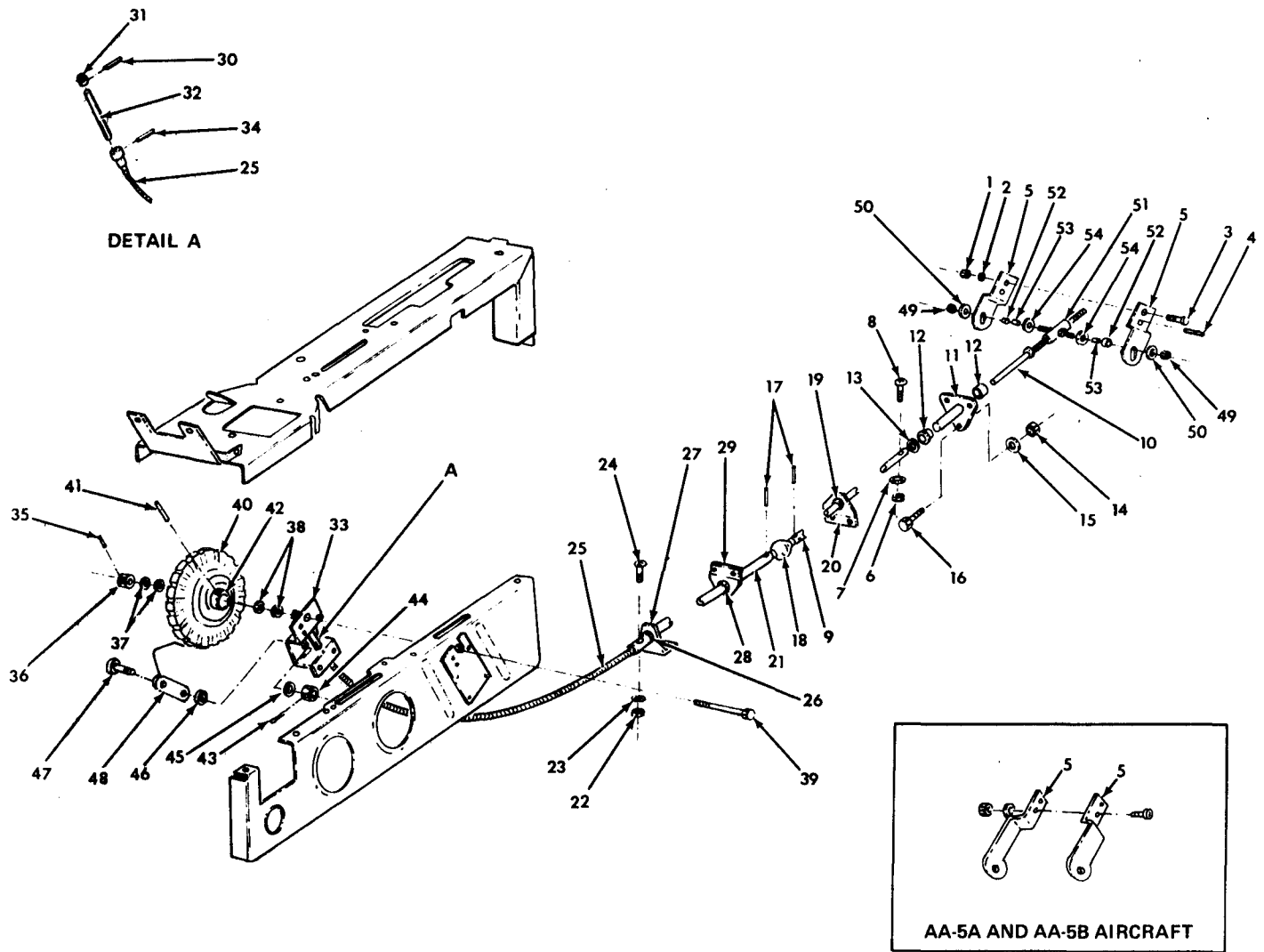

3175

- | | | |
|----------------|----------------------|-----------------------|
| 1. Nut | 20. Rear Support | 39. Bolt |
| 2. Washer | 21. Torque Tube | 40. Trim Wheel |
| 3. Bolt | 22. Nut | 41. Roll Pin |
| 4. Drive Pin | 23. Washer | 42. Pinion Gear |
| 5. Trim Arms | 24. Bolt | 43. Cotter Pin |
| 6. Nut | 25. Flexible Cable | 44. Nut |
| 7. Washer | 26. Bushing | 45. Washer |
| 8. Bolt | 27. Support | 46. Washer |
| 9. Torque Tube | 28. Bushing | 47. Bolt |
| 10. Actuator | 29. Support | 48. Indicator Bracket |
| 11. Guide | 30. Roll Pin | 49. Nut |
| 12. Bearing | 31. Pinion Gear | 50. Washer |
| 13. Washer | 32. Shaft | 51. Actuator Assembly |
| 14. Nut | 33. Bracket Assembly | 52. Roller |
| 15. Washer | 34. Roll Pin | 53. Bushing |
| 16. Bolt | 35. Cotter Pin | 54. Washers |
| 17. Roll Pin | 36. Nut | |
| 18. Universal | 37. Washer | |
| 19. Bushing | 38. Washer | |

Trim Tab Control Removal/Installation
Figure 405

(2) Trim Wheel Assembly

- (a) Insert shaft (32) into flexible shaft (25) and secure with roll pin (34).
- (b) Insert shaft (32) through Nyliner bushings in bracket assembly (33).
- (c) Place pinion gear (31) on shaft (32) and secure with roll pin (30).
- (d) Place pinion (42) in trim wheel (40); align holes, and secure with roll pin (41).
- (e) Place bolt (47) through trim indicator (48), washer (46) and bracket assembly (33).
- (f) Secure with washer (45), nut (44) and cotter pin (43).
- (g) Place bolt (39) through bracket assembly (33), and place washers (38) on bolt (39).
- (h) Slide trim wheel (40) on bolt (39) until pinion teeth (31 and 42) engage, and follower pin on trim indicator (48) engages in spiral groove on trim wheel (40).
- (i) Secure trim wheel (40) with washers (37), nut (36) and cotter pin (35).

(3) Torque Tube Installation

- (a) Slide forward torque tube (21) through its rear support (29) and then through its forward support (27).
- (b) Place end of flexible shaft (25) in front end of forward torque tube (21) and align holes. Secure with screw (24), washer (23) and nut (22).
- (c) Place one end of universal (18) in rear end of torque tube (21). Secure with roll pin (17) and safety wire pin with 0.032 wire.
- (d) Slide aft torque tube (9) through lower elevator cable access hole and through the torque tube support (20).
- (e) Place forward end of rear torque tube (9) over the universal end (18). Align holes, and secure with roll pin (17). Safety wire roll pin (17) with 0.032 wire.
- (f) Place bushings (12) in guide assembly (11), and secure guide assembly (11) to fuselage with bolts (16), washers (15) and nuts (14). Torque to standard value. (See Chapter 91.)
- (g) Slide screw (10) through guide assembly (11) and place washer (13) on end of screw (10).
- (h) Insert front end of screw (10) in aft end of torque tube (9). Align holes and secure with screw (8), washer (7) and nut (6).

4. Elevator Bearing Removal/Installation

- A. Remove the elevator as described in Paragraph 1 or 3 above.
- B. The elevator bearings are located in the elevator hinges at the aft fuselage bulkhead and at the outboard end of each horizontal stabilizer. The bearings are removed and installed in the same manner as the aileron bearings. (Refer to Section 27-1-1.)

5. Elevator Bearing Wear Limits

Refer to Section 27-1-1, paragraph entitled "Aileron Bearing Wear Limits."

6. Elevator Trim Tab Free Play Reduction
(AA-5A and AA-5B)

A. Free Play

Free play is defined as the accumulated free motion at the elevator trim tab trailing edge, the sum of normal manufacturing tolerances, wear, and any other contributing conditions. When progressed sufficiently to allow an excessive amount of free play, replacement of defective components is indicated. While any component in the elevator trim tab system linkage may be involved, data obtained inspecting and repairing high-time, in-service aircraft indicate that the components listed below frequently contribute to excessive free play.

- (1) Trim tab arms (11, Figure 404) rollers (7), and bushings (8). Refer to Subparagraph B below.
- (2) Excessive end play at actuator assembly (51, Figure 405). Refer to Subparagraph C below.
- (3) Trim arms (5, Figure 405), rollers (52), and bushings (53). Refer to Subparagraph D below.

B. Trim Tab Arm and Roller Replacement (AA-5A and AA-5B Aircraft)

- (1) Remove the elevator and disassemble as required to remove the trim tab. Refer to Paragraphs 1 and 2 above.

CAUTION: TO AVOID MISALIGNMENT OR OTHER DAMAGE TO THE TRIM TAB, FOLLOW THE INSTRUCTIONS GIVEN BELOW CLOSELY. DO NOT ATTEMPT TO DRILL THE RIVETS OUT.

- (2) At the inboard end of the elevator trim tab, locate the rivets securing the trim tab arm (11, Figure 404) to the trim tab. Block all openings into the trim tab interior with masking tape to prevent the entry of foreign matter.
- (3) Grind off the heads of the three rivets securing the trim tab arm to the trim tab. Use a soft brush to remove all grindings and other foreign matter from the end of the trim tab.
- (4) Remove the tape from the openings. Using a drift or punch, lightly drive the rivets into the interior of the trim tab.

NOTE: It is essential that all rivet parts be removed from the trim tab interior. Foreign material left within the trim tab could cause surface balance change, corrosion, or block the drain holes.

- (5) Rotate the trim tab so that it is standing on the hinge. Using a pipe cleaner, wire, or other means, locate and move the rivet parts out through the gap between the inboard rib and the skin at the leading edge.
- (6) Temporarily install the trim tab and the hinge pin. Open the pilot holes in the new trim tab arm to 0.143/0.146 inch. Using alignment clamps (Cleco or equivalent), install the new trim tab arm in its proper position.
- (7) Use the existing hole in the bracket (16, Figure 404) and/or the elevator trim tab hinge pin to locate and drill a 0.187/0.190-inch hole in the trim tab arm concentric with the hinge pin center line.
- (8) Remove the alignment clamps and install the trim tab arm to the trim tab using blind rivets. Part Number CR3243-4-3 or CR2249-4-3 rivets may be used.

NOTE: Lubricate all moving parts during assembly in accordance with servicing instructions (Chapter 12).

- (9) Using a new bushing and roller (8 and 7, Figure 404), assemble and install the elevator in accordance with instructions contained in Paragraphs 1 and 2 above.
- (10) Perform an elevator and elevator trim tab rigging check. Refer to Adjustment/Test, Paragraph 1, this section, for rigging procedures.

**AA-5 SERIES
MAINTENANCE MANUAL**

C. Actuator Assembly End Play Reduction

With the cone removed, actuator assembly end play can be measured at the aft bearing (12, Figure 405) as follows:

- (1) With approximately 10 pounds of hand pressure, rock the actuator assembly (51, Figure 405) fore and aft along its longitudinal axis several times.
- (2) While maintaining the actuator assembly in the aft position measure the gap between the aft bearing (12) and the actuator (10). Maximum permissible gap is 0.010 inch.
- (3) Add Part Number 607016-1 shims at the washer (13) as required to provide a maximum end play of 0.010 inch.

D. Trim Arm and Roller Replacement

Wear at the trim arm slot and roller can result in free play at the elevator trim tab trailing edge. Replace both trim arms (5, Figure 405), rollers (52) and bushings (53). Inspect the arms of the actuator assembly (51) for scoring and replace if defective.

7. Elevator Bellcrank and Torque Tube Repair

Excessive play in the elevator control system can be caused by slippage at the elevator bellcrank and elevator torque tube. In certain high-time, in-service aircraft, this condition has been traced to the enlargement or elongation of the attach holes in the elevator torque tube (5, Figure 406), at the elevator bellcrank (4).

The following is an acceptable repair from a structural standpoint:

- A. Remove the tailcone assembly in accordance with Chapter 53.
- B. Hold the elevator bellcrank (4, Figure 406) firmly against one of the elevator control stops (7). Grasp one elevator (6) at the trailing edge and attempt to rotate the elevator torque tube (5) in both directions. Repeat this procedure on the opposite elevator. (The torque tube is an integral part of the elevator.)
- C. If play is noted, determine the largest diameter of the elevator torque tube and elevator bellcrank bolt holes.
- D. If the largest diameter exceeds 0.2505 inch, open the existing bolt holes in the elevator torque tube and elevator bellcrank to 0.312 to 0.315 inch diameter.

NOTE: Do not increase the hole size beyond that specified. If the holes will not clean up, the elevator and elevator bellcrank must be replaced. If removal for repair/replacement is necessary, refer to Maintenance Practices - Removal Installation, Paragraphs 1, 2 and 3, this section.

- E. If existing bolt holes are opened in accordance with sub-paragraph D above, install oversize attach hardware listed below.

| | |
|-------------|---------|
| NAS464P5A19 | Bolt |
| AN960-516 | Washers |
| MS20364-524 | Nut |

- F. If repair or replacement is made, perform elevator rigging check. Refer to Adjustment/Test, Paragraph 1, this section, for rigging procedures.
- G. Record the repair/replacement in the aircraft log.

AA-5 SERIES
MAINTENANCE MANUAL

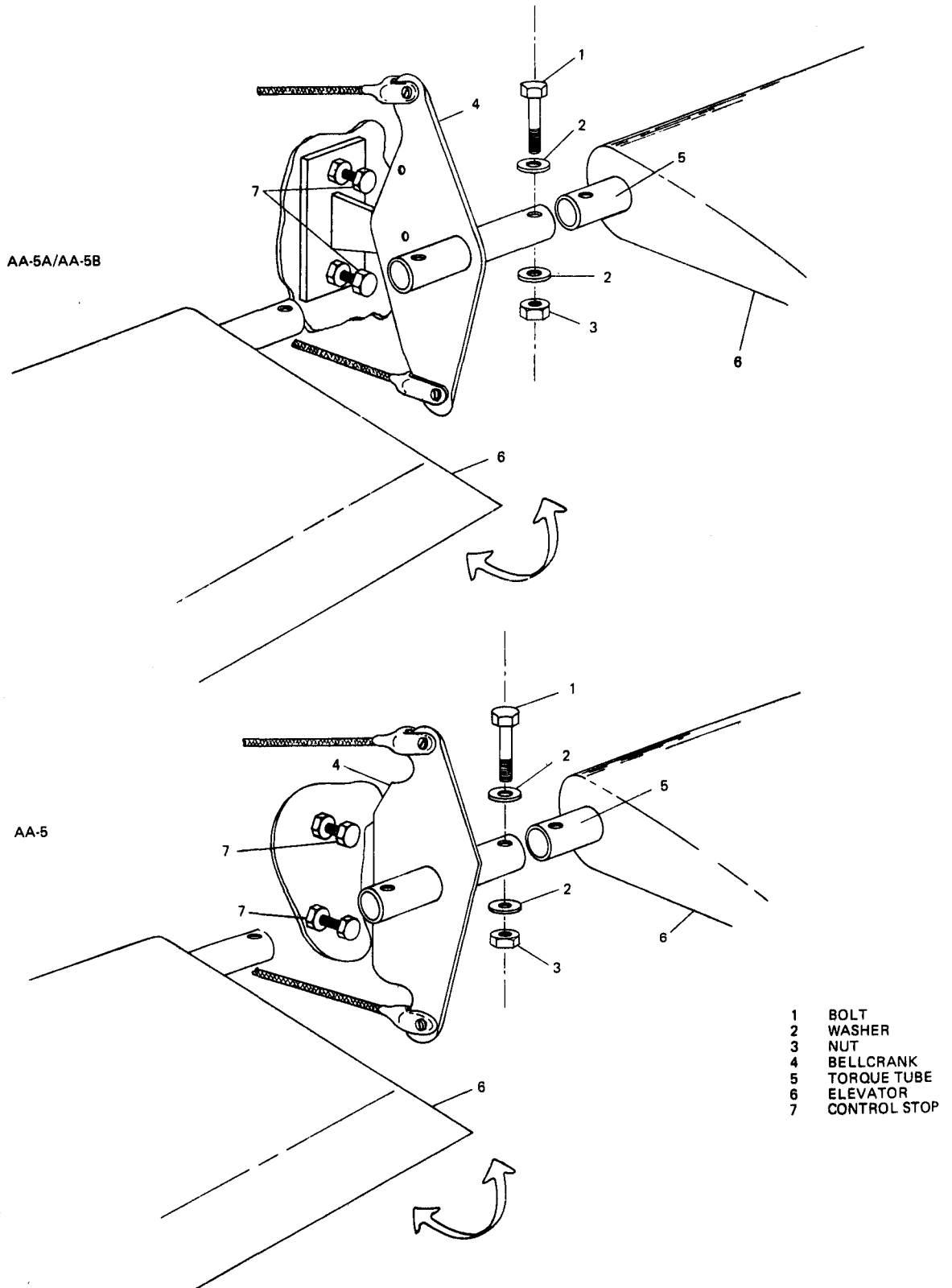

Elevator Bellcrank and Torque Tube Repair
Figure 406

MAINTENANCE PRACTICES — ADJUSTMENT/TEST

1. Rigging

A. Elevator Rigging (AA-5 Aircraft)

- (1) Secure the control wheel in the neutral position by installing the control wheel lock in the forward control wheel hole on aircraft with two holes in this shaft. On aircraft with only one hole in the control wheel shaft, a fixture (Part No. DE 5005-501, Figure 501), must be used for this purpose.
- (2) Remove trim per Chapter 25 to provide access to the elevator turnbuckles located under the aft end of the console.
- (3) Adjust the elevator turnbuckles (Figure 502) until the elevator is located at neutral. Neutral position of the elevators is the position where elevators are streamlined with the stabilizer.
- (4) Check the elevator cable tension and adjust the turnbuckles to obtain $35 \pm 0, -5$ lbs tension. (At the average temperature for the aircraft operation area.) Recheck the 0° position of the elevator surface.
- (5) Remove control wheel lock (or rigging fixture).
- (6) Remove tailcone per Chapter 53.
- (7) Loosen lock nuts (Figure 503) on elevator control stops.
- (8) Place an angle vernier scale (or inclinometer) on the elevator surface forward of the trim tab, and in the center of the elevator.
- (9) Hold the elevator at neutral (elevator streamlined with horizontal stabilizer) and center the bubble in the angle vernier scale. Lock the zero adjustment.
- (10) Move the elevator to its full up position (against the control stop) and measure the throw of the control on the angle vernier scale.
- (11) Adjust the top elevator stop to obtain $30^\circ \pm 2^\circ$ indication on the angle vernier scale. Tighten control stop lock nut.
- (12) Move the elevator to its full down position (against the control stop) and measure the throw of the control on the angle vernier scale.
- (13) Adjust the bottom elevator stop to obtain $20^\circ \pm 2^\circ$ indication on the angle vernier scale. Tighten control stop lock nut.
- (14) Recheck cable tension, and safety turnbuckles with clips.
- (15) Replace trim per Chapter 25.
- (16) Reinstall tailcone per Chapter 53.

B. Elevator Rigging (AA-5A Aircraft)

- (1) Secure the control wheel in the neutral position by installing fixture (Part No. DE 5005-501, Figure 501).
- (2) Remove trim per Chapter 25 to provide access to the elevator turnbuckles located under the aft end of the console.
- (3) Adjust the elevator turnbuckles (Figure 502) until the elevator is located at neutral. Neutral position of the elevators is the position where elevators are streamlined with the stabilizer.

AA-5 SERIES
MAINTENANCE MANUAL

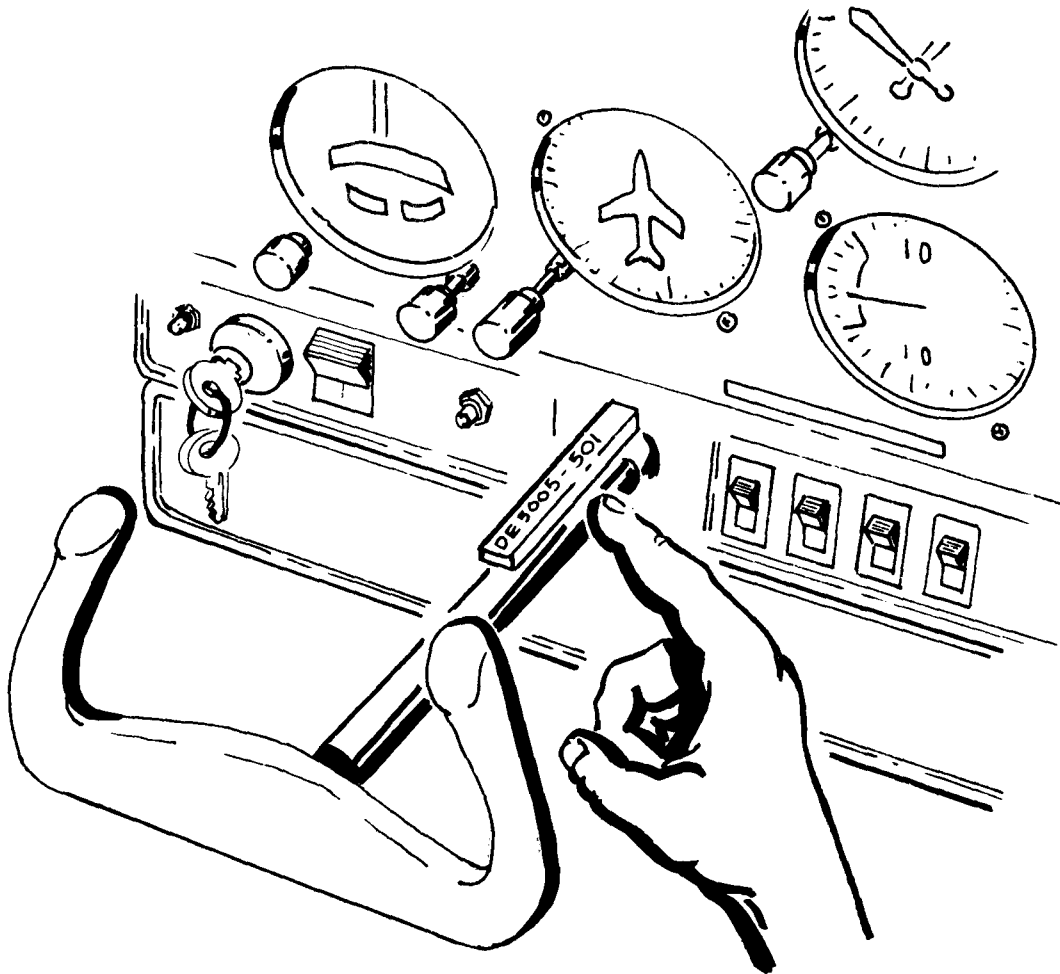

Elevator Rigging Fixture
Figure 501

AA-5 SERIES
MAINTENANCE MANUAL

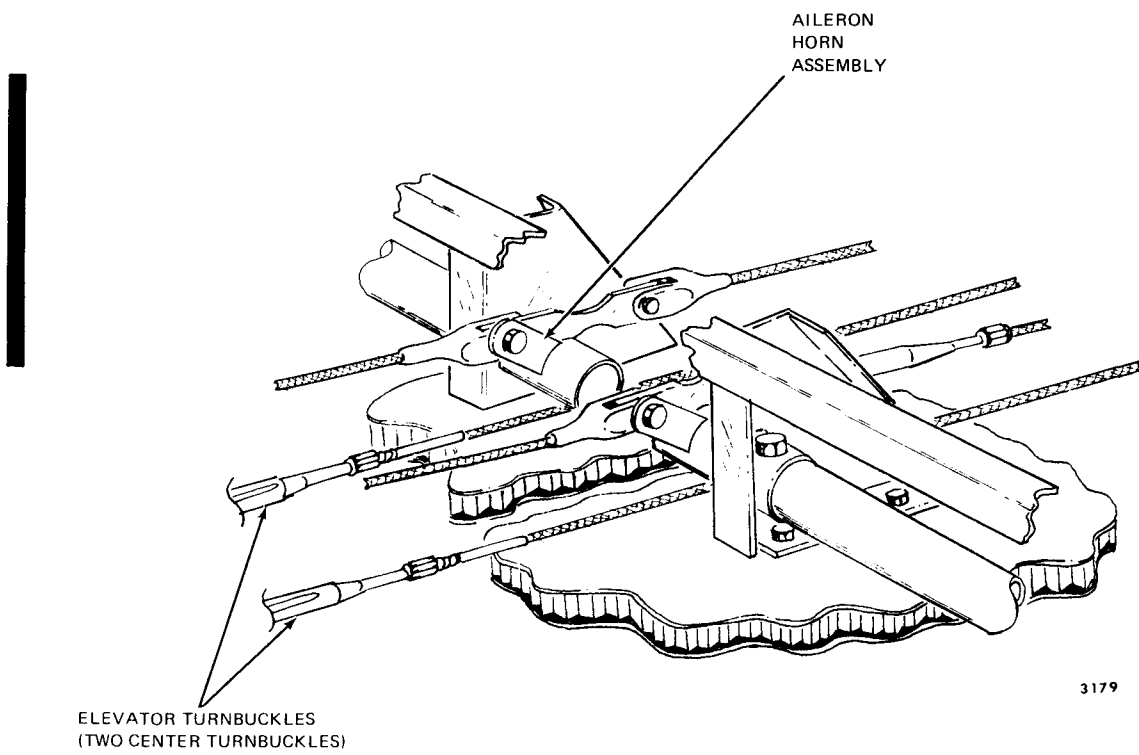

Elevator Turnbuckles
Figure 502

AA-5 SERIES
MAINTENANCE MANUAL

- (4) Check the elevator cable tension and adjust the turnbuckles to obtain $35 + 0, -5$ pounds tension. (At the average temperature for the aircraft operation area). Recheck the 0° position of the elevator surface.
- (5) Remove rigging fixture.
- (6) Remove tailcone per Chapter 53.
- (7) Loosen lock nuts (Figure 503) on elevator control stops.
- (8) Place an angle vernier scale (or inclinometer) on the elevator surface forward of the trim tab, and in the center of the elevator.
- (9) Hold the elevator at neutral (elevator streamlined with horizontal stabilizer) and center the bubble in the angle vernier scale. (Lock the zero adjustment.
- (10) Move the elevator to its full up position (against the control stop) and measure the throw of the control on the angle vernier scale.
- (11) Adjust the top elevator stop to obtain $23^\circ \pm 1^\circ$ indication on the angle vernier scale. Tighten control stop lock nut.
- (12) Move the elevator to its full down position (against the control stop) and measure the throw of the control on the angle vernier scale.
- (13) Adjust the bottom elevator stop to obtain $17^\circ \pm 2^\circ$ indication on the angle vernier scale. Tighten control stop lock nut.
- (14) Recheck cable tension, and safety turnbuckles with clips.
- (15) Replace trim per Chapter 25.
- (16) Reinstall tailcone per Chapter 53.

C. Elevator Rigging (AA-5B Aircraft)

- (1) Secure the control wheel in the neutral position by installing fixture (Part No. DE 5005-501, Figure 501).
- (2) Remove trim per Chapter 25 to provide access to the elevator turnbuckles located under the aft end of the console.
- (3) Adjust the elevator turnbuckles (Figure 502) until the elevator is located at neutral. Neutral position of the elevators is the position where elevators are streamlined with the stabilizer.
- (4) Check the elevator cable tension and adjust the turnbuckles to obtain $35 + 0, -5$ pounds tension. (At the average temperature for the aircraft operation area.) Recheck the 0° position of the elevator surface.
- (5) Remove rigging fixture.
- (6) Remove tailcone per Chapter 53.
- (7) Loosen lock nuts (Figure 503) on elevator control stops.

AA-5 SERIES
MAINTENANCE MANUAL

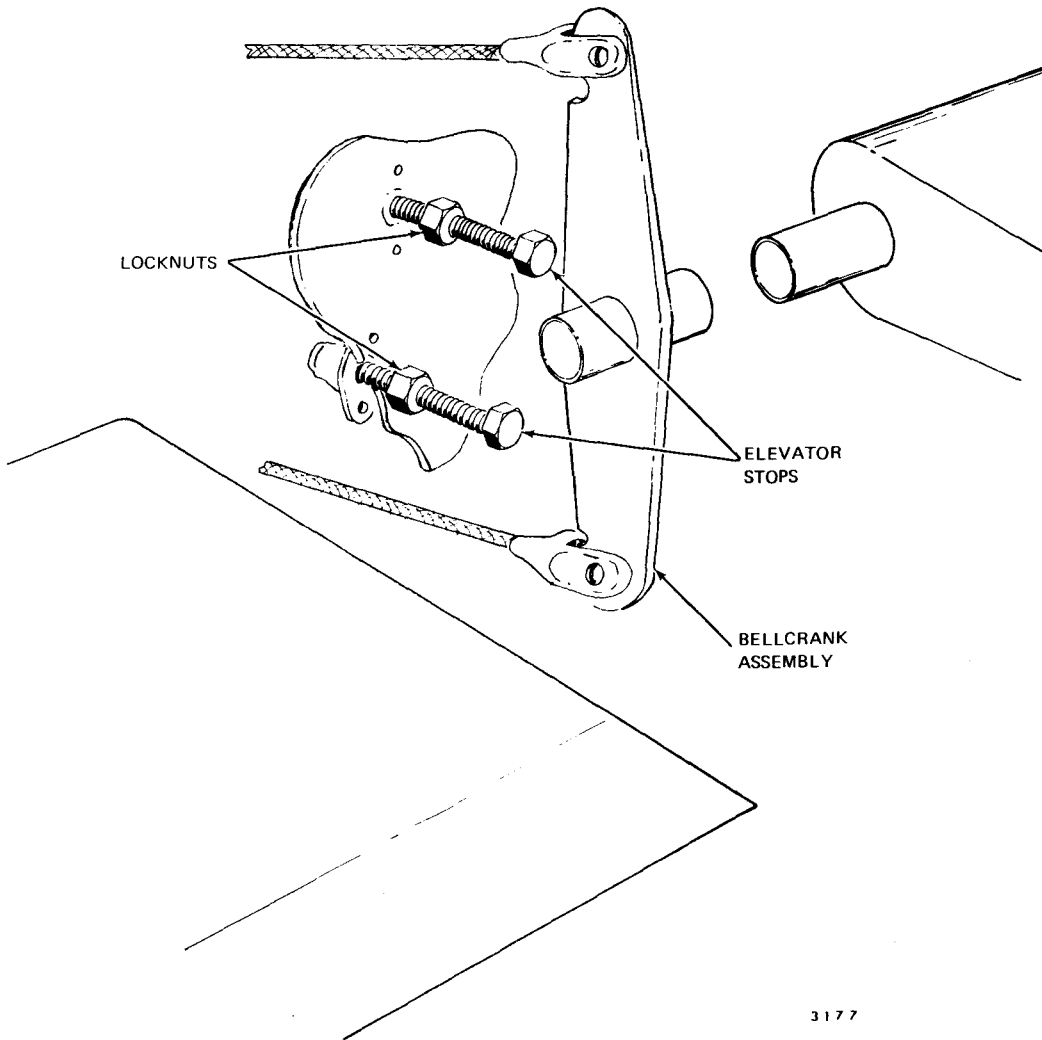

Elevator Control Stops
Figure 503

AA-5 SERIES
MAINTENANCE MANUAL

- (8) Place elevator rigging fixture (Part No. 5302050-501, Figure 504) on horizontal stabilizer, outboard of trim tab.
- (9) Move the elevator to its full up position (against the control stop) and measure the throw of the control on the rigging fixture.
- (10) Adjust the elevator stop to obtain $23^{\circ} \pm 1^{\circ}$ indication on the fixture. Tighten lock nut.
- (11) Move the elevator to its full down position (against the control stop) and measure the throw of the control on the rigging fixture.
- (12) Adjust the elevator stop to obtain $17^{\circ} \pm 2^{\circ}$ indication on the fixture. Tighten lock nut.
- (13) Recheck cable tension, and safety turnbuckles with clips.
- (14) Replace trim per Chapter 25.
- (15) Install tailcone per Chapter 53.

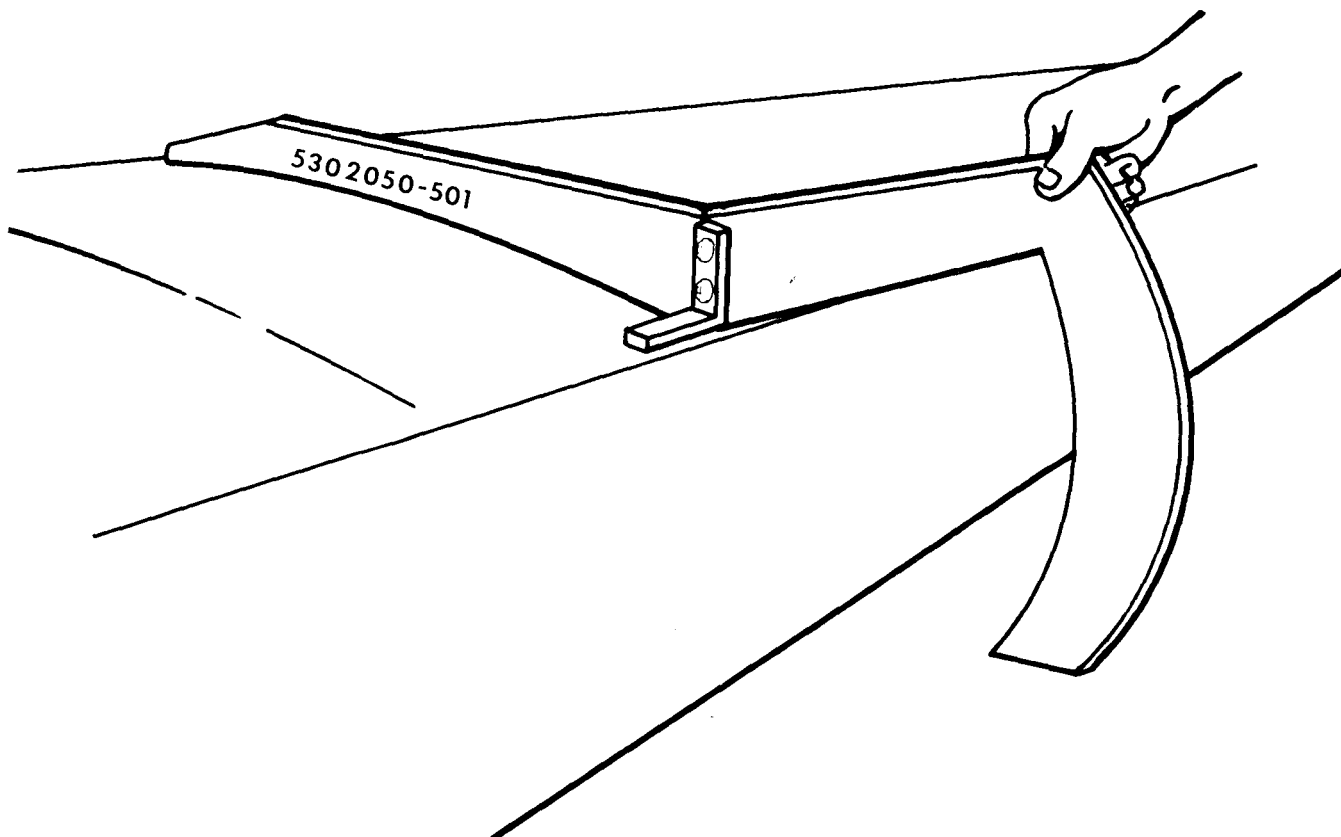

Elevator Rigging Fixture
Figure 504

AA-5 SERIES
MAINTENANCE MANUAL

D. Trim Tab Rigging (AA-5 Aircraft)

NOTE: Elevator rigging should always be checked prior to checking or changing trim tab rigging.

- (1) Run trim wheel to its full up position (full aft rotation).
- (2) Place trim tab rigging fixture (Part No. DE 5004-501, Figure 505) on the elevator, at the center of the trim tab span.
- (3) Position elevator to its neutral position (streamlined with horizontal stabilizer) and note reading on fixture.
- (4) Fixture shall indicate $19^{\circ} \pm 2^{\circ}$ down throw of trim tab. If tab throw is not within tolerance, adjust rigging as follows:
 - (a) Position control wheel to its neutral ($0^{\circ} \pm 2^{\circ}$) position and install control lock or rigging fixture (Figure 501).
 - (b) Rotate control wheel to its full up position (full aft rotation).
 - (c) Remove console trim per Chapter 25 to provide access to trim control mechanism.
 - (d) Remove cotter pin (35, Figure 405), nut (36) and washers (37).
 - (e) Pull trim wheel (40) out until its pinion (42) clears the drive pinion (31).

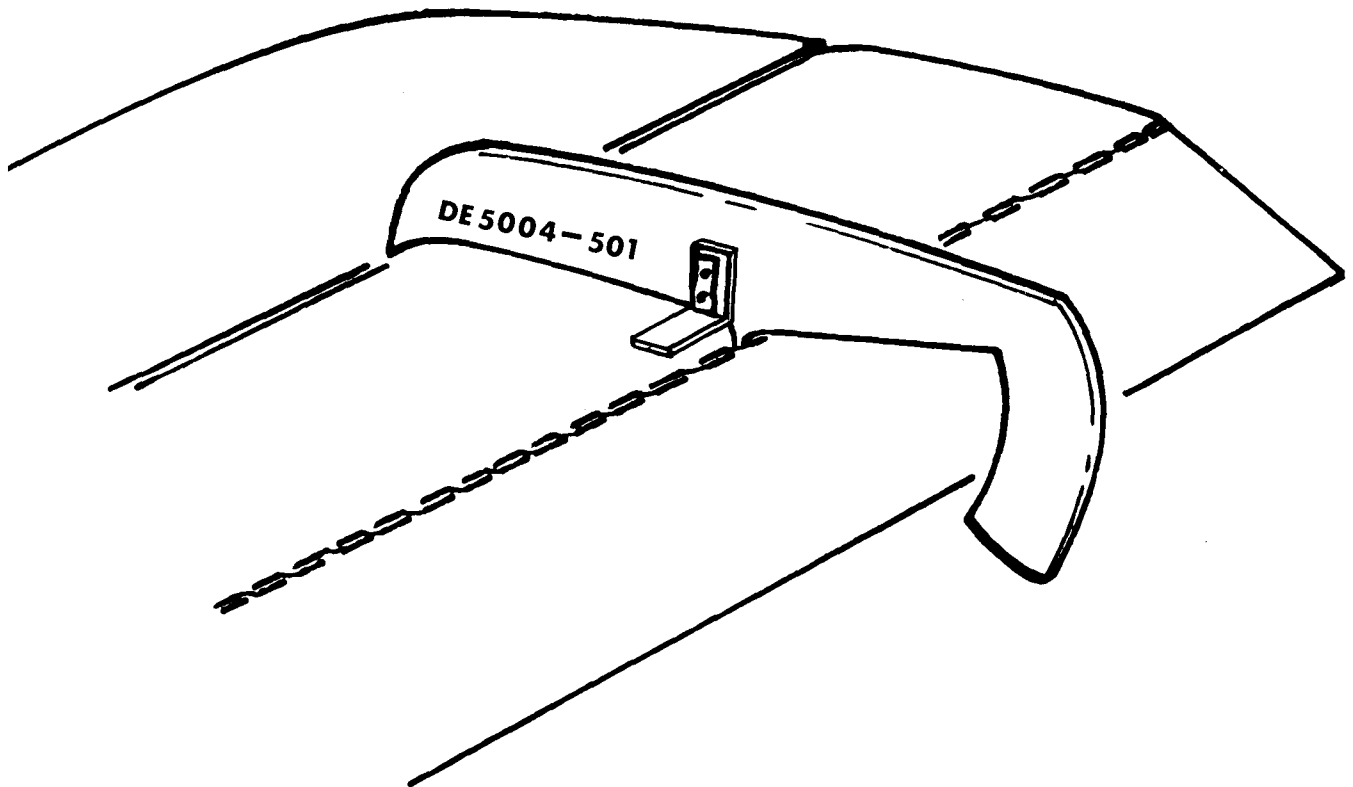

Trim Tab Rigging Fixture
Figure 505

- (f) Rotate flexible shaft (25) until the trim tab down throw is $19^{\circ} \pm 2^{\circ}$.
- (g) Push the trim wheel (40) in to engage the pinion gears (42 and 31). Secure with washers (37), nut (36) and cotter pin (35).
- (h) Rotate trim wheel (40) until the trim tab is in the neutral (0°) position.
- (i) Bend indicator wire on trim indicator bracket (48) to agree with "N" on trim indicator.
- (j) Remove rigging fixture (Figure 505) and control lock (or rigging fixture, Figure 501).
- (k) Check trim system for freedom of movement.
- (l) Reinstall console trim per Chapter 25.

E. Trim Tab Rigging (AA-5A and AA-5B Aircraft)

NOTE: Elevator rigging should always be checked prior to checking or changing trim tab rigging.

- (1) Run trim wheel to its full up position (full aft rotation).
- (2) Place trim tab rigging fixture (Part No. DE 5004-502, Figure 505) on the elevator, at the trim tab hinge cutout area.
- (3) Position elevator to its neutral position (streamlined with horizontal stabilizer) and note reading on fixture.
- (4) Fixture shall indicate $29^{\circ} \pm 1^{\circ}$ up throw of trim tab. If tab throw is not within tolerance, adjust rigging as follows:
 - (a) Position control wheel to its neutral ($0^{\circ} \pm 2^{\circ}$) position and install control lock or rigging fixture (Figure 501).
 - (b) Rotate control wheel to its full up position (full aft rotation).
 - (c) Remove console trim per Chapter 25 to provide access to trim control mechanism.
 - (d) Remove cotter pin (35, Figure 405), nut (36) and washers (37).
 - (e) Pull trim wheel (40) out until its pinion (42) clears the drive pinion (31).
 - (f) Rotate flexible shaft (25) until the trim tab throw is $29^{\circ} \pm 1^{\circ}$.
 - (g) Push the trim wheel (40) in to engage the pinion gears (42 and 31). Secure with washers (37), nut (36) and cotter pin (35).
 - (h) Rotate trim wheel (40) until the trim tab is in the neutral (0°) position.
 - (i) Bend indicator wire on trim indicator bracket (48) to agree with "N" on trim placard.
 - (j) Remove rigging fixture (Figure 505) and control lock (or rigging fixture, Figure 501).

2. Elevator Balancing

Refer to Section 27-1-1 for control surface balancing procedures.

AA-5 SERIES
MAINTENANCE MANUAL

3. Elevator Trim Tab Free Play Measurement (AA-5A and AA-5B aircraft)

It has been determined that the amount of free play at the elevator trim tab is an indicator of the effectiveness of the tab in fulfilling the requirements for irreversibility. The procedures outlined below provide a means to determine the general condition and amount of wear sustained by certain trim system components.

A. Preparation

- (1) Move the aircraft into a hangar or other protected location so that wind or other air disturbances do not interfere with the control surfaces.
- (2) Set the parking brake or install wheel chocks. Provide support for the fuselage at or near the aft bulkhead to steady the aircraft.
- (3) Fair the elevator with the horizontal stabilizer and use plywood or blocks and long 1/8-inch bolts as shown in Figure 507 to hold the elevators in this position during the remainder of the proceedings.
- (4) Using the trim tab control wheel, fair the trim tab and elevator trailing edges.

NOTE: The trim tab control wheel should not be moved again until the measurements are completed. Procedures given below are for one trim tab only, and must be repeated on the other trim tab.

- (5) Using tape or other means, fasten a flat, thin piece of suitable material to the trim tab trailing edge to act as a reference pointer as shown in Figure 507.
- (6) Fasten a 6-inch scale to the elevator trailing edge as shown in Figure 507.
- (7) Provide a 2 ± 0.05 -pound weight and safety wire or other means to suspend it from the slot in the trim tab arm. (See Figure 507.)

NOTE: An unopened quart can of aircraft engine oil, and a suitable length of safety wire fashioned to hold the can, as shown in Figure 507 weigh approximately two pounds. Any discrepancy can be corrected by placing suitable washers or other small parts on the can.

B. Measurement of Free Play

- (1) Using 8 to 10 pounds of hand pressure, press down on the elevator trim tab at the inboard end to remove all of the slack from the system.
 - (2) Slowly release the hand pressure to zero and remove the hand from the trim tab. Note the position of the reference pointer relative to the scale.
- NOTE: After the initial measurement is taken, the positions of the elevator, index, and scale must not be disturbed.
- (3) Suspend the balance weight (2 ± 0.05 pounds) at the forward end of the slot in the trim tab arm. Do not allow the balance weight to slip from the forward end of the slot.
 - (4) Using 8 to 10 pounds of hand pressure, press up on the elevator trim tab at the inboard end to remove all of the slack from the system.
 - (5) Slowly release the hand pressure to zero and remove the hand from the trim tab. Note the position of the reference pointer relative to the scale.
 - (6) Using the scale readings obtained in Steps (2) and (5) above, subtract the smaller from the larger to obtain the net free play. Note the net free play measurement.
 - (7) Remove the balance weight from the trim tab arm. Repeat Steps (1) through (6) above to obtain a second net free play measurement.
 - (8) If the difference between the two net free play measurements is 0.020 inch or less, calculate the average of the two values (add them together, then divide by 2). The maximum allowable free play is 0.27 inch.
 - (9) If the difference between the two net free play measurements is more than 0.020 inch, repeat Steps (1) through (7) above to obtain two more net free play measurements. Discard the highest and lowest of the four values obtained. Calculate the average of the two values (add them together, then divide by 2). The maximum allowable free play is 0.27 inch.
 - (10) If the free play exceeds 0.27 inch, excessive wear to the trim tab arm system components may be indicated. Refer to Maintenance Practices — Removal/Installation, paragraph entitled "Elevator Trim Tab Free Play Reduction."

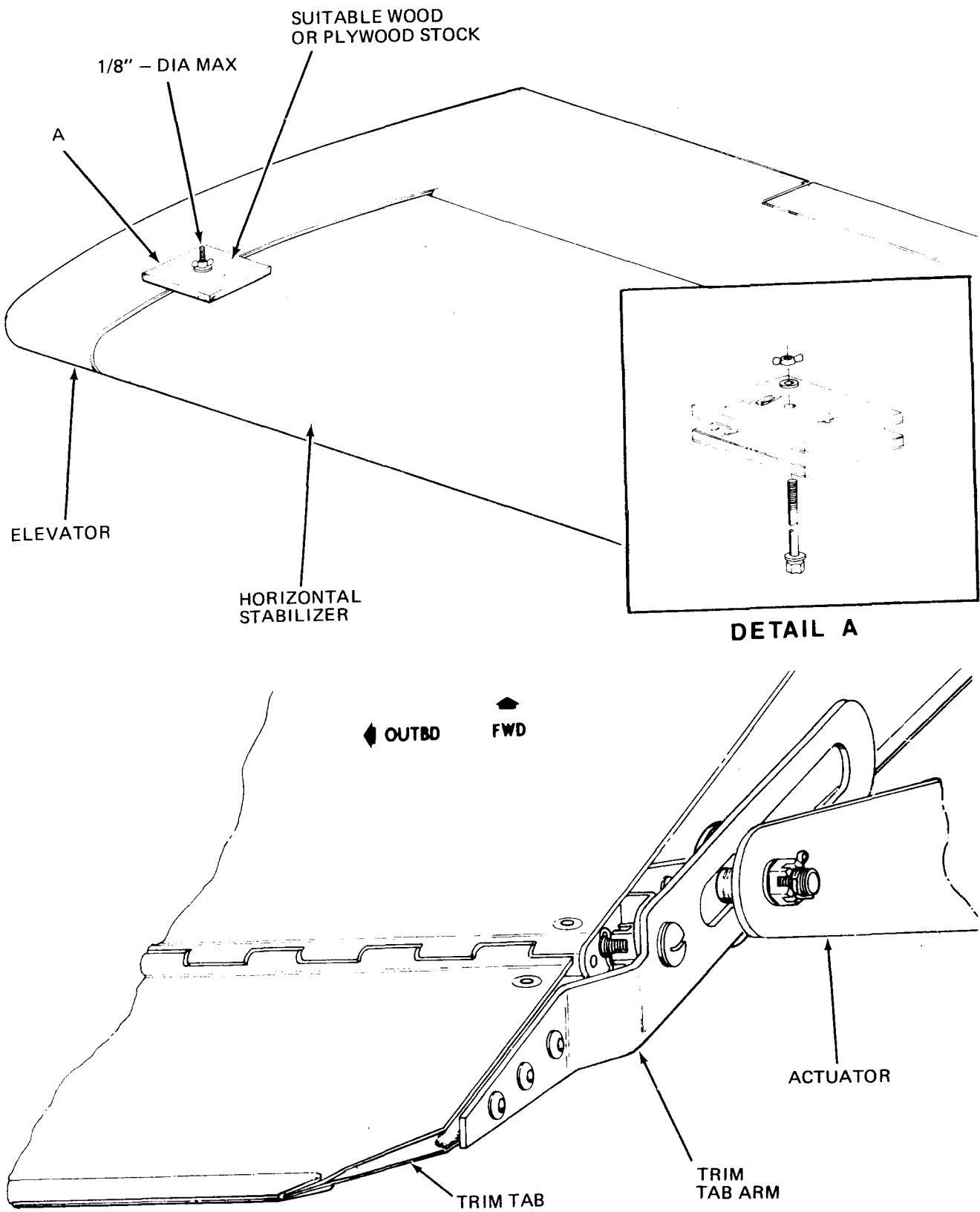

Figure 507. Elevator Trim Tab Free Play Measurement
(Sheet 1 Of 2)

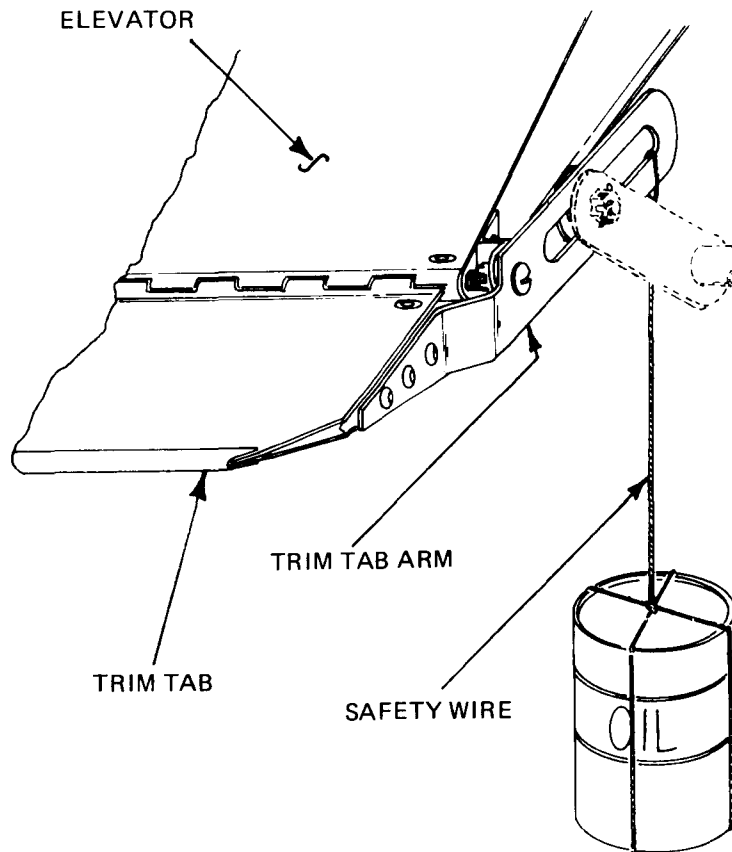
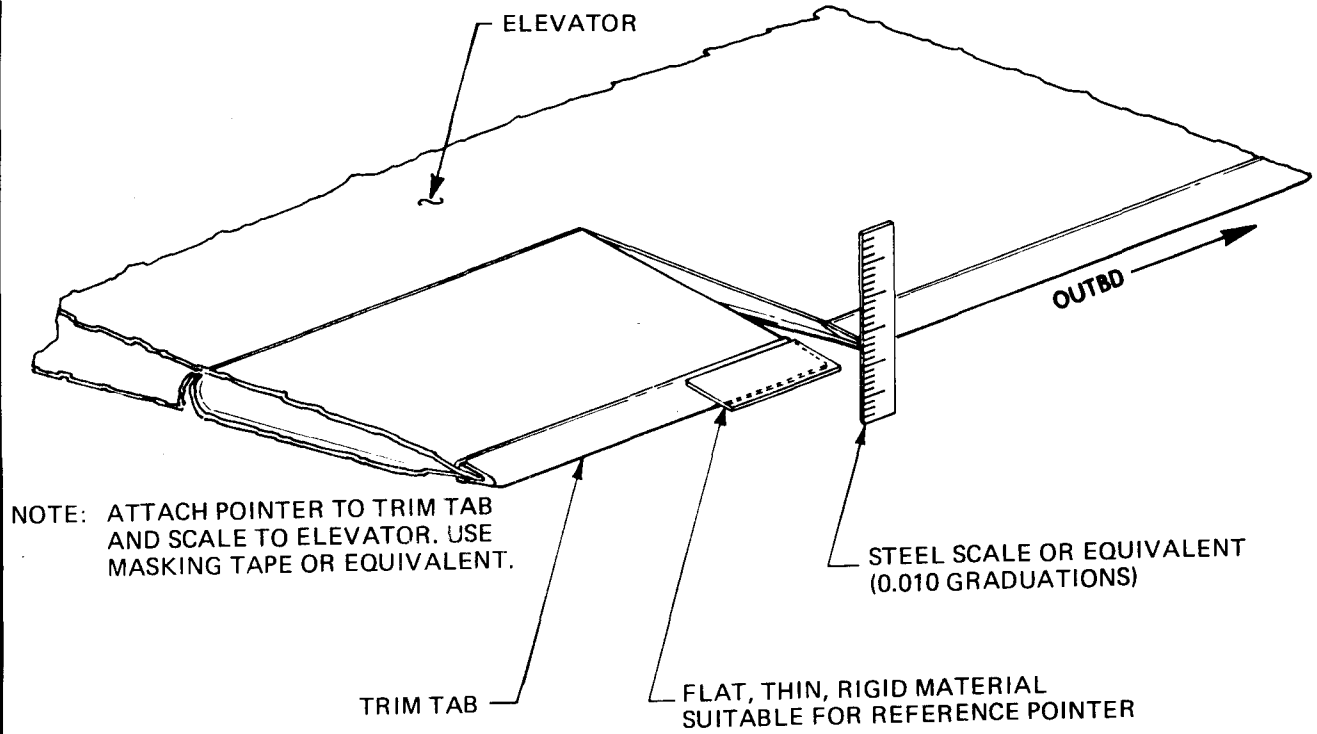

Figure 507. Elevator Trim Tab Free Play Measurement
(Sheet 2 Of 2)

MAINTENANCE PRACTICES — CLEANING/PAINTING

1. General

CAUTION: WHEN CONTROL SURFACES ARE PAINTED THEIR BALANCE IS CHANGED. ALWAYS CHECK BALANCE AFTER PAINTING.

Refer to Chapter 20 for proper cleaning and painting procedures.

AA-5 SERIES
MAINTENANCE MANUAL

FLAPS - DESCRIPTION/OPERATION

1. General (See Figure 1.)

The flap system consists of two flaps, one on each wing, mounted inboard of the ailerons, an electrically driven actuator, and mechanical linkages to actuate the flaps. The electrical motor is controlled by a toggle-type switch mounted on the console, and flap position is indicated by a mechanically positioned tab on the console.

2. Flap Structure (See Figure 2.)

The flap structure consists of honeycomb ribs bonded to two stiffener tubes extending the length of the flap, and an aluminum skin bonded to the ribs. Each of the ribs contains a hole along its hinge line. These holes contain bearings to accommodate the aileron torque tube, over which the flaps fit. The flap torque tube fits over the aileron torque tube, and actuates the flap by means of a horn bolted to the root flap rib.

3. Flap Drive and Linkage (See Figure 3.)

The flaps are positioned by a reversible DC motor. When this motor is actuated, it turns a worm drive gear in the gearbox. The driven gear actuates a screw mechanism to move the push-pull linkage. This linkage is attached to a horn on the center torque tube, thus as the push-pull linkage moves the center torque tube rotates. The center torque tube is attached, through adjustable linkages and horn assemblies, to the flap torque tubes. Thus, as the center torque tube rotates, the flap torque tubes rotate the same amount. This arrangement provides a large mechanical advantage for the DC motor so that it can move the flaps against the aerodynamic load imposed in flight. In addition, it is a "one-way" mechanism that effectively locks the flaps in position when the motor is stopped.

Flap position is indicated by means of an indicator on the console. This indicator is positioned by a flexible cable actuated by an arm attached to the push-pull linkage.

Flap travel is limited by microswitches located adjacent to the push-pull linkage. As this linkage moves to each limit of travel, a cam on the linkage actuates a microswitch to remove power from the motor.

4. Flap Electrical System (See Figure 4.)

The flap electrical system receives DC voltage from the bus through a 15-amp fuse. This voltage is applied to one arm of the double pole, double throw flap switch.

When this switch is held in the DOWN position (aft position), voltage is routed through the normally-closed contacts of the down limit switch, through the orange (ORN) lead, to the flap motor. The ground return for the flap motor is through its black (BLK) lead, and through the other arm of the flap switch to ground.

The flap motor drives the flaps down until the limit of downward movement is reached. At this point the down limit switch is opened, breaking the DC voltage supply for the flap motor, thus causing the motor to stop.

The flap switch is spring-loaded so that when it is released it moves from the down position to the neutral position.

When the flap switch is set to UP (forward position), voltage is routed through the flap switch, the normally-closed contacts of the up limit switch, and through the black (BLK) lead of the motor. The ground return for the motor is through its orange (ORN) lead, and the other arm of the flap switch to ground.

AA-5 SERIES
MAINTENANCE MANUAL

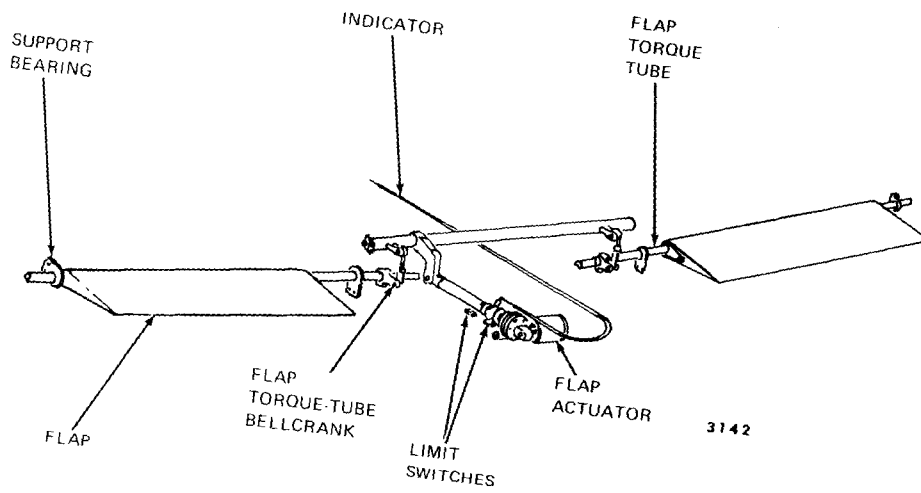

Flap System
Figure 1

AA-5 SERIES
MAINTENANCE MANUAL

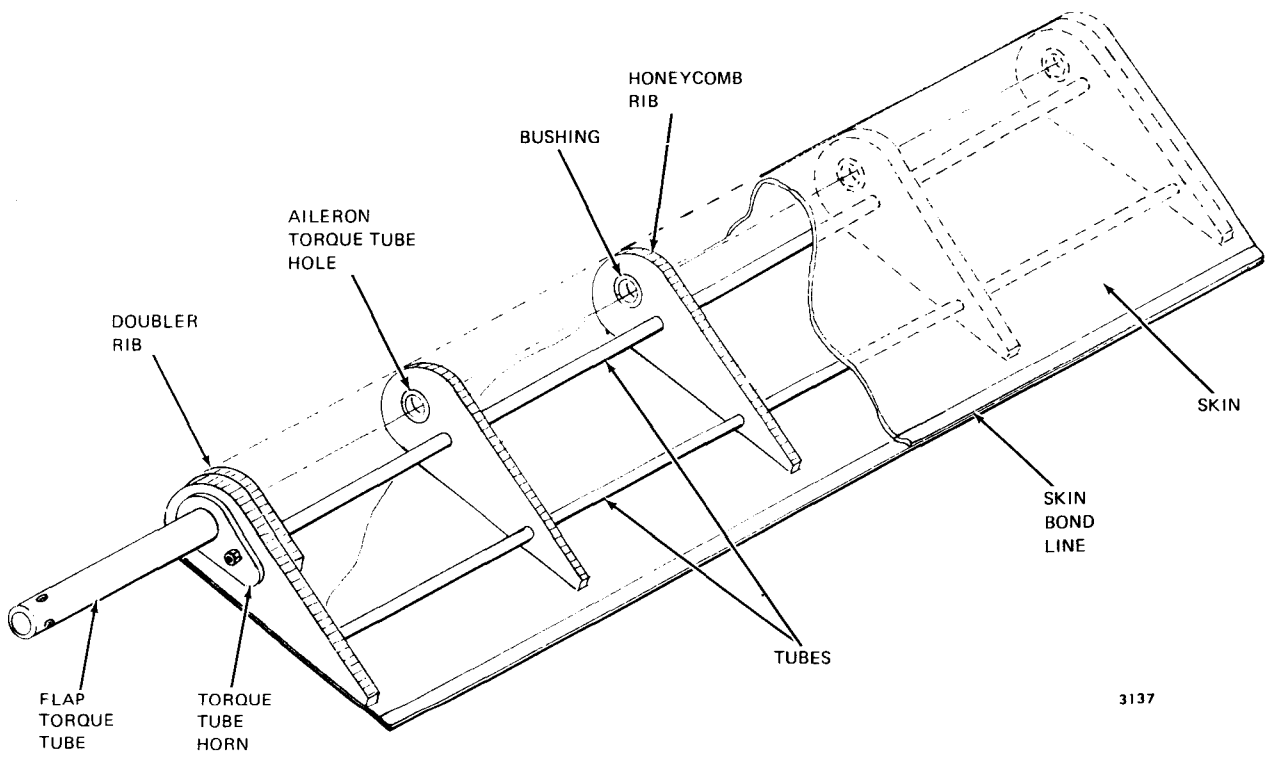

3137

Flap Surface Structure
Figure 2

AA-5 SERIES
MAINTENANCE MANUAL

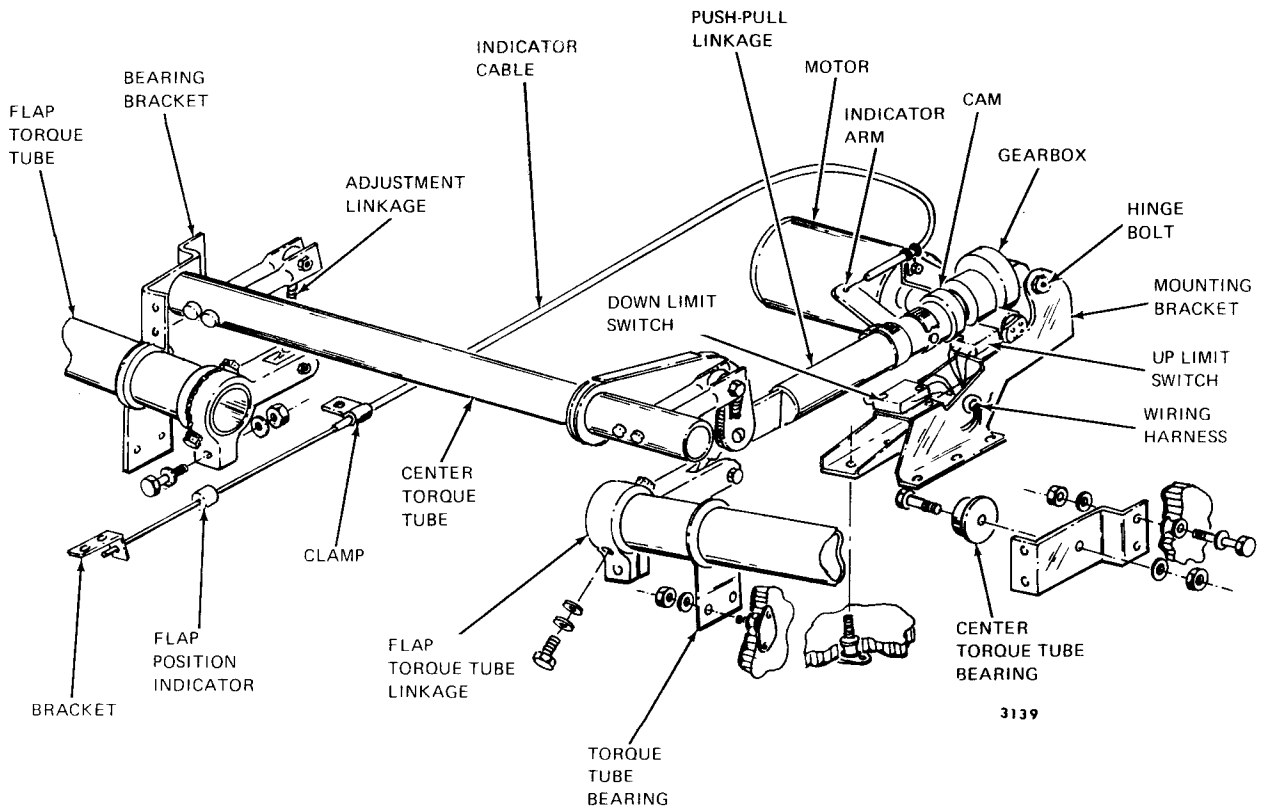

Flap Drive Mechanism
Figure 3

**AA-5 SERIES
MAINTENANCE MANUAL**

The flap motor drives the flaps up until the upward limit of travel is reached. At this point the up limit switch is opened, breaking the DC supply to the motor, causing the motor to stop. •

The flap switch has a detent in its UP position and the switch will remain in the UP position until moved out of detent.

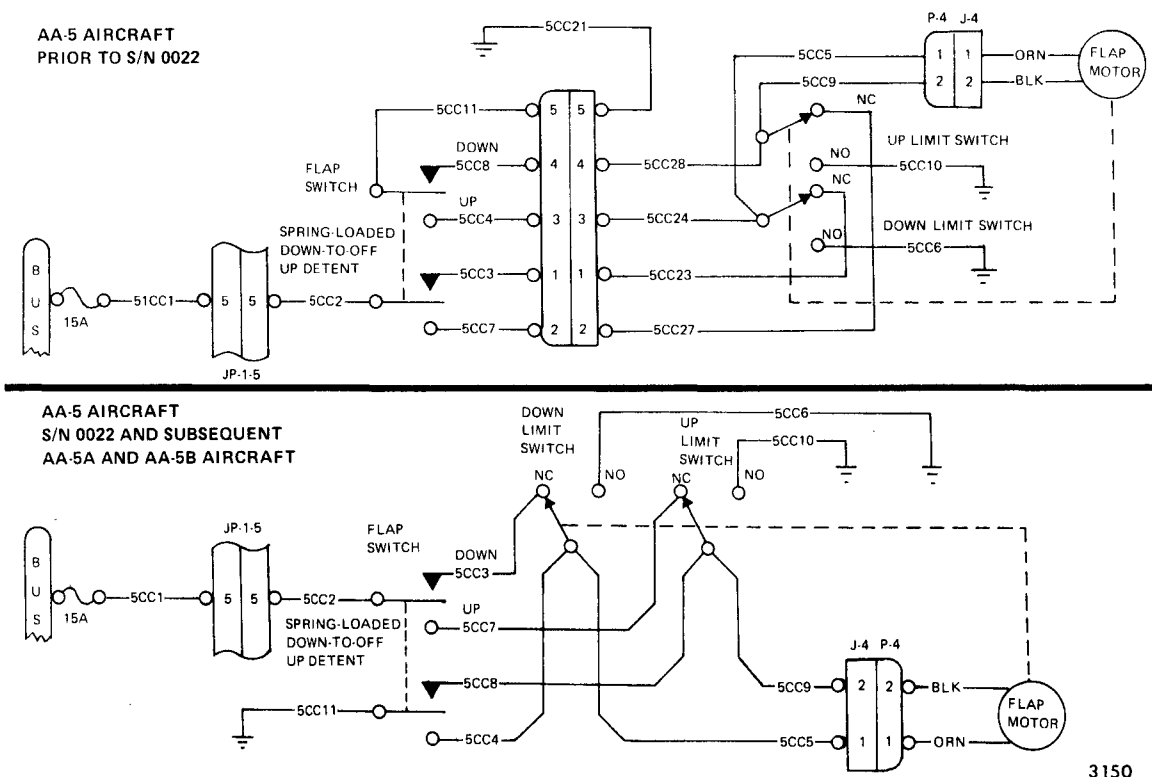

3150

Flap Electrical System Schematic
Figure 4

AA-5 SERIES
MAINTENANCE MANUAL

FLAPS – TROUBLESHOOTING

1. Troubleshooting Flaps (AA-5 Aircraft Prior to S/N 0022) (See Figure 4.)

| TROUBLE | PROBABLE CAUSE | REMEDY |
|--|--|--|
| Flaps do not move when switch is actuated. | Set MASTER switch to ON. Check fuse. | Replace if defective. |
| | Hold flap switch in DOWN position and check for 12V DC at pin 1 of connector. | If voltage is not present, replace switch. |
| | | If voltage is present, check that pin 4 of connector is grounded. If not, replace switch. |
| | Hold flap switch in UP position and check for 12V DC at pin 2 of connector. | If voltage is not present, replace switch. |
| | | If voltage is present, check that pin 3 of connector is grounded. If not, replace switch. |
| | Disconnect plug P4 from connector J4. Hold flap switch in DOWN position and jumper across down limit switch. | On plug P4, pin 1 should be positive (12V DC) with respect to pin 2. If not, check wiring. If so, replace down switch. |
| | Hold flap switch in UP position and jumper across up limit switch. | On plug P4, pin 2 should be positive (12V DC) with respect to pin 1. If not, check wiring. If so, replace up limit switch. |
| Reconnect plug P4 to connector J4 and actuate flap switch. | If flaps do not move, check motor, jackscrew, and linkages. Replace as required. | |
| Flaps move past up or down limit. | Check limit switches. | Adjust flap rigging per Adjustment/Test, Paragraph 1, or replace limit switch. |

AA-5 SERIES
MAINTENANCE MANUAL

2. Troubleshooting Flaps (AA-5 Aircraft S/N 0022 and Subsequent, AA-5A and AA-5B) (See Figure 4.)

| TROUBLE | PROBABLE CAUSE | REMEDY |
|--|--|--|
| Flaps do not move when switch is actuated. | Set MASTER switch to ON. Check fuse. | Replace fuse if defective. |
| | Hold flap switch in DOWN position and check for 12V DC at normally-closed and contact of down limit switch. | If voltage is not present, replace flap switch. |
| | | If voltage is present, check that pin 2 of J4 is grounded. If not, replace flap switch. |
| | Hold flap switch in UP position and check for 12V DC at normally-closed contact of up limit switch. | If voltage is not present, replace flap switch. |
| | | If voltage is present check that pin 1 of J4 is grounded. If not replace flap switch. |
| | Disconnect plug P4 from connector J4. Hold flap switch in DOWN position and jumper across down limit switch. | On plug P4, pin 1 should be positive (12V DC) with respect to pin 2. If not, check wiring. If so, replace down limit switch. |
| | Hold flap switch in UP position and jumper across up limit switch. | On plug P4, pin 2 should be positive (12V DC) with respect to pin 1. If not, check wiring. If so, replace up limit switch. |
| Reconnect plug P4 to connector J4 and actuate flap switch. | If flaps do not move, check motor, jackscrew, and linkage. Replace as required. | |
| Flaps move past up or down limit. | Check limit switches. | Adjust flap rigging per Adjustment/Test, Paragraph 1, or replace limit switch. |

MAINTENANCE PRACTICES – SERVICING

1. Lubrication

A. Flap Drive Jackscrew Lubrication

- (1) Set MASTER switch to ON.
- (2) Hold flap switch in DOWN (aft) position until flaps are fully deployed.
- (3) Set MASTER switch to OFF.
- (4) Remove trim per Chapter 25 to provide access to the flap drive mechanism.
- (5) Use a clean, lint-free cloth to wipe excess oil and foreign material from exposed threads of jackscrew.
- (6) Apply a light coat of MIL-L-7870 oil (See Chapter 12.) to exposed threads. Wipe off excess oil.
- (7) Install trim per Chapter 25.
- (8) Set MASTER switch to ON.
- (9) Set flap switch to UP.
- (10) When flaps have moved to the up position, set MASTER switch to OFF.

B. Torque Tube Oilite Bearing Lubrication

- (1) Remove trim per Chapter 25 to expose flap torque tube bearings.
- (2) Inject a small amount of MIL-L-7870 oil (See Chapter 12.) between torque tube and bearings.
- (3) Install trim per Chapter 25.

C. Flap Position Indicating Cable Lubrication

- (1) Remove trim per Chapter 25 to provide access to flap position indicator cable.
- (2) Remove indicator cable assembly from console per Removal/Installation, Paragraph 2A, this chapter.
- (3) Pull wire from center of cable assembly.
- (4) Use a clean, lint-free cloth to wipe all grease and foreign material from wire.
- (5) Apply a light coating of MIL-G-21164 Molybdenum Disulphide grease (See Chapter 12.) to wire.
- (6) Install wire in cable assembly.
- (7) Install cable assembly in console per Removal/Installation, Paragraph 2B.
- (8) Install trim per Chapter 25.

MAINTENANCE PRACTICES – REMOVAL/INSTALLATION

1. Flap Assembly Removal/Installation

A. Flap Assembly Removal (See Figure 401.)

- (1) Remove aileron per Section 27-1-0.
- (2) Remove trim per Chapter 25 to expose flap drive mechanism and flap torque tubes.
- (3) Remove nut (1), washer (2), and bolt (3) from arm (4).
- (4) Cut safety wire (5) and remove bolts (6) and washers (7).
- (5) Use a screwdriver or similar tool to open the slot in the arm (4) slightly, then pull the torque tube (8) outboard until it clears the aircraft.

B. Flap Assembly Installation (See Figure 401.)

- (1) Position flap on wing and slide torque tube (8) through the oilite bearing (9) and arm (4).

NOTE: Be sure that special screws are indexed properly in torque tube holes. Safety as shown in Figure 401. Use same number of washers under each bolt. Bolt should be flush minimum and extend not more than 0.032 inch through torque tube.

- (2) Align holes in arm (4) and torque tube (8) and secure with bolts (6) and washers (7). Torque to standard value per Chapter 91 and safety wire bolts (6) with 0.032 wire.
- (3) Install bolt (3), washer (2), and nut (1). Torque per Chapter 91.
- (4) Install aileron per Section 27-1-0, this chapter.
- (5) Install trim per Chapter 25.

2. Flap Drive Removal/Installation

C. Flap Drive Removal (See Figure 401.)

- (1) Remove trim per Chapter 25 to provide access to flap drive.
- (2) Remove nuts (10), washers (11), and bolts (12) from torque tube (13).
- (3) Remove nuts (14), washers (15), and bolts (16) from torque tube mounting bracket (17).
- (4) Remove cotter pin (18), nut (19), washer (20), and bolt (21) from torque tube (13) and disconnect actuator fitting (22) from horn on torque tube (13).
- (5) Remove bracket (17) from aircraft and pull bearing (23) from torque tube (13).
- (6) Remove torque tube (13) from aircraft.
- (7) Disconnect drive motor connector (24).
- (8) Remove screw (25) securing indicator cable (26) to actuator assembly and disconnect joggled end of cable from horn (27).
- (9) Remove nut (28), washer (29), bushing (30), and bolt (31) from mounting bracket (32) and lift drive mechanism (33) from aircraft.
- (10) Remove nut (34), washer (35), and screw (36) from clamp (37). Pull cable (26) from bracket (38). Remove cable (26) from console.
- (11) Remove setscrew (39), and pull indicator (40) from wire (41).

- | | | |
|-------------------|-------------------------------|----------------------|
| 1. NUT | 15. WASHERS | 29. WASHER |
| 2. WASHER | 16. BOLT | 30. BUSHING |
| 3. BOLT | 17. TORQUE TUBE MOUNT BRACKET | 31. BOLT |
| 4. ARM | 18. COTTER PIN | 32. MOUNTING BRACKET |
| 5. SAFETY WIRE | 19. NUT | 33. DRIVE MECHANISM |
| 6. BOLTS | 20. WASHERS | 34. NUT |
| 7. WASHERS | 21. BOLT | 35. WASHER |
| 8. TORQUE TUBE | 22. ACTUATOR FITTING | 36. SCREW |
| 9. OILITE BEARING | 23. TORQUE TUBE | 37. CLAMP |
| 10. NUT | 24. CONNECTOR | 38. BRACKET |
| 11. WASHERS | 25. SCREW | 39. SET SCREW |
| 12. BOLT | 26. CABLE, INDICATOR | 40. INDICATOR |
| 13. TORQUE TUBE | 27. HORN | 41. WIRE |
| 14. NUT | 28. NUT | |

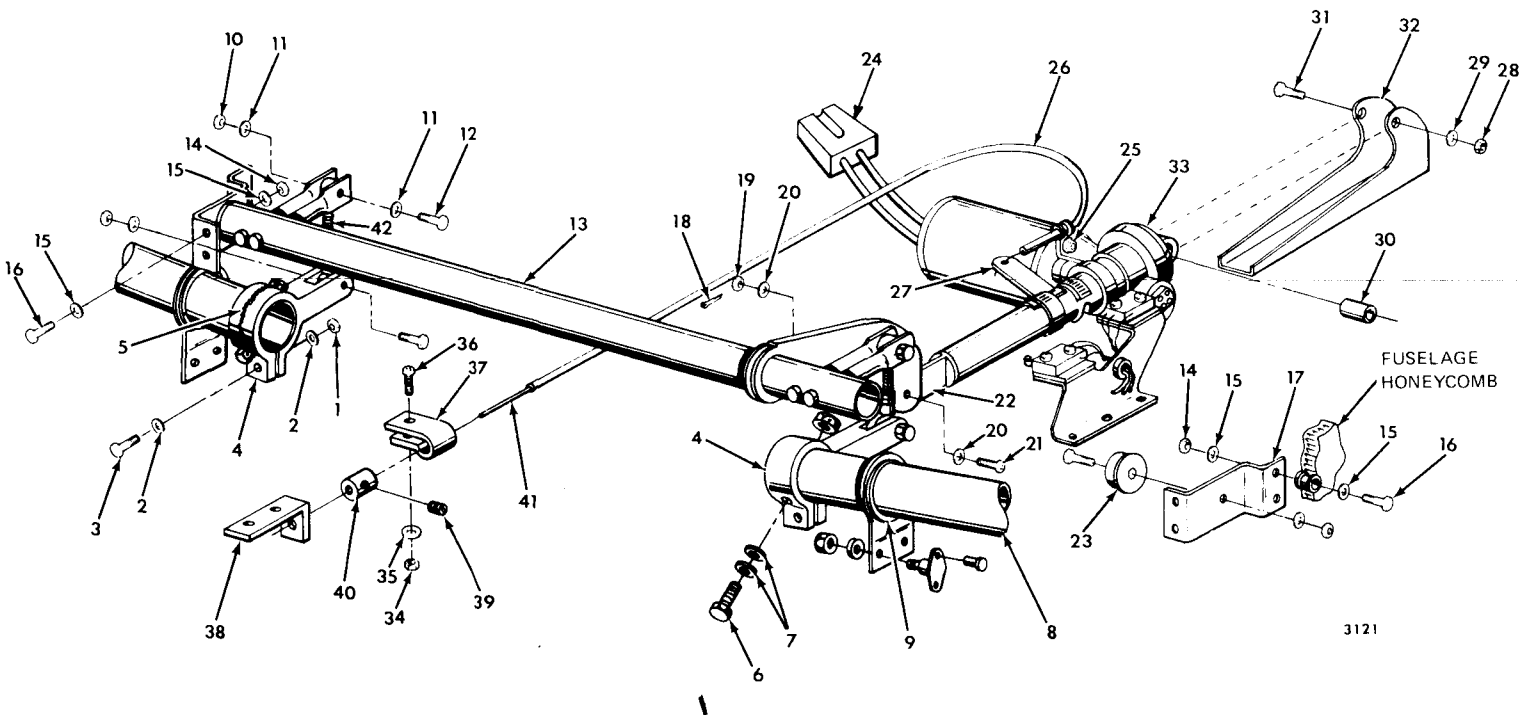

Flap Removal/Installation
Figure 401

B. Flap Drive Installation (See Figure 401.)

- (1) Insert wire (41) into indicator (40) and secure with setscrew (39).
- (2) Insert cable (26) in clamp (37) and secure to console with screw (36), washer (35), and nut (34).
- (3) Insert bearing (23) in each end of torque tube (13).
- (4) Position brackets (17) to align mounting holes. Secure to aircraft with bolts (16), washers (15), and nuts (14). Torque to standard value. (See Chapter 91.)
- (5) Insert bushing (30) in mounting hole on aft end of actuator (33). Secure actuator (33) to bracket (32) with bolt (31), washer (29), and nut (28). Torque to standard value. (See Chapter 91.)
- (6) Insert joggled end of cable (26) in arm (27) and attach cable to actuator (33) with screw (25).
- (7) Align holes in fitting (22) and the arm on the torque tube (13). Secure with bolt (21), washer (20), nut (19), and cotter pin (18).
- (8) Connect electrical connector (24) to its mating connection in the aircraft wiring bundle.
- (9) Place linkages (42) in horns on torque tube (13). Secure with bolts (12), washers (11), and nuts (10). Torque to standard value. (See Chapter 91.)

3. Flap Switch Removal/Installation

A. Flap Switch Removal (See Figure 402.)

- (1) Unscrew flap switch knob (1) from flap switch (2).
- (2) Remove console trim per Chapter 25.
- (3) Remove mounting nut (3) from flap switch (2) and pull flap switch from console.
- (4) Tag and disconnect wires.

B. Flap Switch Installation

- (1) Connect wires.
- (2) Insert flap switch (2) from underside of console, positioning locator slot in switch to correspond to tab on console.
- (3) Install mounting nut (3) on switch (2) and tighten nut.
- (4) Install trim per Chapter 25.
- (5) Screw flap knob (1) on flap switch (2).

4. Microswitch Removal/Installation

A. Microswitch Removal

- (1) Remove trim per Chapter 25 to provide access to microswitch.

AA-5 SERIES
MAINTENANCE MANUAL

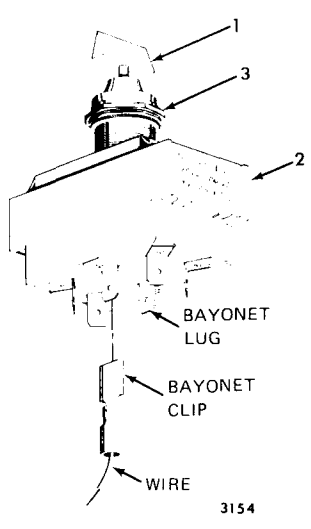
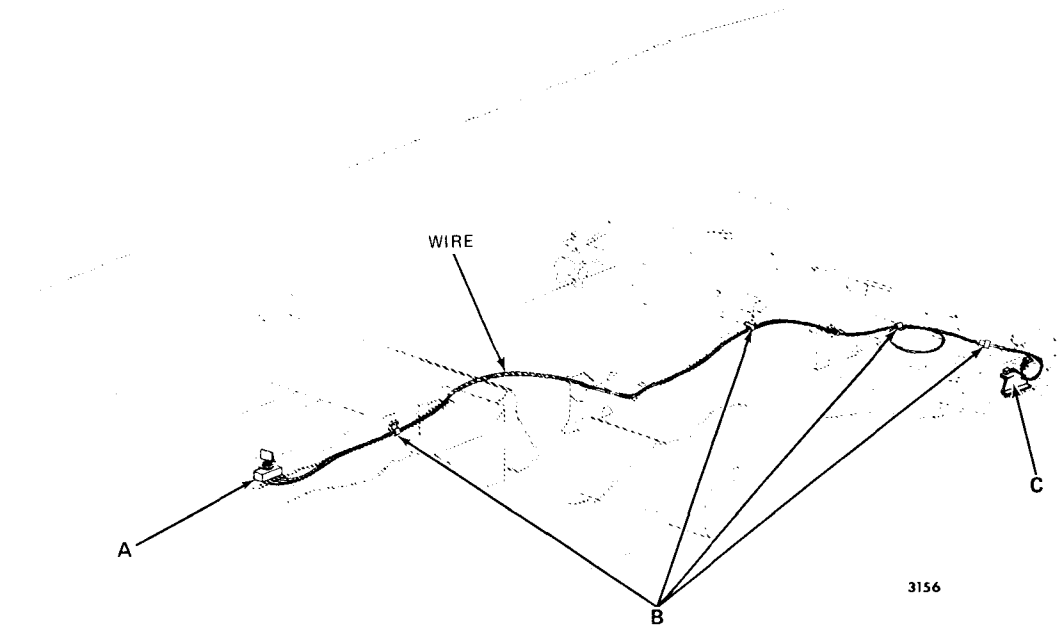

DETAIL A

1. Flap Switch Knob
2. Flap Switch
3. Mounting Nut
4. Screws
5. Microswitch
6. Pad
7. Bracket

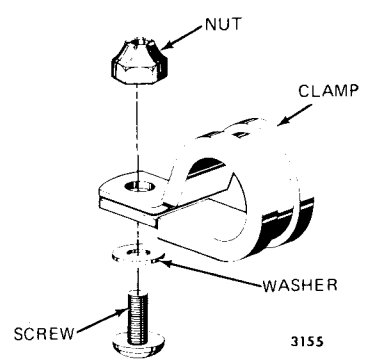

DETAIL B

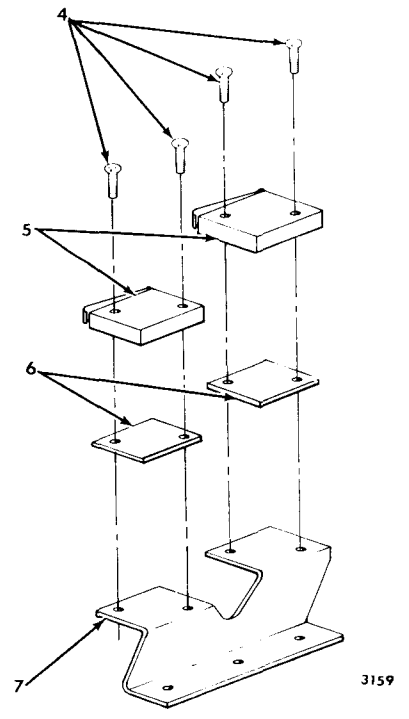

DETAIL C

Flap Wiring Removal/Installation
Figure 402

AA-5 SERIES
MAINTENANCE MANUAL

(2) Tag and disconnect wires.

(3) Remove screws (4) from microswitch (5). Lift microswitch (5) and pad (6) from bracket (7).

B. Microswitch Installation

(1) Position pad (6) on bracket (7) so that holes align.

(2) Place microswitch (5) on pad (6) and secure with screws (4).

(3) Reconnect wires.

(4) Install trim per Chapter 25.

5. Wiring Removal/Installation

A. Wiring Removal

(1) Ensure that electrical power is off prior to removing or installing wires.

(2) Disconnect wiring.

B. Wiring Installation

(1) Route wires per Figure 402.

(2) Refer to Figure 4 under (Flaps — Description/Operation) for wiring numbering and wiring diagram.

MAINTENANCE PRACTICES — ADJUSTMENT/TEST

1. Rigging

A. Flap Rigging (AA-5 Aircraft) (See Figure 501.)

- (1) Remove trim per Chapter 25 to provide access to the flap drive.
- (2) Ensure that flap switch is set to OFF.
- (3) Manually rotate rubber coupling (1) until cam (2) depresses roller on aft limit switch (3) and a click is heard from the switch. This is the fully retracted flap position.
- (4) Place rigging fixture (P/N DE 5003-501) on wing at mid-span of flap, as shown in Figure 501.

NOTE: Aerodynamic lift and normal tolerance buildup in the linkage from flap motor to flap trailing edge result in a smaller flap angle in flight than on the ground. Before taking flap angle readings, grasp the flap at the center of the trailing edge and lift upward with 5 to 10 pounds of force as required to take up any slack in the linkage. Failure to comply will result in shortened flap travel when airborne.

- (5) While holding both flaps up, note the reading on the flap rigging fixture. Flaps should be 0 degree \pm 1 degree with no more than 1 degree difference between left and right flap readings.
- (6) If flap readings are not as given in Step (5), loosen locknuts (4) and adjust rod ends (5) to provide proper flap position. Tighten locknuts (4) when proper flap position is obtained.
- (7) Check flap position indicator in forward console for correct alignment. If adjustment is required, loosen the setscrew in the indicator and position as required.
- (8) With power on, cycle the flaps to the full down position, then back up until stopped by the aft limit switch (3). Check the flap position as in Steps (5) and (6) above. Hold the flap switch in the DOWN position until the flaps are stopped by the forward limit switch (6). With the flaps held up to remove slack (See NOTE above.), the flap rigging fixture should indicate 30 degrees \pm 3 degrees. Adjust forward limit switch (6) as required to obtain this condition.
- (9) Move cam (2) past front limit switch (6) by turning rubber coupling (1) until end stop in jackscrew is reached. Check for positive clearance between flap actuation parts and aileron torque tubes.
- (10) Install trim per Chapter 25.

B. Flap Rigging (AA-5A and AA-5B Aircraft) (See Figure 501.)

- (1) Remove trim per Chapter 25 to provide access to the flap drive.
- (2) Ensure that flap switch is set to OFF.
- (3) Manually rotate rubber coupling (1) until cam (2) depresses roller on aft limit switch (3) and a click is heard from the switch. This is the fully retracted flap position.
- (4) Place rigging fixture (P/N DE 5003-501) on wing at mid-span of flap, as shown in Figure 501.

AA-5 SERIES
MAINTENANCE MANUAL

NOTE: Aerodynamic lift and normal tolerance buildup in the linkage from flap motor to flap trailing edge result in a smaller flap angle in flight than on the ground. Before taking flap angle readings, grasp the flap at the center of the trailing edge and lift upward with 5 to 10 pounds of force as required to take up any slack in the linkage. Failure to comply will result in shortened flap travel when airborne.

- (5) While holding both flaps up, note the reading on the flap rigging fixture. Flaps should be $0 \text{ degree} \pm 1 \text{ degree}$ with no more than 1 degree difference between left and right flap readings.
- (6) If flap readings are not as given in Step (5), loosen locknuts (4) and adjust rod ends (5) to provide proper flap position. Tighten locknuts (4) when proper flap position is obtained.
- (7) Check flap position indicator in forward console for correct alignment. If adjustment is required, loosen the setscrew in the indicator and position as required.
- (8) With power on, cycle the flaps to the full down position, then back up until stopped by the aft limit switch (3). Check the flap position as in Steps (5) and (6) above. Hold the flap switch in the DOWN position until the flaps are stopped by the forward limit switch (6). With the flaps held up to remove slack (See NOTE above.), the flap rigging fixture should indicate $45 \text{ degrees} \pm 2 \text{ degrees}$. Adjust forward limit switch (6) as required to obtain this condition.
- (9) Move cam (2) past front limit switch (6) by turning rubber coupling (1) until end stop in jackscrew is reached. Check for positive clearance between flap actuation parts and aileron torque tubes.
- (10) Install trim per Chapter 25.

1. Coupling
2. Cam
3. Aft Limit Switch
4. Locknuts
5. Rod End
6. Front Limit Switch

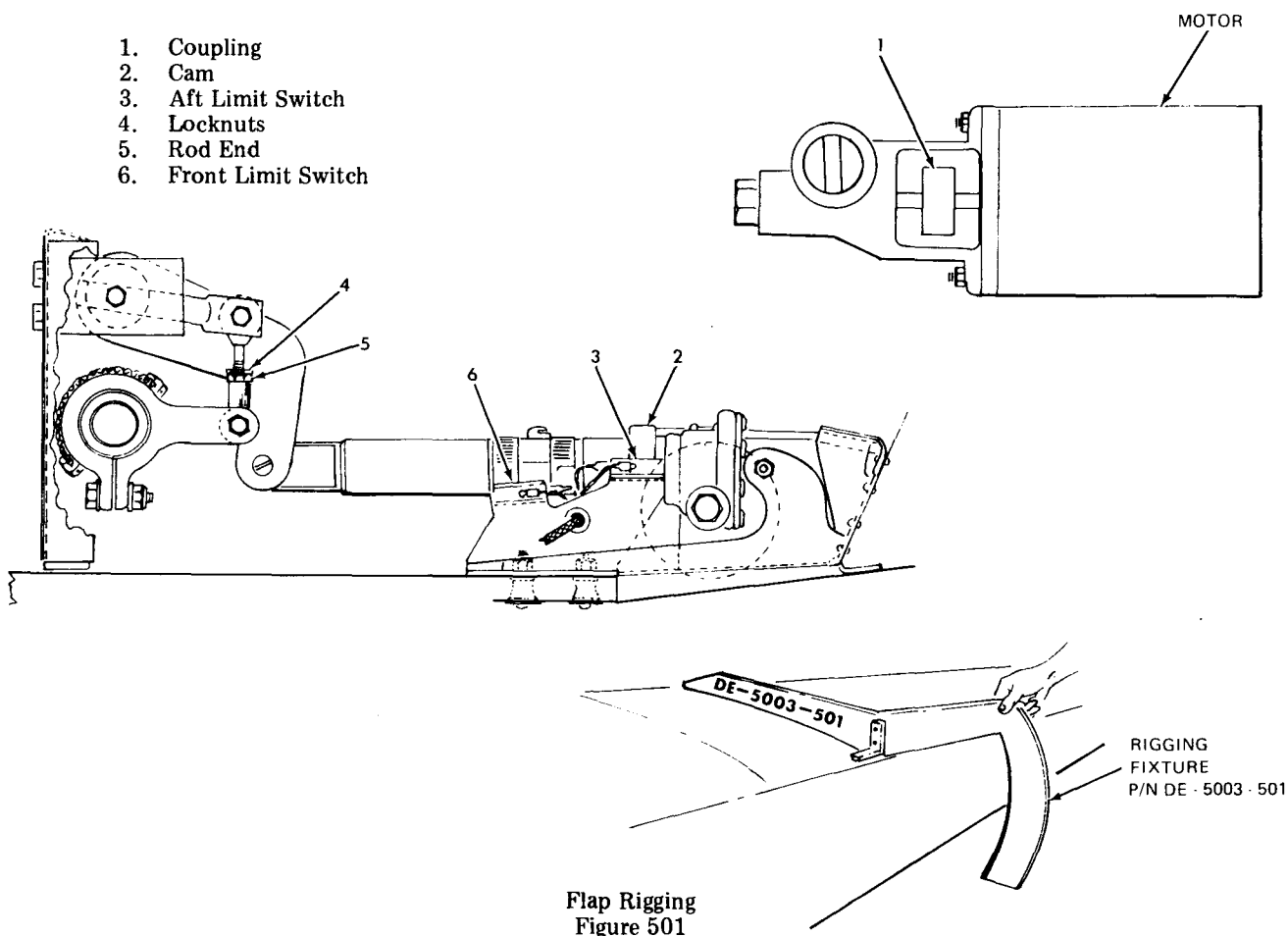

MAINTENANCE PRACTICES - CLEANING/PAINTING

1. Cleaning/Painting

Refer to Chapter 20 for proper cleaning and painting procedures.

AA-5 SERIES
MAINTENANCE MANUAL

GUST LOCK - DESCRIPTION/OPERATION

1. General (See Figure 1.)

The gust lock is composed of a formed metal rod attached to a placard tab. The lock is installed by positioning the control wheel until the hole in its shaft is aligned with the hole in its guide, and inserting the gust lock pin.

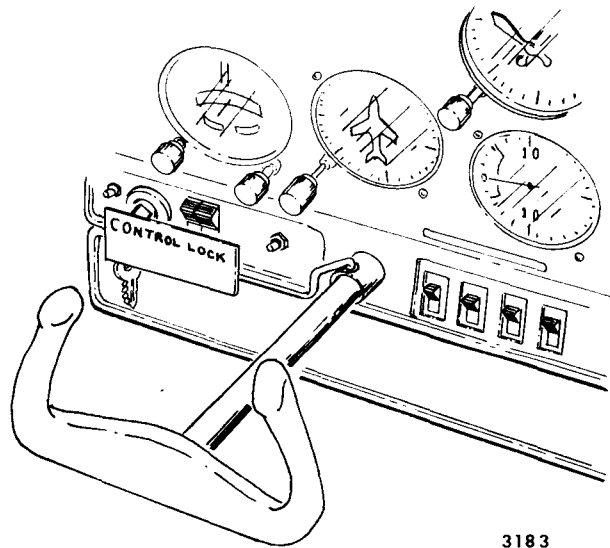

Gust Lock
Figure 1

STALL WARNING SYSTEM — DESCRIPTION/OPERATION

1. General (See Figure 1.)

The stall warning system is an electrically operated aural warning that informs the pilot of an impending stall at approximately 4 to 9 knots (5 to 10 mph) prior to stall. This system is composed of a stall sensor switch, wiring, and a stall warning horn. On Aircraft AA5-0001 through 0834, AA5A-0001 through 0054, and AA5B-0001 through 0181, a time delay controller is installed. The controller introduces a time delay of approximately one second to prevent the stall warning system from being momentarily activated by turbulence.

DC power from the aircraft bus is applied through a 5-amp fuse to the stall warning system. On Aircraft AA5A-0055 and subsequent, and AA5B-0182 and subsequent, the DC power is applied directly to one side of the stall warning horn. The other side of this horn is connected to the normally-open stall sensor switch. When the aircraft approaches to within 4 to 9 knots (5 to 10 mph) of its stalling speed, the stall sensor switch closes, completing the ground to the stall warning horn. The horn then sounds as long as the switch remains closed.

On Aircraft AA5-0001 through 0834, AA5A-0001 through 0054, and AA5B-0001 through 0181, input power is applied to the time delay controller. This controller is connected to the stall warning horn, one side of which is connected to the stall sensor switch. When the stall sensor switch is closed (due to impending stall) the time delay controller circuit is activated. After a delay of approximately one second, an electronic switch in this circuit applies DC voltage to the stall warning horn through its red lead. Since the yellow lead of the stall warning horn is grounded, the horn sounds as long as the stall sensor switch remains closed. When the stall sensor switch opens, the electronic switch in the time delay controller resets so that a one-second delay is again introduced when the stall sensor switch is closed.

The stall sensor switch is mounted on the leading edge of the right wing. The stall warning horn is mounted on a bracket beneath the left side of the instrument panel. On Aircraft AA5-0001 through 0834, AA5A-0001 through 0054 and AA5B-0001 through 0181, the time delay controller is mounted adjacent to the stall warning horn.

**AA-5 SERIES
MAINTENANCE MANUAL**

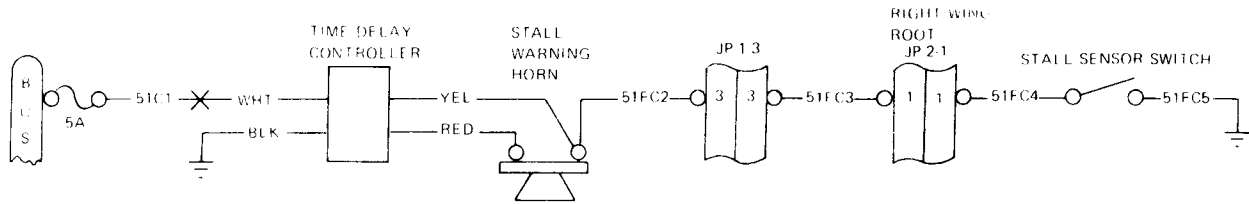

AA5-0001 THROUGH 0834
AA5A-0001 THROUGH 0054
AA5B-0001 THROUGH 0181

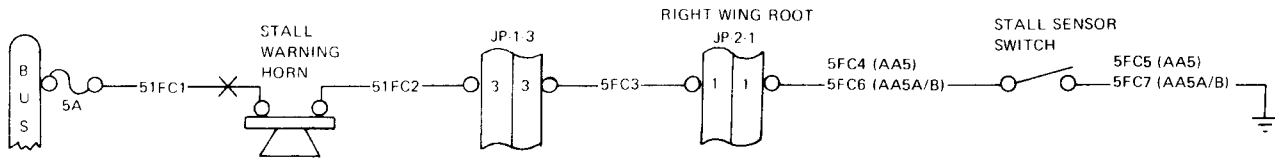

AA5-0835 AND SUBSEQUENT
AA5A-0055 AND SUBSEQUENT
AA5B-0182 AND SUBSEQUENT

3151

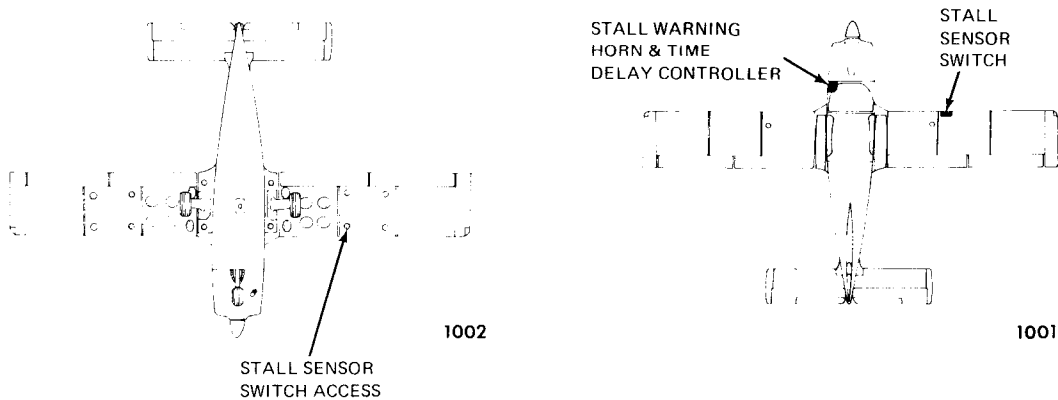

Stall Warning System
Figure 1

AA-5 SERIES
MAINTENANCE MANUAL

STALL WARNING SYSTEM — TROUBLESHOOTING

1. Troubleshooting Stall Warning System (Aircraft AA5-0001 through 0834, AA5A-0001 through 0054, and AA5B-0001 through 0181) (See Figures 1 and 401.)

| TROUBLE | PROBABLE CAUSE | REMEDY |
|---|---|--|
| Horn fails to sound when sensor switch is closed. | Set MASTER switch to ON. Check fuse. | Replace if defective. |
| | Check that black lead of time delay controller is grounded. | Establish proper ground. |
| | Check that yellow lead of time delay controller is grounded when stall sensor switch is closed. | Check wiring and switch. Repair or replace if defective. |
| | Check that 12V is present on red lead of time delay controller within 1 second after stall sensor switch is closed. | If 12V is present, replace stall warning horn. If 12V is not present, replace time delay controller. |
| Horn remains on when sensor switch is open. | Disconnect the stall switch sensor. | If horn stops, replace sensor. If not, reconnect sensor. |
| | Check that yellow lead of time delay controller is not grounded. | If not, repair wiring between controller and switch. If yes, replace time delay controller. |

2. Troubleshooting Stall Warning System (Aircraft AA5A-0055 and subsequent, and AA5B-0182 and subsequent) (See Figures 1 and 401.)

| TROUBLE | PROBABLE CAUSE | REMEDY |
|---|--|---|
| Horn fails to sound when sensor switch is closed. | Set MASTER switch to ON. Check fuse. | Replace if defective. |
| | Check that pin 3 of JP-1-3 is grounded when stall sensor switch is closed. | If not, repair wiring or replace switch. If grounded, replace stall warning horn. |

MAINTENANCE PRACTICES – REMOVAL/INSTALLATION

1. Stall Sensor Switch Removal/Installation

A. Stall Sensor Switch Removal (See Figure 401.)

- (1) Remove access cover (1) from bottom of wing.
- (2) Remove screws (2) securing sensor switch (3) to wing (4).
- (3) Tag and disconnect wires (5) and remove sensor switch (3) from inside of wing (4).
- (4) Ensure that insulating strip (6) is not damaged.

B. Stall Sensor Switch Installation (See Figure 401.)

- (1) Check that insulation strip (6) is in position beneath switch mounting location.
- (2) Connect wires (5) to sensor switch (3).
- (3) Position sensor switch (3) inside wing (4) and secure with screws (2).
- (4) Adjust sensor switch per Adjustment/Test, Paragraph 1.
- (5) Install access cover (1).

2. Stall Warning Horn Removal/Installation

A. Stall Warning Horn Removal (See Figure 401.)

- (1) Tag wires (7).
- (2) Remove nuts (8), washers (9), and wires (7) from stall warning horn connection studs (10).
- (3) Remove washers (11), nuts (12), and washers (13 and 14) from studs (10).
- (4) Remove stall warning horn (15) from mounting bracket (16).

B. Stall Warning Horn Installation (See Figure 401.)

- (1) Position stall warning horn (15) so that its mounting studs (10) align with holes in mounting bracket (16), and so that adjustment screw (17) aligns with access holes in mounting bracket.
- (2) Place washers (14), washers (13), and nuts (12) on studs (10).
- (3) Tighten nuts (12) per Chapter 91.
- (4) Place washers (11), wires (7), washers (9), and nuts (8) on studs (10). Tighten per Chapter 91.

3. Time Delay Controller Removal/Installation

A. Time Delay Controller Removal (Aircraft AA5-0001 through 0834, AA5A-0001 through 0054, and AA5B-0001 through 0181). (See Figure 401.)

- (1) Tag wires (18).
- (2) Remove screws (19).
- (3) Disconnect wires (18) and remove controller (20) from airplane.

B. Time Delay Controller Installation (Aircraft AA5-0001 through 0834, AA5A-0001 through 0054, and AA5B-0001 through 0181). (See Figure 401.)

- (1) Connect wires (18).
- (2) Position controller (20) so that its holes align with mounting holes.
- (3) Secure with screws (19).

AA-5 SERIES
MAINTENANCE MANUAL

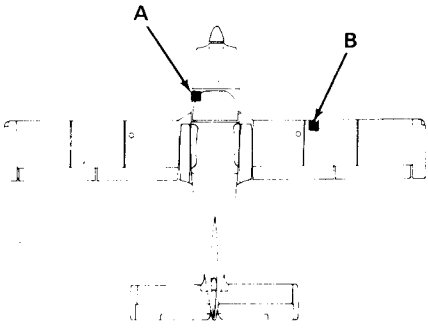

1001

AIRCRAFT TOP VIEW

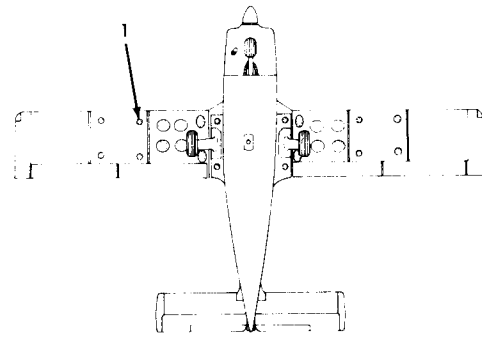

1002

AIRCRAFT BOTTOM VIEW

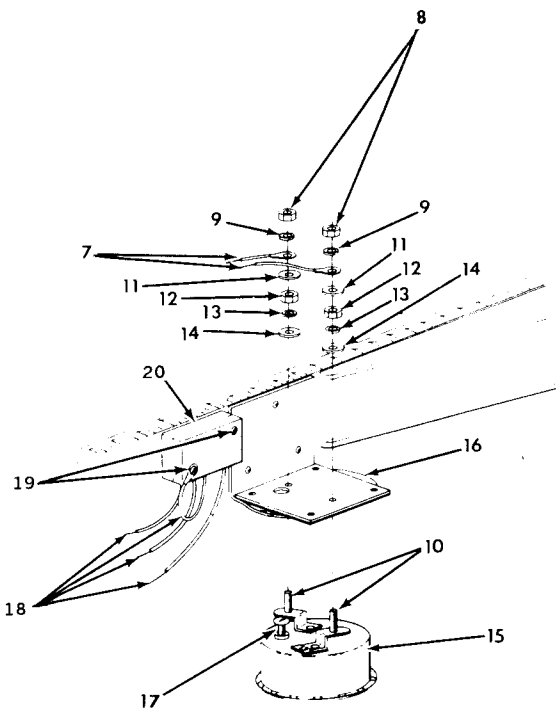

3138

DETAIL A

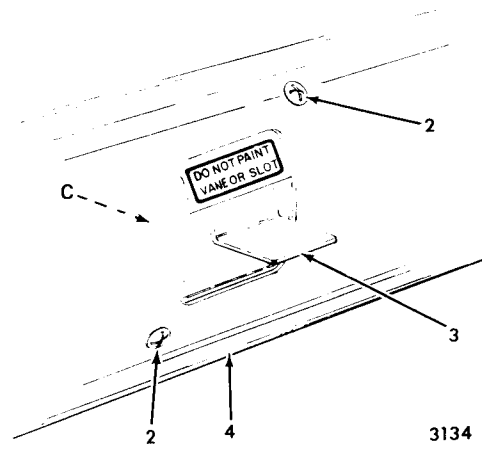

3134

DETAIL B

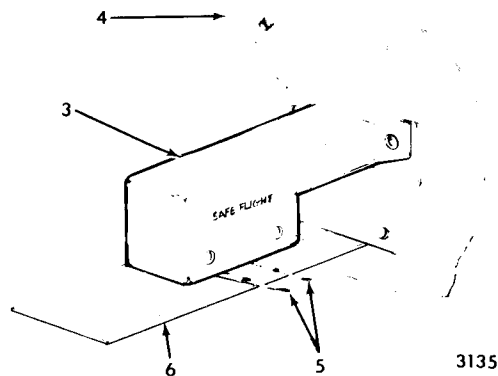

3135

DETAIL C

- | | |
|---------------------|------------------------|
| 1. Access Cover | 11. Washers |
| 2. Screws | 12. Nuts |
| 3. Sensor Switch | 13. Washers |
| 4. Wing | 14. Washers |
| 5. Wires | 15. Stall Warning Horn |
| 6. Insulating Strip | 16. Bracket |
| 7. Wires | 17. Adjustment Screw |
| 8. Nuts | 18. Wires |
| 9. Washers | 19. Screws |
| 10. Studs | 20. Controller |

Stall Warning System — Removal/Installation
Figure 401

MAINTENANCE PRACTICES – ADJUSTMENT/TEST

1. Stall Sensor Switch Adjustment/Operational Check

A. Stall Sensor Switch Adjustment (See Figure 501.)

NOTE: Adjustment of the stall sensor switch requires flight testing the airplane.

- (1) Install stall sensor switch per Removal/Installation, Paragraph 1B.
- (2) Flight test aircraft, noting speed at which stall warning system sounds, and speed at which stall occurs. Stall warning horn shall sound 4 to 9 knots (5 to 10 mph) prior to stall.
- (3) If stall warning occurs at incorrect speed, adjust switch as follows:
 - (a) Remove stall sensor switch access panel (1, Figure 401).
 - (b) Loosen screws (2) securing sensor switch.
 - (c) Reposition switch slightly, downward to decrease speed at which horn sounds, or upward to increase speed.
 - (d) Tighten screws (2) and replace access panel (1).
 - (e) Repeat Step C as necessary to obtain proper stall warning.

B. Stall Warning System Operational Check

- (1) Set MASTER switch to ON.
- (2) Lift vane on stall sensor switch. Stall warning horn shall sound within two seconds.
- (3) Release vane and set MASTER switch to OFF.

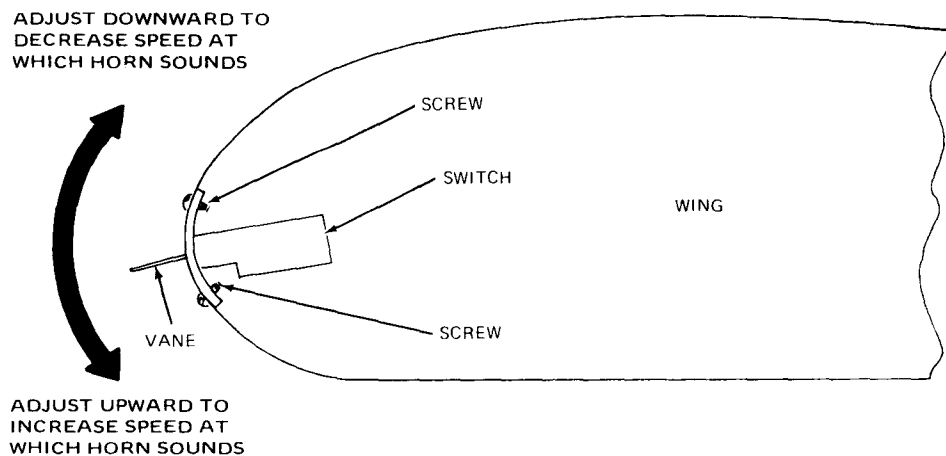

Stall Sensor Switch Adjustment
Figure 501

**AA-5 SERIES
MAINTENANCE MANUAL**

CHAPTER 28

FUEL SYSTEM

TABLE OF CONTENTS

| <u>NUMBER</u> | | <u>PAGE</u> |
|---------------|--------------------------------------|-------------|
| 28-0 | FUEL SYSTEM | |
| | Description/Operation | 1 |
| | General | 1 |
| | Troubleshooting | 101 |
| | Maintenance Practices | 201 |
| | Fuel Tank and Sump Quick Drains | 201 |
| | Refueling/Defueling | 201 |
| | Reduction of Fuel Tank Vapor Hazards | 201 |
| 28-1-1 | FUEL STORAGE SYSTEM | |
| | Description/Operation | 1 |
| | General | 1 |
| | Adjustment/Test | 501 |
| | Testing Fuel Tanks | 501 |
| | Inspection/Check | 601 |
| | Checking Fuel Tank Leaks | 601 |
| | Checking Fuel Tank Caps | 601 |
| | Checking Fuel Tank Drains | 601 |
| | Approved Repairs | 801 |
| | Integral Fuel Tank Sealants | 801 |
| | Sealing Minor Fuel Leaks | 801 |
| | Sealing Major Fuel Leaks | 805 |
| | Sealing Access Covers | 806 |
| 28-2-1 | FUEL DISTRIBUTION SYSTEM | |
| | Description/Operation | 1 |

AA-5 SERIES
MAINTENANCE MANUAL

| <u>NUMBER</u> | | <u>PAGE</u> |
|---------------|--|-------------|
| | General | 1 |
| | Maintenance Practices | 201 |
| | Servicing | 201 |
| | Fuel Selector Valve Removal/Installation | 401 |
| | Fuel Sump Tank Removal/Installation | 401 |
| | Fuel System Plumbing Removal/Installation | 403 |
| | Electric Fuel Pump Removal/Installation | 405 |
| | Fuel System Adjustments/Tests | 501 |
| | Approved Repairs | 801 |
| 28-3-1 | FUEL INDICATING SYSTEM | |
| | Description/Operation | 1 |
| | General | 1 |
| | Troubleshooting | 101 |
| | Maintenance Practices | 401 |
| | Fuel Gauge Removal/Installation | 401 |
| | Fuel Quantity Transmitter Removal/Installation | 401 |
| | Adjustment/Test | 501 |

AA-5 SERIES
MAINTENANCE MANUAL

FUEL SYSTEM - DESCRIPTION/OPERATION

1. General (See Figure 1.)

A. The fuel system consists of two fuel tanks, two sumps, two flush mounted fuel tank vents, a fuel selector valve, an engine-driven fuel pump, an auxiliary electrical fuel pump, and fuel gauges. The fuel tanks are integral parts of the wing and located outboard of the wing root. Fuel is piped to the sumps mounted in the wing roots just below the main spar. From the sumps, fuel is directed to the selector valve mounted on the upper forward console panel and then to the fuel pumps. A tee connector, mounted in the left sump to fuel selector line, provides the connection for the fuel primer line. Two fuel gauges, mounted above the fuel selector valve, are of the electrical type and are connected to fuel sending units in each tank. No gascolator or fuel drain is located in the engine compartment as the fuel system piping slopes downward to the sump drains located under the wing roots. To provide lightning strike protection, the fuel tank vents are flush mounted and maintain a slight positive pressure in flight.

B. The fuel tank capacities are as follows:

| Capacity (U.S. Gal.) | AA-5 & AA-5A (Std. Tanks) | AA-5A (Opt. Tanks) | AA-5B |
|----------------------|------------------------------|-----------------------|-------------|
| Total Capacity | | | |
| Left Tank | 19.0 | 26.3 | 26.3 |
| <u>Right Tank</u> | <u>19.0</u> | <u>26.3</u> | <u>26.3</u> |
| Total | 38.0 | 52.6 | 52.6 |
| Unusable Fuel | | | |
| Left Tank | 0.5 | 0.8 | 0.8 |
| <u>Right Tank</u> | <u>0.5</u> | <u>0.8</u> | <u>0.8</u> |
| Total | 1.0 | 1.6 | 1.6 |
| Usable Fuel | | | |
| Left Tank | 18.5 | 25.5 | 25.5 |
| <u>Right Tank</u> | <u>18.5</u> | <u>25.5</u> | <u>25.5</u> |
| Total | 37.0 | 51.0 | 51.0 |

AA-5 SERIES
MAINTENANCE MANUAL

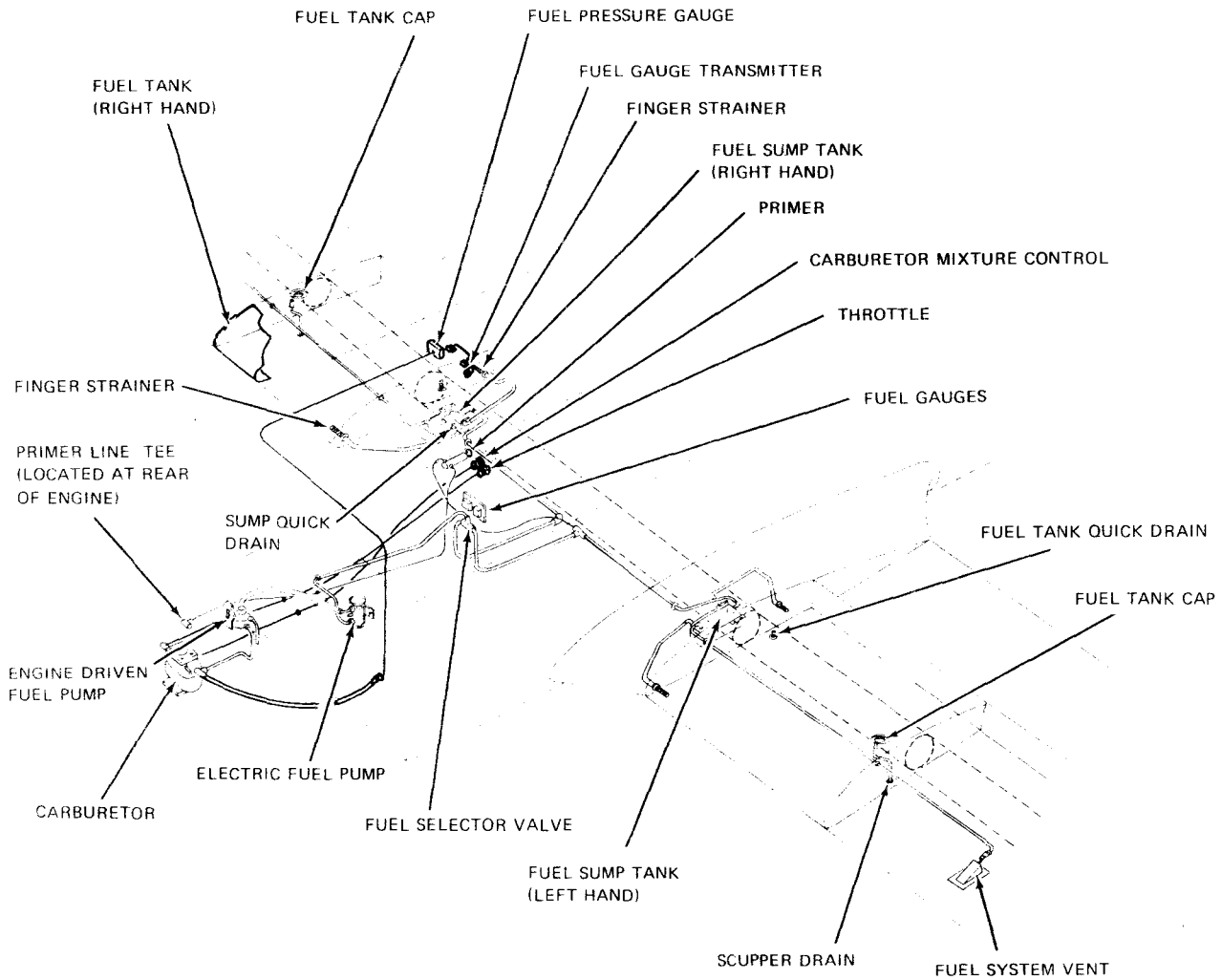

3028

Fuel System Diagram - Models AA-5 & AA-5A (Standard)
Figure 1 (Sheet 1 of 2)

AA-5 SERIES
MAINTENANCE MANUAL

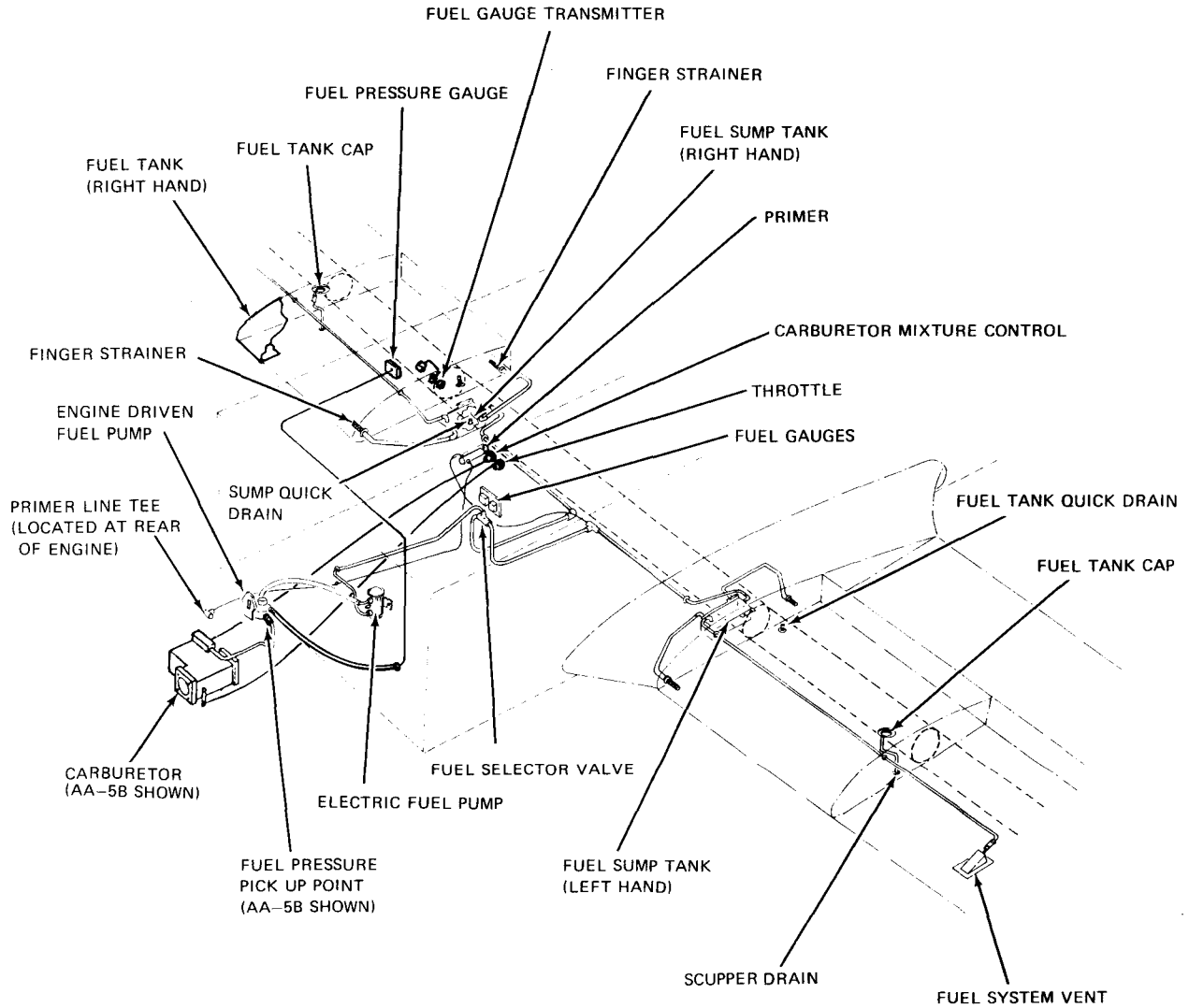

Fuel System Diagram - Models AA-5A (Option) & AA-5B
Figure 1 (Sheet 2 of 2)

AA-5 SERIES
MAINTENANCE MANUAL

- C. The electrical wiring and circuit protective devices that supply electrical power to the auxiliary fuel pump and the fuel quantity indicators is shown in Figure 2.

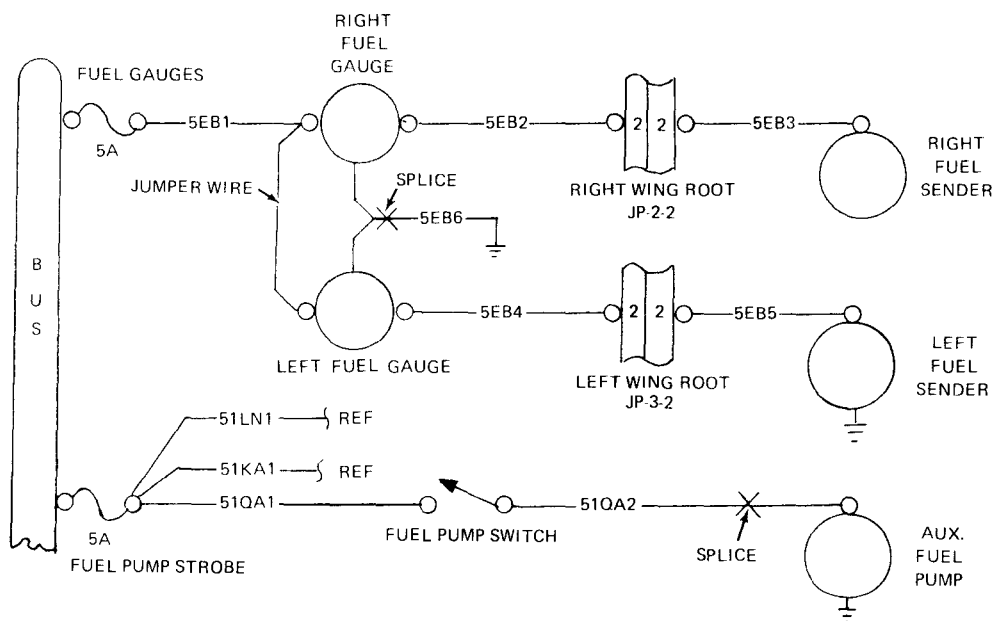

Fuel System Electrical Circuits
Figure 2

AA-5 SERIES
MAINTENANCE MANUAL

FUEL SYSTEM - TROUBLESHOOTING

1. Fuel System Troubleshooting

Troubleshoot the fuel system as follows:

| TROUBLE | PROBABLE CAUSE | REMEDY |
|---|--|---|
| No fuel pressure (electric fuel pump turned off). | Fuel tanks empty. | Service with proper grade of fuel. |
| | Defective gauge. | Replace gauge. |
| | Defective engine pump. | Remove outlet line, crank engine several times, check for fuel flow from pump. Replace if faulty. |
| | Fuel selector valve in Off position. | Switch to fullest tank. |
| | Clogged filter in electric fuel pump. | Check filter for blockage. |
| | Obstruction in fuel supply line. | Starting at carburetor, remove, inspect and clean each line. |
| | Dirty tank strainer. | Remove and clean strainer. Flush tank clean prior to re-assembly. |
| | Obstruction in pressure gauge line. | Remove all fittings and lines starting at carburetor inlet and inspect and clean as necessary. |
| No or low fuel pressure (electric fuel pump turned on). | Blown fuse. | Replace with fuse of appropriate rating. |
| | Faulty switch. | Replace switch. |
| | Defective pump. | Remove outlet line from pump. No or little flow indicates bad pump. Repair or replace pump. |
| | Partial or no fuel flow from the preceding causes. | Use the preceding remedies. |
| Low pressure or surging pressure. | Fuel valve improperly positioned. | Check position. |
| | Clogged filter in electric fuel pump. | Clean filter. |
| | Obstruction in fuel lines. | Starting at carburetor, remove, inspect, and clean all fuel lines. |
| | Fuel line or connection leaking. | Inspect all lines and tighten connections. Use thread sealant as required. |

AA-5 SERIES
MAINTENANCE MANUAL

| TROUBLE | PROBABLE CAUSE | REMEDY |
|--|--|--|
| | Leaking "O" rings in electric fuel pump. | Disassemble, inspect and replace "O" ring or pump. |
| | Defective engine pump. | Repair or replace. |
| No fuel quantity indication in both tanks. | Fuel tanks empty. | Fill with proper grade fuel. |
| | Master switch off. | Turn master switch on. |
| | Fuel gauge fuse blown. | Replace fuse in panel. |
| | Loose connections or open circuit. | Tighten connections; repair or replace wire. |
| No fuel quantity indication in one tank. | Defective gauge or transmitter. | Check per Fuel Indicating System Chapter. |
| Fuel quantity indicating too high. | Aircraft not level. | Level aircraft and recheck. |
| | Defective gauge or transmitter. | Check per Fuel Indicating System Chapter. |
| Fuel gauge indicates too low. | Aircraft not level. | Level aircraft and recheck. |
| | Defective gauge or transmitter. | Check per Fuel Indicating System Chapter. |

**AA-5 SERIES
MAINTENANCE MANUAL**

FUEL SYSTEM — MAINTENANCE PRACTICES

1. Fuel Tank and Sump Quick Drains (See Figure 201.)

Two fuel drains are provided beneath each wing, one in each wing tank and one in the fuel sump. The drains are spring-loaded to the closed position to provide a convenient method of draining small samples of fuel for preflight inspection. If fuel system drainage is required, the quick drains may be unscrewed and removed.

On Aircraft AA5-0001 through 0834, AA5A-0001 through 0522, and AA5B-0001 through 0692, the quick drains are as shown in Figure 201. The sampler cup pin is used to press the drain fitting upward allowing a sample of fuel to be taken.

On Aircraft AA5A-0523 and subsequent, and AA5B-0693 and subsequent, the quick drains are similar to those shown in Figure 201, and include a plunger attached to the fitting. The plunger is pushed upward to obtain a sample of fuel.

2. Refueling — Defueling

Refer to Chapter 12 for detailed refueling — Defueling procedures.

3. Reduction of Fuel Tank Vapor Hazards

A. General Precautions

During all defueling, ventilation, inerting or maintenance procedures involving the fuel system the following general precautions should be observed:

- (1) Defueling should be done outdoors with the aircraft at least 100 feet from hangars or other aircraft.
- (2) No smoking should be allowed within 100 feet of aircraft.
- (3) Suitable fire fighting equipment should be available. Foam or soda type extinguishing agents are recommended.

AA-5 SERIES
MAINTENANCE MANUAL

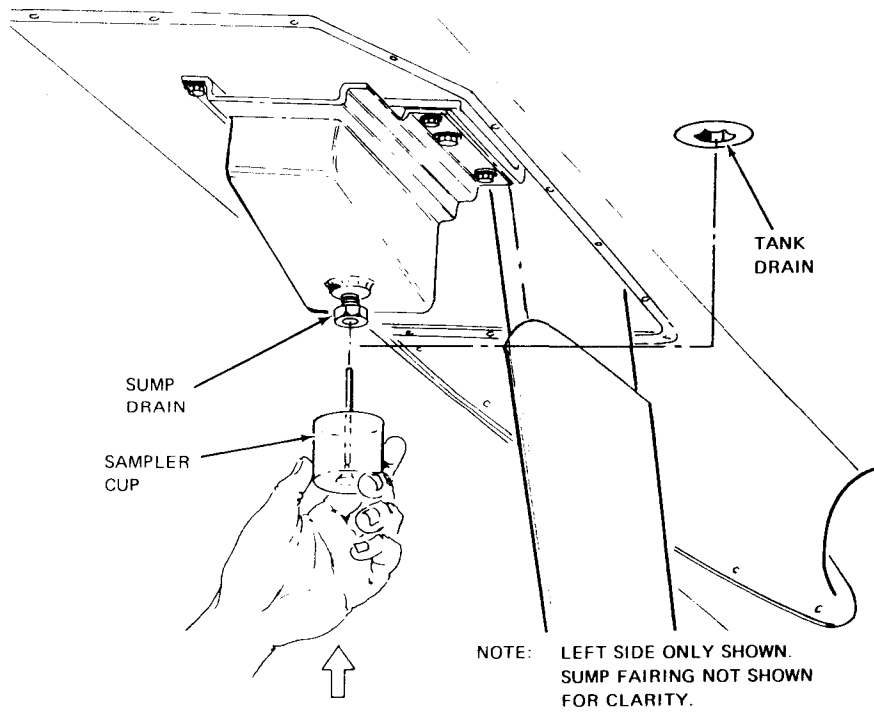
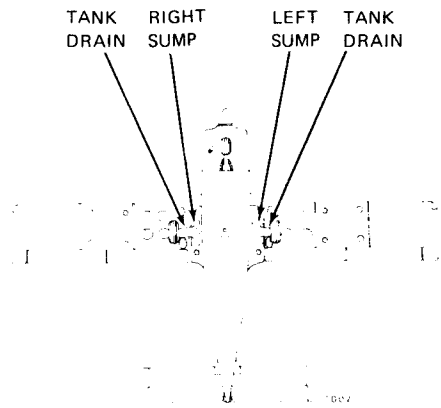

Fuel Sump and Fuel Tank Drain Operation
Figure 201

AA-5 SERIES
MAINTENANCE MANUAL

- (4) The Aircraft should be grounded to prevent static electricity from causing sparks. If a ramp ground is available it should be connected to exhaust stack. If a ramp ground is not provided, a temporary ground can be obtained by driving a metal rod into the ground and attaching a ground wire between the rod and the aircraft exhaust stack.
- (5) Flame and spark producing equipment should not be operated within 100 feet of the aircraft.
- (6) The aircraft should have its battery removed.
- (7) Only personnel working on the aircraft should be allowed in the immediate area, and no other maintenance should be performed while the tanks are being worked on.
- (8) When a fuel tank is opened for repair, air ventilation or inerting procedures should be started immediately to reduce vapor concentrations.
- (9) When draining fuel, ensure that suitable containers are available and that drained fuel is stored safely. Do not allow fuel to drip to the ground and form pools.
- (10) If it is necessary to ventilate or inert a tank when the aircraft is in a hangar, ensure that vapors do not accumulate to explosive or toxic levels in the hangar.

WARNING: WHEN FUEL IS BEING DRAINED, THERE IS LITTLE CONTROL OVER THE RELEASE OF FUEL VAPOR. THIS VAPOR SHOULD BE DISSIPATED AS QUICKLY AS POSSIBLE. COMPRESSED AIR OR EXPLOSION-PROOF BLOWERS MAY BE USED FOR THE PURPOSE.

Before working on fuel tanks, defuel them per Chapter 12. Fuel that cannot be drained by normal defueling must be removed from the tanks by opening all sump drains and access panels.

Two general methods of reducing fuel vapor hazards can be used, ventilating or inerting. The simplest method, ventilation, is done by forcing clean air through the tank until all vapors have been dissipated and flushed out by the air. This method is best when the tank access covers must be removed for work in the tank.

Inerting is another method of reducing vapor hazards. In this method an inert gas, such as nitrogen or carbon dioxide, is forced into the tank to replace the air in the tank. This reduces the oxygen in the tank to a level that will not support combustion. Although inerting may be used to prevent explosion hazards from fuel vapor, it does not prevent toxic levels of vapor in the tank.

B. Air Ventilation

- (1) Completely drain tank (or tanks) per Chapter 12.
- (2) Remove access covers and tank cap.
- (3) Use compressed air or an explosion-proof blower to blow air into the tank until tank interior is dry and free of vapor.
- (4) Continue ventilation whenever tank is open and being worked on.

NOTE: If flammable vapors from cleaning solvents are allowed in the tank, increase air circulation to dissipate them.

C. Pressure Siphoning Inerting

The following equipment, or its equivalent, is recommended for pressure siphoning inerting:

Differential pressure gauge or manometer.

Nitrogen supply with metering valve.

Rubber plug (3/8 inch O.D.) to fit fuel system vent.

- (1) Fill fuel tank to capacity, per Chapter 12.
- (2) Insert rubber plug in fuel system vent.
- (3) Set fuel selector to OFF.
- (4) On fuel line leading from sump to fuel selector, disconnect line at selector.
- (5) Connect nitrogen supply and pressure gauge (or manometer) to fitting on fuel line that was disconnected in Step (4).
- (6) Place suitable containers (totaling approximately 26 gallon capacity) under fuel sump tank.

CAUTION: WHEN PURGING TANK ENSURE THAT PRESSURE APPLIED TO TANK DOES NOT EXCEED 0.5 PSI.

- (7) Open pressure reducing valve on nitrogen bottle.
- (8) Adjust valve to maintain 0.5 psi pressure.

NOTE: A continuous supply of nitrogen at 0.5 psi must be maintained to permit siphoning and inerting of the airspace created by defueling. Do not open fuel tank drain valve.

CAUTION: WHEN FUEL SUMP TANK DRAIN IS REMOVED, FUEL WILL DRAIN RAPIDLY INTO CONTAINER. BE SURE THAT CONTAINER IS PROPERLY POSITIONED TO CATCH FUEL. KEEP ARM ABOVE DRAIN TO PREVENT FUEL FROM FLOWING ON BODY.

- (9) Remove fuel sump tank drain.
- (10) Adjust valve to maintain 0.5 psi pressure in tank until all fuel drains from tank.
- (11) If fuel tank access panels or tank cap are removed for work on tank, adjust valve to ensure that there is a continuous flow of nitrogen through the tank.

FUEL STORAGE SYSTEM — DESCRIPTION/OPERATION

1. General

Since the fuel tanks are formed by the inner wing panels, they are nonremovable. Each tank has four access panels, (See Figure 1.) two forward of the wing spar and two aft. The spar and ribs serve as baffles within the tank.

Since the Model AA-5, AA-5A, and AA-5B fuel tanks are similarly constructed, the service information in this Section is applicable to all models. Due to the increased capacity of the optional Model AA-5A and the Model AA-5B tanks, the tank area extends from the leading edge to the trailing edge of two wing bays and the inboard and outboard sides are located in 16 inches and 48 inches from the wing root. The Model AA-5 and standard Model AA-5A tanks are located in the first two inboard bays and have an aft tank bulkhead.

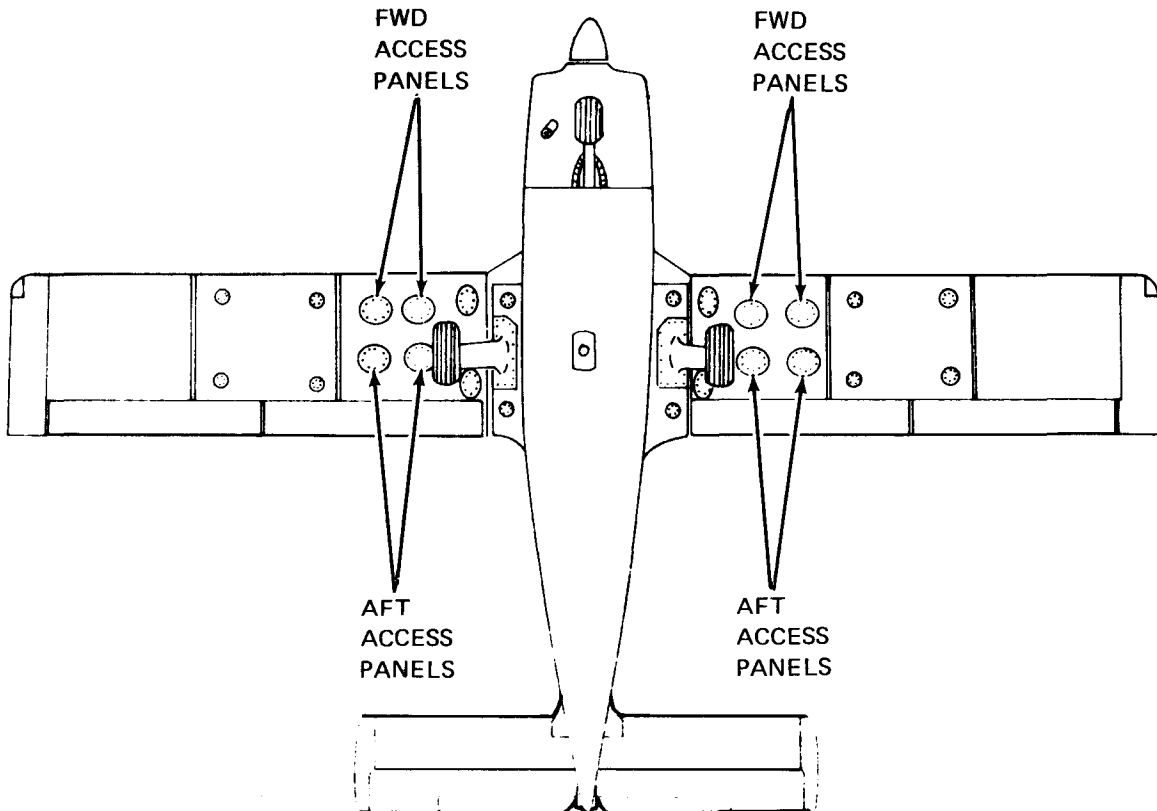

1002

Fuel Tank Access Panels
Figure 1

AA-5 SERIES
MAINTENANCE MANUAL

FUEL STORAGE SYSTEM - ADJUSTMENT/TEST

1. Testing Fuel Tanks

A. Test each fuel tank as follows:

- (1) Plug vent line at outboard end.
- (2) To the fuel line leading from the sump to the fuel selector, attach a differential pressure gauge or water manometer capable of measuring 3/4 psi or 20 in. of water.
- (3) To the fuel tank sump quick drain port, connect a well regulated supply of air or nitrogen (0.5 psi MAXIMUM or 13.8 INCHES OF WATER).
- (4) Make sure filler cap is installed.

CAUTION: DO NOT ATTEMPT TO APPLY PRESSURE TO THE TANK WITHOUT A GOOD REGULATOR AND A POSITIVE SHUTOFF IN THE SUPPLY LINE. DO NOT PRESSURIZE THE FUEL TANK TO MORE THAN 0.5 PSI OR DAMAGE MAY OCCUR.

- (5) Apply pressure slowly until 0.5 psi is obtained.
- (6) Prepare a solution of 50th% liquid dish washing detergent and 50th% water.
- (7) Apply detergent solution to outside of tank in suspect areas.
- (8) Allow 5 minutes for pressure to stabilize.
- (9) Check for presence of detergent bubbles on outside of tank to indicate location of leakage.
- (10) Turn off air supply.
- (11) If tank holds for 15 minutes, with pressure loss not exceeding .05 psi, tank is acceptable.
- (12) Reseal and retest if any leaks are found. (See Fuel Storage System - Approved Repairs for sealing procedures.)

FUEL STORAGE SYSTEM - INSPECTION/CHECK

1. Checking Fuel Tank Leaks

Fuel leaks which are not considered a flight hazard are stains, seeps, and heavy seeps NOT in an enclosed area. However, all fuel leaks should be repaired as soon as possible. Fuel leaks which are a flight hazard are running leaks in any area, and seeps, heavy seeps, or stains in an enclosed area, such as sections of the wing outboard of the fuel tank (and on AA-5 and AA-5A aircraft the area between the aft tank bulkhead and the rear wing spar). These leaks must be repaired before that tank is used for another flight. The wet or stained spot on the wing in the area of the tank is an indication of the intensity of the leak. Fuel leak classifications are shown in Figure 601.

NOTE: Stains from previously repaired leaks are not considered a flight hazard but must be inspected before each flight to insure that seepage has not begun, causing a flight hazard.

If a leak causing a flight hazard should occur at a place where there are no facilities available to make an acceptable repair, it is recommended that the leaking tank be drained and cleared of explosive vapor. By switching the fuel selector valve to the other tank the aircraft can then be flown to a facility where the fuel leak can be repaired.

2. Checking Fuel Tank Caps

The fuel caps are not vented and should be inspected at every scheduled inspection to assure the gasket inside the cap has not deformed or deteriorated. Lubricate gasket with grease (MIL-G-6032A, Chapter 12.)

3. Checking Fuel Tank Drains

The fuel tank drains should be checked at every scheduled inspection to ensure that leakage or seepage through the drain valve is not occurring. In addition, the drains should be checked for proper operation.

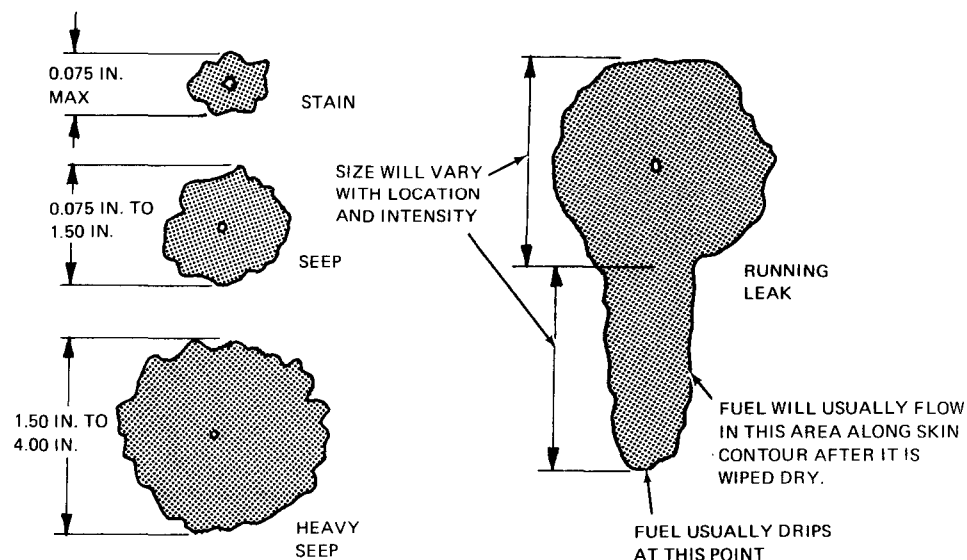

Classification of Fuel Leaks
Figure 601

**AA-5 SERIES
MAINTENANCE MANUAL**

FUEL STORAGE SYSTEM — APPROVED REPAIRS

1. Integral Fuel Tank Sealants

Fuel tank sealants are provided in Gulfstream Aerospace Service Kit No. 140. This kit contains three parts (sub kits) which may be ordered separately. These sub kits are as follows.

- A. Part 1 provides a method of repairing minor fuel leaks. The aircraft may be fueled 2 hours after application of this repair. This part contains one each Type A (quick repair) and Type C (access cover) sealant.
- B. Part 2 provides a method of repairing major fuel leaks. The aircraft may be fueled 30 hours after application of this repair. This part contains, one Type B (slow curing) and two Type C (access cover) sealant.
- C. Part 3 provides a method of sealing access covers. The aircraft may be fueled 2 hours after application of this repair. This part contains one Type C (access cover) sealant.

The following safety precautions should be observed when handling sealant materials:

Sealants have been proven to be safe materials when reasonable care is observed but the following precautions must be observed.

WARNING: SOME SEALANTS CONTAIN FLAMMABLE AND VOLATILE SOLVENTS.

KEEP SEALANTS AWAY FROM HEAT, SPARKS AND FLAME. PROPER PRECAUTIONS USED WITH FLAMMABLE MATERIAL MUST BE TAKEN WHEN APPLYING SEALANTS. COMPLY WITH ALL LOCAL SAFETY REGULATIONS.

USE AND HANDLE ONLY IN A WELL VENTILATED AREA. AIR SUPPLIED RESPIRATORS SHOULD BE USED DURING APPLICATION. AVOID REPEATED OR PROLONGED EXPOSURE. REMOVE AFFECTED PERSONNEL TO FRESH AIR IMMEDIATELY AND OBTAIN MEDICAL ATTENTION.

POLYETHYLENE MITTS AND CHEMICAL TYPE GOGGLES MUST BE USED WHEN HANDLING OR MIXING MATERIALS.

2. Sealing Minor Fuel Leaks (See Figure 801.)

- A. Prepare the aircraft for safe maintenance as follows:
 - (1) Insure Master Switch OFF.
 - (2) Aircraft grounded.
 - (3) Observe all safety precautions.
- B. Determine source of the leak. Fuel can flow along the structure of the wing, making the leak source difficult to find. A stained area is an indication of the leak source.
- C. Drain tank and/or tanks to be repaired.
- D. Gain access to tank by removing access cover. Retain hardware for reuse.
- E. With tank opened, purged and properly ventilated prepare leak area as follows:
 - (1) Remove all loose, chipped or cracked sealant from area of leak source. Use of a chisel-like tool made of hard fiber or Plexiglas, is excellent to remove old sealant.

**AA-5 SERIES
MAINTENANCE MANUAL**

- (2) Remaining sealant may then be removed with aluminum wool, 3M ELEKTRO-Cut Cloth or aluminum oxide paper. DO NOT USE STEEL WOOL OR SILICON GRIT ABRASIVES.
- (3) All cuts in old sealant should be made at 45 degrees angle to insure good adhesion between old and new sealant.
- (4) Thoroughly clean area using a vacuum cleaner or other suitable cleaning device.

NOTE: Checking and correcting for loose rivets and/or other mechanical fasteners is recommended prior to applying sealant. Check area of leak for defects in bond joints. Areas of cracked bond fillets or separated bond joints must be repaired. Contact the Gulfstream Aerospace Corporation customer service department for further information.

- (5) If inspections reveal no rework, proceed with cleaning of area to be sealed.
- (6) Using a lint-free cheese cloth that has been dampened with MEK, alcohol (99% isopropyl), or acetone, clean area until cheese cloth shows no sign of dark smudge or stain.

NOTE: If fuel tank float is in area to be sealed, wax the float to prevent it from sticking to any sealant.

F. Type A Sealant - storage, mixing and care instructions:

- (1) Storage life of sealant is at least 6 months when stored at temperatures below 80 degrees F. in the original unopened containers.
- (2) Mix sealant according to instructions on container. If weight measuring devices are not available for use, entire contents of kit can be mixed as each kit contains base compound and accelerator in proper proportions.
 - (a) Thoroughly stir the accelerator in its container until an even consistency is obtained.
 - (b) Slowly stir the accelerator into the base compound and thoroughly mix approximately 7 to 10 minutes. Be sure to scrape sides and bottom of container to include all base compound in the mixture and to assure uniform blending.
- (3) Minimum of 1/4 hour (15 minutes) application life is available at 75 degrees F. and 50% relative humidity (R.H.) Application life will vary, depending on temperature. For every 10 degrees F. rise above standard (75 degrees F. and 50% R.H.) life is reduced by half and for every 10 degrees F. below standard life is doubled. High humidity at the time of mixing shortens application life.
- (4) Cure times depend on the ambient temperatures and relative humidity. For use in this kit a minimum of 24 hours cure will be used, at standard temperature and relative humidity.
- (5) Time to pressurize - 2 hours.

G. Apply sealant to area to be sealed. Special care must be taken to joints that have a direct fuel path out of the tank area. Sealant must be pressed between these surfaces thoroughly and then fillet sealed on the fuel side. Fillet sealing is applying sealant to the edge of all joints, joggles, bend reliefs, voids, all rivets and/or fasteners through the boundary of the tank and any other place that a fuel leak has occurred.

H. Allow 2 hour minimum cure time on sealant in tank before fueling.

**AA-5 SERIES
MAINTENANCE MANUAL**

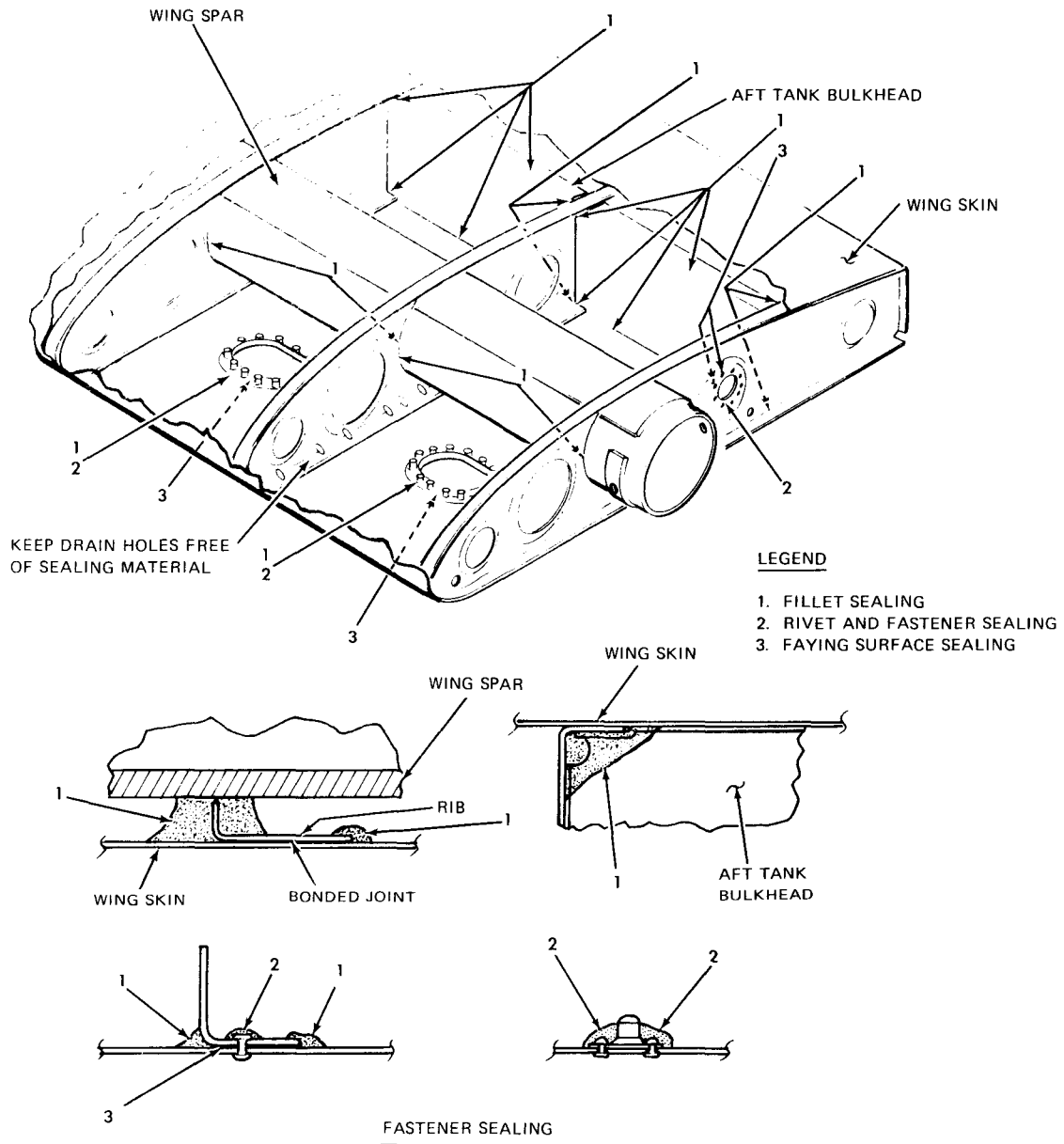

NOTE: TYPES OF SEALING SHOWN IN THIS FIGURE ARE USED WHEN MAKING A STRUCTURAL REPAIR TO THE FUEL TANK AREA AND WHEN REINSTALLING THE ACCESS COVERS.

3502

Fuel Tank Sealing - Model AA-5 & AA-5A (Standard)
Figure 801 (Sheet 1 of 2)

AA-5 SERIES
MAINTENANCE MANUAL

LEGEND

1. FILLET SEALING
2. RIVET AND FASTENER SEALING
3. FAYING SURFACE SEALING

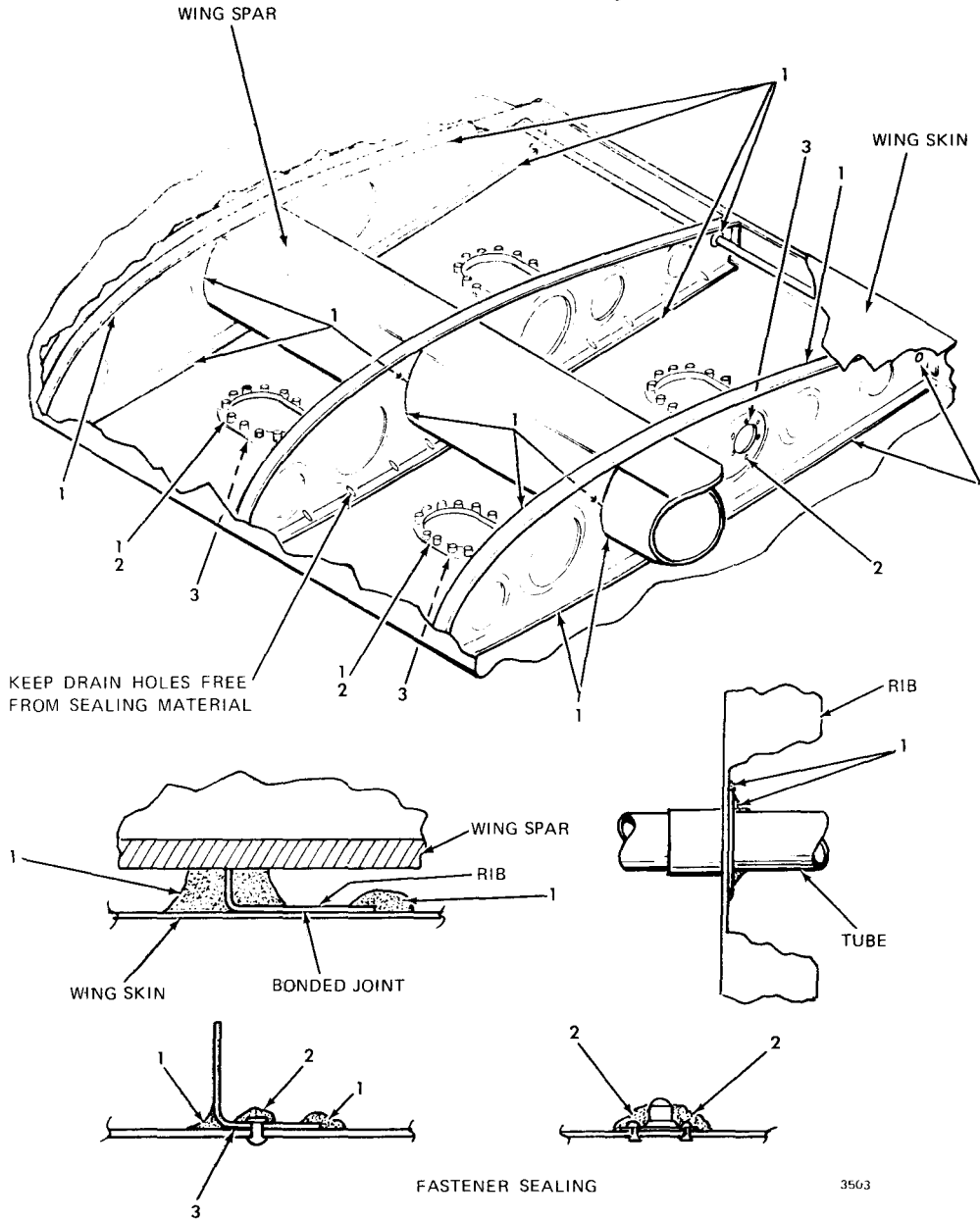

NOTE: TYPES OF SEALING SHOWN IN THIS FIGURE ARE USED WHEN MAKING A STRUCTURAL REPAIR TO THE FUEL TANK AREA AND WHEN REINSTALLING THE ACCESS COVERS.

Fuel Tank Sealing - Model AA-5A (Optional) & AA-5B
Figure 801 (Sheet 2 of 2)

**AA-5 SERIES
MAINTENANCE MANUAL**

3. Sealing Major Fuel Leaks (See Figure 801)

A. Prepare the aircraft for safe maintenance as follows:

- (1) Insure Master Switch OFF.
- (2) Aircraft grounded.
- (3) Observe all safety precautions.

B. Determine source of the leak. Fuel can flow along the structure of the wing, making the leak source difficult to find. A stained area is an indication of the leak source.

C. Drain tank and/or tanks to be repaired.

D. Gain access to tank by removing access covers. Retain hardware for reuse.

E. With tank opened, purged and properly ventilated prepare leak area as follows:

- (1) Remove all loose, chipped or cracked sealant from area of leak source. Use of a chisel-like tool, made of hard fiber or Plexiglas, is excellent to remove old sealant.
- (2) Remaining sealant may then be removed with aluminum wool, 3M ELEKTRO-Cut cloth, or aluminum oxide paper. **DO NOT USE STEEL WOOL OR SILICON GRIT ABRASIVES.**
- (3) All cuts in old sealant should be made at 45 degrees angle to insure good adhesion between old and new sealant.
- (4) Thoroughly clean area using a vacuum cleaner or other suitable cleaning device.

NOTE: Checking and correcting for loose rivets and/or other mechanical fasteners is recommended prior to applying sealant. Check area of leak for defects in bond joints. Areas of cracked bond fillets or separated bond joints must be repaired. Contact the Gulfstream Aerospace Corporation customer service department for further information.

- (5) If inspections reveal no rework, proceed with cleaning of area to be sealed.
- (6) Using a lint-free cheese cloth that has been dampened with MEK, alcohol (99% isopropyl), or acetone, clean area until cheese cloth shows no sign of dark smudge or stain.

NOTE: If fuel tank float is in area to be sealed, wax the float to prevent it from sticking to any sealant.

F. Type B Sealant - Storage, mixing and cure instructions.

- (1) Storage life of Type B sealant is at least 6 months when stored at temperatures below 80 degrees F. in the original unopened containers.
- (2) Mix sealant according to instructions on container. If weight measuring devices are not available for use, entire contents of kit can be mixed as each kit contains base compound and accelerator in proper proportions.
 - (a) Thoroughly stir the accelerator in its container until an even consistency is obtained.
 - (b) Slowly stir the accelerator into the base compound and thoroughly mix approximately 7 to 10 minutes. Be sure to scrape sides and bottom of container to include all base compound in the mixture and to assure uniform blending.

**AA-5 SERIES
MAINTENANCE MANUAL**

- (c) Minimum of 1/2 hour (30 minutes) application life is given at 75 degrees F. and 50% relative humidity (R.H.). Application life will vary, depending on temperature. For every 10 degrees F. rise above standard (75 degrees F. and 50% R.H.) life is reduced by half and for every 10 degrees F. below standard life is doubled. High humidity at the time of mixing shortens application life.
 - (d) Cure times depend on the ambient temperatures and relative humidity. For use in this kit a minimum of 45 hours cure will be used, at standard temperature and relative humidity.
 - (e) Time to pressurize - 30 hours.
 - (f) Time to fuel - 30 hours.
- G. Apply sealant to area to be sealed. Special care must be taken to joints that have a direct fuel path out of the tank area. Sealant must be pressed between these surfaces thoroughly and then fillet sealed on the fuel side. Fillet sealing is applying sealant to the edge of all joints, joggles, bend reliefs, voids, all rivets and/or fasteners through the boundary of the tank and any other place that a fuel leak has occurred.
4. **Sealing Access Covers** (See Figure 801)
- A. Prepare the aircraft for safe maintenance as follows:
 - (1) Insure Master Switch OFF.
 - (2) Aircraft grounded.
 - (3) Observe all safety precautions.
 - B. Determine source of the leak. Fuel can flow along the structure of the wing, making the leak source difficult to find. A stained area is an indication of the leak source.
 - C. Drain tank and/or tanks to be repaired.
 - D. Remove access cover or covers to be resealed. Retain hardware for reuse.
 - E. Remove all existing old sealant from access covers and mating surfaces of the tank.
 - F. Clean access covers and mating surfaces with cheese cloth dampened with MEK, alcohol (99% isopropyl) or acetone. Clean cover and surfaces until a clean cheese cloth shows no sign of dark smudge or stain.
 - G. Insure that all covers and mating surfaces are cleaned before proceeding. Pot life of sealant is only 30 minutes.
 - H. Mix Type C sealant as follows: One kit is enough for four access covers (one wing).
 - (1) Storage life of sealant is at least 6 months when stored at temperatures below 80 degrees F. in the original unopened containers.
 - (2) Mixing is 10 to 1 weight ratio. If weight measuring devices are not available for use, entire contents of kit can be mixed as each kit contains base compound and accelerator in proper proportions.
 - (a) Thoroughly stir the accelerator in its container until an even consistency is obtained.
 - (b) Slowly stir the accelerator into the base compound and mix thoroughly. Be sure to scrape sides and bottom of container to include all base compound in the mixture and to assure uniform blending.

**AA-5 SERIES
MAINTENANCE MANUAL**

- (3) Minimum of 1/2 hour (30 minutes) application life is given at 75 degrees F. and 50% relative humidity (R.H.). Application life will vary, depending on temperature. For every 10 degrees F. rise above standard (75 degrees F. and 50% (R.H.)) life is reduced by half and for every 10 degrees F. below standard life is doubled. High humidity at the time of mixing shortens application life.
 - (4) Cure times depend on the ambient temperatures and relative humidity. For use in this kit a minimum of 48 hours will be used, at standard temperature and relative humidity.
 - (5) Time to pressurize - 2 hours.
 - (6) Time to fuel - 2 hours.
- I. Apply sealant to cover in layer of 1/32 inch to 1/16 inch thick. Install cover immediately using hardware retained in Step D. Tighten screws in a staggered sequence to ensure a more even pull down of cover. Remove excess sealant that has squeezed out.
 - J. Allow 2 hours cure time after completion before pressure testing and fueling.
 - K. Repeat Paragraph 4 for all covers.
5. **Pipe Thread Repairs**
- A. The following repair technique may be used for repairing the 1/8 inch pipe threads at the quick drain valve or vent flange fittings in the AA-5 series sump tanks.
 - (1) Use a 7/16 inch drill to remove damaged threads in the flange fitting.
 - (2) Using a 1/4 inch—18 national pipe thread tap, produce new threads in the flange fitting deep enough to provide leak tight threads between the sump tank flange and the reducing bushing, when the bushing is screwed into the flange to a depth of 0.21 inch. Avoid getting chips into sump tank.
 - (3) Apply Loctite No. 262 sealant to the external threads of an AN912-1 reducer bushing and install the reducer bushing into the flange fitting. Torque the bushing to 35 - 45 inch-pounds.
 - (4) Inspect the drain valve or vent fitting to be installed. If found to be damaged, replace vent fitting or drain valve.
 - (5) Apply thread sealant to the threads of vent fitting or drain valve. Install fitting on valve and torque to 30 - 40 inch-pounds.
 - (6) Pressure test tank using 3.5 psi pressure. If fitting or valve is leaking, remove fitting or valve, add more thread sealant and reinstall with 30 to 40 inch-pounds of torque.

AA-5 SERIES
MAINTENANCE MANUAL

FUEL DISTRIBUTION SYSTEM - DESCRIPTION/OPERATION

1. General

The fuel distribution system is composed of the fuel sump tanks, the fuel selector valve, the electric fuel pump, the engine-driven fuel pump, and the plumbing associated with these components. In addition, the electrical circuitry necessary to supply operating power to the electric fuel pump is included in this system.

FUEL DISTRIBUTION SYSTEM — MAINTENANCE PRACTICES

1. Servicing

A. Electric Fuel Pump Filter

- (1) Open top left engine cowl.
- (2) Remove the bottom cover from the fuel pump by cutting the safety wire and turning the cover counter-clockwise with a 5/8 inch wrench. (See Figure 201.)
- (3) Remove the cover, gasket, magnet, and filter.

WARNING: USE SOLVENT IN A WELL VENTILATED AREA. AVOID BREATHING FUMES. KEEP AWAY FROM FLAMES.

- (4) Clean the filter by rinsing in Stoddard solvent or equivalent and blowing out cleansing agent with compressed air. If filter is distorted or damaged, it should be replaced. Refer to the Parts Catalog for replacement part number.
- (5) Reinstall filter, magnet, gasket and bottom cover.
- (6) Turn bottom cover clockwise until lugs engage, and safety wire with 0.032 wire.

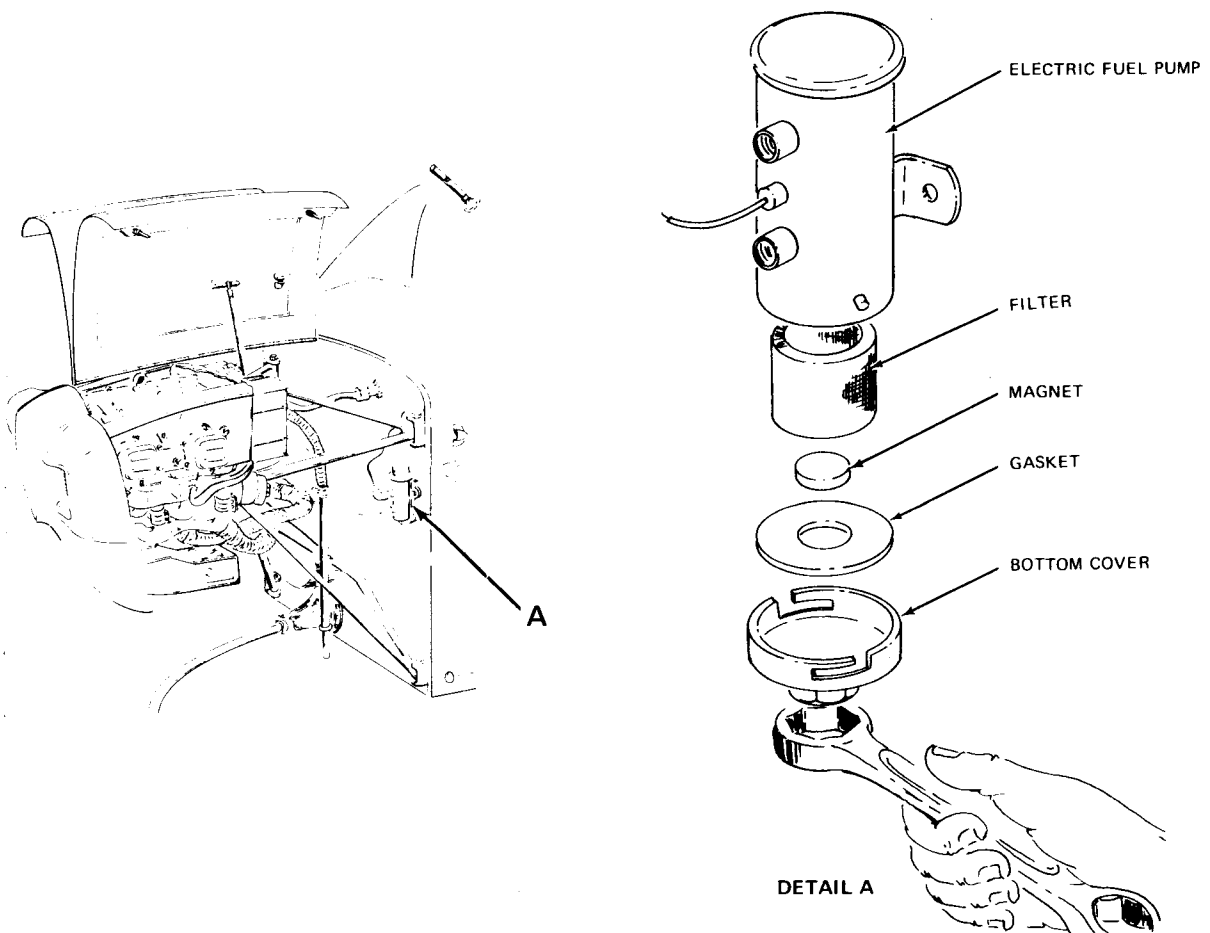

Fuel Pump Servicing
Figure 201

B. Fuel Selector Valve Lubrication (See Figure 202.)

NOTE: Fuel selector valves with wrench flats on the valve cap are designed for disassembly and service as indicated below. Valves having no wrench flats should be replaced if they are defective.

- (1) Remove fuel selector valve per Paragraph 2.
- (2) Unscrew and remove valve cap from valve body. (Leave "O" ring on valve cap unless it is damaged.)
- (3) Remove valve stem with attached dry plug cock.
- (4) Use a clean, dry, lint-free cloth to wipe all lubricant from dry plug cock and valve body. Ensure that the surfaces are clean, undamaged and free of corrosion.
- (5) Lubricate dry plug cock with a very light film of lubricant (EZ turn, by United Erie, Inc., 1429 Walnut St., Erie, Pa. 16512, or equivalent MIL-G-6032, Chapter 12.)
- (6) Insert dry plug cock in valve body and turn several times to evenly distribute lubricant. Wipe excess lubricant from valve ports and exterior of valve body. Install valve cap and tighten securely.
- (7) Install fuel selector valve per Paragraph 2.

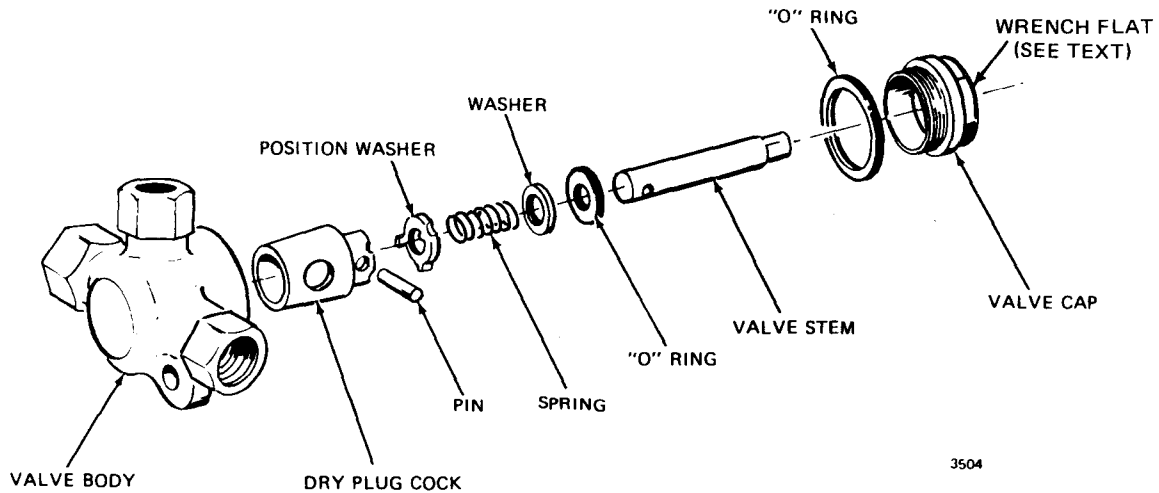

Fuel Selector Valve Disassembly
Figure 202

2. Fuel Selector Valve Removal/Installation

A. Fuel Selector Valve Removal (See Figure 401.)

- (1) Remove forward upper console panel per Chapter 25.

CAUTION: WHEN LINES ARE DISCONNECTED SOME FUEL SPILLAGE MAY OCCUR. TAKE PROPER PRECAUTIONS TO PREVENT FIRE HAZARD DUE TO SPILLAGE.

- (2) Disconnect fuel lines from three elbows (1) attached to fuel selector valve (2). Cap open lines.
- (3) Remove two nuts (3), washers (4) and bolts (5) securing fuel selector valve (2) to bracket (6).
- (4) Remove decal (7) on handle (8). Then remove the screw (9) that attaches the handle to the valve stem, and pull the handle from the valve stem.
- (5) Remove fuel selector valve (2) from bracket (6).

B. Fuel Selector Valve Installation (See Figure 401.)

- (1) Position fuel selector valve (2) in bracket (6).
- (2) Install two bolts (5), washers (4) and nuts (3) through bracket (6) and fuel selector valve (2).
- (3) Torque to 35 ± 5 inch pounds.
- (4) Install handle (8) on valve stem; secure it with the screw (9), and stick decal (7) over screw head.
- (5) Clean the exposed threads on the three elbows.
- (6) Reconnect the three fuel lines and torque to 100 ± 25 inch pounds.
- (7) Fill both fuel tanks, and set fuel selector to left tank, then to right tank while observing to ensure that no leakage occurs at connectors or valve.
- (8) Reinstall forward upper console panel, per Chapter 25.

3. Fuel Sump Tank Removal/Installation

A. Fuel Sump Tank Removal (See Figure 402.)

- (1) Remove the access panel at the wing root, per Chapter 57.
- (2) Drain the fuel tank as described in Fuel Storage System – Maintenance Practices.
- (3) Disconnect forward and aft fuel lines (1).
- (4) Disconnect vent line (2) at nipple (6). Disconnect supply line (3).
- (5) Remove bolts (4) and washers (5) attaching the sump tank to the landing gear bracket and lower the sump tank through the access opening.
- (6) Cap all open lines and fittings.

AA-5 SERIES
MAINTENANCE MANUAL

1. Elbow
2. Fuel Selector Valve
3. Nuts
4. Washers
5. Bolts
6. Bracket
7. Decal
8. Handle

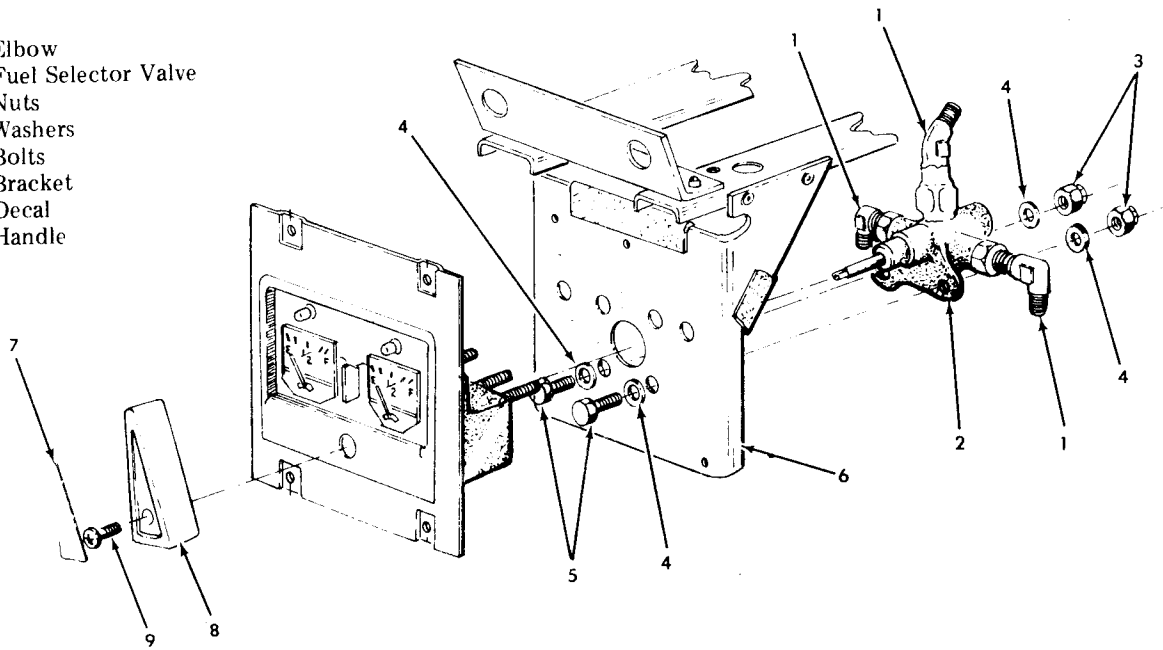

Fuel Selector Valve Removal/Installation
Figure 401

1. Fuel Line
2. Vent Line
3. Supply Line
4. Bolts
5. Washers
6. Nipple

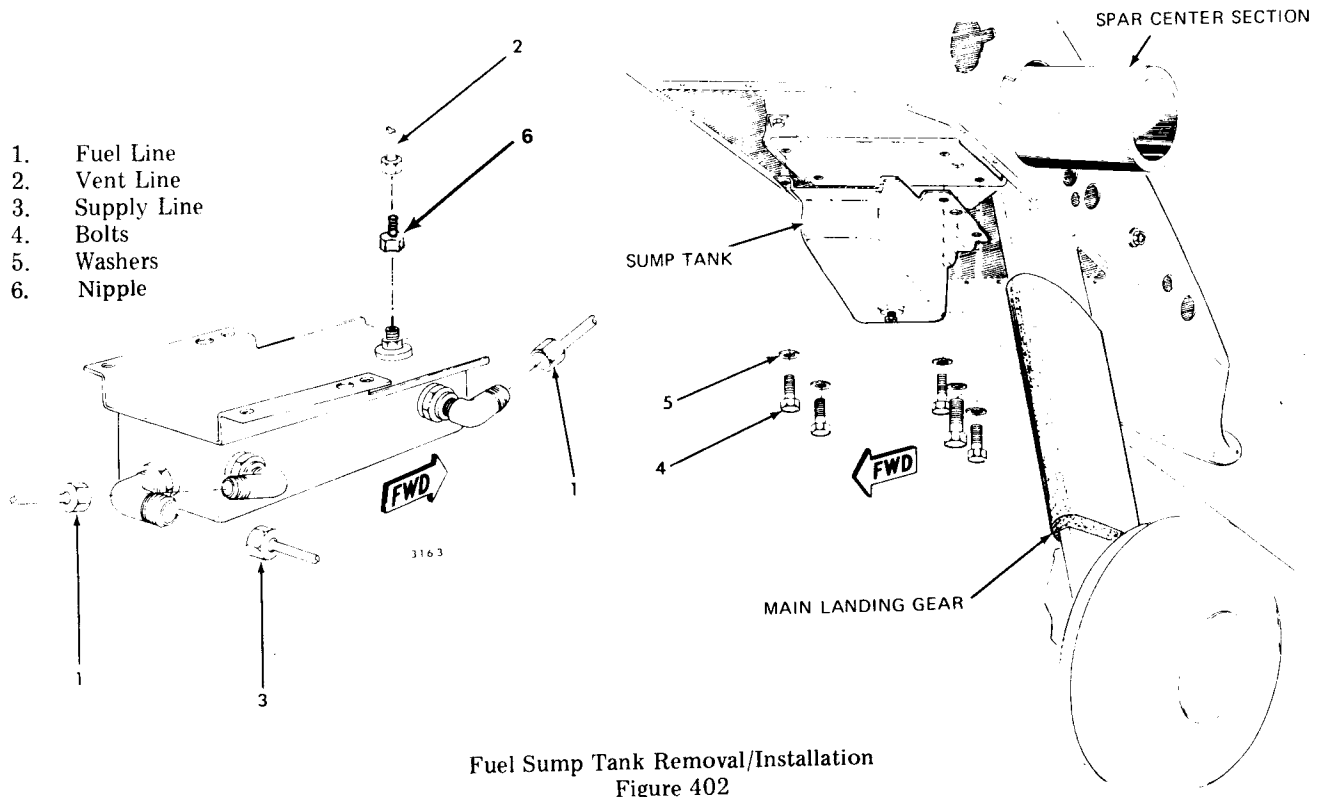

Fuel Sump Tank Removal/Installation
Figure 402

B. Fuel Sump Tank Installation (See Figure 402.)

NOTE: Loctite Pipe Sealant with Teflon (PS/T) Catalog No. 92, and High Strength Loctite, Catalog No. 262 are acceptable sealants for use on fuel system external pipe threads.

- (1) Position the sump tank on the landing gear bracket as shown in Figure 402.

CAUTION: WHEN MOUNTING THE SUMP TANK, BE SURE THAT THE PROPER MOUNTING BOLTS (AN3-3A) ARE USED. BOLTS THAT ARE TOO LONG MAY EXTEND THROUGH THE LANDING GEAR MOUNT AND SCRATCH OR GOUGE THE CENTER SPAR.

- (2) Using the bolts and washers, secure the sump tank to the landing gear mount. Torque bolts per Chapter 91.
- (3) Remove caps from lines and fittings capped in Step 3A (6).
- (4) Use a bristle brush to clean threads of fuel lines disconnected.
- (5) Reconnect the lines disconnected in Steps 3A (3 and 4).
- (6) Torque the forward and aft fuel lines to 200 ± 50 inch pounds.
- (7) Torque the vent line to 52.5 ± 12.5 inch pounds.
- (8) Put fuel in tank per Chapter 12 and check fittings for leakage.
- (9) Reinstall wing root access panel per Chapter 57.

4. Fuel System Plumbing Removal/Installation

A. Fuel System Plumbing Removal

WARNING: WHEN DISCONNECTING FUEL LINES FROM THE MAIN FUEL TANK, HOLD THE BULKHEAD FITTING WITH A WRENCH TO PREVENT IT FROM TURNING AND BREAKING THE SEAL.

CAP ALL OPEN LINES AND FITTINGS TO PREVENT CONTAMINATION FROM ENTERING SYSTEM.

WHEN DISCONNECTING LINES, FIRST ENSURE THAT ALL RESIDUAL FUEL IS DRAINED FROM THE LINE.

EXERCISE THE PRECAUTIONS PREVIOUSLY MENTIONED TO MINIMIZE FIRE HAZARDS.

Since the fuel system plumbing is composed of standard aircraft tubing and fittings, its removal is merely the use of standard maintenance practices.

B. Fuel System Plumbing Installation

CAUTION: PRIOR TO INSTALLATION, ALL FUEL LINES AND FITTINGS SHOULD BE CLEANED INTERNALLY BY PASSING STODDARD SOLVENT THROUGH THEM, THEN AIR DRYING TO PREVENT CONTAMINATION FROM BEING INTRODUCED INTO THE SYSTEM.

ALL THREADED FITTINGS SHOULD BE CLEANED WITH A STIFF BRISTLE BRUSH BEFORE THE FITTING IS INSTALLED.

THREADED FITTINGS SHOULD BE TORQUED IN ACCORDANCE WITH FIGURE 403.

Like removal, the installation of fuel system plumbing follows standard maintenance practices.

AA-5 SERIES
MAINTENANCE MANUAL

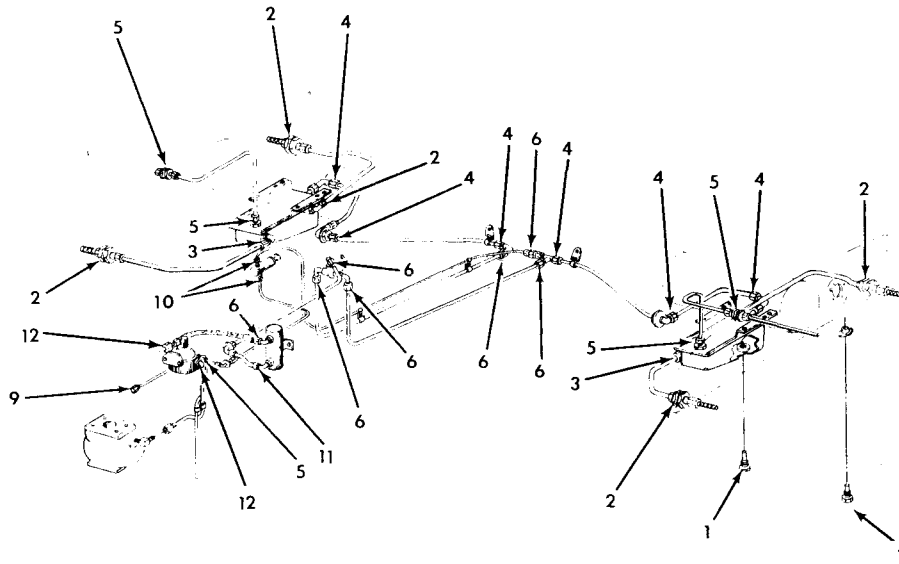

| <u>PART NO.</u> | <u>NAME</u> | <u>INDEX</u> | <u>TORQUE VALUE</u> |
|-----------------|-------------|--------------|---------------------|
| F391-53S | Drain Valve | 1 | 25 ± 5 In. lb |
| AN818-8D | Nut | 2 | 200 ± 50 In. lb |
| AN924-8D | Nut | 3 | 200 ± 50 In. lb |
| AN924-6D | Nut | 4 | 100 ± 25 In. lb |
| AN818-4D | Nut | 5 | 52.5 ± 12.5 In. lb |
| AN818-6D | Nut | 6 | 100 ± 25 In. lb |
| AN818-2D | Nut | 7 | 25 ± 5 In. lb |
| AN924-2D | Nut | 8 | 25 ± 5 In. lb |
| AN818-2 | Nut | 9 | 25 ± 5 In. lb |
| AN805-2 | Nut | 10 | 25 ± 5 In. lb |
| AN818-6 | Nut | 11 | 120 ± 30 In. lb |
| AN924-6 | Nut | 12 | 120 ± 30 In. lb |

Fuel System Fitting Torque Values
Figure 403

5. Electric Fuel Pump Removal/Installation

A. Electric Fuel Pump Removal (See Figure 404.)

- (1) Disconnect electrical pigtail connector at splice clip (1).
- (2) Disconnect the two fuel lines (2) from the pump (3) and cap fittings.
- (3) Remove the nuts (4) and washers (5) securing the pump (3) to the firewall and remove the pump.

B. Electric Fuel Pump Installation (See Figure 404.)

- (1) Position fuel pump on firewall as shown in Figure 404.
- (2) Install washers (5) and nuts (4).
- (3) Torque to 35 ± 5 inch pounds.
- (4) Clean exposed threads on fuel pump elbow fittings with a stiff bristle brush.
- (5) Torque fittings per Figure 403.
- (6) Reconnect electrical pigtail to wire and crimp connector (1).

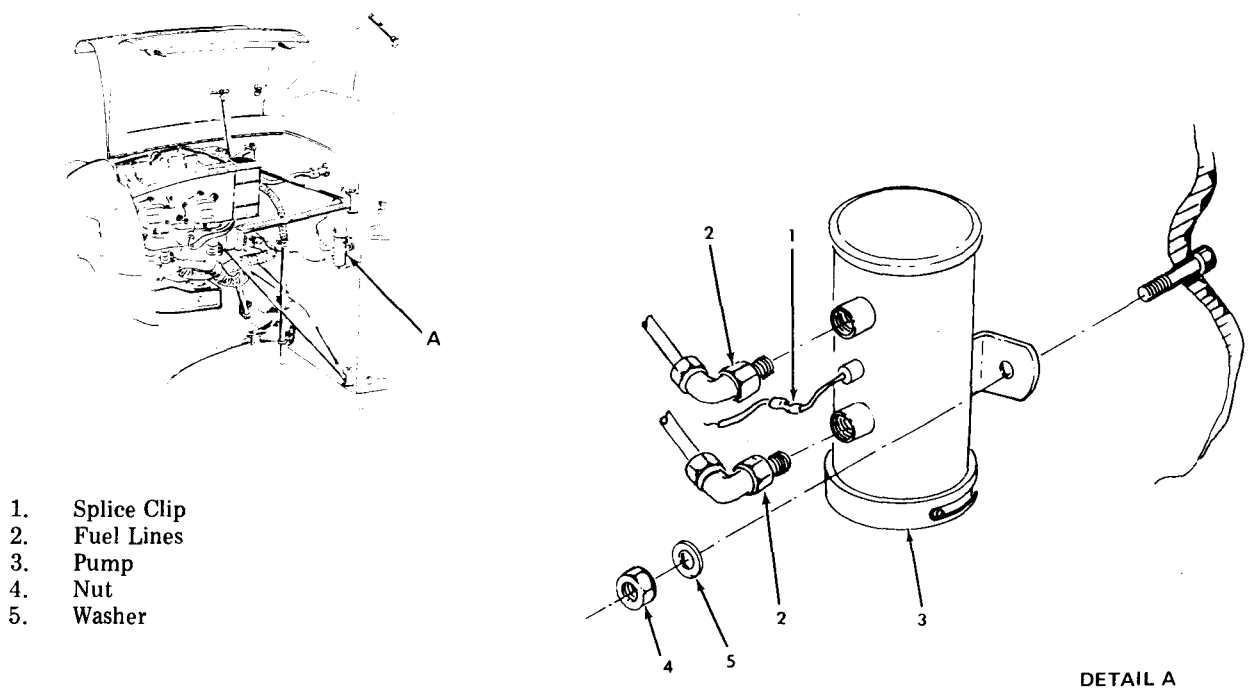

Electric Fuel Pump Removal/Installation
Figure 404

6. Fuel System Adjustments/Tests

A. Fuel Sump Tank Pressure Test

- (1) Remove fuel sump tank as described in Paragraph 3.
- (2) Plug all fuel line fittings on the sump tank.
- (3) To the vent line fitting, attach a well regulated supply of air or nitrogen capable of supplying 3.5 psi pressure.

CAUTION: DO NOT ATTEMPT TO APPLY PRESSURE TO THE TANK WITHOUT A GOOD REGULATOR AND A POSITIVE SHUTOFF IN THE SUPPLY LINE. DO NOT PRESSURIZE THE SUMP TANK TO MORE THAN 3.5 PSI OR DAMAGE MAY OCCUR.

- (4) Apply pressure slowly until 3.5 psi is obtained.
- (5) Prepare a solution of 50% liquid diswashing detergent and 50% water.
- (6) Apply solution to outer surface of tank.
- (7) Check for presence of bubbles to indicate location of leakage.
- (8) If sump tank holds pressure for 15 minutes with pressure loss not exceeding 0.05 psi, tank is acceptable.
- (9) If leaks are found, reseal and retest. (Fuel Storage System — Approved Repairs for sealing procedures.)

B. Fuel System Plumbing Pressure Test

- (1) Pressurize the fuel system plumbing by performing the procedures in Fuel Storage System — Inspection/Check.
- (2) Prepare a solution of 50% liquid diswashing detergent and 50% water.
- (3) Apply solution to plumbing at all locations of suspected leakage.
- (4) Check for presence of bubbles to indicate location of leakage.
- (5) If plumbing holds pressure for 15 minutes with pressure loss not exceeding 0.05 psi, plumbing is acceptable.
- (6) If leaks are found, repair per Fuel Storage System — Approved Repairs.

C. Electric Fuel Pump Operational Check

- (1) Ensure that one fuel tank contains at least 3 gallons of fuel.
- (2) Set FUEL SELECTOR valve to the tank containing fuel.
- (3) Set MASTER SWITCH to ON.
- (4) Set AUX. FUEL PUMP switch to ON.
- (5) Observe FUEL PRESSURE gauge. Gauge must indicate 0.5 to 8.0 psi.
- (6) Set AUX. FUEL PUMP and MASTER switches to OFF.

**AA-5 SERIES
MAINTENANCE MANUAL**

D. Engine-Driven Fuel Pump Operational Check

NOTE: It is necessary to operate the aircraft engine in order to check the engine-driven fuel pump.

- (1) Ensure that one fuel tank contains at least 3 gallons of fuel.
- (2) Set MIXTURE to FULL RICH.
- (3) Set FUEL SELECTOR valve to the tank containing fuel.
- (4) Set MASTER SWITCH to ON.
- (5) Set AUX. FUEL PUMP switch to ON.
- (6) Observe FUEL PRESSURE gauge. Gauge shall indicate 0.5 to 8.0 psi.
- (7) If required, prime engine.

WARNING: ENSURE THAT PROPELLER IS CLEAR PRIOR TO STARTING ENGINE.

- (8) Set MAGNETO switch to LEFT.
- (9) Press STARTER button until engine starts.
- (10) Set MAGNETO switch to BOTH.
- (11) Check OIL PRESSURE gauge. Oil pressure shall be indicated within 30 seconds.
- (12) Set AUX. FUEL PUMP switch to OFF while observing FUEL PRESSURE GAUGE. Gauge shall indicate 0.5 to 8.0 psi, with auxiliary fuel pump off.
- (13) Run engine at several different power settings and ensure that fuel pressure remains between 0.5 and 8.0 psi.
- (14) Idle engine and set MIXTURE to IDLE CUTOFF.
- (15) Set MAGNETO switch to OFF.
- (16) Set MASTER SWITCH to OFF.

7. Approved Repairs

A. Fuel Sump Tank Sealing

- (1) Remove sump tank as described in Paragraph 3.
- (2) Pressure test sump tank as described in Paragraph 6.

NOTE: Prior to removing sump tank fittings, note their position (the angles at which the elbows are installed) so that they can be similarly positioned when reinstalled.

- (3) Remove fuel line and vent line fittings from sump tank.

WARNING: USE SOLVENT IN A WELL VENTILATED AREA. AVOID BREATHING FUMES.
KEEP AWAY FROM FLAMES.

- (4) Wash inside of sump tank thoroughly with Stoddard solvent (or equivalent) until no residue washes from tank.
- (5) Leave fitting openings open and allow tank to thoroughly air-dry.
- (6) Plug or tape all fitting openings except the sump tank drain plug opening. (See Figure 401.)
- (7) Pour approximately 4 ounces of Randolph Products Co. No. 802 slosh coating (or equivalent) into the drain plug opening in the sump tank.
- (8) Plug or tape the drain plug opening.
- (9) Rotate and shake the sump tank such that the coating entirely coats its interior.
- (10) Remove the plug or tape from the drain plug opening and allow excess coating to pour from sump tank.
- (11) Remove plugs or tape from all sump tank fitting holes and position sump tank so that excess coating will drain from sump tank.
- (12) Leave sump tank in this position and allow to air-dry for 24 hours.
- (13) When tank coating is thoroughly dry, scrape excess coating from threaded fitting holes. Hold tank with threaded holes down while scraping coating to ensure that flakes of coating removed do not fall into the tank.
- (14) Apply Parker Sealube (or equivalent) to fuel and vent line fittings and install fittings.
- (15) Pressure test sump tank in accordance with Paragraph 6.
- (16) If sump tank is acceptable per Paragraph 6 test, install it on aircraft per Paragraph 3.

FUEL INDICATING SYSTEM - DESCRIPTION/OPERATION

1. General

The fuel indicating system is composed of two fuel quantity transmitters (one in the inboard end of each fuel tank), two electrically operated fuel gauges (one for each tank) and the wiring necessary to connect the elements of the system.

As is shown in Figure 1, the fuel indicating system receives power from the aircraft electrical system. (Since both systems are identical only the right is shown.) This power is routed through a rheostat (variable resistance) element in the fuel quantity transmitter. A float in the fuel tank positions the wiper of the rheostat such that its resistance varies directly with fuel quantity. This, in turn, varies the amount of current applied to the fuel gauge. Since the fuel gauge is simply an electrical meter movement, its needle deflection is directly proportional to the amount of power applied. Thus the fuel gauge deflection indicates the fuel quantity represented by the position of the fuel transmitter float.

NOTE: Fuel quantity indicated by the gauge will be accurate only when the aircraft is in a level attitude.

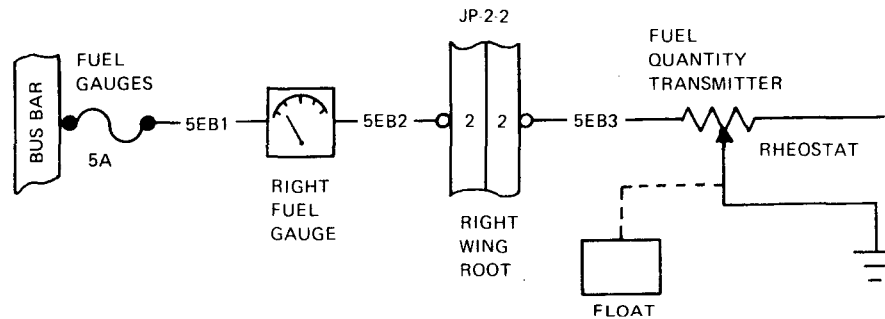

3505

Fuel Indicating System - Schematic
Figure 1

AA-5 SERIES
MAINTENANCE MANUAL

FUEL INDICATING SYSTEM - TROUBLESHOOTING

1. Fuel Indicating System Troubleshooting

| TROUBLE | PROBABLE CAUSE | REMEDY |
|---------------------------------------|--|---|
| Fuel gauge fails to indicate | Defective transmitter. | Replace transmitter |
| | Transmitter not grounded. | Check transmitter ground connections. |
| | Loose or damaged wiring. | Check wiring for damage and secure connections. |
| | Defective fuel gauge. | Replace gauge. |
| Fuel gauge does not indicate properly | Defective transmitter. | Replace transmitter. |
| | Transmitter float improperly adjusted. | Adjust transmitter float level. |
| | Defective fuel gauge. | Replace gauge. |

MAINTENANCE PRACTICES – REMOVAL/INSTALLATION

1. Fuel Gauge Removal/Installation

A. Fuel Gauge Removal (See Figure 401.)

- (1) Ensure that MASTER SWITCH is set to OFF.
- (2) Remove fuel selector handle decal (1) and attaching screw (2) and pull handle (3) from valve stem (4).
- (3) Pull insulator boots (5) up on wires to expose terminals of gauges.

NOTE: When wires are disconnected, tag them for identification to assist in reassembly.

- (4) Remove nuts (6), washers (7 and 8), and wire lugs (9) from gauge terminal studs (10).
- (5) Remove nuts (11) and insulators (12) from terminal studs (10).
- (6) Remove nut (13), washer (14), and grounding screw (15). Pull screw (15) from ground lugs (16).
- (7) Pull gauge wiring from grommet (17).
- (8) Remove screws (18) at top and bottom of royalite panel (19) on fuel selector console.
- (9) Rotate panel (19) up to remove it.
- (10) Cut the gauge ground wire (21) between the panel (19) and the ground lug (16).
- (11) Remove the gauge (20) from the panel (19).

B. Fuel Gauge Installation (See Figure 401.)

- (1) Slide the end of the gauge ground wire (21) through the access opening (22) in the panel (19).
- (2) Attach end of ground wire (21) to ground lug (16).
- (3) Position gauge (20) in panel (19).
- (4) Use screw (15), washer (14), and nut (13) to secure ground lugs (16) to bracket (23).
- (5) Ensure that insulation (24) on selector valve is not damaged.
- (6) Position panel (19) on bracket (23) and install insulators (12) and nuts (11) on gauge terminal studs (10).
- (7) Route wiring through boot (5) and install wire lugs (9) on terminal studs (10). Secure with washers (8 and 7) and nuts (6).
- (8) Slide boots (5) over terminals to insulate connection.
- (9) Install handle (3) on valve item (4) and secure with screw (2). Install decal (1).

2. Fuel Quantity Transmitter Removal/Installation

A. Fuel Quantity Transmitter Removal

- (1) Drain fuel tank as described in Chapter 12.
- (2) On Model AA-5 and AA-5A (standard) aircraft, remove wing root access panel and disconnect lead from fuel transmitter. If early AA-5, note if transmitter is removable from inside or outside the wing tank. Transmitters on AA5-0085 and earlier aircraft are removable only from inside the tank, through the inner aft fuel tank access hole, while on AA5-0086 and later aircraft they are removable from outside the tank through the wing root access panel.

AA-5 SERIES
MAINTENANCE MANUAL

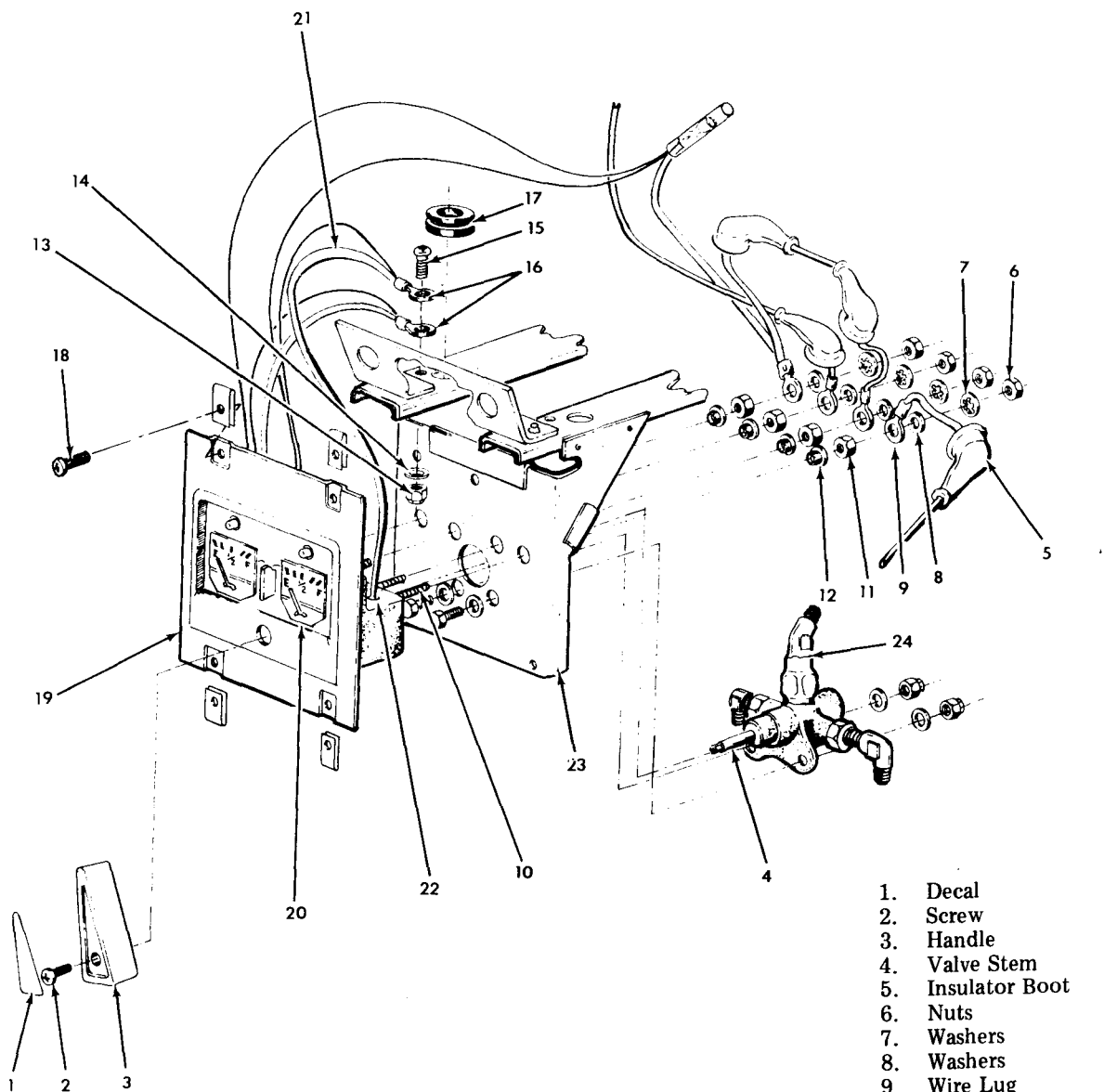

1. Decal
2. Screw
3. Handle
4. Valve Stem
5. Insulator Boot
6. Nuts
7. Washers
8. Washers
9. Wire Lug
10. Terminal Stud
11. Nuts
12. Insulator
13. Nut
14. Washer
15. Grounding Screw
16. Ground Lug
17. Grommet
18. Screws
19. Panel
20. Gauge
21. Ground Wire
22. Access Opening
23. Bracket
24. Insulation

Fuel Gauge Removal/Installation
Figure 401

On Model AA-5A (Optional) and AA-5B aircraft, remove the inboard aft wing inspection cover and disconnect lead from fuel transmitter. The transmitter is removable from outside the tank.

On AA5-0085 and earlier aircraft, remove inner aft fuel tank access panel from under the wing.

NOTE: When removing transmitter ensure that no dislodged sealant chips remain in tank.

- (3) Remove the screws attaching the fuel transmitter to the inboard end of fuel tank. Remove transmitter.

B. Fuel Quantity Transmitter Installation

- (1) Inspect the fuel quantity transmitter gasket to ensure that it is clean and undamaged. If it is damaged or deformed, replace it.

WARNING: USE SOLVENTS IN A WELL VENTILATED AREA. AVOID BREATHING FUMES. KEEP AWAY FROM FLAMES.

- (2) On early AA-5 aircraft, remove sealant from inner aft fuel tank cover mating surface and clean with trichloroethane.
- (3) Position fuel quantity transmitter, with gasket, in tank and secure with attaching screws.
- (4) Attach electrical leads to transmitter and torque attaching screws to 15 inch pounds (do not over torque).
- (5) On early AA-5 aircraft, apply a coating of Sealant Churchill Chemical Corp., (3C-200 Class B-1/2, or equivalent) to inner aft fuel tank cover mating surface.
- (6) On early AA-5 aircraft, install fuel tank cover and secure with screws, per Figure 402.
- (7) On AA-5 and AA-5A (standard) aircraft, install wing root access panel, and secure with screws, per Figure 402.

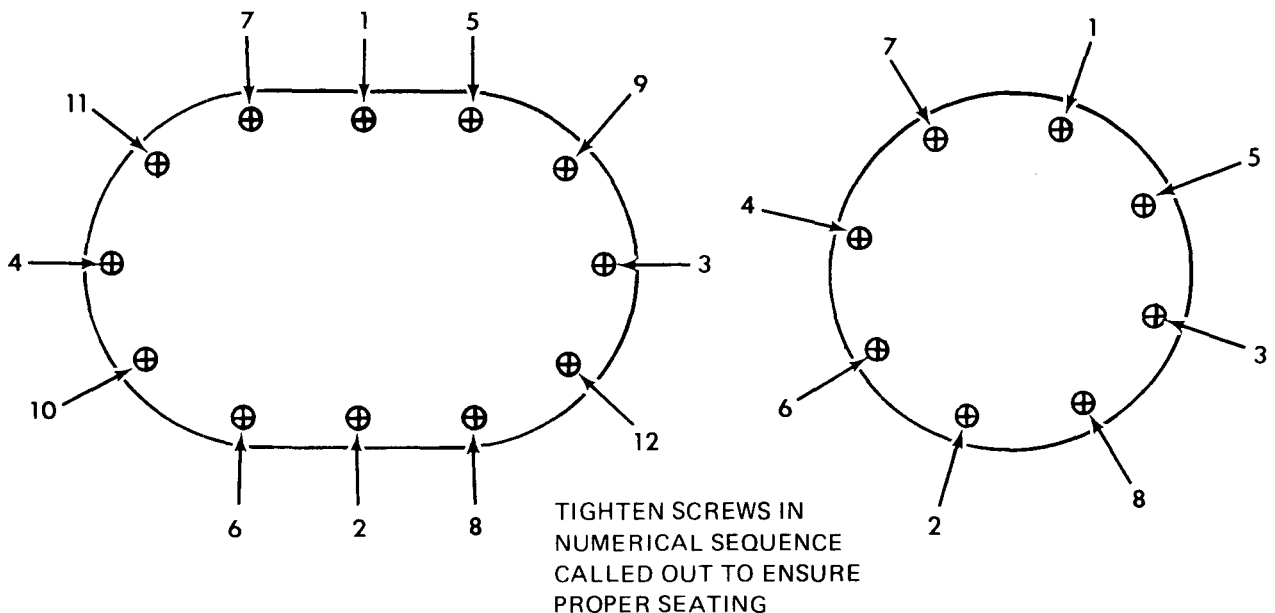

Access Panel Installation
Figure 402

3. Fuel Gauge Adjustment/Test

A. Fuel Gauge Calibration

- (1) Remove the fuel gauge from the aircraft as described in Paragraph 1.
- (2) Connect the fuel gauge to the test setup shown in Figure 501.

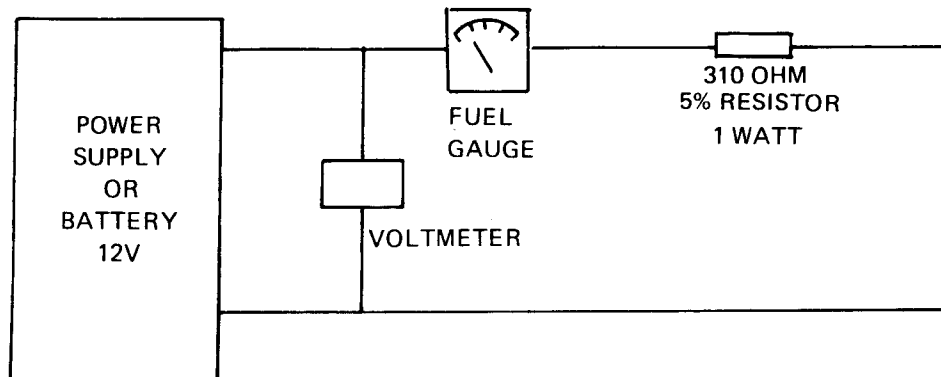

Fuel Gauge Calibration Setup
Figure 501

- (3) Adjust the power supply (if used) for a 12.6 ± 1 volt indication on the voltmeter. If a battery is used, ensure that the voltage is 12.6 ± 1 volt.
- (4) Check fuel gauge indication. Gauge shall indicate at or below the empty mark with no portion of the needle above the mark. The needle shall not indicate more than one needle width below the empty mark.

CAUTION: IF THE GAUGE INDICATION IS NOT WITHIN TOLERANCE, DO NOT ATTEMPT TO REPAIR THE GAUGE. REPLACE IT.

- (5) Remove power from the test setup (Figure 501) and replace the 310 ohm resistor with a 24 ohm, 1 watt, 5% resistor.
- (6) Check that voltmeter indicates 12.6 ± 1 volt.
- (7) Check fuel gauge indication. Gauge shall indicate within one needle width of the full mark. If not, replace the gauge.

CAUTION: IF THE GAUGE INDICATION IS NOT WITHIN TOLERANCE, DO NOT ATTEMPT TO REPAIR THE GAUGE. REPLACE IT.

B. Fuel Quantity Transmitter Calibration

WARNING: BE EXTREMELY CAUTIOUS WHEN WORKING WITH ELECTRICAL COMPONENTS AROUND THE FUEL SYSTEM. ELECTRICAL SPARKS AROUND A FUEL TANK CONTAINING FUEL VAPOR ARE EXTREMELY HAZARDOUS.

Fuel tank transmitters can be calibrated either in or out of the fuel tank. Calibration in the tank requires draining the tank completely for the empty position, filling to 1/2 capacity for 1/2 fuel position and completely filling for the full position. The aircraft must be level for all transmitter calibration. The transmitter can be calibrated outside the tank by positioning the float in the empty, 1/2, and full positions as shown in Figure 502. The transmitter mounting flange must be grounded to the aircraft for all calibration done outside of the tank.

AA-5 SERIES
MAINTENANCE MANUAL

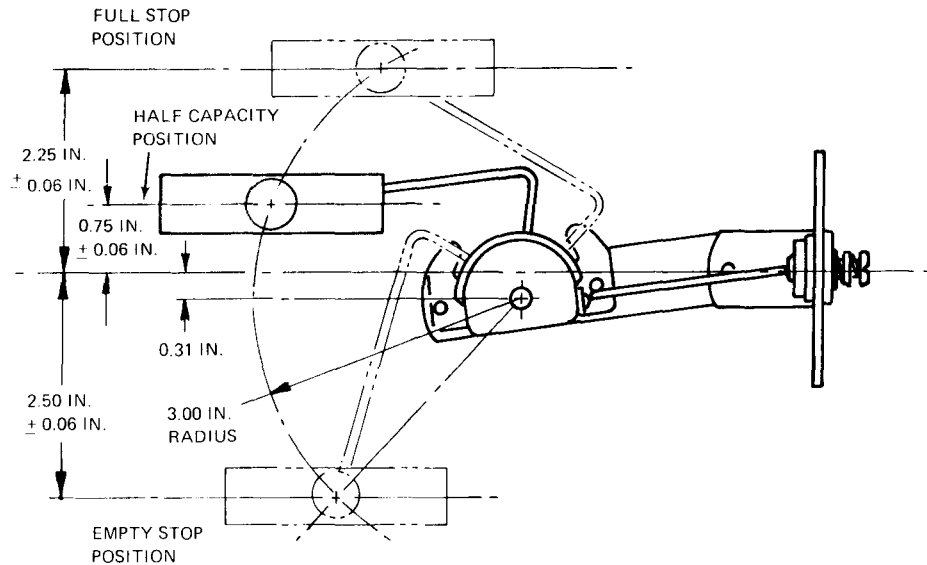

3507

Fuel Transmitter Calibration
Figure 502

All calibrations should be performed using the aircraft fuel gauges. No part of the fuel gauge needle should show above the empty mark with the transmitter in the empty position. Small adjustments to the transmitter can be made by bending the stops or the float arm. If small adjustments do not correct the problem, the transmitter and/or the gauge must be replaced.

CHAPTER 30
ICE AND RAIN PROTECTION

TABLE OF CONTENTS

| <u>NUMBER</u> | | <u>PAGE</u> |
|---------------|---|-------------|
| 30-0 | ICE AND RAIN PROTECTION | |
| | Description/Operation | 1 |
| | General | 1 |
| 30-1-1 | CARBURETOR HEAT SYSTEM | |
| | Description/Operation | 1 |
| | General | 1 |
| | Major Components and Their Location | 1 |
| | Maintenance Practices | 201 |
| | Operational Test | 201 |
| 30-1-2 | CARBURETOR HEAT CONTROL | |
| | Description/Operation | 1 |
| | General | 1 |
| | Troubleshooting | 101 |
| | Maintenance Practices | 201 |
| | Removal/Installation | 201 |
| | Adjustment/Operational Test | 201 |
| 30-1-3 | CARBURETOR HEAT SHUTOFF VALVE | |
| | Description/Operation | 1 |
| | General | 1 |
| 30-3-1 | PITOT HEATER | |
| | Description/Operation | 1 |
| | General | 1 |
| | Troubleshooting | 101 |
| | Maintenance Practices | 201 |
| | Removal/Installation of Pitot Heater | 201 |
| | Removal/Installation of Pitot Heater Switch | 201 |
| | Operational Test of Pitot Heater | 201 |

AA-5 SERIES
MAINTENANCE MANUAL

| <u>NUMBER</u> | | <u>PAGE</u> |
|---------------|-----------------------------|-------------|
| 30-4-1 | WINDSHIELD DEFROSTER SYSTEM | |
| | Description/Operation | 1 |
| | General | 1 |

**AA-5 SERIES
MAINTENANCE MANUAL**

ICE AND RAIN PROTECTION - DESCRIPTION/OPERATION

1. General

This Chapter includes those units and components which are installed on the AA-5, AA-5A and AA-5B aircraft, as a means of preventing and disposing of ice formation in the carburetor and pitot system, and the elimination of frost and fog on the windows and windshield.

This Chapter contains the following systems and their related components.

Carburetor Heat System

Pitot Heat System

Windshield Defrosting and Window Defogging System

CARBURETOR HEAT SYSTEM — DESCRIPTION/OPERATION

1. General

The aircraft engine is equipped with a carburetor heat system which is used when carburetor icing conditions exist. The system provides a source of heated air to the carburetor from an alternate hot air source of the induction system. The system is controlled from the instrument panel by the carburetor heat control which is connected to a shutoff valve on the carburetor air box by a wire linkage. When the carburetor heat control is in the OFF (pushed in) position, filtered air is drawn through ducting into the carburetor. On the AA-5, AA-5A and AA-5B aircraft when the carburetor heat control is in the ON (pulled out) position, the shutoff valve shuts off the filtered air source and warm, unfiltered air from a shroud around the exhaust system is directed to the carburetor.

NOTE: On AA-5, AA-5A, and AA-5B aircraft, limited operation of the carburetor heat system is recommended since no filter is incorporated in the hot air source.

2. Major Components and Their Location

A. Carburetor Heat System

| <u>Unit</u> | <u>No. Per Aircraft</u> | <u>Location</u> |
|--------------------------------------|-------------------------|--|
| Carburetor Heat Control | 1 | On lower instrument panel to left of throttle. |
| Carburetor Heat Shutoff Valve | 1 | On carburetor air box housing. |
| Carburetor Heat Control Cable (Wire) | 1 | Runs from control handle on instrument panel to shutoff valve on carburetor air box. |

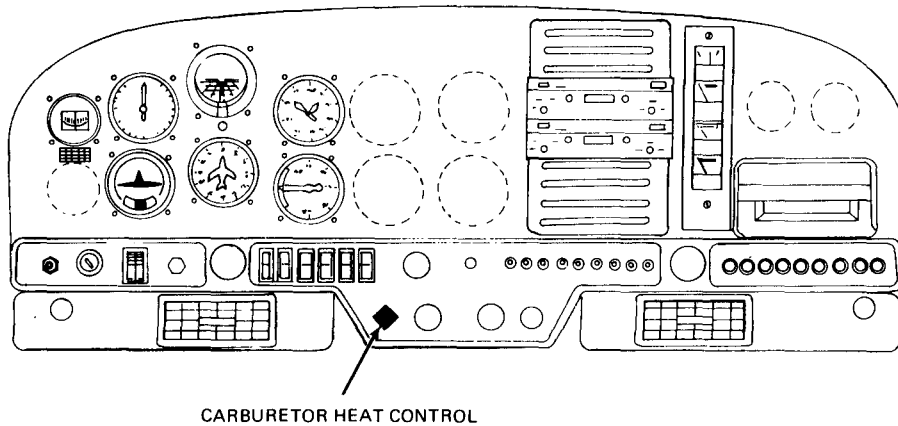

**Carburetor Heat Control (AA-5, AA-5A, and AA-5B)
Figure 1**

AA-5 SERIES
MAINTENANCE MANUAL

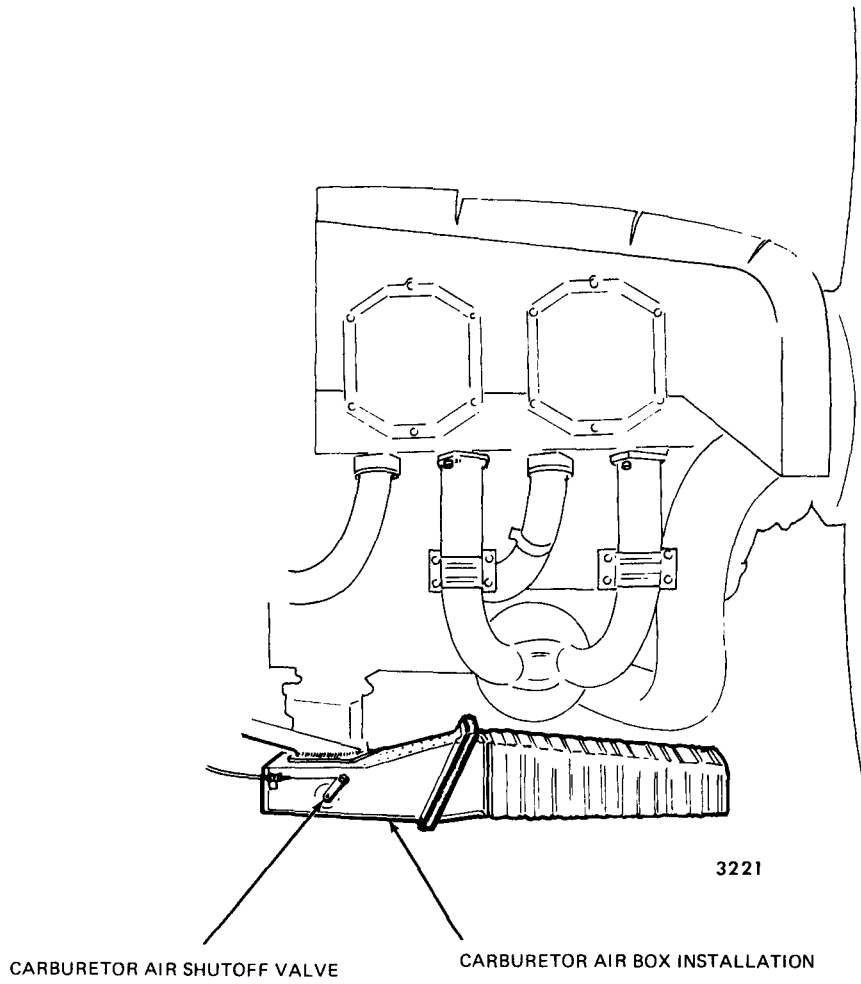

Carburetor Air Box Installation - AA-5 Serial No. 0001 thru 0640
Figure 2

AA-5 SERIES
MAINTENANCE MANUAL

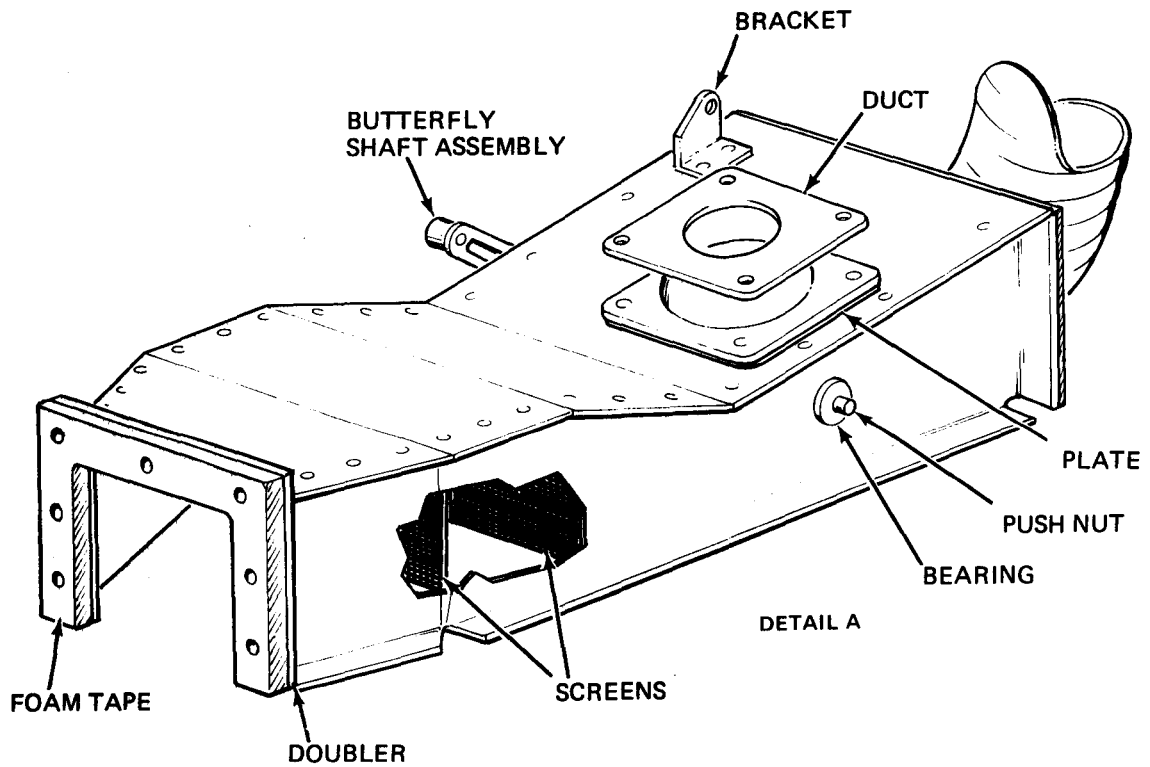
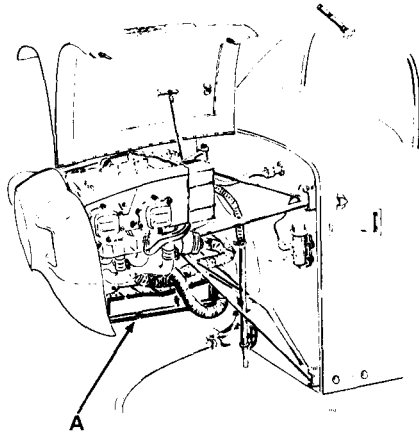

Carburetor Air Box Installation — AA5-0641 and Sub. and AA5A-0001 and Sub.
Figure 3

AA-5 SERIES
MAINTENANCE MANUAL

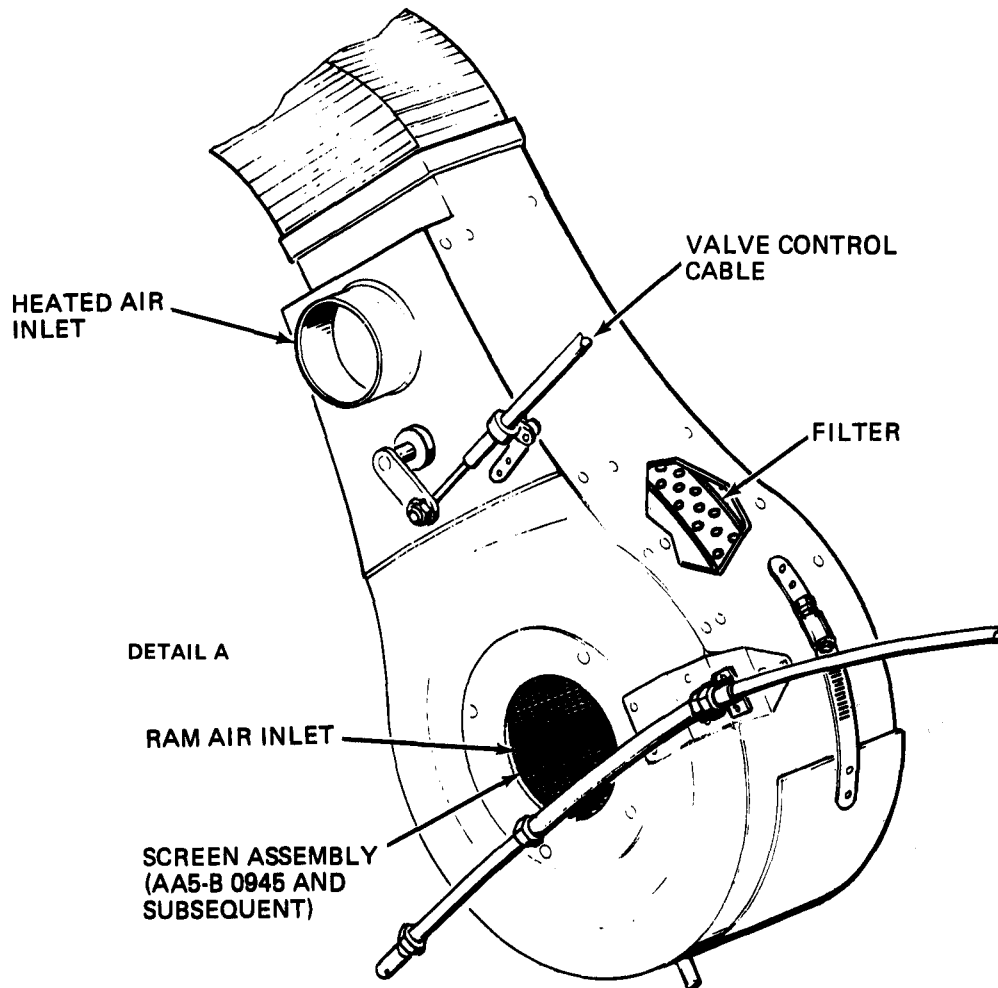
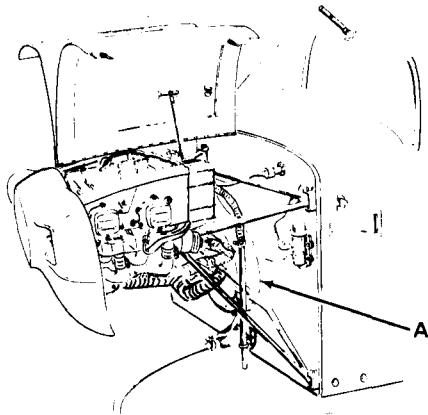

3486

Carburetor Air Box Installation — AA-5B
Figure 4

CARBURETOR HEAT SYSTEM — MAINTENANCE PRACTICES

1. Carburetor Heat System — Operational Test

- A. Disconnect the hot air duct at the air box assembly.
- B. Pull the carburetor heat control knob out (ON position) and make sure the shutoff valve on carburetor air box is in the fully open position. Push heat control knob to CLOSED position, and visually check that shutoff valve is fully closed. Ensure no binding exists throughout travel of heat control.

NOTE: It is necessary to operate the aircraft engine to operationally test the carburetor heat system.

WARNING: ENSURE THAT PROPELLER AREA IS CLEAR PRIOR TO STARTING ENGINE.

- C. Start and run engine: Refer to Pilot's Operating Handbook.

- (1) Run engine at 1800 rpm.
- (2) Pull carburetor heat control out (ON position) and check for rpm drop which indicates heat to carburetor.
- (3) Push carburetor heat control in (OFF position) and note increase in rpm.

NOTE: Limited operation of the carburetor heat system is recommended since no filter is incorporated in the hot air source.

- D. Shut down engine: Refer to Pilot's Operating Handbook.

AA-5 SERIES
MAINTENANCE MANUAL

CARBURETOR HEAT CONTROL - DESCRIPTION/OPERATION

1. General

The carburetor heat control is used to control the flow of heated air to the carburetor during icing conditions. It consists of a control knob mounted on the lower instrument panel to the left of the throttle. The heat control is connected to a shutoff valve mounted on the carburetor air box by a wire linkage and is a push/pull type control. When it is pulled out the carburetor heat system is ON; pushing it in turns the system to OFF.

**AA-5 SERIES
MAINTENANCE MANUAL**

CARBURETOR HEAT CONTROL - TROUBLE SHOOTING

| TROUBLE | PROBABLE CAUSE | REMEDY |
|--|--|--|
| Control will not operate through full travel range. | Linkage binding, broken or crimped | Adjust linkage or replace as required. |
| | Control binding in instrument panel | Clean, adjust, and lubricate as required. |
| | Air shutoff valve binding or stuck on carburetor air box | Clean, adjust, lubricate or replace valve as required. |
| Control moves through full range of travel but does not fully shut off, or restricts flow of heated air to carburetor. | Control and linkage improperly adjusted | Adjust control and linkage. See Section 30-1-1, page 201 of this manual. |

CARBURETOR HEAT CONTROL — MAINTENANCE PRACTICES

1. Carburetor Heat Control Removal/Installation

A. Removal

- (1) Disconnect the carburetor heat cable from the shutoff valve on carburetor air box by loosening the clamp bolt assembly.
- (2) Loosen the clamp on the air box assembly and slide the cable from the clamp.
- (3) On AA-5 and AA-5A aircraft, remove the clamp securing the carburetor heat control cable and the throttle cable to the instrument panel support. On AA-5B aircraft, remove plastic clamps that secure cable to wiring bundle.
- (4) Remove the locknut behind the instrument panel that secures the carburetor heat control.
- (5) Remove the control assembly by pulling it through the firewall and instrument panel.

B. Installation

- (1) Pass the end of the cable through the instrument panel and install the nut securing cable clamp to the instrument panel.
- (2) Slide the cable end through the firewall and the clamp on the side of the air box assembly and connect cable loosely to the air box control arm.
- (3) On AA-5 and AA-5A aircraft, install the clamps that secure the carburetor heat control cable and throttle cable to the instrument panel support. On AA-5B aircraft install the plastic clamps that secure cable to wiring bundle.
- (4) On AA-5 and AA-5A aircraft, adjust the cable to provide a minimum 4-1/2 inch bend radius and tighten the clamps on the instrument panel brace and the air box.

NOTE: On the Model AA-5 aircraft, the two clamps on the instrument panel brace also secure the throttle cable. Ensure that throttle cable maintains a minimum bend of 4-1/2 inches.

- (5) Seal opening in firewall around carburetor heat control cable with Coast Pro-Seal 700 Firewall Sealant (MIL-S-38249, Type 1) manufactured by Essex Chemical Corp., 19451 Susana Rd., Compton, California 90221.

2. Carburetor Heat Control Adjustment/Operational Test

A. Adjustment

- (1) Position the carburetor heat control arm in the completely closed position. Place a 1/8 inch spacer between the control knob and control cable housing. Refer to Figure 201.

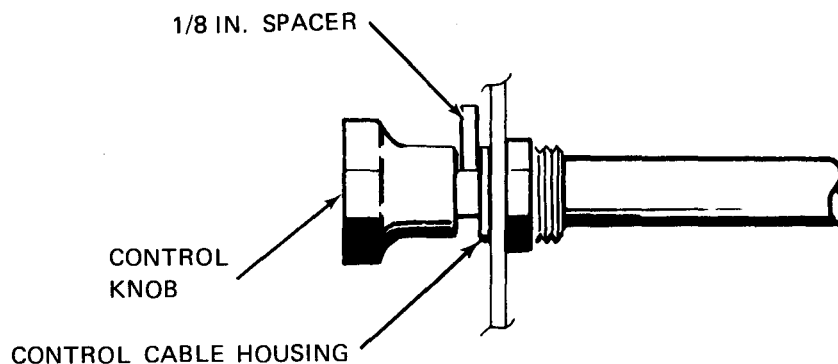

Typical Control Knob Rigging
Figure 201

AA-5 SERIES
MAINTENANCE MANUAL

- (2) With the carburetor heat control in the fully closed position and the control knob against the spacer, tighten the cable clamp on the side of the carburetor air box and the control arm attaching bolt. Remove the spacer from the control knob and check carburetor heat control operation.
- (3) Attach and bend the carburetor heat control cable wire (Figure 202). Tighten clamp and install the cotter pin.

B. Operational Test

Check operation of the carburetor heat control. Control should have 1/8 inch travel remaining with the control arm in fully closed position. Control cable should have 4-1/2 inches minimum bend radius.

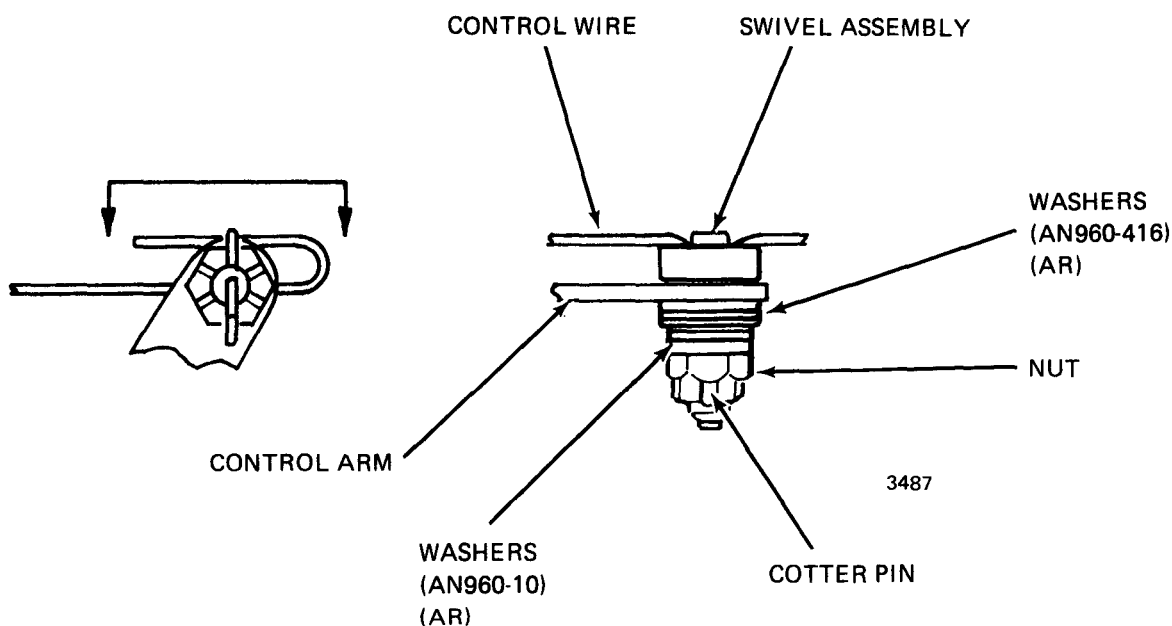

Carburetor Heat Control Wire Installation
Figure 202

AA-5 SERIES
MAINTENANCE MANUAL

CARBURETOR HEAT SHUTOFF VALVE - DESCRIPTION/OPERATION

1. General (See Figures 2, 3 and 4 of this chapter.)

The carburetor heat shutoff valve is an integral part of the carburetor air box. The valve control arm is located on the exterior section of the carburetor air box and is connected to the carburetor heat control lever by a control wire assembly. When the shutoff valve is open, heated air is diverted to the carburetor air intake. Carburetor heat is shut off when the valve is closed.

Since the carburetor heat shutoff valve is an integral part of the carburetor air box, removal or replacement of the valve requires removal of carburetor air box. (Refer to Chapter 73 of this manual).

To perform an operational test on the carburetor heat shutoff valve refer to 30-1-0, this chapter.

PITOT HEATER - DESCRIPTION/OPERATION

1. General

The pitot heating system (Figure 1) consists of an electric heating element which is an integral part of the pitot tube, a receptacle for connection to the element, a fuse and fuse holder, an OFF-ON switch, and associated wiring. The switch and fuse holder are of plastic construction and are mounted on the lower part of the instrument panel. The heater uses a 15-amp fuse (see Figure 2). The purpose of the pitot heater is to prevent or eliminate the formation of ice inside the pitot tube during aircraft flight. The heated pitot tube is an optional item.

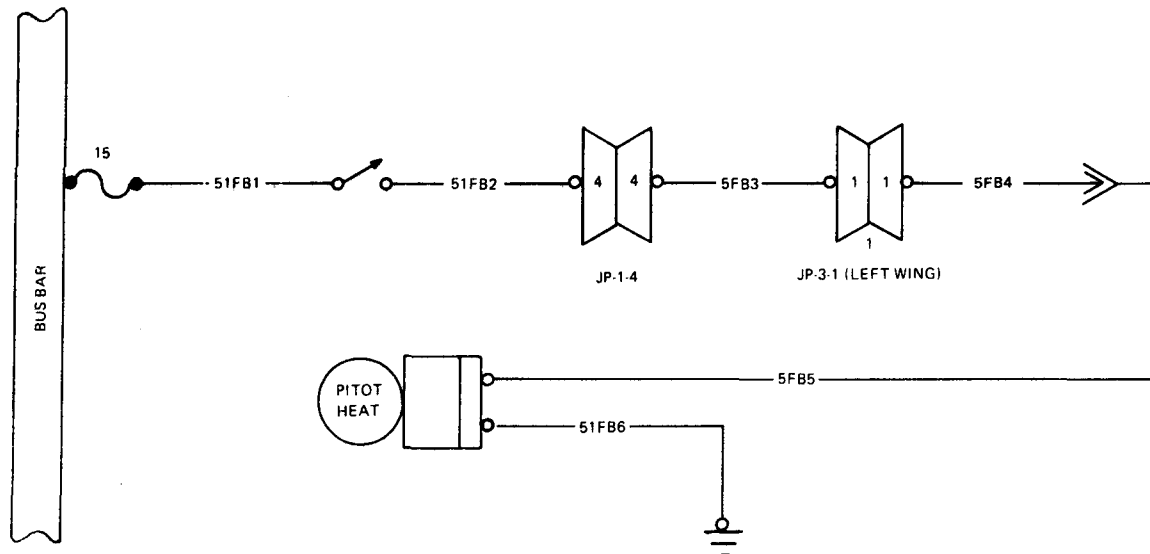

3488

Pitot Heater Circuit
Figure 1

AA-5 SERIES
MAINTENANCE MANUAL

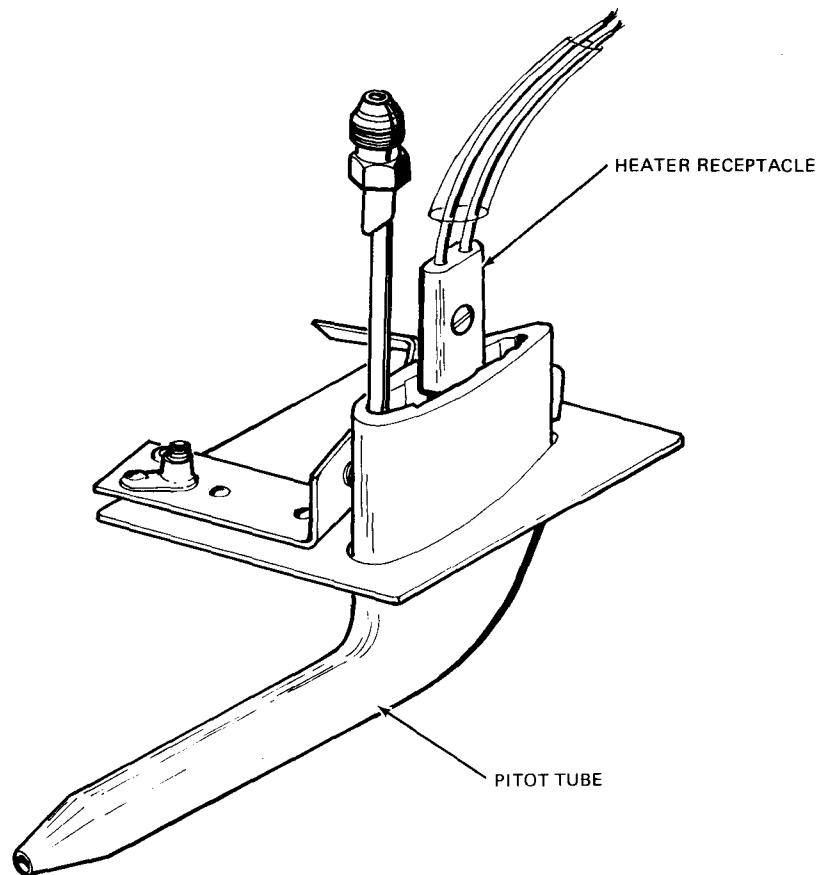
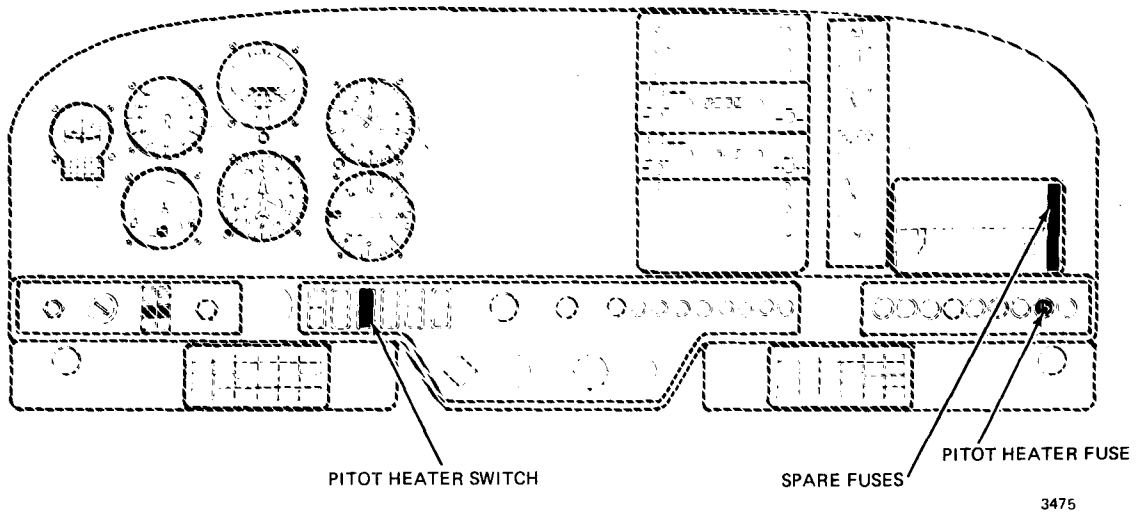

Pitot Heater System
Figure 2

PITOT HEATER — TROUBLESHOOTING

1. Troubleshooting Pitot Heater System

| TROUBLE | PROBABLE CAUSE | REMEDY |
|---------------------------|---------------------------|--|
| Pitot tube fails to heat. | Blown fuse | Replace with properly rated fuse. |
| | Defective wiring | Check with ohmmeter and repair as necessary. |
| | Heater element burned out | Replace pitot tube. |

PITOT HEATER - MAINTENANCE PRACTICES

1. Removal/Installation of Pitot Heater

When the pitot heater becomes inoperative, the pitot tube assembly must be replaced. For removal/installation procedures refer to Chapter 34.

2. Removal/Installation of Pitot Heater Switch

A. Remove Pitot Heater Switch

- (1) Ensure that master switch is in OFF position.
- (2) Reach behind instrument panel and push switch unit out through the face of the panel.
- (3) Disconnect wiring from switch terminals.

B. Install Pitot Heater Switch

- (1) Ensure that master switch is in OFF position.
- (2) Connect wiring to switch terminals.
- (3) Position switch in place on instrument panel and push switch into mounting hole until switch snaps into panel.

3. Operational Test of Pitot Heater

A. Test Pitot Heater

WARNING: WHEN THE PITOT HEATER IS OPERATING THE PITOT TUBE BECOMES EXTREMELY HOT. PHYSICAL CONTACT COULD RESULT IN A SEVERE BURN.

- (1) Place master switch to ON position.
- (2) Place pitot heater switch to ON position. Within 2 or 3 seconds pitot tube will begin to get warm.
- (3) Lightly feel the pitot tube immediately after the pitot heater switch has been placed in ON position.

NOTE: Ground operation of the pitot heater should be held to a minimum during operational checks.

- (4) Place pitot heater switch and master switch to OFF position.

**AA-5 SERIES
MAINTENANCE MANUAL**

WINDSHIELD DEFROSTER - DESCRIPTION/OPERATION

1. General

To provide for windshield defrosting, flexible ducts are connected to the plenum assembly of the heating system and terminated just below the sliding doors located on the forward panel deck. Operation of the defroster is accomplished by pulling the push-pull cabin heat control out and opening the sliding doors on the defroster outlets (see Figure 1).

AA-5 SERIES
MAINTENANCE MANUAL

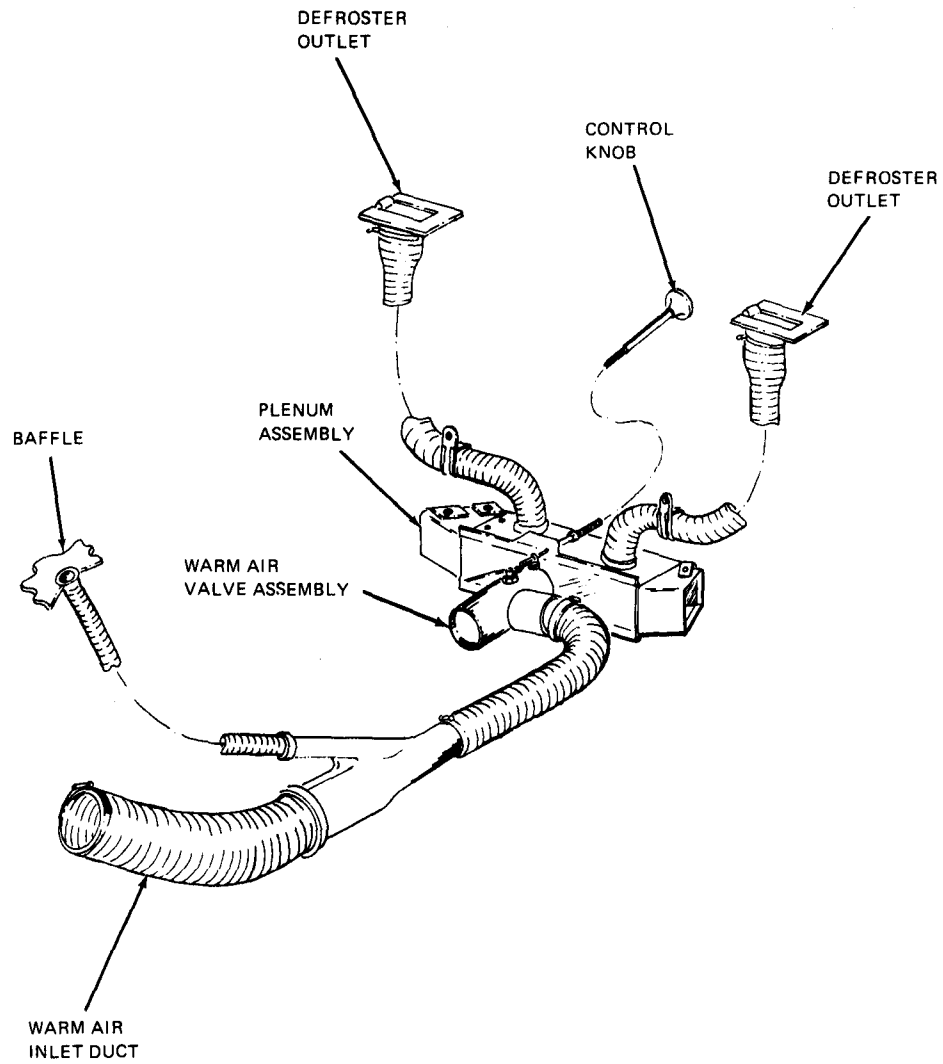

Defrosting System AA5-0001 through 0834 and AA5B-0001 through 0522 (Sheet 1 of 4)
Figure 1

AA-5 SERIES
MAINTENANCE MANUAL

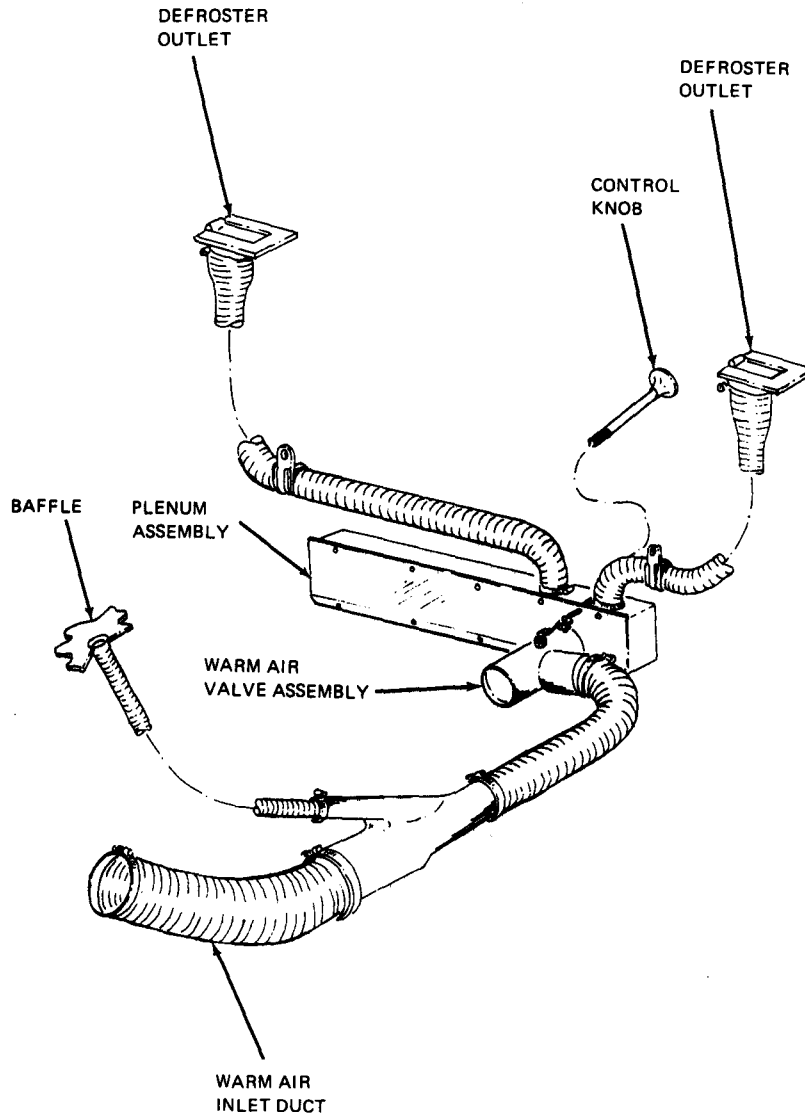

Defrosting System AA5B-0001 through 0280, 0283, and 0284 (Sheet 2 of 4)
Figure 1

AA-5 SERIES
MAINTENANCE MANUAL

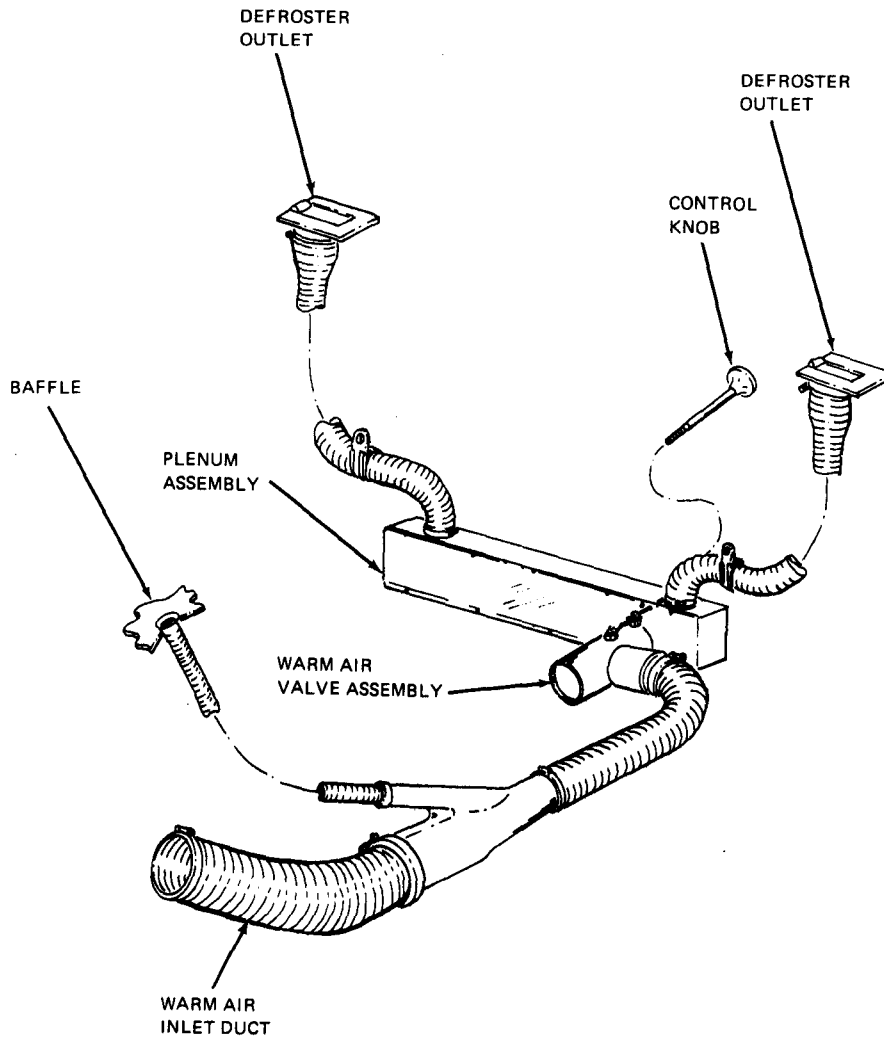

Defrosting System AA5B-0281, 0282, and 0285 through 0399 (Sheet 3 of 4)
Figure 1

AA-5 SERIES
MAINTENANCE MANUAL

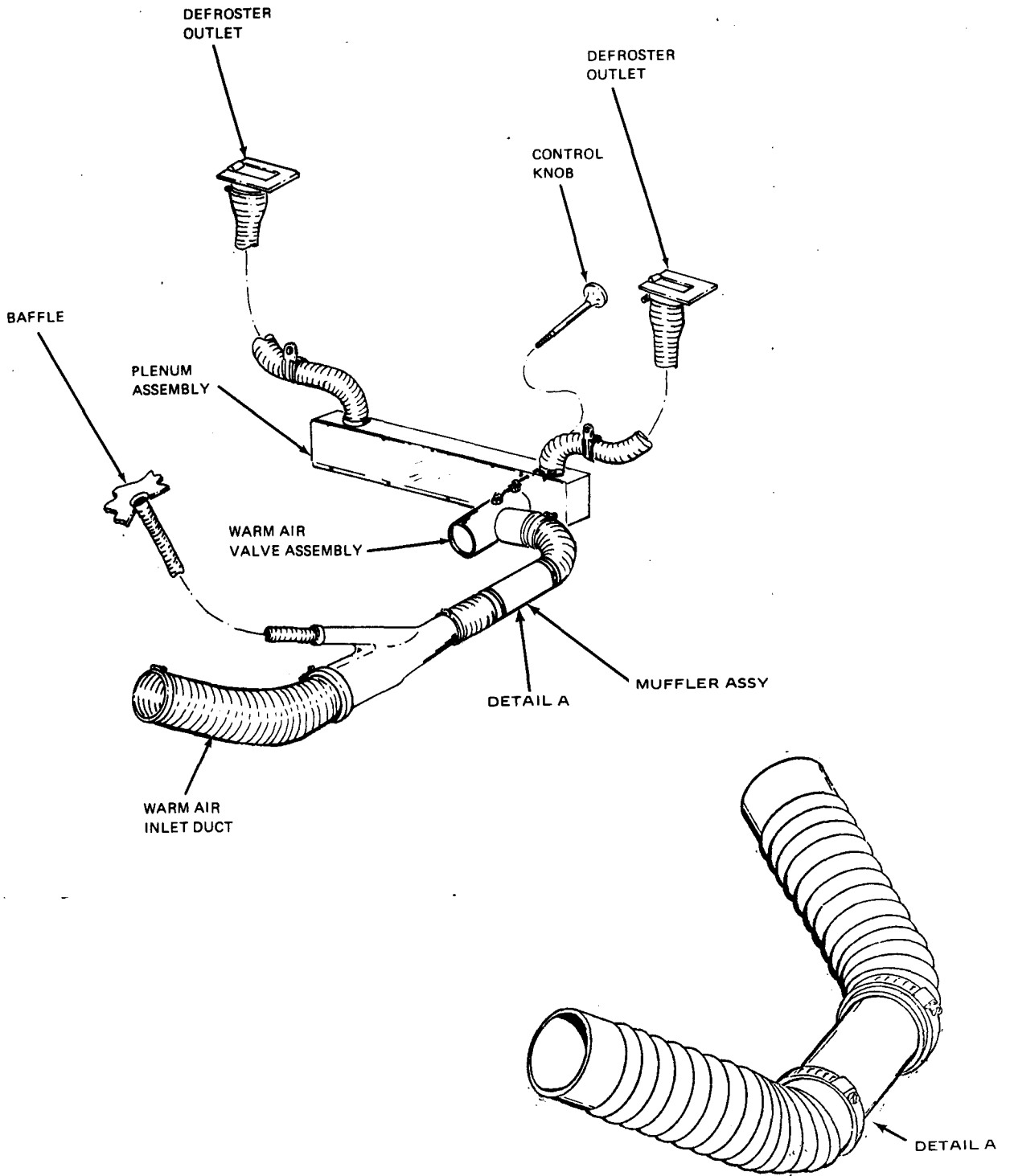

Heating System AA5A-0523 and Subsequent AA5B-0400 and Subsequent (Sheet 4 of 4)
Figure 1

AA-5 SERIES
MAINTENANCE MANUAL

CHAPTER 32

LANDING GEAR

TABLE OF CONTENTS

| <u>NUMBER</u> | | <u>PAGE</u> |
|---------------|--|-------------|
| 32-0 | LANDING GEAR | |
| | Description/Operation | 1 |
| | General | 1 |
| 32-1-1 | MAIN LANDING GEAR | |
| | Description/Operation | 1 |
| | General | 1 |
| | Maintenance Practices | 201 |
| | Removal/Installation of Main Landing Gear | 201 |
| | Visual Inspection of Main Landing Gear | 204 |
| | Repair of Main Landing Gear Strut | 204 |
| 32-2-1 | NOSE LANDING GEAR | |
| | Description/Operation | 1 |
| | General | 1 |
| | Maintenance Practices | 201 |
| | Removal/Installation of Nose Landing Gear | 201 |
| | Inspection and Minor Repair of Nose Landing Gear | 206 |
| | Removal/Installation of Shock Absorbers | 206 |
| 32-4-1 | WHEELS AND TIRES | |
| | Description/Operation | 1 |
| | General | 1 |
| | Maintenance Practices | 201 |
| | Removal/Installation of Main Gear Wheel Assemblies | 201 |
| | Disassembly/Reassembly of Main Gear Wheel Assemblies | 201 |
| | Removal/Installation of Nose Wheel Assembly | 203 |
| | Disassembly/Reassembly of Nose Wheel Assembly | 204 |
| | Removal/Installation of Main Wheel Fairing | 206 |

**AA-5 SERIES
MAINTENANCE MANUAL**

| <u>NUMBER</u> | <u>PAGE</u> |
|--|-------------|
| Removal/Installation of Nose Wheel Fairing | 207 |
| Main Landing Gear Wheel Alignment | 207 |
| 32-4-2 BRAKES | |
| Description/Operation | 1 |
| General | 1 |
| Special Tools | 1 |
| Maintenance Practices | 201 |
| Removal/Installation of Master Cylinder | 201 |
| Disassembly/Reassembly of Master Cylinder- Non-Reservoir Type | 201 |
| Disassembly/Reassembly of Master Cylinder- Reservoir Type | 203 |
| Removal/Installation of Wheel Brake Assemblies | 205 |
| Bleeding Hydraulic Brake System | 205 |
| Cleaning Brake System Parts | 206 |
| Inspection of Brake System Parts | 206 |
| Testing Brake Master Cylinders | 207 |
| Rigging the Parking Brake | 208 |
| Relining Brakes | 210 |

**AA-5 SERIES
MAINTENANCE MANUAL**

LANDING GEAR - DESCRIPTION/OPERATION

1. General

All models of the AA-5 aircraft utilize a non-retractable, tricycle type landing gear. The main gear consists of fiberglass struts attached to forged brackets which mount to the carry through spar. On Aircraft AA-5, Serial No. 0641 and subsequent, AA-5A and AA-5B the main gear struts are enclosed in a streamlining fairing. Forgings attached to the lower end of each main landing gear strut serve as the wheel axles and as an attaching base for the brake torque plate assembly. The nose gear is the castering type and consists of a tubular strut attached to the torque tube and yoke assembly mounted in the fuselage. On Aircraft AA-5, Serial No. 0641 and subsequent, AA-5A and AA-5B the nose gear strut has a streamlining fairing attached to the aft side.

The aircraft is furnished, at the customer's option, with wheel fairings for all three wheels. The fairings are equipped with an adjustable scraper which prevents mud and slush from entering the fairing cavity. Aircraft operation on rough field conditions, with tires out of balance, or in snow, ice, or mud can be detrimental to the life of the wheel fairings and should be avoided, if possible.

AA-5 SERIES
MAINTENANCE MANUAL

MAIN LANDING GEAR - DESCRIPTION/OPERATION

1. General

The main landing gear consists of the right and left hand gear assemblies. Each assembly consists of a laminated fiberglass strut, forged wheel axle, attaching brackets, strut fairings, and attaching hardware. Wheel fairings are a customer option. When wheel fairings are installed on the landing gear, the strut fairing caps cannot be used.

MAIN LANDING GEAR - MAINTENANCE PRACTICES

1. Removal/Installation of Main Landing Gear

A. Remove Main Landing Gear (See Figure 201)

- (1) Support the aircraft on jacks (refer to Chapter 7).
- (2) Remove the wing and wing root (refer to Chapter 57).
- (3) Bleed the fluid from the brake system and disconnect the brake line at the fuselage.
- (4) Remove the fuel tank sump (refer to Chapter 28).
- (5) Remove main landing gear wheel (refer to 32-4-1).
- (6) Support the main gear strut assembly and remove nuts (3), bolts (4), and washers (5) that secure the strut brackets to the spar mounting bracket (9) and remove the landing gear assembly and shims (6).
- (7) Remove bolts (7), washers (8), and remove spar mounting bracket (9).
- (8) Disassemble the landing gear strut assembly as follows:
 - (a) Remove nuts (10), bolts (11), washers (12), and separate brackets (13, 14, and 15), shims (16, 17, and 18), spacer (19), and spring plate (20) from strut (21).
 - (b) Remove nuts (22), bolts (23), washers (24), and separate axle (25), bracket (26), reinforcement plate (27), and shims (28) from strut (21).
 - (c) Remove nuts (29), bolts (30), and washers (31) to remove torque plate assembly (7, Figure 201, 32-4-1).

B. Install Main Landing Gear

- (1) When installing the main landing gear observe the following torque values:

| <u>BOLT DIA. (in.)</u> | <u>TORQUE (in. lb)</u> |
|------------------------|------------------------|
| 1/2 | 650-750 |
| 3/8 | 250-300 |
| 5/16 | 200-225 |

- (2) Check shims for excessive wear or hole elongation and replace if necessary. Shims must assure a tight fit.

NOTE: Install shims in same order and position as prior to disassembly.

- (3) Assemble the landing gear strut assembly as follows:
 - (a) Position torque plate assembly (7, Figure 201, 32-4-1) in place on axle (25, Figure 201) and install bolts (30), washers (31), and nuts (29).
 - (b) Assemble shims (28), axle (25), reinforcement plate (27), and bracket (26) in place on strut (21) and install bolts (23), washers (24), and nuts (22).
 - (c) Assemble shims (18, 17, and 16), spring plate (20), spacer (19), bracket (15, 14, and 13) in place on spar (21) and install bolts (11), washers (12), and nuts (10).

AA-5 SERIES
MAINTENANCE MANUAL

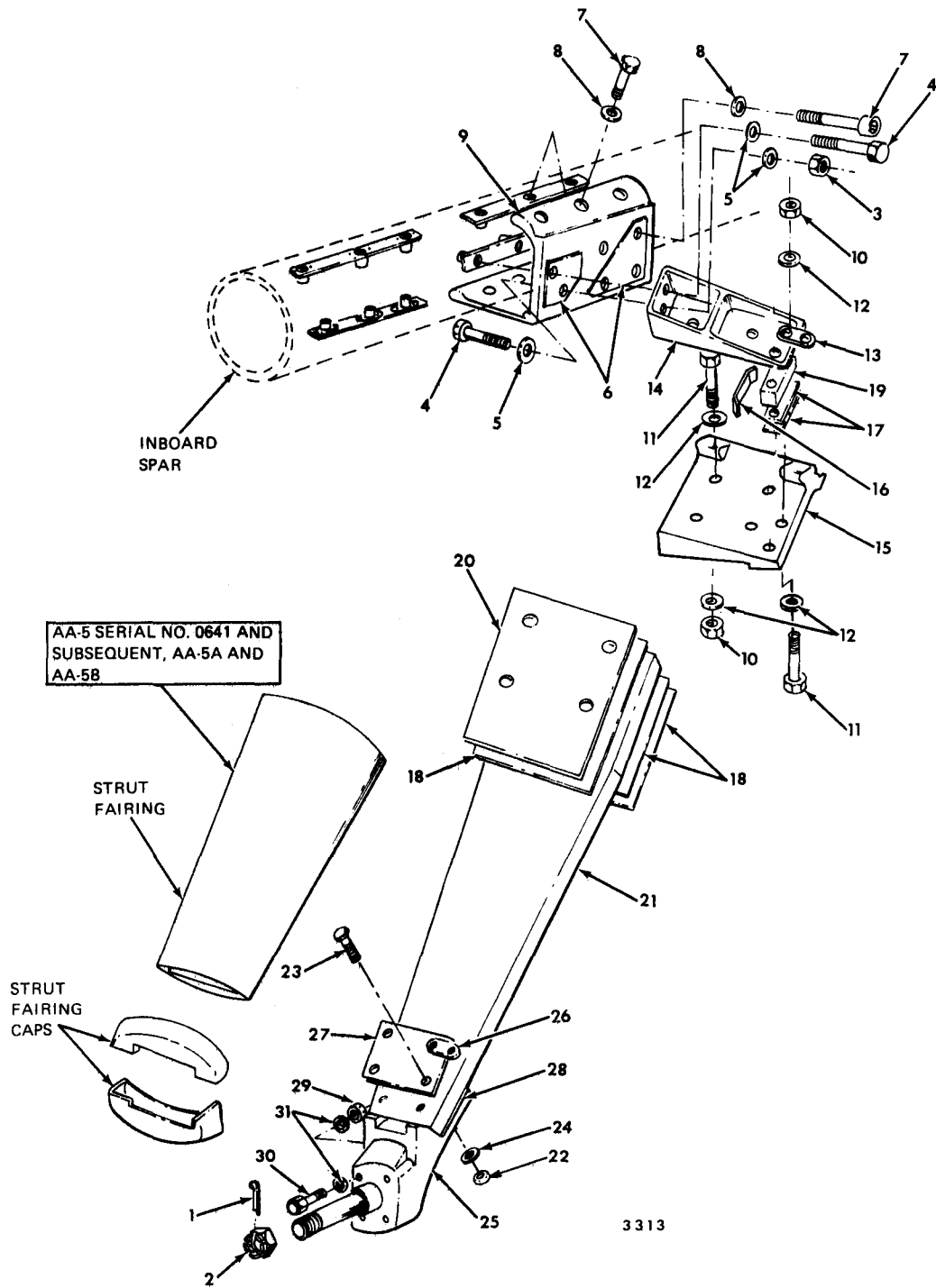

Main Landing Gear (Sheet 1 of 2)
Figure 201

**AA-5 SERIES
MAINTENANCE MANUAL**

| | |
|---------------|------------------|
| 1. Cotter Pin | 17. Shims |
| 2. Nut | 18. Shims |
| 3. Nut | 19. Spacer |
| 4. Bolt | 20. Spring Plate |
| 5. Washer | 21. Strut |
| 6. Shims | 22. Nut |
| 7. Bolt | 23. Bolt |
| 8. Washer | 24. Washer |
| 9. Bracket | 25. Axle |
| 10. Nut | 26. Bracket |
| 11. Bolt | 27. Plate |
| 12. Washer | 28. Shim |
| 13. Bracket | 29. Nut |
| 14. Bracket | 30. Bolt |
| 15. Bracket | 31. Washer |
| 16. Shim | |

**Main Landing Gear (Sheet 2 of 2)
Figure 201**

- (4) Apply an approved solid film lubricant to the mating surfaces of the inboard spar and spar mounting bracket (9). Approved solid film lubricants are:
- McLube 1708 by McGee Chemicals Co., Inc.
Lube-Lok 5396 by Allen Aircraft Products, Inc.
- (5) Position spar mounting bracket (9) in place on inboard spar and install washers (8) and bolts (7).
- (6) Position shims (6) and main gear strut assembly in place and install bolts (4), washers (5), and nuts (3) that secure strut assembly to spar mounting bracket (9) and to the inboard spar.
- (7) Install the fuel tank sump (refer to Chapter 28.)
- (8) Connect brake system fluid line at the fuselage.
- (9) Install main gear wheel on axle (25) and install nut (2) and cotter pin (1).
- (10) Service the brake system as outlined in 32-4-2, Paragraph 5.
- (11) Install wing root and wing (refer to Chapter 57).
- (12) Remove aircraft from jacks.

2. Visual Inspection of Main Landing Gear

A visual inspection of the main landing gear strut and attach brackets should be made at each 100 hour inspection and after any hard or overweight landing. Inspect the laminated fiberglass main gear struts for evidence of nicks, cracks, delamination, and deterioration of the protective paint coating. On aircraft with streamline fairing installed, inspect the struts above and below the fairing. Refer to Chapter 5 for scope of inspections and detailed procedures.

3. Repair of Main Landing Gear Strut

NOTE: (1) Minor surface delaminations are acceptable providing they do not extend more than one ply into the surface of the strut. Corner delaminations (slivers) are acceptable if they are smaller than 1/16 x 1/16 in. in size throughout their length. If airworthiness of a damaged fiberglass strut is in question, close-up photographs of the damaged area may be submitted to Grumman American Aviation Corporation for analysis and recommendations.

Corrective Action - Remove delaminated material. Smooth out minor paint chips or stone bruises with No. 150 Tri-Mite. Clean unpainted areas thoroughly with Methyl Ethyl Ketone. Seal minor surface or corner delaminations with a two-part epoxy adhesive to seal out moisture from the damaged area. Clean strut with wax and grease remover and prime with two light coats of Zinc Chromate Primer per MIL-P-8585 (see Chapter 12) and paint to match aircraft color.

NOTE: (2) Epoxy adhesive is available from the Grumman American Supply Operations or may be purchased locally.

**AA-5 SERIES
MAINTENANCE MANUAL**

NOSE LANDING GEAR — DESCRIPTION/OPERATION

1. **General**

The nose landing gear consists of a fuselage mounted torque tube and yoke assembly connected to a non-steerable strut with a castoring nose wheel mounted on the forward end. Normal servicing of the nose wheel strut includes the application of grease to the nose fork swivel and adjustment of the Belleville washers. Aircraft AA5A-0283 and subsequent and AA5B-0400 and subsequent are equipped with a pair of shock absorbers connected to the nose landing gear strut. The shock absorbers eliminate porpoising when the aircraft is rolling over rough terrain.

Shock absorber installations can be made on any AA-5, AA-5A, or AA-5B aircraft. Accessory kit AK-129 and installation services are available through Grumman American Dealers.

NOSE LANDING GEAR – MAINTENANCE PRACTICES

1. Removal/Installation of Nose Landing Gear Assembly

A. Remove Nose Landing Gear Assembly

NOTE: If the aircraft is equipped with shock absorbers, refer to Paragraph 3 for removal.

- (1) Remove the weight from the nose gear by either tying down the tail or placing a suitable support under the front of the fuselage.
- (2) Remove bolt (1, Figure 201) and spacer (2).
- (3) Remove cotter pin (3), nuts (4), washers (5), and withdraw axle rod (6) from nose wheel.
- (4) Remove plugs (7), spacers (8), and axle (9).

NOTE: Some aircraft have nose wheel fairing installed as an optional item.

- (5) Remove cotter pin (10), nut (11), washers (12, 13, and 14), fork assembly (15) with fairing assembly attached, thrust bearing (16), and O-ring (17).
- (6) Remove two attaching bolts and remove nose wheel fairing from fork assembly (15).
- (7) On aircraft AA5-0641 and subsequent, and AA-5A, and AA-5B, remove screws (18), retainer (19), and slide fairing boot (20) down the strut.
- (8) Remove nose gear boot clamp (21), screws (22), nose gear boot plate (23), and slide boot (24) down the strut.
- (9) Remove nuts (25), washers (26), bolts (27), and slide the strut (28) from the torque tube and yoke assembly. Slide boots (20) and (24) off strut (28).

NOTE: The torque tube and yoke assembly is located in the front end of the fuselage. To gain access to the torque tube and yoke assembly, some items of equipment must be removed from the cockpit area.

- (10) Remove the front seats (refer to Chapter 25).
- (11) Remove the left-hand and right-hand forward console panels. The panels may be easily removed by grasping the forward edge at the firewall and bending the panels out 90 degrees and parallel with the firewall. Then slide the panels forward far enough so that they slip out from behind the aft portion of the console.
- (12) Remove the left side fresh air box assembly.
- (13) Remove the upholstery side panels and fiberglass insulating material from the left and right-hand forward inside panels.
- (14) Remove the lower cowling (refer to Chapter 71).
- (15) Disconnect the rudder return springs by unbolting the eye bolts from the forward face of the firewall. Note that additional washers are used under the left-hand eye bolt for proper rudder pedal centering and rudder trim.
- (16) Remove the nuts that secure the right forward rudder bar attach bracket to the floor. Lift the rudder bar up and aft to provide clearance for removing left brake cylinder attach brackets on co-pilot's side.
- (17) Remove the nuts that attach the brake cylinder brackets to the floor. Lift brake cylinders free from the floor and allow pedals to rotate aft.

AA-5 SERIES
MAINTENANCE MANUAL

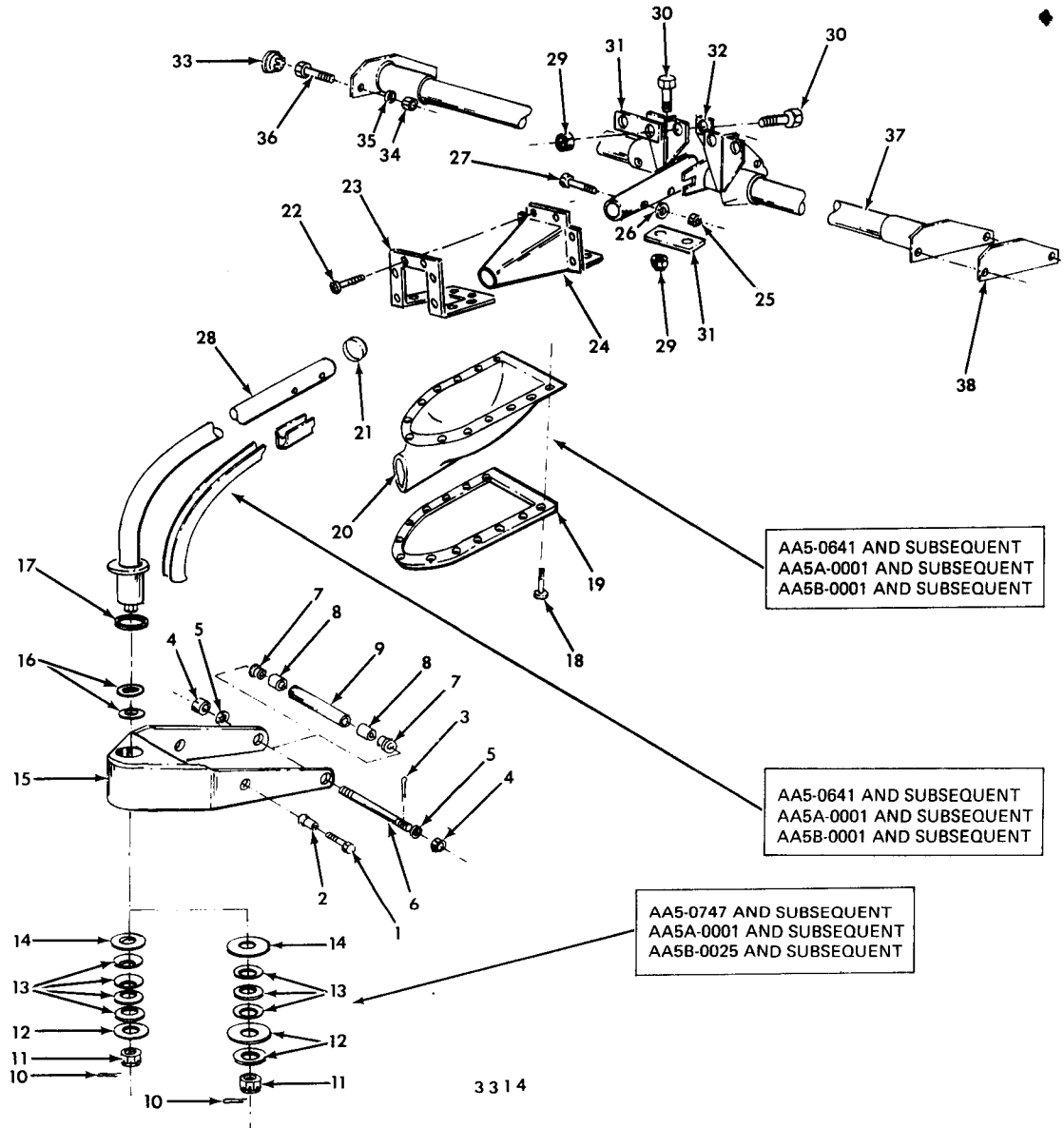

Nose Landing Gear Assembly (Sheet 1 of 2)
Figure 201

**AA-5 SERIES
MAINTENANCE MANUAL**

| | |
|------------------------|--------------------------------|
| 1. Bolt | 20. Boot |
| 2. Spacer | 21. Clamp |
| 3. Cotter Pin | 22. Screw |
| 4. Nut | 23. Plate |
| 5. Washer | 24. Boot Ass'y |
| 6. Axle Rod | 25. Nut |
| 7. Plug | 26. Washer |
| 8. Spacer | 27. Bolt |
| 9. Axle | 28. Strut Ass'y |
| 10. Cotter Pin | 29. Nut |
| 11. Nut | 30. Bolt |
| 12. Washers | 31. Doubler |
| 13. Belleville Washers | 32. Clip |
| 14. Washer | 33. Plug Button |
| 15. Fork Assembly | 34. Nut |
| 16. Thrust Bearings | 35. Washer |
| 17. O-ring | 36. Bolt |
| 18. Screw | 37. Torque Tube and Yoke Ass'y |
| 19. Retainer | 38. Shim |

**Nose Landing Gear Assembly (Sheet 2 of 2)
Figure 201**

- (18) Remove clevis pins from left and right brake cylinder attachment to rudder pedals on pilot's side.
- (19) Disconnect one end of the parking brake chain by cutting the wire which attaches it to the link on the master cylinder (pilot's side).
- (20) Move the left and right master cylinders on the pilot's side up as high as possible and against the firewall and secure them temporarily in this position.
- (21) Remove the screws and nuts which attach the throttle cable clamps to the instrument panel brace.
- (22) Remove the nuts that attach the T-column support to the floor. Lift the T-column and support assembly from the studs which protrude through the floor and allow the assembly to come as far aft as possible.
- (23) Remove nuts (29), bolts (30), doublers (31), and clips (32) that secure the center torque tube and yoke bearing supports to the floor and firewall.

AA-5 SERIES
MAINTENANCE MANUAL

- (24) Remove the four plug buttons (33) on the lower forward fuselage and the four nuts (34), washers (35), and bolts (36) which secure the ends of the torque tube and yoke assembly (37) to the fuselage side panels.

CAUTION: CARE SHOULD BE TAKEN NOT TO WEDGE THE TORQUE TUBE ASSEMBLY INTO THE FUSELAGE PANELS AS DAMAGE TO THE HONEYCOMB SKIN MAY RESULT.

- (25) Remove the torque tube and yoke assembly (37) from the fuselage by working the assembly up and aft, left end first, so that the assembly is withdrawn from under the pilot's side of the instrument panel.
- (26) Remove shims (38).

B. Install Nose Landing Gear Assembly

- (1) Carefully position the torque tube and yoke assembly (37, Figure 201) in place and install clips (32), doublers (31), bolts (30), and nuts (29) that secure the center torque tube and yoke assembly bearing supports to the firewall and the floor. Do not tighten nuts (29).
- (2) Check the clearance between the ends of the torque tube and yoke assembly (37) and the inside of the lower engine mount extrusions, and install the proper thickness shims (38) to obtain a minimum clearance between the ends of the torque tube assembly and the inside of the lower engine mount extrusions.
- (3) Install bolts (36), washers (35), and nuts (34).
- (4) Torque the center torque tube bearing support bolts (30) at the firewall and the cabin floor to 185-195 inch pounds and torque the bolts (36) that attach the ends of the torque tube assembly to the fuselage sides to 300-350 inch pounds.
- (5) Install plug buttons (33).
- (6) Position the T-column and support assembly in place and install nuts. Refer to chapter 27.
- (7) Position throttle cable in place on instrument panel brace and install cable clamps, screws, and nuts.
- (8) Position brake master cylinders on co-pilot's side in place and install washers and nuts to secure attach brackets to the floor.
- (9) Position right-hand rudder bar in place and install washer and nuts on attach brackets.
- (10) Attach the left and right brake master cylinders to the floor on the pilot's side. Attach the parking brake chain to the parking brake link on the master cylinder if equipped. Use 0.032 inch stainless steel safety wire and make a double loop through the link and through the chain. Install the two clevis pins which attach the left and right rudder pedals on the pilot's side to the master cylinders.
- (11) Install rudder return spring eye bolts in firewall using same number of washers as were removed.
- (12) Install lower cowling. Refer to Chapter 71.
- (13) Where upholstery side panels and fiberglass insulation have been removed from the forward cabin area, the fiberglass insulation may be cemented to the fuselage side skin with Uniroyal 6306 adhesive or equivalent.

**AA-5 SERIES
MAINTENANCE MANUAL**

- (14) Install right and left hand forward console panels.
 - (15) Install left side fresh air box assembly.
 - (16) Install the front seats (refer to Chapter 25).
 - (17) Slide fairing boot (20), boot plate (23), and boot assembly (24) over end of strut (28). Position strut into torque tube yoke assembly (37) and install attaching bolts (27), washers (26), and nuts (25). Torque bolts (27) to 95-110 in. lb.
 - (18) Apply sealant, RTV 102 by General Electric or RTV 732 by Dow Corning, to strut-to-torque tube connection and to bolt heads (27) and nuts (25).
 - (19) Apply sealant, Pro-Seal 700 by Coast Pro Seal or 93-004 by Dow Corning, to the mating surface of the boot assembly (24) and the firewall.
 - (20) Slide boot assembly (24) and nose gear boot plate (23) into place and secure with screws (22). Install nose gear boot clamp (21).
 - (21) On AA-5 aircraft Serial No. 0641 and subsequent, AA-5A, and AA-5B, install fairing boot (20), retainer (19), and screws (18).
 - (22) If nose wheel fairing was removed, position strut (28) through cutout in fairing.
 - (23) Assemble O-ring (17), thrust bearings (16), and fork assembly (15) in place on strut (28).
- NOTE:** Proper installation of nose gear strut and fork assembly is essential to prevent nose wheel shimmy. Refer to Figure 201 for proper installation of Belleville washers (13).
- (24) Install washers (14, 13, and 12) and nut (11).
 - (25) Install two attaching bolts that secure nose wheel fairing to fork assembly (15).
 - (26) Assemble axle (9), spacers (8), and plugs (7), in nose wheel. Position nose wheel in fork assembly (15), and insert axle rod (6) through fork and wheel and through fairing mount brackets.
 - (27) Install washers (5), nuts (4) and tighten until a very slight drag is evident when the wheel is rotated. Install cotter pin (3).
 - (28) Install spacer (2) and bolt (1).
 - (29) Proper nose fork friction is attained by adjustment of torque at nut (11). Tighten nuts (11) until a 10-22 lb drag is attained at the axle centerline when the fork is rotated. See Figure 202 for proper nose fork friction measurement. The cotter pin (10, Figure 201) must be in place for this measurement.

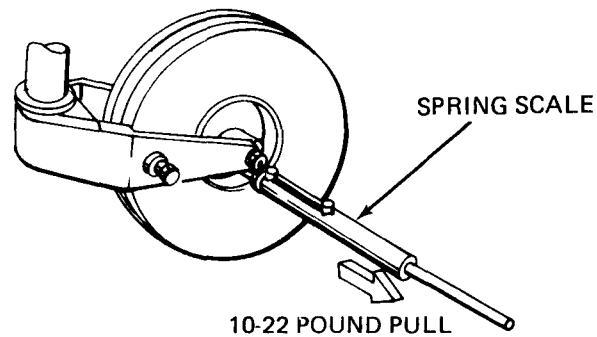

Nose Fork Friction Measurement
Figure 202

**AA-5 SERIES
MAINTENANCE MANUAL**

2. Inspection and Minor Repair of Nose Landing Gear

A. Visually Inspect Nose Landing Gear

- (1) Inspect the steel tube nose gear for nicks, rust or damage to protective paint coating.
- (2) Perform a thorough inspection of the nose landing gear at each 100-hour inspection and after any hard or overweight landing. Refer to Chapter 5 for scope of inspections and detailed procedures.

B. Repair Nose Landing Gear Minor Damage

- (1) Smooth out minor nicks with fine sandpaper.
- (2) Use 150 Trimate sandpaper to remove all rust and smooth out damaged paint.
- (3) Clean strut with wax and grease remover and prime with two light coats of zinc chromate primer per MIL-P-8585. See Chapter 12.
- (4) Apply final coat of paint to match aircraft color.
- (5) Inspect the nose fork bearing cup to strut fillet for cracks, corrosion, deterioration, and damage. See area D, Figure 203, Chapter 5. If any discrepancies are found, place a 150 foot-pound torque load on cup (suitably protecting the bearing surface), preferably around the stop plate. Any detectable rotation is reason for strut replacement. After testing, replace fillet as follows:
 - (a) Remove cup-to-strut fillet with hand abrasive. Remove rust and paint from strut, 1.5 inch minimum, upward from cup stop plate.
 - (b) Apply Loctite 290 Adhesive/Sealant (wicking). Loctite Corporation, to any cracks remaining in cup to strut bondline.
 - (c) Apply a uniform 0.12 inch radius fillet of sealant* to replace fillet removed. Also apply sealant on strut up 1.5 inch minimum from cup stop plate.
 - (d) After sealant has cured, prime area with two light coats of zinc chromate primer and paint strut to match aircraft color.

*Approved Sealants (PR-1422, Class B-1/2 is available through Gulfstream Aerospace Supply Operations:

EC-1675B, Class B-1/2, B-2 or B-4 with EC-1675A accelerator 3M Company.
890 Class B-2 or B-4 with 890 curing agent, Coast Pro-Seal Company.
PR-1422, Class B-1/2 or B-2 with accelerator, Products Research and Chemical Corporation.
PR-1436G, Class B-1/2 or B-4 with accelerator, Products Research and Chemical Corporation.

3. Removal/Installation of Shock Absorbers

A. Remove Shock Absorbers

NOTE; To remove the nose landing gear and the torque tube and yoke assembly from aircraft equipped with shock absorbers, the shock absorbers must be removed. Some steps in this paragraph will duplicate some steps in Paragraph 1. However, this procedure should be used in conjunction with the procedure outlined in Paragraph 1.

**AA-5 SERIES
MAINTENANCE MANUAL**

- (1) Remove the weight from the nose gear by applying downward pressure on the horizontal stabilizer root and placing a suitable support under the front of the fuselage.
 - (2) Remove the lower cowling (refer to Chapter 71).
 - (3) Remove nuts (1, Figure 203), washers (2), bolts (3), and remove shock absorbers (4). Remove bushings (5) from upper end of shock absorbers (4).
 - (4) Remove nuts (6), washers (7), bolts (8), and remove bracket (9). Slide strut (10) out of torque tube and yoke assembly (11).
 - (5) Remove screws (12) from firewall seal box assembly and remove box cover (13) and box (14) from torque tube and yoke assembly (11).
 - (6) Remove seals (15) from torque tube and yoke assembly (11).
 - (7) Remove nuts (16), washers (17), bolts (18), bracket (19), washers (20) and doublers (21). The two doublers (21) are used behind the bracket against the firewall instead of washers.
- B. Install Shock Absorbers (See Figure 203).**
- (1) Assemble washers (20) on bolts (18) and install bolts through firewall.
 - (2) Install doublers (21) on the four lower bolts and washers (20) on the two upper bolts.
 - (3) Slide bracket (19) onto bolts (18) and install washers (17) and nuts (16). Torque the two upper bolts to 120 ± 20 in. lb and the four lower bolts to 175 ± 15 in. lb.
- WARNING: USE CLEANING SOLVENT IN A WELL VENTILATED AREA. AVOID BREATHING FUMES. KEEP AWAY FROM FLAMES.**
- (4) Use Stoddard solvent to clean firewall area around nose gear torque tube and flanges of firewall seal box assembly.
 - (5) Install seals (15) on torque tube and yoke assembly (11) with thin edge of seal up and thin seal outboard.
 - (6) Coat aft side (firewall side) of box (14) flanges with firewall sealant, Pro-Seal 700 and position box in place against firewall, making sure seals (15) are inside the box. Secure box to firewall with screws (12).
 - (7) Be sure that seals (15) remain in place and install box cover (13). Secure cover with four screws (12).
 - (8) Use firewall sealant and seal any opening between box and box cover so that the box forms an air tight seal around the torque tube.
 - (9) Position shock absorbers (4) in place on lower bracket. Coat bolt (AN4-13) with MIL-G-7711 or equivalent grease and insert bolt (3). Install washers (2) and (2A) (AN960-416 and AN960-416L) as required to obtain a side play of 0.010 to 0.040 inch. Install nut (1) (AN310-4) until snug, then tighten to next hole. Safety with cotter pin (MS24665-132).
 - (10) Slide nose gear strut (10) into torque tube and yoke assembly (11); position bracket (9) in place on torque tube and yoke assembly (11); and install bolts (8), washers (7), and nuts (6). Torque bolts to 175 ± 15 in. lb.
 - (11) Insert bushings (5) in top mounting holes in shock absorbers (4); align holes in shock absorbers with holes in bracket (19); and install bolts (3), washers (2), and nuts (1). Torque bolts to 175 ± 15 in. lb.
 - (12) Remove support from front of fuselage.
 - (13) Install lower cowling (refer to Chapter 71).

AA-5 SERIES
MAINTENANCE MANUAL

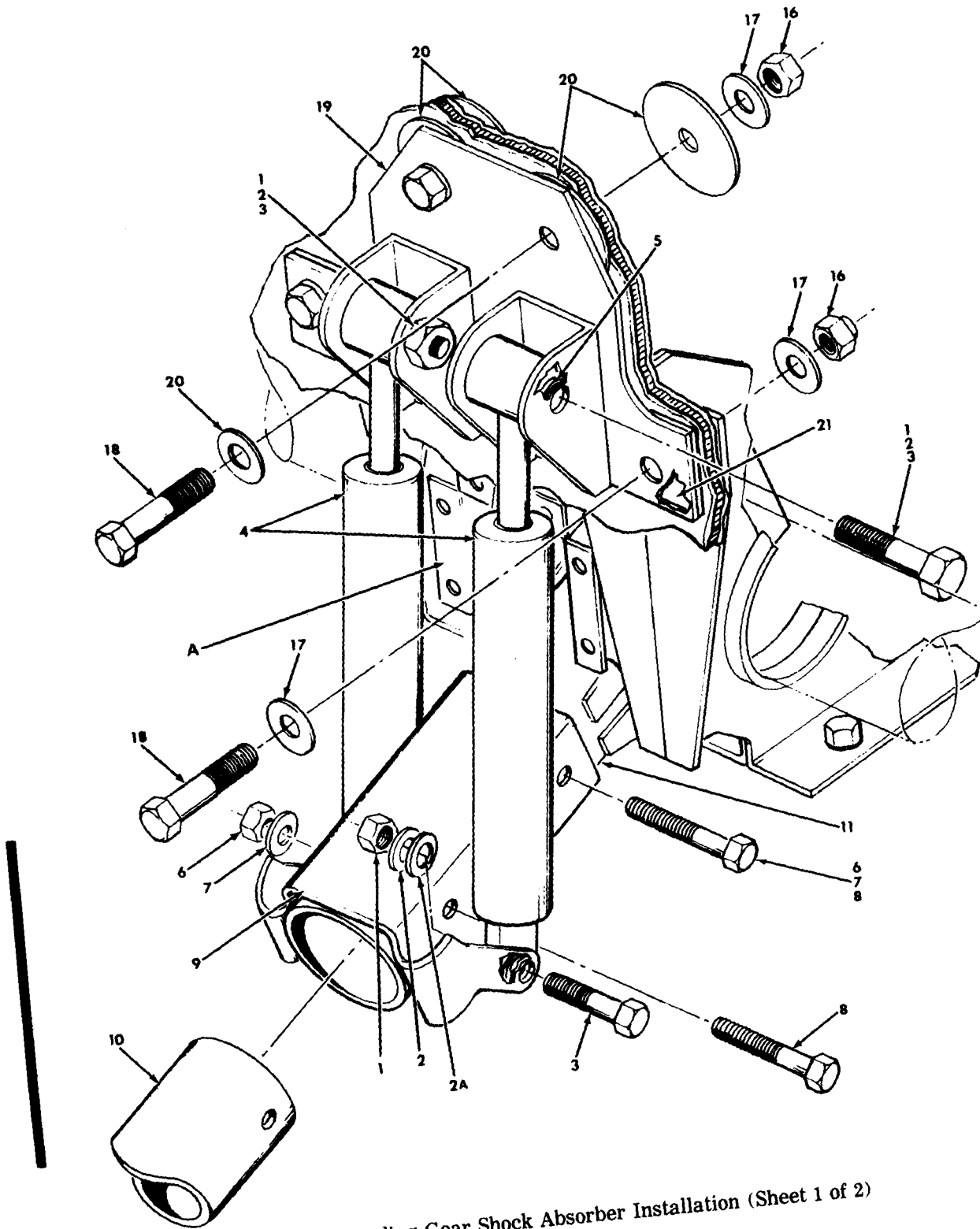

Nose Landing Gear Shock Absorber Installation (Sheet 1 of 2)
Figure 203

**AA-5 SERIES
MAINTENANCE MANUAL**

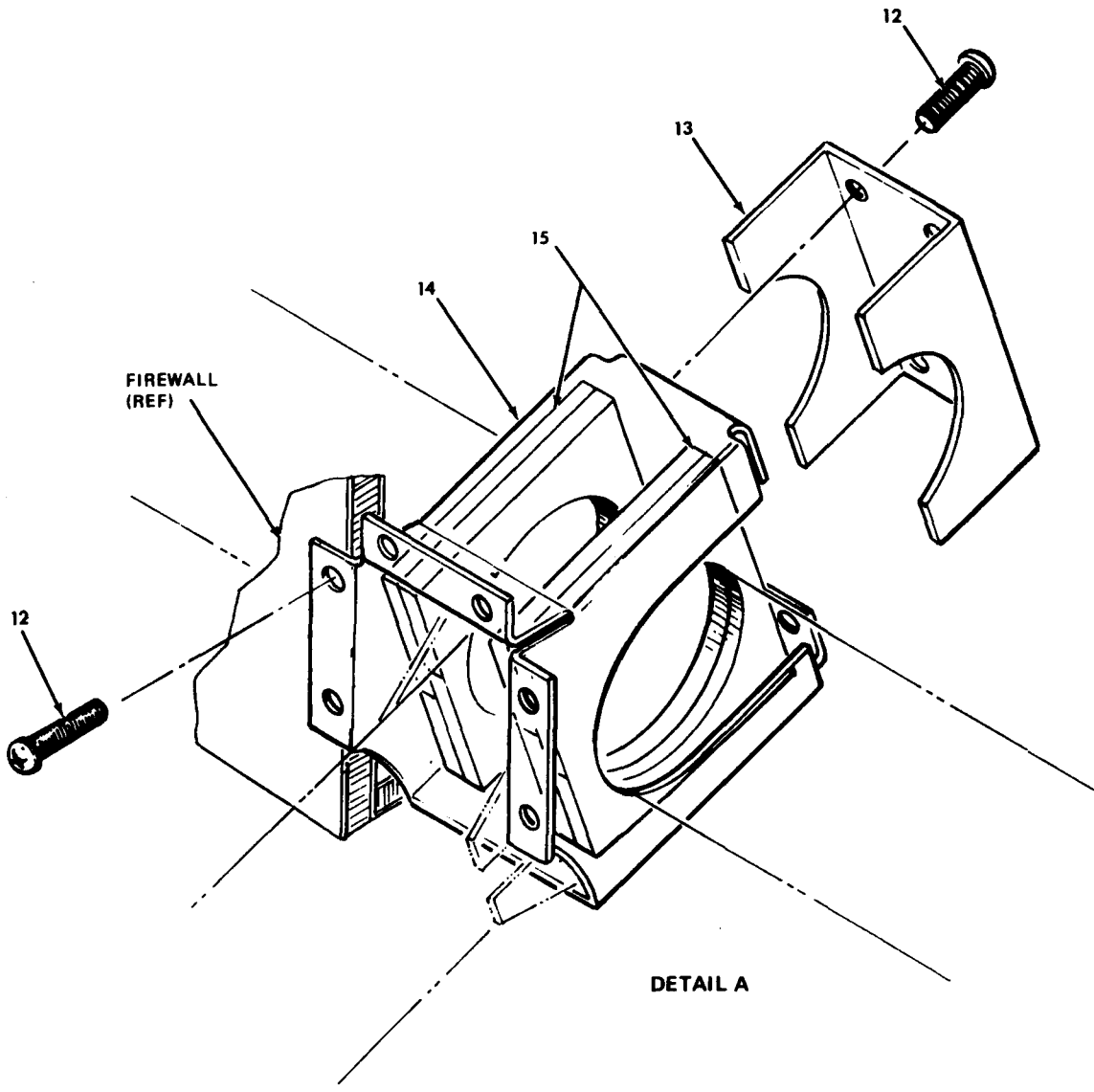

- | | |
|------------|-------------------------------|
| 1. Nut | 11. Torque Tube and Yoke Assy |
| 2. Washer | 12. Screw |
| 2A. Washer | 13. Box Cover |
| 3. Bolt | 14. Box |
| 4. Bushing | 15. Seal |
| 5. Bushing | 16. Nut |
| 6. Nut | 17. Washer |
| 7. Washer | 18. Bolt |
| 8. Bolt | 19. Bracket |
| 9. Bracket | 20. Washer |
| 10. Strut | 21. Doubler |

Nose Landing Gear Shock Absorber Installation (Sheet 2 of 2)
Figure 203

**AA-5 SERIES
MAINTENANCE MANUAL**

WHEELS AND TIRES – DESCRIPTION/OPERATION

1. General

AA-5, AA-5A, and AA-5B aircraft are equipped with 4-ply, 5.00 x 5 tube type tires on the nose landing gear. The main landing gear tires on all models are tube type, size 6.00 x 6; however, the AA-5 and AA-5A tires are 4 ply, whereas the AA-5B are 6 ply. Tires should be rotated periodically to obtain maximum tire life. All wheels are of the split-wheel design for easy servicing and each main wheel has an independent disc-type hydraulic brake system. For information and instructions covering the entire brake system, refer to 32-4-2.

All wheels and tires are balanced to within 10 inch-ounces at the factory. It is recommended that replacement tires be balanced to this specification to prevent excessive vibrations in the landing gear assemblies. Balancing is accomplished with a static bubble balancer.

WHEELS AND TIRES - MAINTENANCE PRACTICES

1. Removal/Installation of Main Gear Wheel Assemblies

A. Remove Main Gear Wheel Assembly

- (1) Support the aircraft on jacks (refer to Chapter 7).
- (2) Remove main wheel fairing if installed (refer to Paragraph 5).
- (3) Remove the two bolts (1, Figure 201) and washers (2) which attach the brake pressure plate (4) and backplate (3) to the brake cylinder assembly (5).
- (4) Remove cotter pin (1, Figure 201, Section 32-1-1), nut (2) and remove wheel assembly from axle (25).

B. Install Main Gear Wheel Assembly

- (1) Position wheel on axle (25, Figure 201, Section 32-1-1).
- (2) Check brake anchor bolts (6, Figure 201) for freedom of movement in torque plate assembly (7) and for adequate lubrication.
- (3) Install the axle nut (2, Figure 201, Section 32-1-1) and tighten until a slight drag is evident when rotating the wheel. Back off the nut to the next castellation and install the cotter pin (1).
- (4) Position brake backplate assembly (3, Figure 201) in place and install washers (2) and bolts (1). Torque mounting bolts (1) to 90 in. lb.
- (5) Install wheel fairing where applicable (refer to paragraph 5).
- (6) Remove jacks.

2. Disassembly/Reassembly of Main Gear Wheel Assemblies

A. Disassemble Main Landing Gear Wheel Assembly

- (1) Remove main landing gear wheel assembly (refer to paragraph 1, A.).
- (2) Match-mark the wheel halves and brake discs prior to disassembly to expedite reassembly in the same relative positions.

WARNING: DO NOT ATTEMPT TO SEPARATE THE WHEEL HALVES WHILE TIRE IS UNDER PRESSURE. SERIOUS INJURY COULD RESULT.

- (3) Deflate the tire by removing the valve core.
- (4) Break the tire bead loose from the wheel half assemblies.

NOTE: Care should be taken to prevent damage to the wheel halves when breaking the beads loose.

- (5) Remove nuts (8, Figure 201), washers (9), bolts (10), and separate wheel halves (11 and 12) and disc assembly (13).

AA-5 SERIES
MAINTENANCE MANUAL

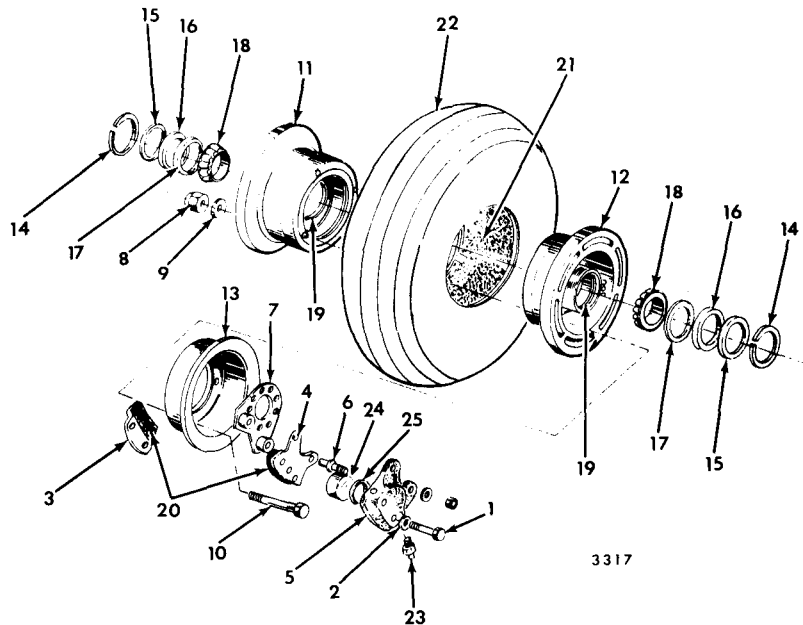

- | | |
|----------------------------|----------------------|
| 1. Bolt | 14. Snap Ring |
| 2. Washer | 15. Grease Seal Ring |
| 3. Backplate Ass'y | 16. Felt Grease Seal |
| 4. Pressure Plate Ass'y | 17. Grease Seal Ring |
| 5. Cylinder Ass'y | 18. Cone Bearing |
| 6. Anchor Bolt | 19. Bearing Cup |
| 7. Torque Plate Ass'y | 20. Brake Lining |
| 8. Nut | 21. Tube |
| 9. Washer | 22. Tire |
| 10. Bolt | 23. Bleeder |
| 11. Outer Wheel Half Ass'y | 24. Piston |
| 12. Inner Wheel Half Ass'y | 25. O-ring |
| 13. Brake Disc Ass'y | |

Main Wheel and Brake Assembly
Figure 201

AA-5 SERIES
MAINTENANCE MANUAL

- (6) Remove the snap rings (14), grease seal rings (15), felt grease seals (16), grease seal rings (17), and the cone bearings (18) from both wheel halves (11 and 12).
- (7) Inspect the bearing cups (19) for nicks and discolorations, and replace if necessary.

NOTE: To remove the bearing cups, heat the wheel halves for 15 minutes in boiling water. With an arbor press, press out the damaged bearing cups and press in the new ones while the wheel is still hot.

- (8) Clean the bearings (18), rings (15 and 17) and seals (16) with solvent and dry thoroughly using clean air blasts from an air hose. Examine bearings (18) for damage or discoloration. Repack the bearings with bearing grease per Lubrication Chart (refer to Chapter 12).
- (9) Inspect wheel halves (11 and 12) for nicks, cracks, gouges, scoring, scratches, and corrosion. Replace cracked wheel halves.
- (10) Repair minor damage by sanding area with fine sandpaper, cleaning thoroughly, applying zinc chromate primer, and painting with aluminum lacquer.
- (11) Inspect the brake disc (13) and linings (20) for excessive wear or scoring and replace if necessary. Small scratches may be sanded smooth.

B. Reassemble Main Landing Gear Wheel Assembly

- (1) Position tube (21) inside tire (22) and align the red dot on the tire with the index mark on the tube. If no mark on tube, align dot with tube seam. If no seam on tube, align dot with valve stem.
- (2) Place the outboard wheel half (11) in the tire (22) and position the valve stem through the hole.
- (3) Position the inner wheel half (12) and brake disc (13) in the tire (22) and install bolts (10), washers (9), and nuts (8).

NOTE: Care must be taken not to pinch the tube between the wheel halves.

CAUTION: IMPROPER TORQUE OF BOLTS (10) MAY RESULT IN WHEEL FAILURE.

- (4) Torque bolts (10) to 150 in. lb. Torque value may be indicated on the wheel.
- (5) Install bearings (18), grease seal rings (17), felt grease seals (16), grease seal rings (15) and snap rings (14).
- (6) Inflate the tire to the prescribed pressure given in Chapter 6, SPECIFICATIONS Paragraph.
- (7) If a new tire is installed, balance in accordance with 32-4-1, General Paragraph.

3. Removal/Installation of Nose Wheel Assembly

A. Remove Nose Wheel Assembly

- (1) Support aircraft on jacks (refer to Chapter 7).
- (2) Remove cotter pin (3, Figure 201, Section 32-2-1), nuts (4), and washers (5).
- (3) Withdraw axle rod (6) and remove nose wheel assembly from nose fork (15).
- (4) Remove plugs (7), spacers (8), and axle (9) from nose wheel assembly.

**AA-5 SERIES
MAINTENANCE MANUAL**

B. Install Nose Wheel Assembly

- (1) Assemble axle (9, Figure 201, Section 32-2-1), spacers (8), and plugs (7) in nose wheel.
- (2) Position the nose wheel in the nose fork (15) and insert axle rod (6).
- (3) Install washers (5), nuts (4), and tighten until a very slight drag is evident when the wheel is rotated. Install cotter pin (3).
- (4) Install nose wheel fairing where applicable.
- (5) Remove jacks.

4. Disassembly/Reassembly of Nose Wheel Assembly

A. Disassemble Nose Wheel Assembly

- (1) Remove nose wheel (refer to Paragraph 3. A.).

WARNING: DO NOT ATTEMPT TO SEPARATE THE WHEEL HALVES WITH THE TIRE UNDER PRESSURE. SERIOUS INJURY COULD RESULT.

- (2) Deflate the tire by removing the valve core.
- (3) Break the tire beads loose from wheel halves.

NOTE: Care should be taken to prevent damage to the wheel halves when breaking the beads loose.

- (4) Separate the wheel halves (5 and 6, Figure 202) by removing the nuts (1), washers (2 and 4) and bolts (3).
- (5) Remove the snap ring (7), grease seal rings (8), felt grease seals (9), grease seal rings (10), and cone bearings (11).
- (6) Inspect the bearing cups (12) for nicks and discoloration and replace if necessary.
NOTE: To remove the bearing cups, heat the wheel halves for 15 minutes in boiling water. With an arbor press, press out the damaged bearing cups and press in the new ones while the wheel is still hot.
- (7) Clean the bearings (11), rings (8 and 10) and seals (9) with solvent, and dry thoroughly using clean air blasts from an air hose.
- (8) Inspect the wheel halves (5 and 6) for nicks, cracks, gouges, scoring, scratches, or corrosion. Replace cracked wheel halves.
- (9) Repair minor damage by sanding area with fine sandpaper, cleaning thoroughly, applying zinc chromate primer, and painting with aluminum lacquer.
- (10) Examine bearings (11) for damage or discoloration. Replace damaged bearings. Repack bearings with specified bearing grease in lubrication chart in Chapter 12.

AA-5 SERIES
MAINTENANCE MANUAL

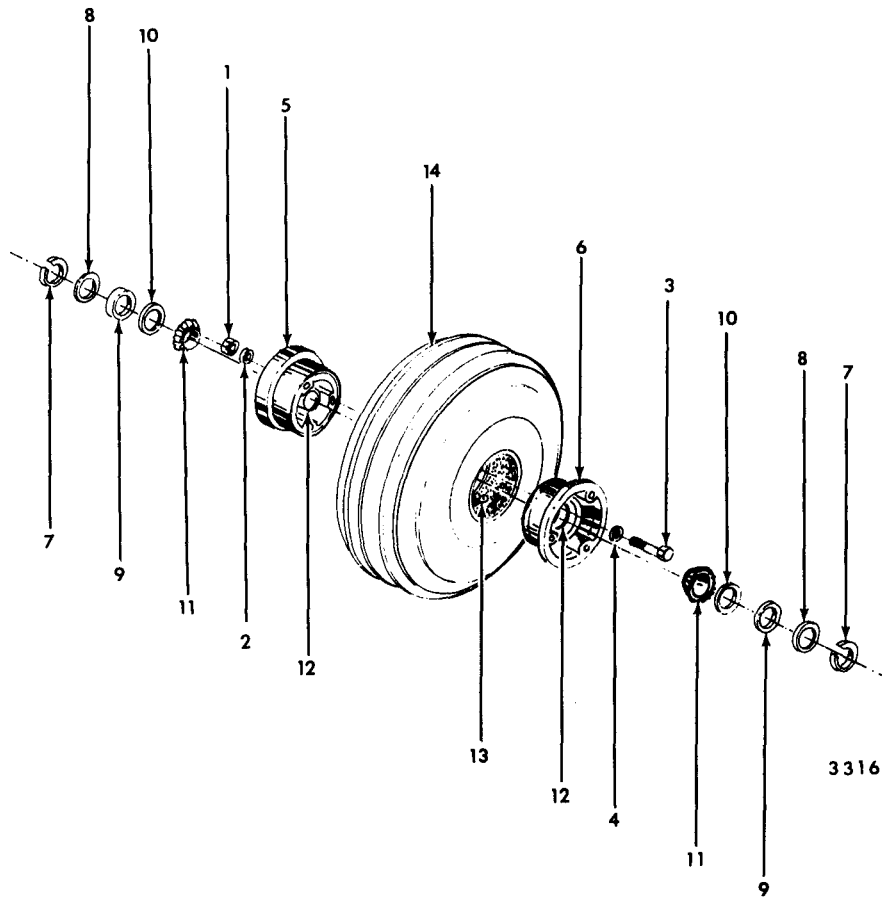

- | | |
|---------------------------|----------------------|
| 1. Nut | 8. Grease Seal Ring |
| 2. Washer | 9. Felt Grease Seal |
| 3. Bolt | 10. Grease Seal Ring |
| 4. Washer | 11. Cone Bearing |
| 5. Inner Wheel Half Ass'y | 12. Bearing Cup |
| 6. Outer Wheel Half Ass'y | 13. Tube |
| 7. Snap Ring | 14. Tire |

Nose Wheel Assembly
Figure 202

**AA-5 SERIES
MAINTENANCE MANUAL**

B. Reassemble Nose Wheel Assembly

- (1) Position the tube (13) inside the tire (14), aligning the red dot on the tire with the index mark on the tube. If no mark on tube, align dot with tube seam. If no seam, align dot with valve stem.
- (2) Position the tire and tube on the wheel half (6) and insert the valve stem through the hole.
- (3) Position the other wheel half (5) in tire (14) and install washers (4), bolts (3), washers (2) and nuts (1).

NOTE: Care should be taken not to pinch the tube between the wheel halves.

- (4) If a new tire is installed, balance in accordance with 32-4-1, General paragraph.

CAUTION: IMPROPER TORQUE OF BOLTS (3) MAY RESULT IN WHEEL FAILURE.

- (5) Torque the bolts (3) to 90 in. lb. Torque value may be indicated on the wheel.
- (6) Install the bearings (11), grease seal rings (10), felt grease seal (9), grease seal rings (8), and snap ring (7).
- (7) Inflate the tire to the prescribed pressure given in Chapter 6.
- (8) Install nose wheel assembly (refer to paragraph 3. B.).
- (9) Remove jacks.

5. Removal/Installation of Main Wheel Fairing Assembly

A. Remove Wheel Fairing Assembly (See Figure 203.)

NOTE: AA-5, Serial No. 0641 and Subsequent, AA-5A and AA-5B aircraft having wheel fairing installed is also equipped with a streamlining fairing. The streamlining fairing must be removed to gain access to wheel fairing attaching hardware.

- (1) Remove screws (1), washers (2), and slide streamlining fairing (3) up the strut.
- (2) Remove plug button (4), bolts (5), washers (6), and bearing (7).
- (3) On AA-5 aircraft, remove bolt (8), washers (9), and tilt fairing up so that bracket (10) will clear flex bolt (11), and remove fairing shell assembly (12).

NOTE: On AA-5A and AA-5B aircraft, bracket (10) has been replaced by a flat plate bolted directly to the fairing shell assembly (12) and has a cutout that fits over the end of flex bolt (11).

- (4) On AA-5A and AA-5B aircraft, remove nut (13) and washer (14) from flex bolt (11), tilt fairing to clear flex bolt (11), and remove fairing shell assembly (12).

B. Install Main Wheel Fairing Assembly (See Figure 203.)

- (1) Position fairing shell assembly (12) in place on wheel with flex bolt (11) in bracket (10) on AA-5, and install washers (9) and bolts (8). On AA-5A and AA-5B, position flex bolt (11) end through flat plate on fairing and install washer (14) and nut (13).
- (2) Install bearing (7), washers (6), bolts (5), and plug button (4).
- (3) Position streamlining fairing (3) in place and install washers (2) and screws (1).
- (4) Check position of scraper (15) in relation to tire, and if necessary adjust scraper for 1/2-inch clearance.

6. Removal/Installation of Nose Wheel Fairing Assembly

A. Remove Nose Wheel Fairing Assembly (See Figure 204).

- (1) Remove plug buttons (1) from both sides of fairing.
- (2) Remove tow bar bolts and spacers.
- (3) Remove nose wheel and fork assembly (refer to paragraph 1).
- (4) Remove bolts (2, Figure 204), washers (3), and fairing (4).

B. Install Nose Wheel Fairing Assembly (See Figure 204).

- (1) Position fairing (4, Figure 204) onto nose strut.
- (2) Install nose fork assembly (refer to 32-4-1, paragraph 1).
- (3) Position fairing in place on nose fork assembly and install washers (3) and bolts (2).
- (4) Install tow bar bolts and spacers.
- (5) Install plug buttons (1) on both sides of fairing.
- (6) Check position of scraper (5, Figure 204) in relation to tire, and if necessary adjust scraper for 1/2 inch clearance from tire.

7. Main Landing Gear Wheel Alignment

Toe-in adjustments are made at the factory within the tolerances specified in Figure 205 and the toe-in adjustment should be checked periodically to ensure the wheels are properly aligned. Setting toe-in within the specified tolerances while the cabin and fuel tanks are empty will give approximately zero toe-in at gross weight. Ideal setting is zero toe-in at normal operating weight. Therefore, if normally operated at less than gross weight and abnormal tire wear occurs, the wheel alignment should be adjusted to obtain the ideal setting for the load conditions under which the aircraft normally operates. At wheel alignment the desired procedure is to use the least number of shims possible to obtain the specified tolerances. Shims are available from the factory under the following part numbers.

| <u>PART NUMBER</u> | <u>SHIM ANGLE</u> | <u>AMOUNT OF TOW-IN OUT CHANGE</u> |
|--------------------|-------------------|------------------------------------|
| 701068-1 | 0° -30 min. Ref. | 15 minutes |
| 701068-2 | 0° -45 min. Ref. | 23 minutes |
| 701068-3 | 1° -0 min. Ref. | 30 minutes |

NOTE: The use of toe-in adjustment shims requires the replacement of two AN6-22A bolts with longer AN6-23A bolts on the thick side of the shim.

AA-5 SERIES
MAINTENANCE MANUAL

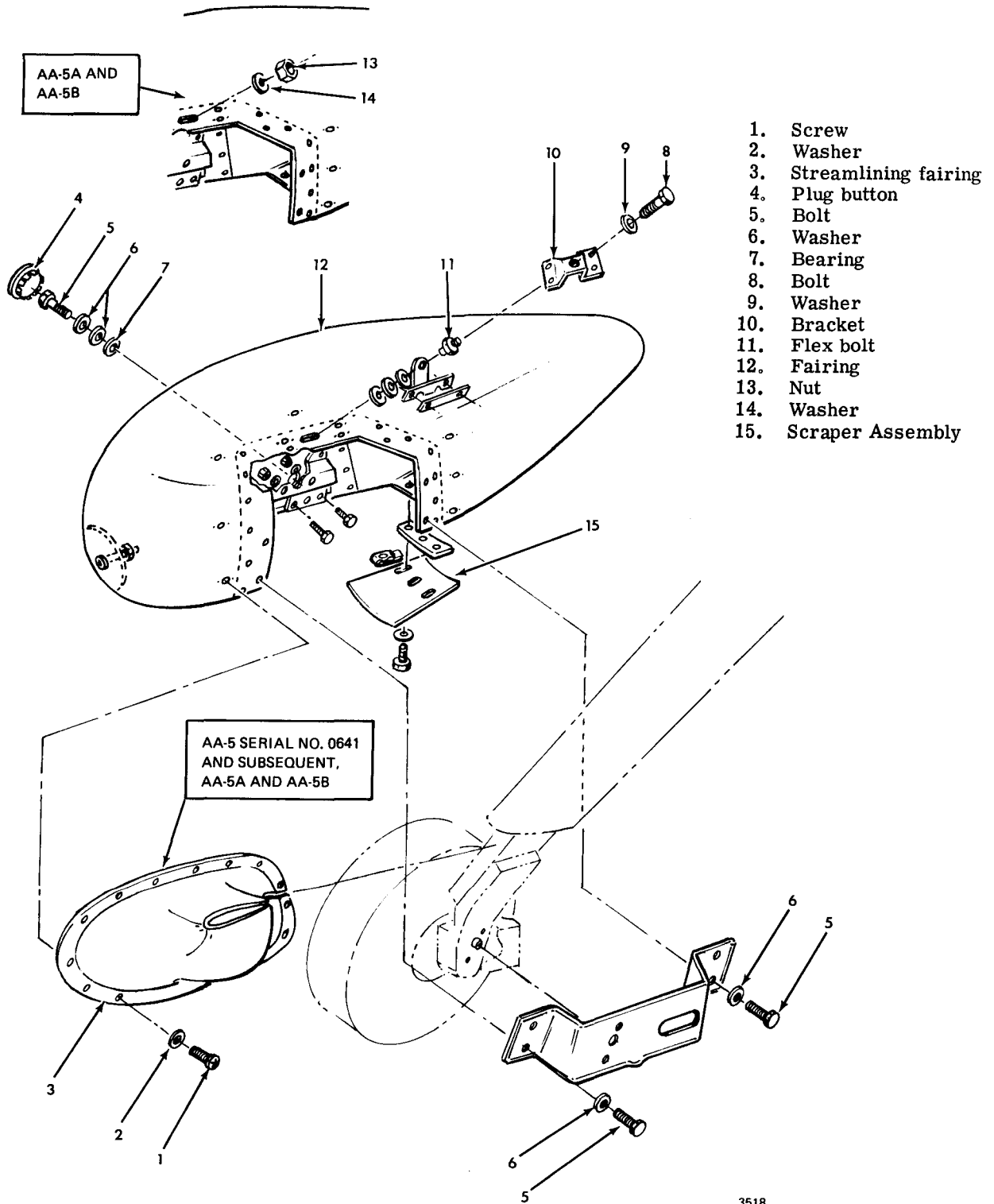

1. Screw
2. Washer
3. Streamlining fairing
4. Plug button
5. Bolt
6. Washer
7. Bearing
8. Bolt
9. Washer
10. Bracket
11. Flex bolt
12. Fairing
13. Nut
14. Washer
15. Scraper Assembly

Main Wheel Fairing Assembly
Figure 203

3518

AA-5 SERIES
MAINTENANCE MANUAL

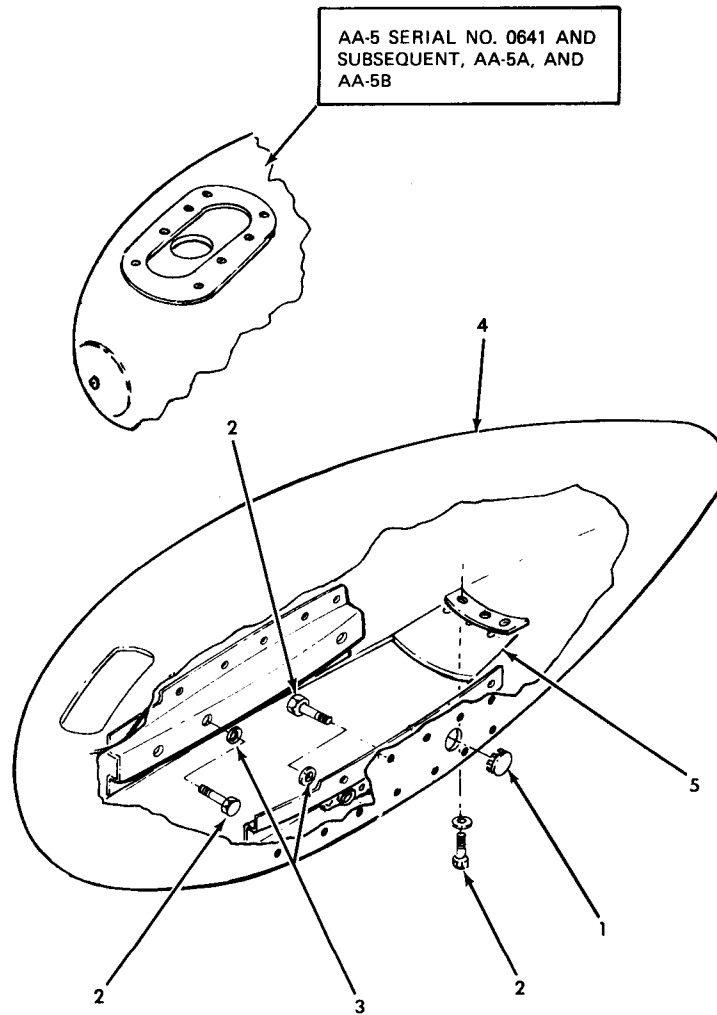

3319

1. Plug button
2. Bolt
3. Washer
4. Fairing
5. Scraper

Nose Wheel Fairing Assembly
Figure 204

AA-5 SERIES
MAINTENANCE MANUAL

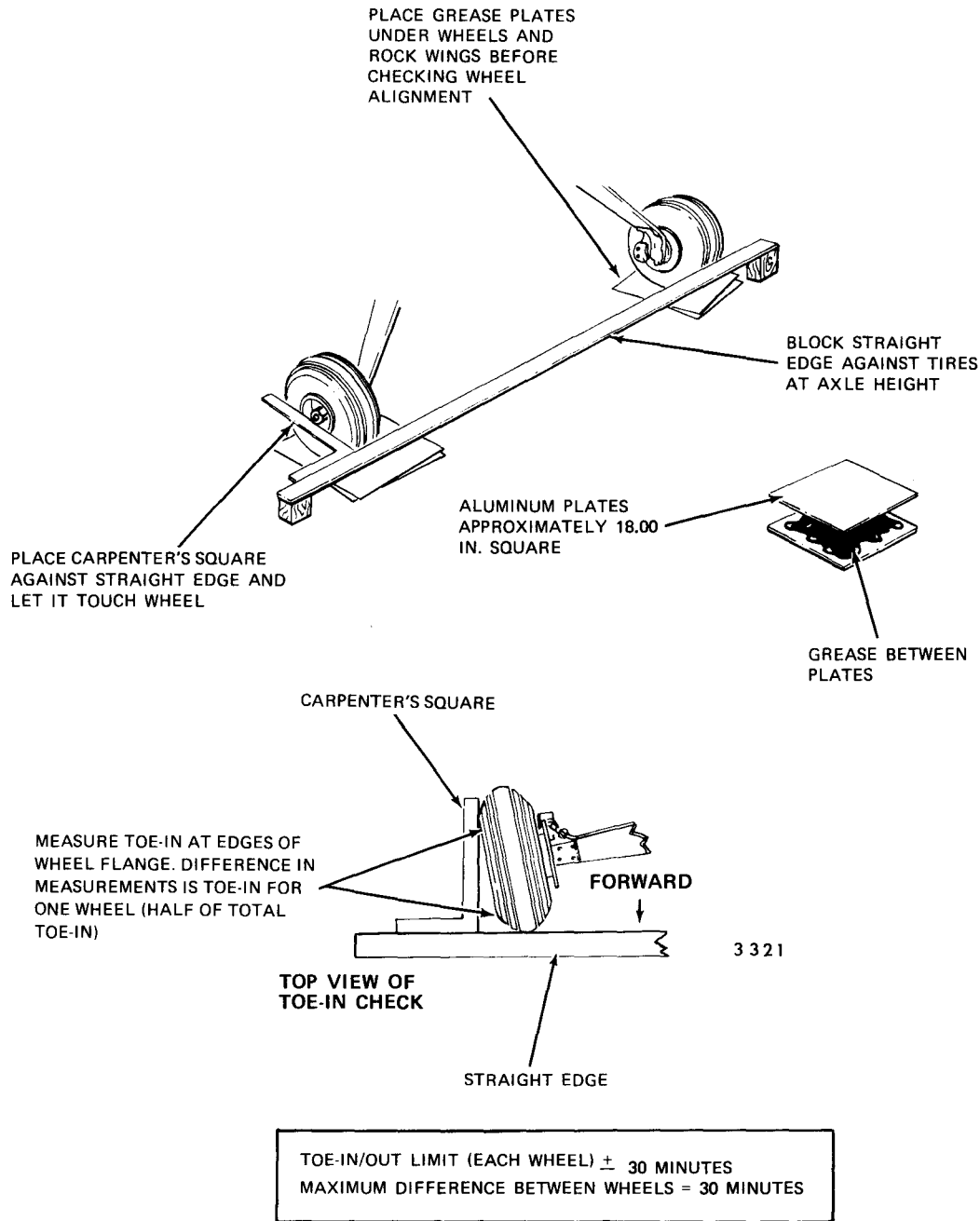

Wheel Alignment Procedure
Figure 205

**AA-5 SERIES
MAINTENANCE MANUAL**

BRAKES — DESCRIPTION/OPERATION

1. General

The aircraft utilizes hydraulic brakes on each main landing gear. The brakes are controlled by the rudder pedals.

The hydraulic brake system consists of the wheel brake assemblies, two master cylinders for the single brake system, four master cylinders for the dual brake system, and a parking brake assembly. The wheel brake assemblies use a disc which is attached to the main wheel thru-bolts. The floating brake assembly is attached to the inside of the axle assembly.

The optional dual hydraulic brake system used on the AA-5, AA-5A, and AA-5B is unique in the fact it requires no additional reservoir. The system is designed for dual operation and incorporates two types of master cylinders. Pressure applied to the left master cylinder (1, Figure 1) passes through an integral piston by-pass port in the right master cylinder (3) closes the port and applies pressure to the left wheel assembly. If pressure is applied to both cylinders simultaneously, the force from the left cylinder is applied to the top of the piston in the right cylinder, nearly doubling the pressure at the wheel brake assembly. Master cylinders (2) and (4) operate in the same manner.

When the brake pedals for master cylinders (3) and (4) are in neutral position, the ports are open for direct flow to the brake assemblies from cylinders (1) and (2).

The standard single brake system does not use cylinders (3) and (4). However, operation is essentially the same as above, except master cylinders (1) and (2) supply hydraulic pressure directly to the wheel brake assemblies.

On aircraft AA5-0001 through 0834, AA5A-0001 through 0522, and AA5B-0001 through 0692 (see Figure 1.), the optional parking brake system consists of a parking brake control attached by chains and linkage to locking levers on the master brake cylinder shafts. The parking brakes are applied by depressing both the toe brakes on the pilot's side, then pulling out the parking brake control. The locking levers then hold the brakes in the applied position. Brake release is accomplished by depressing both toe brakes on the pilot's side and simultaneously pushing in the parking brake control to release the locks.

On aircraft AA5A-0523 and subsequent and AA5B-0693 and subsequent (See Figure 2.), the parking brake system consists of a parking brake control which operates a dual in-line valve between the brake cylinders and the respective wheel brakes. The parking brakes are applied by pulling the parking brake control out to the stops and depressing both toe brakes at either station. Brake release is accomplished by pushing the control all the way in.

2. Special Tools

When disassembling the hydraulic brake master cylinders, special type pliers are required to remove the Truarc snap ring. A separate size pliers will be needed for the reservoir type cylinder and for the non-reservoir type cylinder. Pliers may be purchased locally or ordered from Waldes Kohinor, Inc., Long Island City, New York. The types of pliers required are:

Truarc Snap Ring Pliers No. 3

Truarc Snap Ring Pliers No. 1120

**AA-5 SERIES
MAINTENANCE MANUAL**

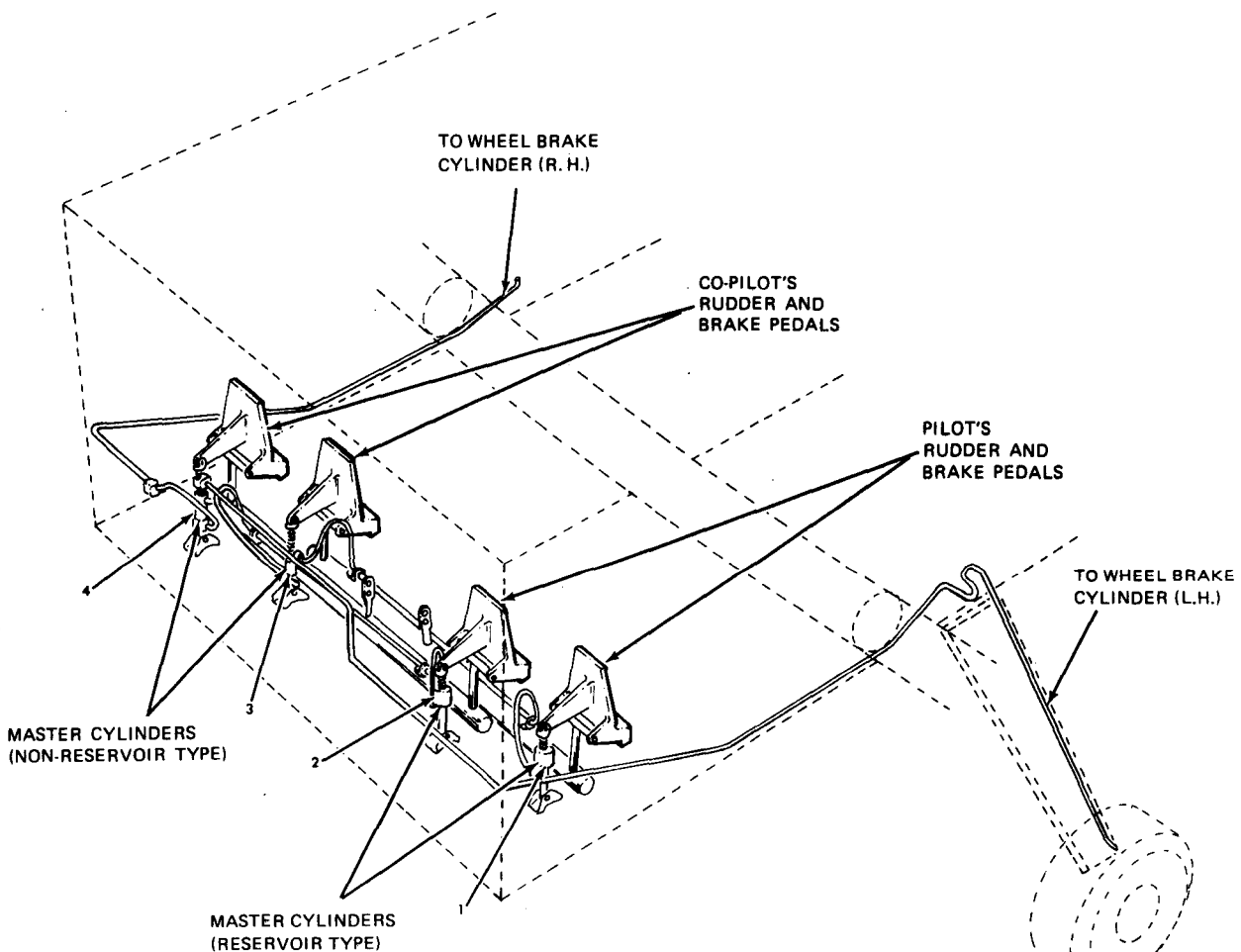
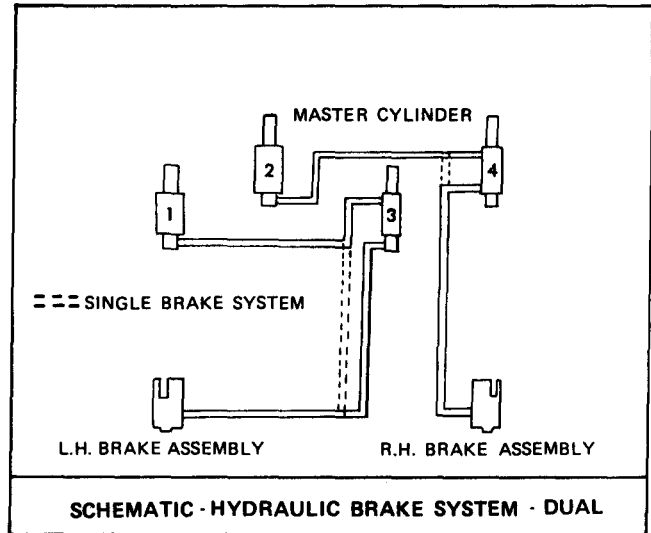

Hydraulic Brake System
AA5-0001 through 0834
AA5A-0001 through 0522
AA5B-0001 through 0692
Figure 1

3323

**AA-5 SERIES
MAINTENANCE MANUAL**

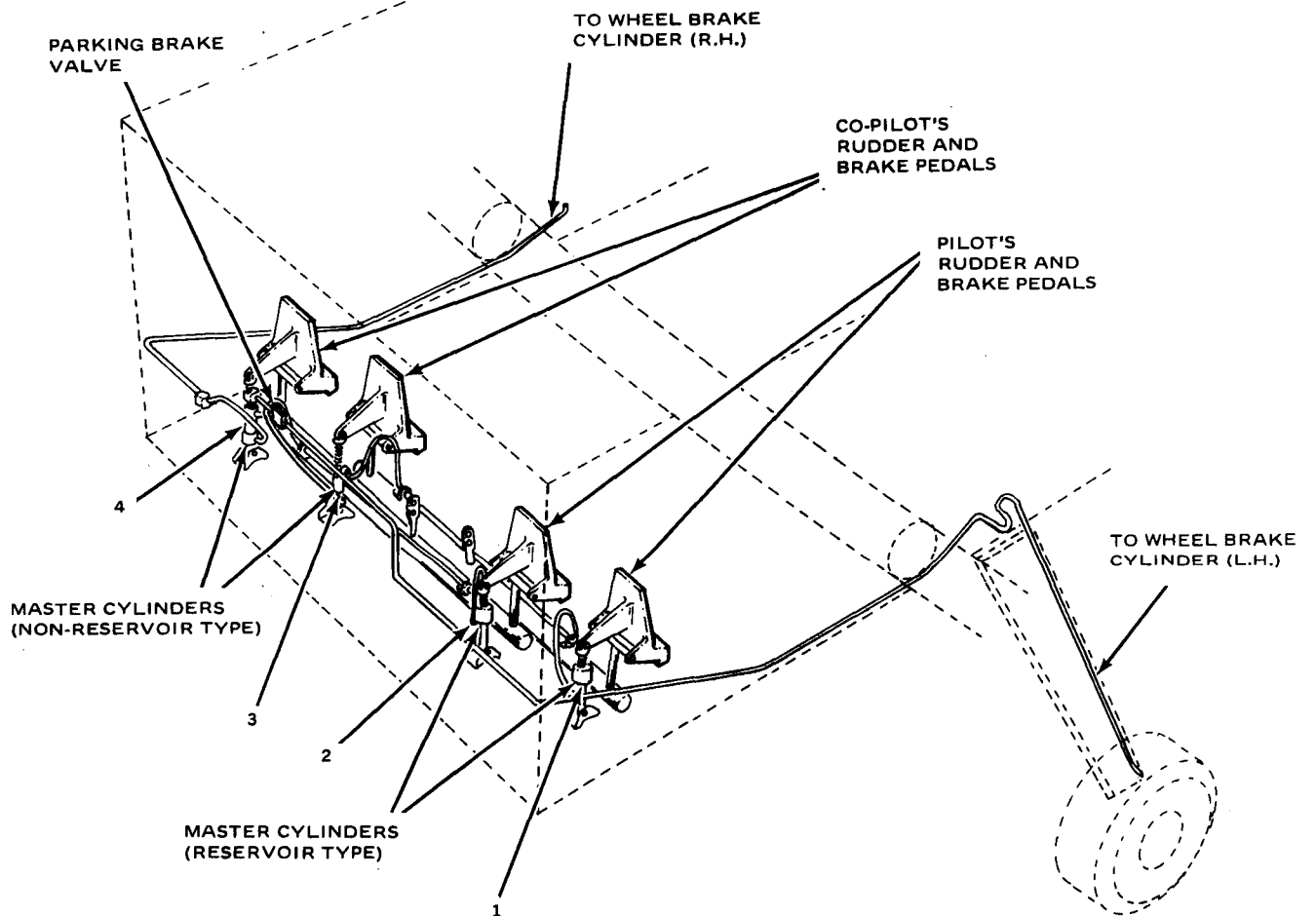
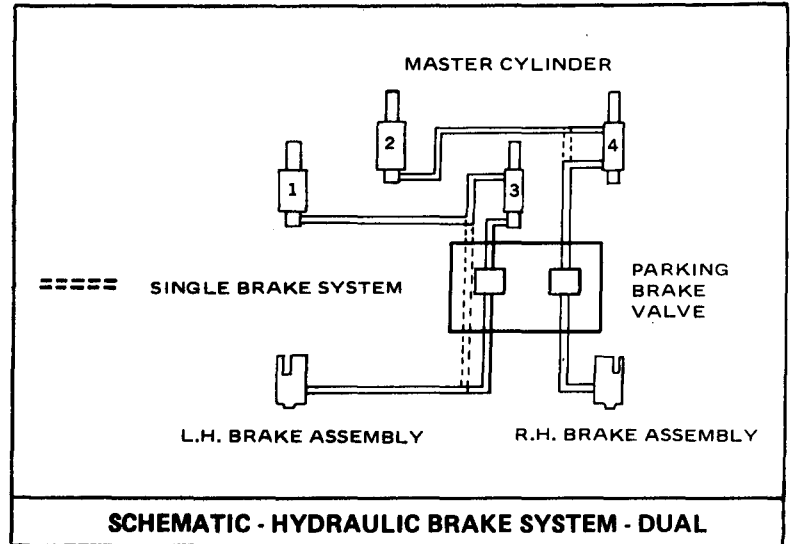

**Hydraulic Brake System
(AA5A-0523 and Subsequent)
(AA5B-0693 and Subsequent)
Figure 2**

BRAKES - MAINTENANCE PRACTICES

1. Removal/Installation of Master Cylinder

A. Remove Master Cylinder

- (1) Bleed the fluid from the brake system by removing the bleeder valve in the bottom of the brake assembly.
- (2) Disconnect the flexible hose assembly at the master cylinder connection.
- (3) Remove the cotter pin and withdraw the clevis pin which connects the clevis on the master cylinder to the rudder pedal.
- (4) Remove the cotter pin and withdraw the clevis pin which attaches the mounting lug of the master cylinder to the mounting bracket.
- (5) Disconnect parking brake chain from lever on master cylinder by cutting safety wire at chain to lever attachment.

B. Install Master Cylinder

- (1) Position master cylinder to mounting bracket and install clevis pin and cotter pin.
- (2) Position master cylinder clevis to rudder pedal connection and install clevis pin and cotter pin.
- (3) Connect the flexible hose assembly to the master cylinder connection.
- (4) Connect parking brake chain to parking brake lever on master cylinder with 0.032 inch stainless steel safety wire.
- (5) Service hydraulic brake system with an approved hydraulic fluid conforming to MIL-H-5606. (See Chapter 12.)

2. Disassembly/Reassembly of Master Cylinder - Non-Reservoir Type

A. Disassemble Master Cylinder (See Figure 201.)

- (1) Remove fittings from cylinder inlet and outlet ports.
- (2) Remove clevis (1) and check nut (2) from shaft (3). Note distance from mounting hole in clevis (1) and mounting hole in brake cylinder housing (16) before removing clevis (1). This distance must be maintained upon reassembly.
- (3) Remove snap ring (4) using special pliers, Truarc No. 1120.
- (4) Remove the end cap (6).
- (5) Remove piston and shaft assembly from housing (16). To disassemble piston (12) from shaft (3) remove snap ring (14) and spring (13).

NOTE: Do not attempt to remove the thrust collar from shaft (3). These parts are pressed together. If either is faulty, replace both.

- (6) Remove snap ring (8).

AA-5 SERIES
MAINTENANCE MANUAL

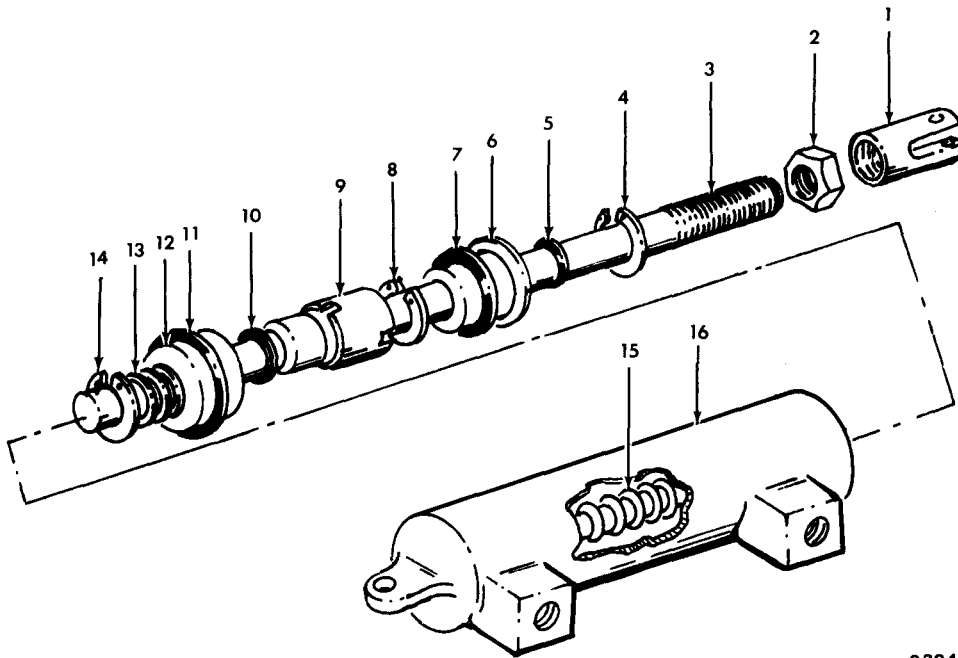

3324

- | | | |
|------------------------|--------------|---------------|
| 1. Clevis | 7. O-ring | 13. Spring |
| 2. Nut | 8. Snap Ring | 14. Snap Ring |
| 3. Shaft Assembly | 9. Spacer | 15. Spring |
| 4. Snap Ring | 10. O-ring | 16. Housing |
| 5. O-ring | 11. O-ring | |
| 6. End Cap and Bearing | 12. Piston | |

Master Cylinder - Non-Reservoir Type
Figure 201

B. Reassemble Master Cylinder (See Figure 201.)

NOTE: Use new O-rings at reassembly of master cylinder.

- (1) Immediately before reassembly, immerse all seals in hydraulic brake fluid, MIL-H-5606, (See Chapter 12.) and apply a coating of brake fluid to bore of housing (16).
- (2) Assemble O-rings (10 and 11), spacer (9), piston (12), and spring (13) in place on shaft (3) and lock together by installing snap rings (8 and 14).
- (3) Assemble O-rings (5 and 7) and end cap (6) on shaft (3).
- (4) Engage bottom of shaft and piston assembly into small diameter of spring (15) and install into housing (16). Use caution when installing into housing and do not damage O-ring seals.
- (5) Depress shaft assembly and lock into position with snap ring (4).
- (6) Install check nut (2) and clevis (1) and adjust to dimensions that were checked before disassembly.

CAUTION: DO NOT OVERTIGHTEN FITTINGS IN MASTER CYLINDER PORTS. OVERTIGHTENING COULD CRACK THE CASTING.

- (7) Install fittings in master cylinder inlet and outlet ports.

3. Disassembly/Reassembly of Master Cylinder — Reservoir Type

NOTE: Items 3, 4, 5, and 6 of Figure 202 are not installed in master cylinders on those aircraft with hydraulic parking brake valve system installed.

A. Disassemble Master Cylinder (See Figure 202.)

- (1) Remove fitting from cylinder housing outlet port.
- (2) Remove clevis (1), check nut (2), and spring (3) from shaft (18). Note distance from mounting hole in clevis and mounting hole in brake housing (19) before removing clevis. This distance must be maintained upon reassembly.
- (3) Remove bolt (4), parking brake lever (5), and spacer (6).
- (4) Remove filler plug (7).
- (5) Remove snap ring (8) using special pliers, Truarc No. 3, and remove cover plate (9) and rubber seal (10).
- (6) Use a 1/8-inch allen wrench and remove screw (11) and washer (12).
- (7) Remove piston (15) and shaft assembly from housing (19).
- (8) Remove snap ring (13), spring (14), piston (15), and O-rings (16 and 17) from shaft (18).

NOTE: Do not attempt to remove the thrust collar from shaft (18). These parts are pressed together. If either is faulty, replace both. Do not attempt to remove the bushing from cover plate (9). These parts are swaged together and should be ordered as a unit if either is defective.

**AA-5 SERIES
MAINTENANCE MANUAL**

B. Reassemble Master Cylinder

NOTE: Use new O-rings at reassembly of master cylinder.

- (1) Immediately before reassembly, immerse all seals except (10) in hydraulic fluid (MIL-H-5606, see Chapter 12) and apply a coating of hydraulic fluid to the bore of the cylinder housing (19).
- (2) Assemble O-rings (17 and 16), piston (15), spring (14), on shaft (18), and lock in place with snap ring (13).
- (3) Engage bottom of shaft and piston assembly into small diameter of spring (20) and install assembly into housing (19).

NOTE: Use a new screw (11) and washer (12) and snap ring (8) at master cylinder reassembly.

- (4) Depress shaft assembly into housing (19) and lock in position with screw (11) and washer (12).
- (5) Install rubber seal (10), cover plate (9), and lock in place with snap ring (8).
- (6) Install filler plug (7).
- (7) Slide parking brake lever (5) onto shaft (18) and position spacer (6) in place under lever, and secure with bolt (4).
- (8) Install spring (3), nut (2), and clevis (1) on shaft (18). Adjust clevis (1) to dimension noted before disassembly.
- (9) Install fitting cylinder housing outlet port.

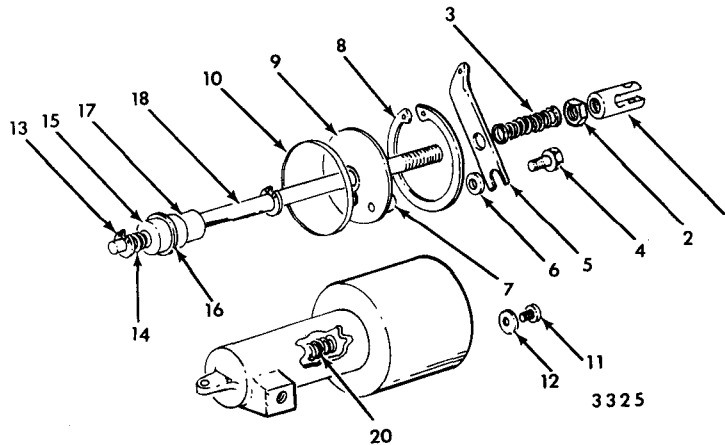

- | | | |
|------------------------|----------------------|----------------------|
| 1. Clevis | 8. Snap Ring | 15. Piston |
| 2. Lock Nut | 9. Cover Plate Ass'y | 16. O-Ring |
| 3. Spring | 10. Rubber Seal | 17. O-Ring |
| 4. Bolt | 11. Screw | 18. Shaft |
| 5. Parking Brake Lever | 12. Washer | 19. Cylinder Housing |
| 6. Spacer | 13. Snap Ring | 20. Spring |
| 7. Filler Plug | 14. Spring | |

Master Cylinder - Reservoir Type
Figure 202

4. Removal/Installation of Wheel Brake Assemblies

A. Remove Wheel Brake Assembly (See Figure 203.)

NOTE: The brake disc (11, Figure 203) is removed after wheel removal and disassembly. Torque plate assembly (12) can be removed after wheel has been removed.

- (1) Disconnect hydraulic line at wheel brake assembly fitting.
- (2) Remove bolts (1), washers (2), and remove backplate (3).
- (3) Pull anchor bolts (10) out of torque plate assembly (12) and remove brake cylinder assembly (4).
- (4) Slide pressure plate (5) off anchor bolts.
- (5) Blow lightly with compressed air into hydraulic line fitting to force piston (6) from cylinder (4). Slide O-ring (7) off piston (6).
- (6) Remove nuts (8), washers (9), and anchor bolts (10).

B. Install Wheel Brake Assembly

NOTE: Keep brake lining (13) dry and completely free from hydraulic fluid. Install new O-ring (7) at reassembly.

- (1) Lubricate piston (6), cylinder bore, and O-ring (7) with clean hydraulic fluid.
- (2) Assemble anchor bolts (10) into cylinder (4) and install washers (9) and nuts (8).
- (3) Assemble O-ring (7) on piston (6) and install in cylinder (4). Hold piston in cylinder until pressure plate (5) is installed.
- (4) Slide pressure plate (5) onto anchor bolts (10).
- (5) Insert anchor bolts (10) into torque plate assembly (12), and install washers (2), bolts (1), and backplate (3). Torque bolts (1) to 75-90 in. lb.

5. Bleeding Hydraulic Brake System

A. Bleed Hydraulic Brake System

NOTE: When servicing the hydraulic brake system, use an approved hydraulic fluid conforming to MIL-H-5606 (see Chapter 12).

NOTE: The following procedure is applicable to both single and dual brake installations.

- (1) Remove the vent plugs from master cylinders (1 and 2, Figure 1, subsection 32-4-2) and replace with overflow lines. Immerse the free ends of the overflow lines in a can containing enough hydraulic fluid to cover the ends of the lines.
- (2) Connect a clean hydraulic pressure source to the brake assembly bleeder valve (11, Figure 202).

AA-5 SERIES
MAINTENANCE MANUAL

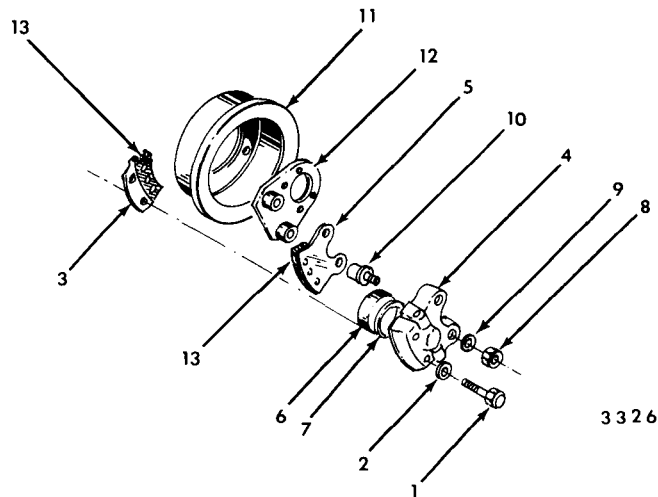

- | | |
|-------------------|------------------|
| 1. Bolt | 8. Nut |
| 2. Washer | 9. Washer |
| 3. Backplate | 10. Anchor Bolt |
| 4. Cylinder | 11. Brake Disc |
| 5. Pressure Plate | 12. Torque Plate |
| 6. Piston | 13. Lining |
| 7. O-ring | |

Wheel Brake Assembly
Figure 203

- (3) Fill the system until the overflow line in the master cylinder being filled shows no more air bubbles. Remove the overflow lines.
- (4) Remove the source of fluid and pressure and allow the fluid to drain back through the system until the fluid level is approximately 1/4 inch from the top of the reservoir in the master cylinder.
- (5) Secure the bleeder valve and replace the vent plugs.

NOTE: Do not fill the reservoir higher than 1/4 inch from the top as this will result in spillage. If fluid is accidentally spilled on the rug, it can be removed with Imperial cleaner.

6. Cleaning Brake System Parts

WARNING: USE SOLVENTS IN A WELL VENTILATED AREA. AVOID BREATHING FUMES.
KEEP AWAY FROM FLAMES.

Clean all parts except brake linings with cleaning solvents, Federal Specification No. P-S-661 (see Chapter 12). Thorough cleaning is important to prevent brake malfunction.

7. Inspection of Brake System Parts

A. Inspect Brake Cylinders

NOTE: Any part damaged or worn beyond minor repair must be replaced.

**AA-5 SERIES
MAINTENANCE MANUAL**

- (1) After disassembly of brake cylinders inspect all parts for wear, cracks, damage, or distortion.
- (2) Check piston for deep scratches.
- (3) Check bore on cylinder housing for deep scratches.
- (4) Check valve spring (13, Figure 201) for a free length of 3/8 to 7/16 inch.
- (5) Check return spring (15, Figure 201) for a free length of 2-15/16 to 3-1/16 inches.
- (6) Check valve spring (14, Figure 202) for a free length of 3/8 to 7/16 inch.
- (7) Check return spring (20, Figure 202) for a free length 2-3/8 to 2-1/2 inches.
- (8) Inspect brake linings for damage, deterioration, and excessive wear. New brake linings should be installed when linings are worn to less than 1/10 inch.
- (9) Inspect anchor bolts on wheel brake assembly for nicks or damage and sand smooth with fine sandpaper.
- (10) Inspect wheel brake disc for a minimum thickness of 0.205 inch. If brake disc is below minimum thickness, install a new brake disc.

8. Testing Brake Master Cylinders

A. Test Brake Master Cylinder - Non-Reservoir Type

- (1) After complete assembly, blow air through bottom port hole in cylinder housing (16, Figure 201) and observe air passing out through top port. This assures that the valve is opening. With air still passing through port, depress shaft approximately 1/16 inch. This should cut off air passing through the assembly and out the top port and show that the check valve is closing and sealing properly.
- (2) The following function and proof test should be conducted with hydraulic brake fluid (MIL-H-5606, see Chapter 12) only.
- (3) Bleed all air from system and pressurize cylinder to 1500 psi. Allow 2 minutes for stabilization and check for external leaks.
- (4) Lower pressure to 1000 psi and after a 2-minute stabilization period, check pressure drop. Pressure should remain steady. A 40 psi drop in a 2-minute period is acceptable.
- (5) If cylinder fails to pass the above test, recycle and check again.
- (6) If cylinder still fails test, disassemble and check the O-ring seal (11) for cuts or scratches which might have occurred during assembly. Also check for dirt or contamination around O-ring (11) and O-ring (5).

B. Test Brake Master Cylinder - Reservoir Type

- (1) After complete assembly, blow air through port hole in cylinder housing (19, Figure 202) and observe air passing out through vent in filler plug (7). With air still passing through port, depress shaft approximately 1/16 inch. This should cut off air passing through the assembly and out vent in filler plug (7), and show that check valve is closing and sealing properly.

AA-5 SERIES
MAINTENANCE MANUAL

- (2) The following function and proof test should be conducted with hydraulic brake fluid, MIL-H-5606, only. see chapter 12.
- (3) Bleed all air from system and pressurize cylinder to 1500 psi. Allow 2 minutes for stabilization and check for external leaks.
- (4) Lower pressure to 1000 psi and after a 2-minute stabilization period, check pressure drop. Pressure should remain steady. A 40 psi drop in a 2-minute period is acceptable.
- (5) If cylinder fails to pass the above test, recycle and check again.
- (6) If cylinder still fails test, disassemble and check the O-ring (16) for cuts or scratches which might have occurred during assembly. Also check for dirt or contamination around O-ring (16) and O-ring (17).

9. Rigging the Parking Brake

A. Aircraft AA5-0001 through 0834, AA5A-0001 through 0522, and AA5B-0001 through 0692 (See Figure 204.)

- (1) Place the parking brake control in the OFF position (full in) and measure the dimension at (A). This dimension should be 1.75 ± 0.13 inches. If necessary, adjust the wire stop to obtain this dimension.
- (2) The actuating chain should exert a straight pull on the parking brake levers. The master cylinder cover plate and lever may be rotated to achieve this condition.
- (3) Allow the rudder pedals to center and begin pulling out the parking brake control until all slack is removed from the actuating chain.
- (4) Measure the dimension at (B). This dimension should be 0.5 ± 0.13 inch. If this dimension is less than specified, remove enough chain to obtain 0.5 ± 0.13 inch; if this dimension is greater than specified, the chain length will have to be increased.
- (5) Check the parking brake for proper operation. After disengaging, apply full rudder pedal deflection in each direction and ensure that neither master cylinder parking brake lever is lifting.

B. Aircraft AA5A-0523 and Subsequent, AA5B-0693 and Subsequent (See Figure 205.)

- (1) If not previously accomplished, bleed and service brake system (Paragraph 5 above).
- (2) Install the wire through the cable stop on the lever but do not tighten. Push the parking brake control in as far as it will go.
- (3) Push the lever on the valve to the up stop. Tighten the wire stop securely.
- (4) Position the outer cable housing as shown and tighten clamp hardware. Pull the parking brake control until the lever contacts the cable housing. The control travel should be 1.5 ± 0.25 inches. Readjust cable housing position as required.
- (5) With the control out as far as it will go, press both toe brakes in as far as they will go and release them. Both main landing gear wheels should be locked.
- (6) Push the parking brake control in as far as it will go. Both main landing gear wheels should turn freely.
- (7) Bend the end of the wire beyond the wire stop as shown in Figure 205.

AA-5 SERIES
MAINTENANCE MANUAL

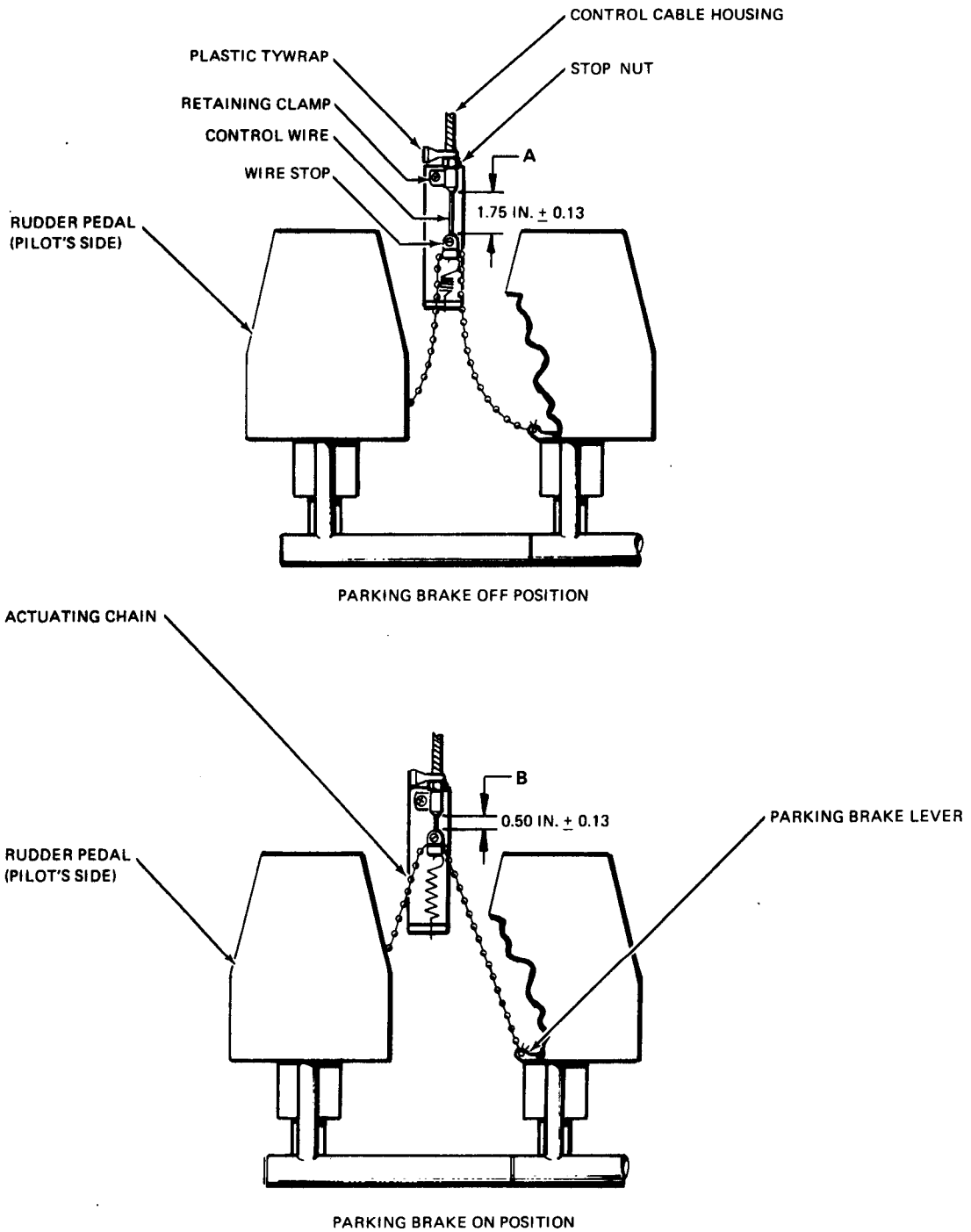

Parking Brake Rigging
AA5-0001 thru 0834
AA5A-0001 thru 0522
AA5B-0001 thru 0692
Figure 204

10. Relining Brakes

A. Reline Brakes (See Figure 203).

- (1) Remove wheel brake assembly (refer to Paragraph 4).
- (2) Place backplate (3) on a table with lining side down flat. Center a 9/64-inch (or slightly smaller) punch in the rolled rivet and hit the punch sharply with a hammer. Punch out all rivets securing the linings to the backplate and pressure plate (5) in the same manner.

NOTE: A rivet relining kit, Part No. 199-00100, is available from Grumman American Aviation Corporation. This kit consists of an anvil and punch.

- (3) Clamp the flat side of the anvil in a vise.
- (4) Align new lining on back plate and place brake rivet in hole with rivet head in the lining. Place the rivet head against the anvil.
- (5) Center the rivet setting punch on the lips of the rivet. While holding the back plate down firmly against the lining, hit the punch with a hammer to set the rivet. Repeat blows on the punch until lining is firmly against the back plate.
- (6) Realign the lining on the backplate and install rivets in the remaining holes.
- (7) Install a new lining on pressure plate in the same manner.

AA-5 SERIES
MAINTENANCE MANUAL

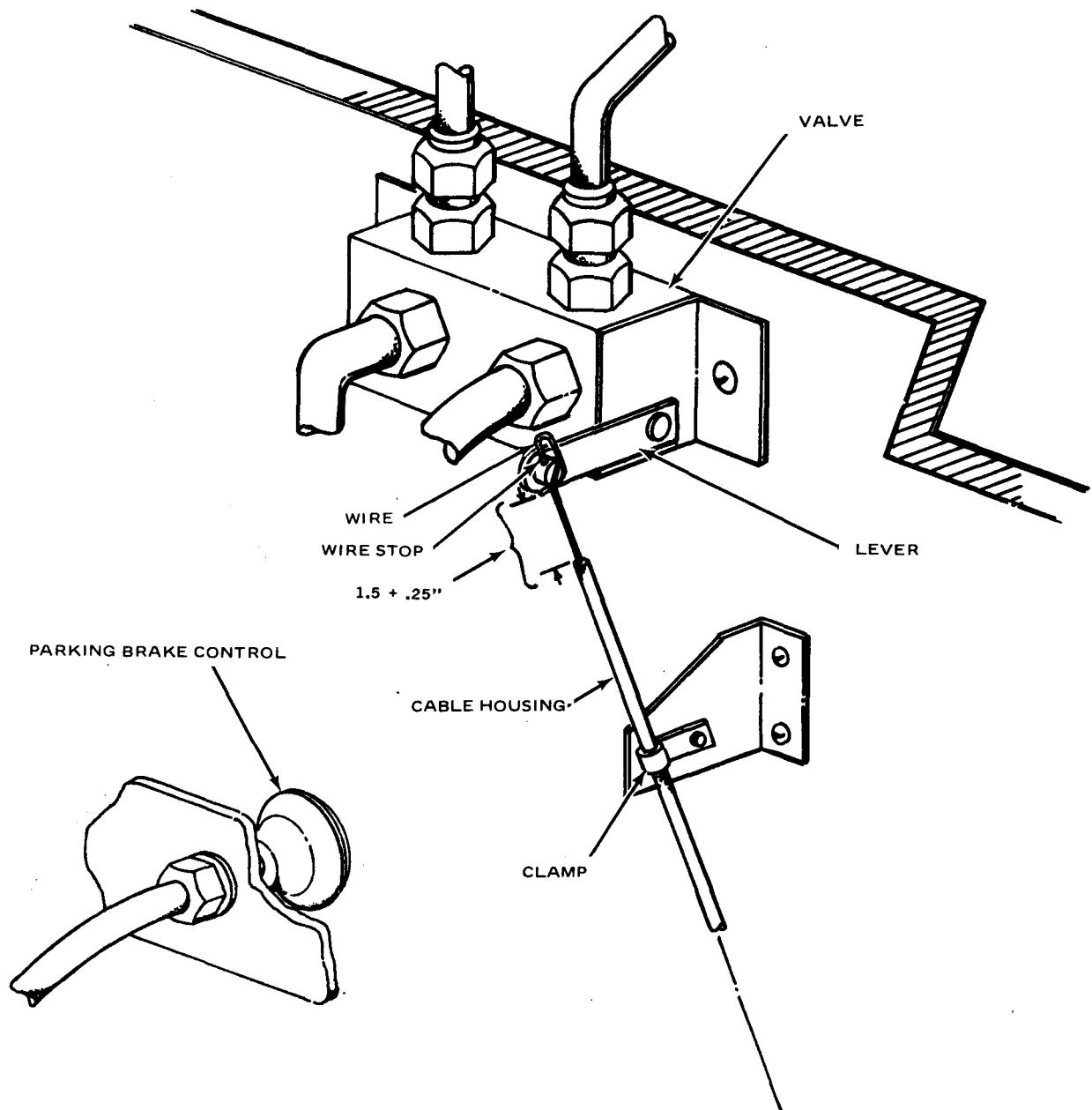

Parking Brake Rigging
(Dual Controls AA5A-0523 and Subsequent, AA5B-0693 and Subsequent)
Figure 205

AA-5 SERIES
MAINTENANCE MANUAL

CHAPTER 33

LIGHTING

TABLE OF CONTENTS

| <u>NUMBER</u> | | <u>PAGE</u> |
|---------------|---------------------------------------|-------------|
| 33-0 | LIGHTING | |
| | Description | 1 |
| | General | 1 |
| 33-1-1 | INTERIOR LIGHTS | |
| | Description/Operation | 1 |
| | Instrument Lights | 1 |
| | Dome and Map Lights | 3 |
| | Radio and Compass Dial Lights | 3 |
| | Maintenance Practices | 201 |
| | Replacements - Interior Lights | 201 |
| | Operational Check - Interior Lights | 202 |
| 33-4-1 | EXTERIOR LIGHTS | |
| | Description/Operation | 1 |
| | Landing Light (Optional) | 1 |
| | Navigation Lights | 1 |
| | Flashing Beacon (Optional) | 3 |
| | Strobe Lights (Optional) | 5 |
| | Troubleshooting (Strobe Light System) | 101 |
| | Maintenance Practices | 201 |
| | Replacement - Exterior Lights | 201 |
| | Slave Unit Removal/Installation | 202 |
| | Strobe Light Removal/Installation | 202 |
| | Flasher Assembly Removal/Installation | 203 |
| | Landing Light - Adjustment | 204 |
| | Exterior Lights - Operational Check | 205 |

**AA-5 SERIES
MAINTENANCE MANUAL**

LIGHTING - DESCRIPTION

1. General

To simplify this chapter, it has been divided into two sections. The first section will cover the interior lights, and the second section will cover the exterior lights.

The interior lights consist of instrument lights, dome lights and radio and compass lights. The exterior lights consist of landing light, navigation lighting, flashing beacon and strobe lights.

BULB CHART

| INTERIOR LIGHTS | | |
|------------------------|---|-----------------------------|
| Quantity | Type Light | Bulb Part No. |
| 5 | Instrument Lights | 1816 (G. E.) |
| 1 | Map Light - (FWD) AA5-0001 through 0021 | 1813 (G. E.) |
| 1 | Map Light - (FWD) AA5-0022 and Subsequent | 1816 (G. E.) |
| 1 | Dome Light-(AFT) | 1816 (G. E.) |
| 1 | Map Light (Optional) | G. E. -52 (G. E.) |
| 2 | Fuel Gauge Lights | 6037-001-704 (Drake) |
| N/A | Radio and Compass Lights | N/A |
| EXTERIOR LIGHTS | | |
| Quantity | Type Light | Bulb Part No. |
| 1 | Landing Light | 4509 (G.E. or Westinghouse) |
| 2 | Navigation Lights - (Wingtips) | 1512 (Grimes) |
| 1 | Navigation Light - (Tailcone) | 1777 (Grimes) |
| 1 | Flashing Beacon | 40-5A (Aero - Flash) |
| 2 | Strobe Lights - AA5-0001 through 0405 | X2RD (Aero - Flash) |
| 2 | Strobe Lights - AA5-0406 and Subsequent | X2RDA (Aero - Flash) |

INTERIOR LIGHTS - DESCRIPTION/OPERATION

1. Instrument Lights (See Figures 1 and 2)

The total instrument lighting system consists of three lights mounted in the glareshield, two fuel gauge lights and two lights mounted forward of the windshield bow. All seven lights are identical in components. The three lights mounted in the glareshield and two lights mounted forward of the windshield bow receive power through a dimming rheostat located on the instrument panel. The rheostat receives its power from the bus through a 10 amp fuse (Inst. & Nav. Lts.). Turning the control knob on the rheostat will vary the brightness of these lights.

The fuel gauge lights receive power through the same fuse, but this circuit is not through the rheostat. Therefore, the brightness of these lights is not controllable. These lights will come on when the master switch is placed in the ON position.

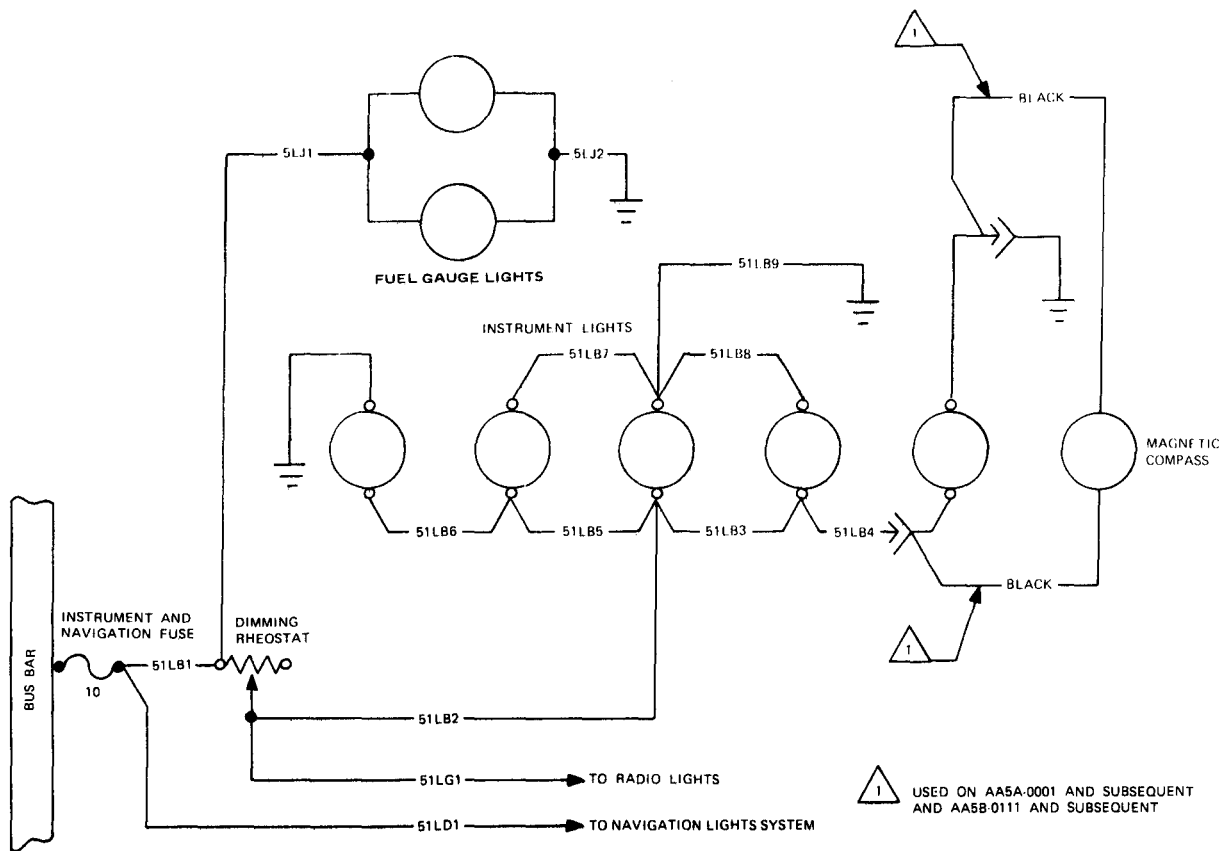

3480

Instrument Lights - Wiring Diagram
 Figure 1

AA-5 SERIES
MAINTENANCE MANUAL

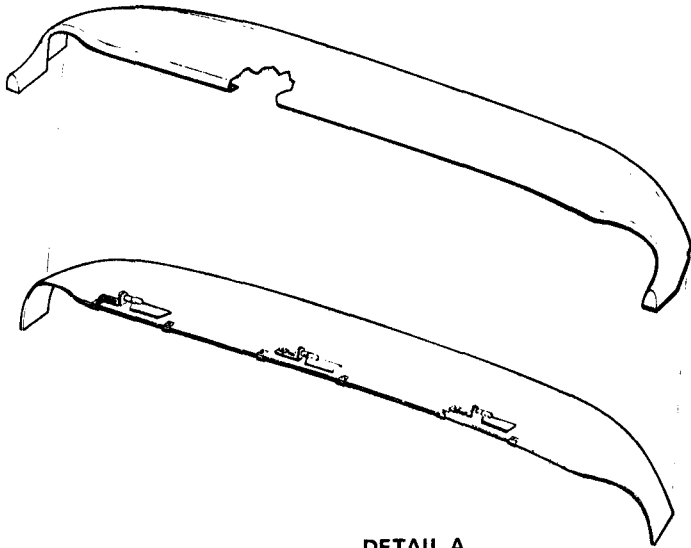
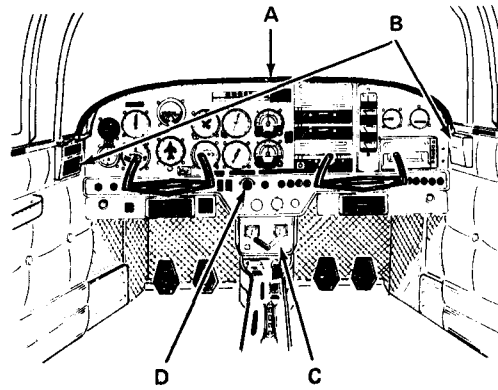

DETAIL A

3064

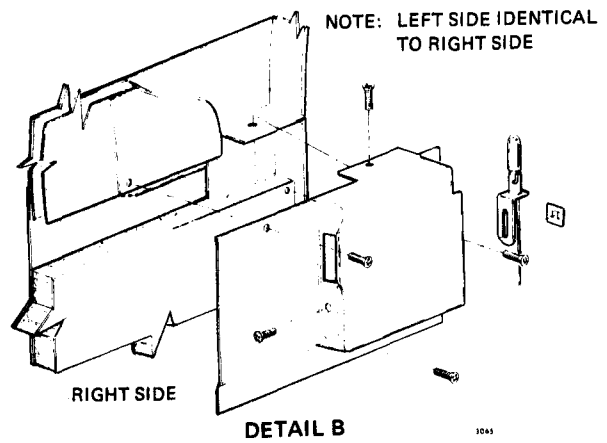

DETAIL B

3065

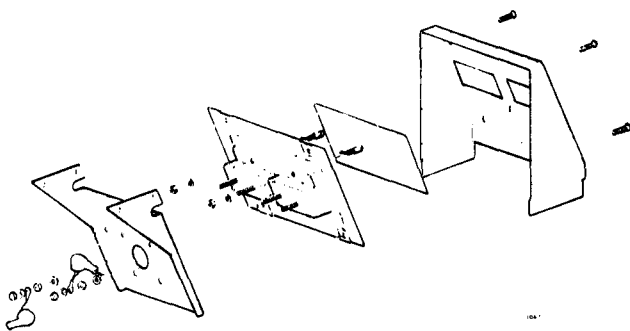

DETAIL C

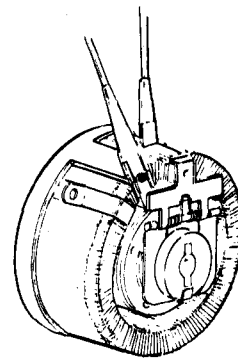

DETAIL D

3061

Instrument Lights
Figure 2

**AA-5 SERIES
MAINTENANCE MANUAL**

2. Dome and Map Lights (See Figure 3)

The dome (aft) light and map (forward) light are housed above and behind the pilot. They are controlled by a three-position rocker switch which is located on the fuselage side panel, to the left of the pilot's control wheel. The switch forward position activates the map (forward) light, neutral position is off and the aft position activates both the map (forward) light and the cabin dome (aft) light.

On AA5A-0001 and Subsequent and AA5B-0111 and Subsequent, an auxiliary map light mounted on a flex tube may be installed. This light will come on when the switch is placed in the forward position.

The three-position rocker switch receives power from the battery terminal of the battery contactor. A five amp fuse is in series with this circuit. On Aircraft AA5-0001 through 0405, the fuse is located in the main wire bundle forward of the firewall. On Aircraft AA5-0406 and Subsequent, AA5B-0001 and Subsequent and AA5A-0001 and Subsequent the fuse is located on a plate mounted to the battery support bracket. These lights are energized directly from the battery regardless of the master switch position.

3. Radio and Compass Dial Lights (See Figure 1)

The radio and compass dial lights are built into the individual units. The radio dial lights are controlled by the dimming rheostat located on the instrument panel. On AA5A-0001 and Subsequent and AA5B-0111 and Subsequent, the magnetic compass dial light is controlled by the dimming rheostat.

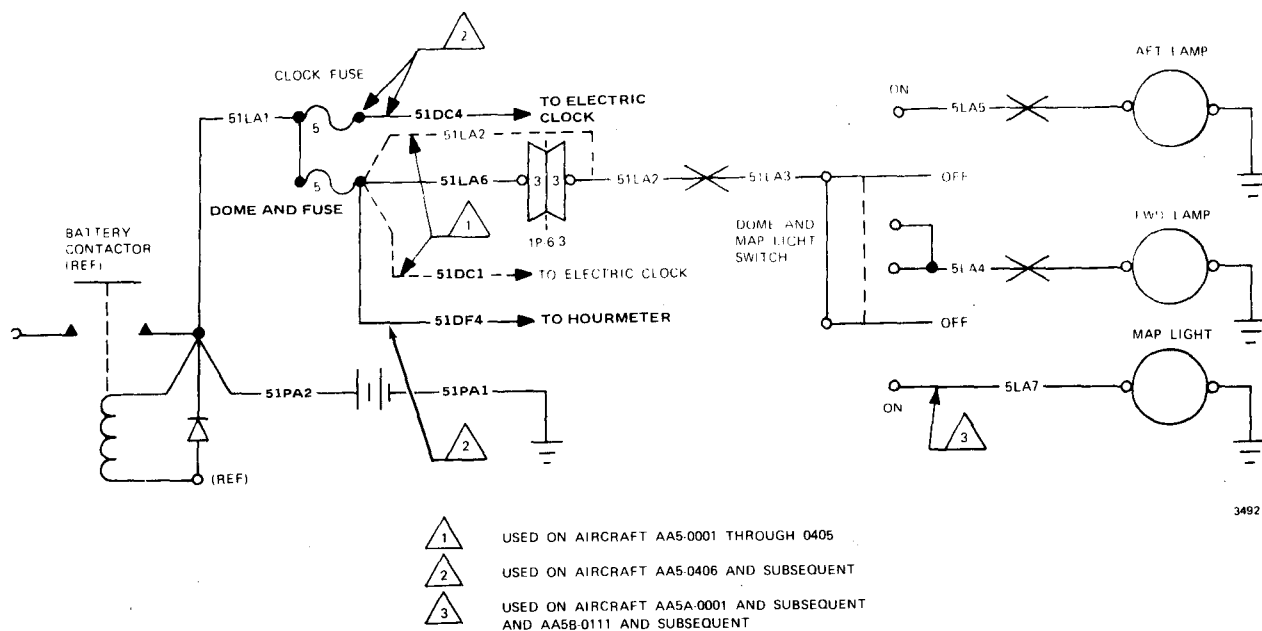

**Dome and Map Lights - Wiring Diagram
Figure 3**

INTERIOR LIGHTS - MAINTENANCE PRACTICES

1. Replacement of Instrument Lights (See Figure 2)

A. Glareshield Instrument Lights Replacement:

- (1) Removal of the screws from the glareshield lower lip will separate the two halves and expose the light assembly.
- (2) Remove the bulb and replace as required.
- (3) Replace lower lip and attaching hardware.

B. Replacement of Lights Mounted Forward of the Windshield Bow :

- (1) Remove the thermoplastic cover.
- (2) The light assembly is attached to the back of this cover. Remove the bulb and replace as required.
- (3) Replace the thermoplastic cover.

2. Replacement of Dome Lights

- A. Remove the screws which attach the thermoplastic dome light housing to the forward turtleback bulkhead.
- B. Remove the bulb and replace as required.

NOTE: On aircraft AA5-0001 through AA5-0405 the dome light is protected by an in-line fuse which is located in the main wire bundle forward of the firewall and near to the battery relay. On aircraft AA5-0406 and Subsequent, AA5B-0001 and Subsequent and AA5A-0001 and Subsequent, the dome light is protected by a fuse mounted on the battery box tray.

- C. Replace thermoplastic dome light housing and attaching hardware.

INTERIOR LIGHTS - OPERATIONAL CHECK

1. Instrument Lights

NOTE: Ensure fuses are operational before performing check.

- A. Place master switch to the ON position. Fuel gauge lights should illuminate
- B. Turn control knob on rheostat from dim to bright. While turning control knob, the three lights mounted on glareshield and two lights mounted/forward of the windshield bow should become brighter.
- C. Turn control knob on rheostat to OFF position. Lights should go out.
- D. Place master switch to OFF position. Fuel gauge lights should go out.

2. Dome and Map Lights

NOTE: Ensure fuses are operational before performing check.

- A. Place map and dome light switch to forward position. The forward (map) light located overhead should illuminate. On AA5A-0001 and Subsequent and AA5B-0111 and Subsequent, a map light mounted on a flex tube was made available. If installed, it should illuminate.
- B. Place map and dome light switch to the OFF (Center) position. The light (or lights if flex tube light is installed) should go out.
- C. Place map and dome light switch to the aft position. The aft and forward lights located overhead should illuminate.
- D. Place map and dome light switch to the OFF position. The lights should go out.

EXTERIOR LIGHTS - DESCRIPTION/OPERATION

1. Landing Light (Optional) (See Figures 1 and 2)

The landing light serves the dual purpose of landing light and taxi light. The light is located on the left lower corner of the forward engine cowl. On 1975 and later models, a clear plastic cover provides protection for the lamp.

The landing light is operated by a switch located to the left of the instrument lights rheostat on the instrument panel. The switch receives power from the bus through a ten amp fuse (Ldg Lt).

On pre 1975 models, adjustments to the landing light are made by opening the upper cowl and adjusting the mounting screws as required. On 1975 and later models, adjustments are made from the forward side of the cowl by removing the lamp shield.

2. Navigation Lights (See Figures 3 and 4)

The navigation lights consist of the two wing-tip lights, and the tail light mounted in the tailcone. The lights are controlled by a switch located on the lower instrument panel. Power for the lights is provided by the bus through a ten amp fuse (INST. & NAV. LTS.).

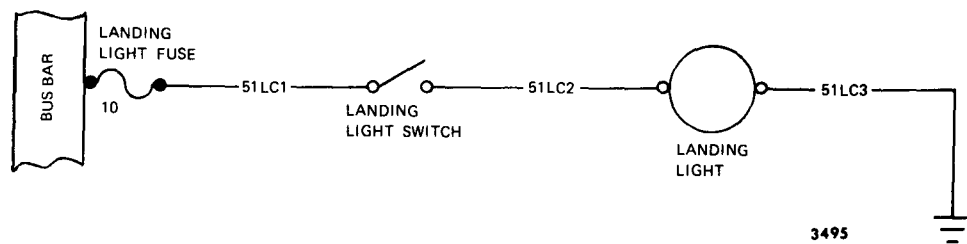

Landing Light - Wiring Diagram
Figure 1

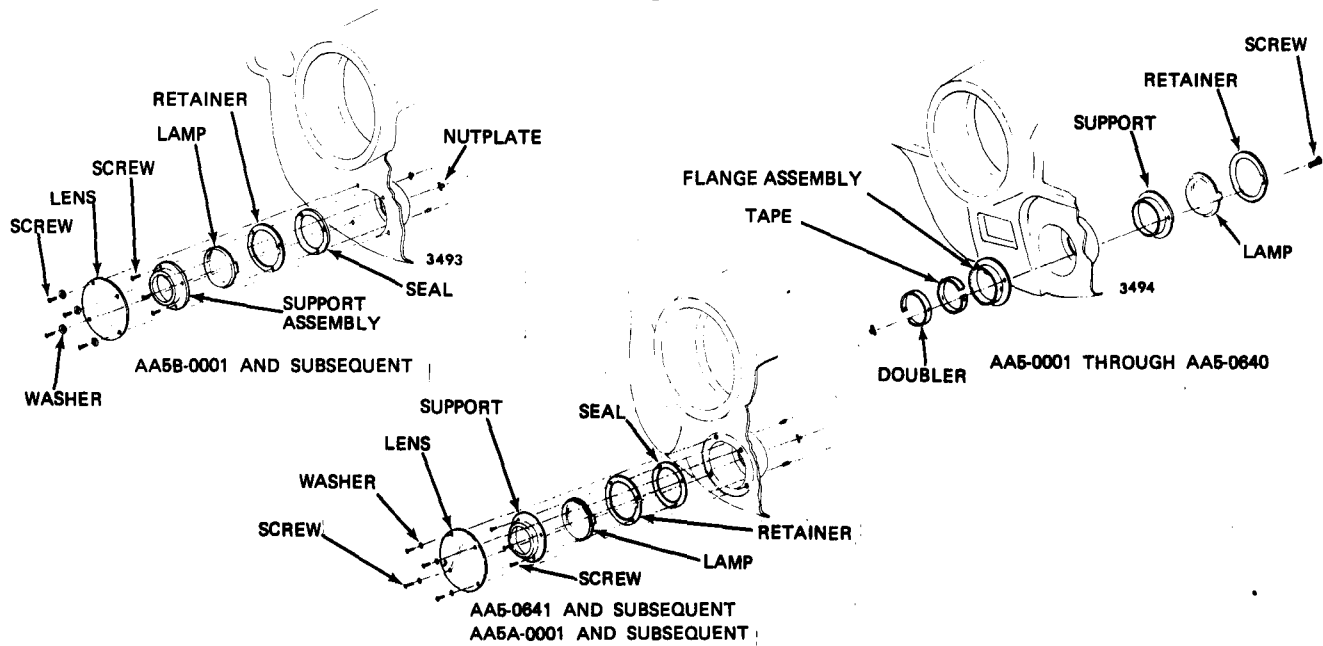

Landing Light
Figure 2

AA-5 SERIES
MAINTENANCE MANUAL

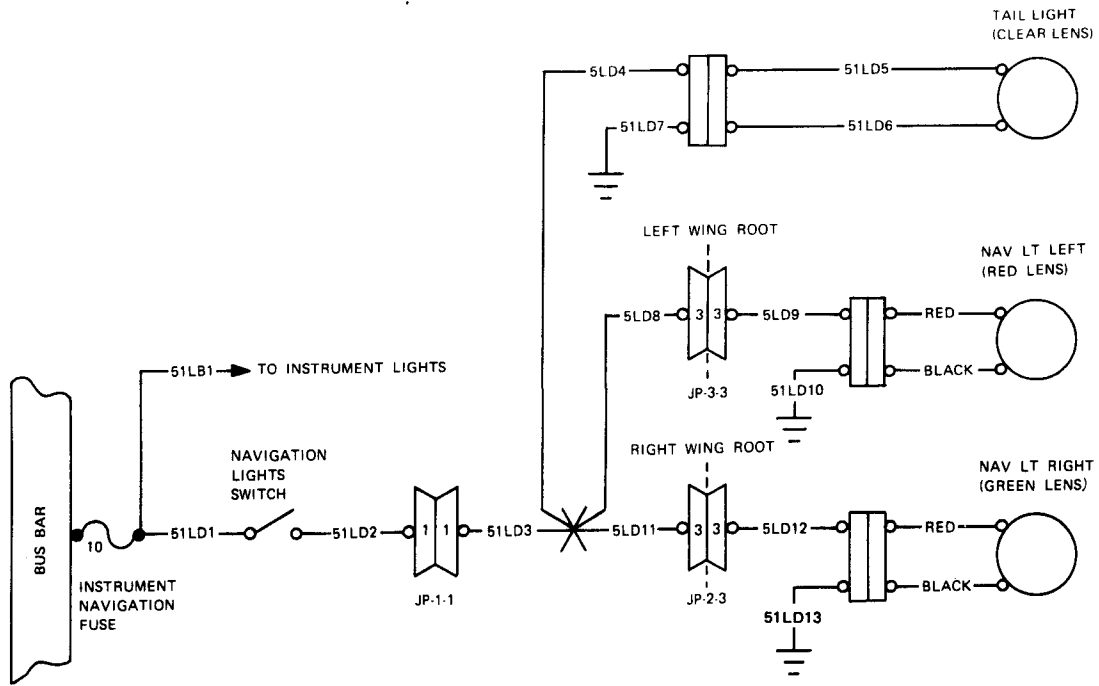

3497

Navigation Lights - Wiring Diagram
Figure 3

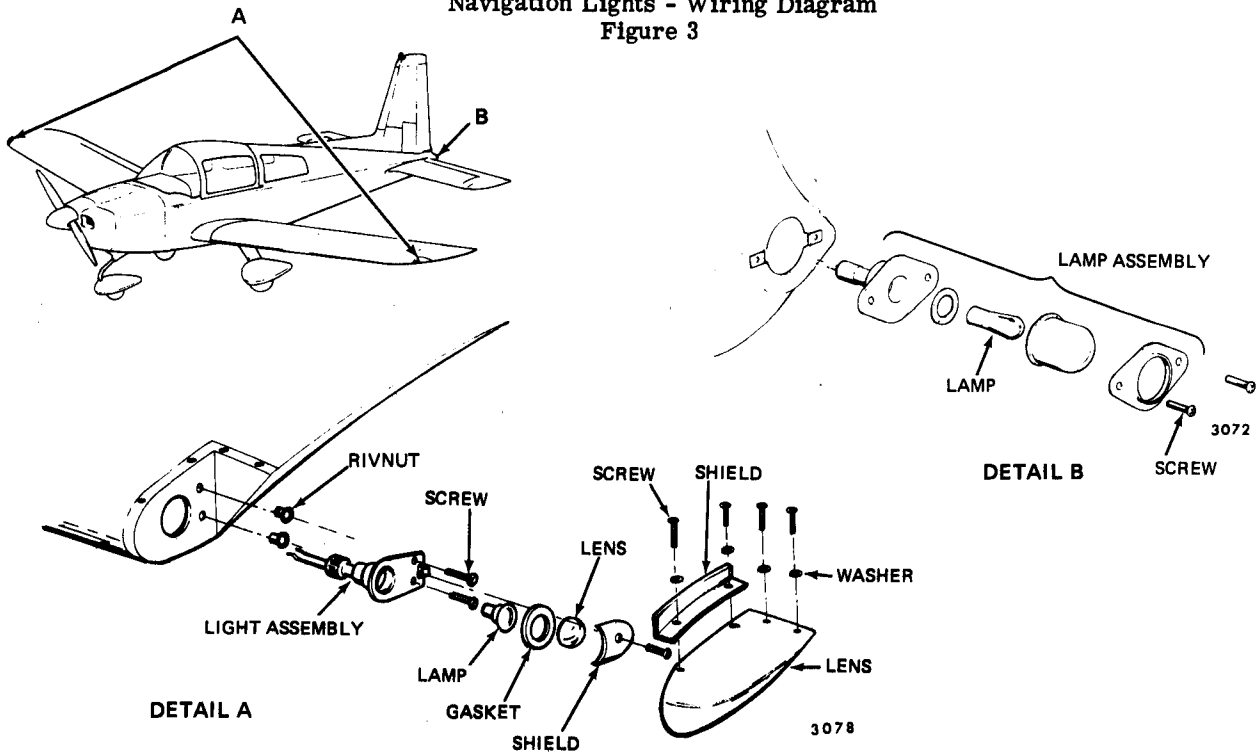

Navigation Lights
Figure 4

**AA-5 SERIES
MAINTENANCE MANUAL**

3. Flashing Beacon (Optional) (See Figure 5, 6 and 7)

The flashing beacon consists of the light assembly mounted on top of the vertical fin, and the slave unit (transistorized flasher unit) which is accessible through the right side tail inspection panel. The flashing beacon is an iodine vapor lamp electrically switched by the transistorized flasher unit.

The slave unit receives power from a switch located on the instrument panel. This switch receives power from the bus through a 15 amp fuse (Flash Bcn).

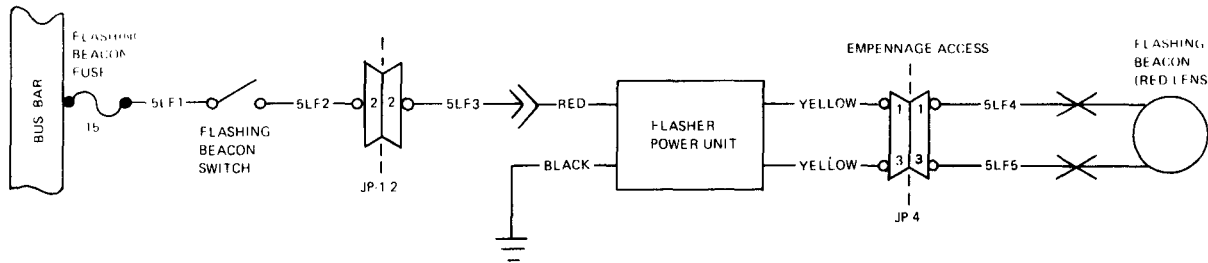

**Flashing Beacon - Wiring Diagram
(Aircraft AA5-0001 through AA5-0102)
Figure 5**

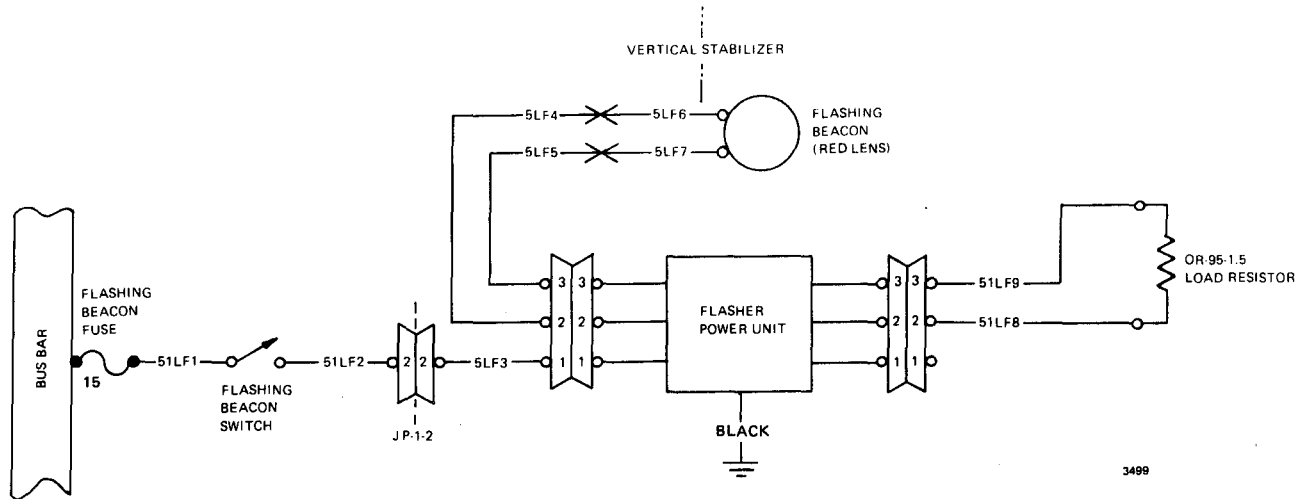

**Flashing Beacon - Wiring Diagram
(Aircraft AA5-0103 and Subsequent, AA5A-0001 and Subsequent and AA5B-0001 and Subsequent)
Figure 6**

AA-5 SERIES
MAINTENANCE MANUAL

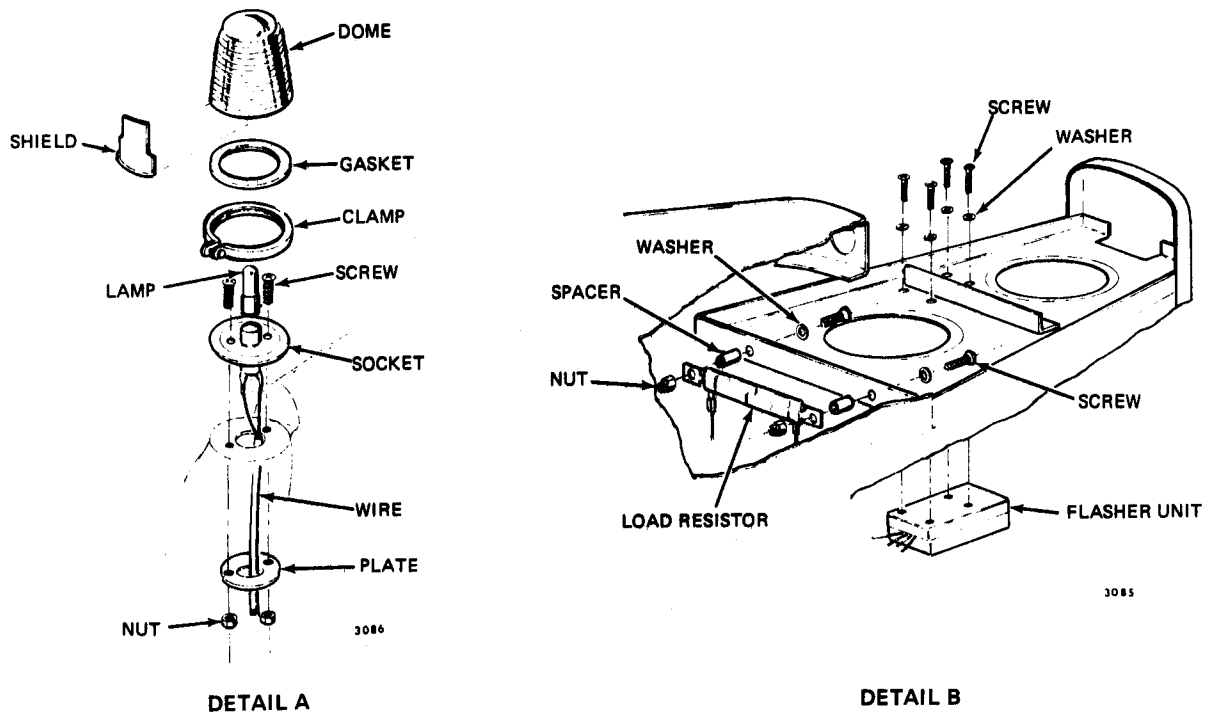
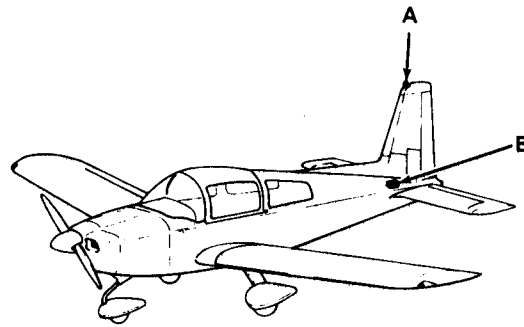

Flashing Beacon (Optional)
Figure 7

AA-5 SERIES
MAINTENANCE MANUAL

4. Strobe Lights (Optional) (See Figures 8 and 9)

The strobe light system consists of two flashers (power supplies) and two slaves (Strobe assemblies). The flasher is a solid state encapsulated electronic device. A flasher is mounted on each outer wing rib. The slave unit contains a lamp socket to hold the iodine quartz lamp and an outer covering glass dome. The slaves are mounted to the wing tip cutouts on the wing tips. They are located above and behind the navigation lights. Clear plastic lens are mounted over the lights to protect them from the weather.

On AA5-0001 through 0405, power for the flashers is provided by the bus through a 15 amp fuse (Flap & Strobe) located on the fuse panel.

On AA5-0406 through 0834 and AA5A/5B-0001 and Subsequent, power is provided by the bus through a 5 amp fuse (Fuel Pump & Strobe) located on the fuse panel.

Operation of the strobe lights is controlled by a rocker switch located on the instrument panel.

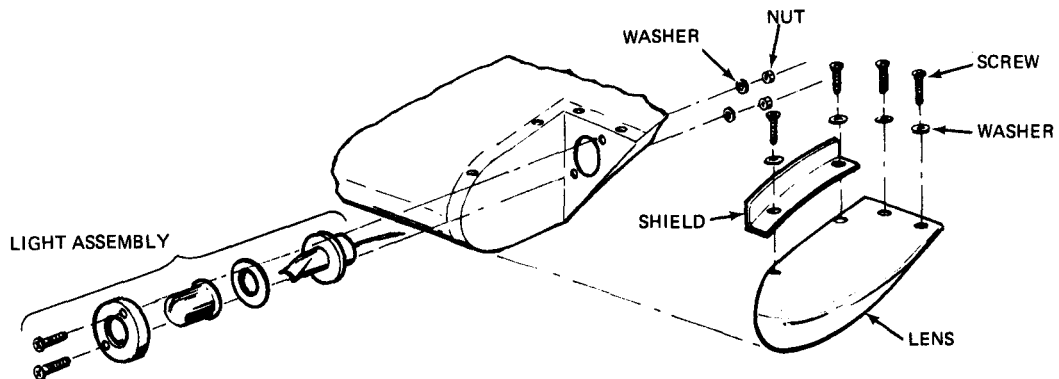

3080

Strobe Light
Figure 8

**AA-5 SERIES
MAINTENANCE MANUAL**

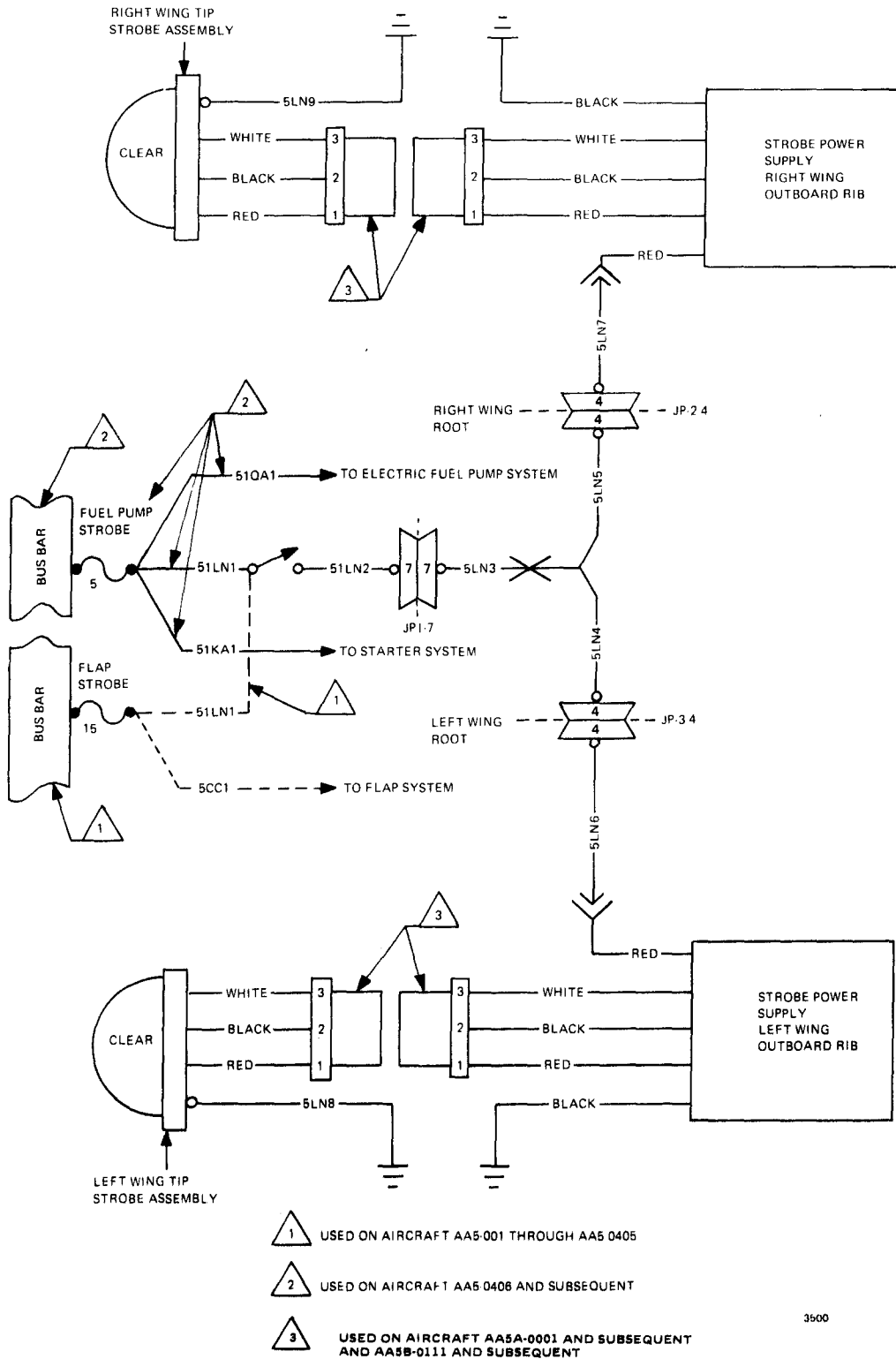

3500

**Wiring Diagram
Figure 9**

AA-5 SERIES
MAINTENANCE MANUAL

EXTERIOR LIGHTS - TROUBLESHOOTING

Strobe Light System

| TROUBLE | PROBABLE CAUSE | REMEDY |
|---------------------------------|---|--|
| Both flash tubes fail to flash. | Blown fuse | Check and replace if required. |
| | Defective switch | Check and replace if required. |
| | Defective wiring | Check wiring from bus to power supply (flasher power unit). |
| Only one side fails to flash. | Defective flash tube | Replace flash tube with known good flash tube (opposite wing). If operation is normal, replace defective flash tube. |
| | Shorted or open circuit to flash tube | Check wiring from power supply (flasher power unit) to the flash tube. |
| | Defective power supply unit because of reversed polarity of the input power | Replace power supply. |

EXTERIOR LIGHTS — MAINTENANCE PRACTICES

1. Exterior Lights Replacement

A. Replacement of Landing Light (See Figure 2.)

- (1) Gain access to the landing light by raising the upper cowl on pre 1975 models, or by removing the lamp shield on 1975 and later models.
- (2) Remove the three mounting screws and withdraw the lamp and bracket.
- (3) Disconnect the wires at the light terminals.
- (4) Remove light and replace as required.
- (5) Connect wires at the light terminal.
- (6) Place lamp in mounting bracket and replace hardware.
- (7) On pre-1975 models, close upper cowl. On 1975 and later models, replace lamp shield.
- (8) Perform operational check. (See Exterior Lights — Operational Check)

B. Replacement of Navigation Lights (Wing Tip) (See Figure 4.)

- (1) Remove the screws which attach the protective lens to the wing tip.
- (2) Remove the one screw which holds the lamp shield.
- (3) Remove the lamp and replace if necessary.
- (4) Replace lamp shield and securing screw.
- (5) Replace protective lens and attaching hardware to the wing tip.
- (6) Perform operational check. (See Exterior Lights — Operational Check)

C. Tail Light Replacement

- (1) Remove the two screws which hold the lamp retainer to the tailcone.
- (2) Withdraw the retainer and lens.
- (3) Remove the lamp and replace as required.
- (4) Replace lens and retainer to the tailcone.
- (5) Perform operational check. (See Exterior Lights — Operational Check)

D. Flashing Beacon Light Replacement (See Figure 7.)

- (1) Remove the clamp.
- (2) Withdraw the lens, shield, and lamp.

CAUTION: DO NOT HANDLE LAMP BY GLASS. INSERT INTO SOCKET BY BASE. ALWAYS WIPE LAMP OFF WITH TISSUE.

- (3) Remove and replace as required.
- (4) Replace lamp, shield, and lens.
- (5) Replace clamp.
- (6) Perform operational check. (See Exterior Lights — Operational Check)

2. Slave Unit Removal/Installation

A. Slave Unit Removal

- (1) Remove the left and right tail inspection cover. (ELT Inspection Covers)
- (2) Disconnect the wires.
- (3) Remove the four screws which attach the unit beneath the horizontal bulkhead and remove unit.

B. Slave Unit Installation

- (1) Place unit beneath the horizontal bulkhead and replace attaching hardware and ground wire.
- (2) Connect the remaining wires.
- (3) Replace the tail inspection covers.
- (4) Perform operational check. (See Exterior Lights — Operational Check)

3. Strobe Light Removal/Installation

A. Light Assembly Removal

WARNING: REMOVE POWER FOR 5 MINUTES BEFORE SERVICING SYSTEM.

- (1) Remove hardware attaching wing tip to the wing. (See Wing Tip Removal/Installation)
- (2) Disconnect wires going to navigation and strobe lights.
- (3) Remove wing tip.
- (4) Remove protective shield and supporting hardware from wing tip.
- (5) Remove hardware supporting light assembly to wing tip.
- (6) Remove light assembly.

B. Strobe Light Installation

- (1) Position light and install hardware supporting light assembly to wing tip.
- (2) Replace protective shield and hardware.
- (3) Connect wires going to navigation and strobe lights.
- (4) Replace wing tip and attaching hardware.
- (5) Perform operational check. (See Exterior Lights — Operational/Check.)

4. Flasher Assembly — Removal/Installation

A. Flasher Assembly — Removal

WARNING: REMOVE POWER FOR 5 MINUTES BEFORE SERVICING SYSTEM.

- (1) Remove hardware attaching wing tip to the wing. (See Wing Tip Removal/Installation.)
- (2) Disconnect wires going to navigation and strobe lights. Remove ground wire and attaching hardware.
- (3) Remove wing tip from wing.
- (4) Disconnect wires going to flasher unit.
- (5) Remove hardware supporting flasher unit to wing rib.
- (6) Remove flasher unit from wing rib.

B. Flasher Assembly — Installation

- (1) Replace flasher unit and supporting hardware.

CAUTION: THIS UNIT IS POLARITY SENSITIVE. THE WHITE OR RED LEAD IS POSITIVE AND THE BLACK LEAD AND/OR CASE IS NEGATIVE.

- (2) Connect wires going to flasher unit.
- (3) Connect wires going to navigation and strobe lights. Replace ground wire and attaching hardware.
- (4) Install wing tip and attaching hardware.
- (5) Perform Operational Check. (See Exterior Lights — Operational Check)

LANDING LIGHT — MAINTENANCE PRACTICES

NOTE: Before adjusting light, ensure tires are properly inflated.

1. Adjustment

A. Landing Light

- (1) Place aircraft on flat surface.
- (2) On pre 1975 models, open the upper cowl to gain access to the adjusting screws. On 1975 and later models, remove the lamp shield to gain access to the adjusting screws.
- (3) Adjust light in accordance with Figure 201.

NOTE: LANDING LIGHT SHOULD NOT BE ADJUSTED BEYOND THE POINT WHERE IT DOES NOT HAVE A GOOD SEAL AROUND OUTER FLANGE.

NOTE: LIGHT BEAM TO PARALLEL CENTER LINE.

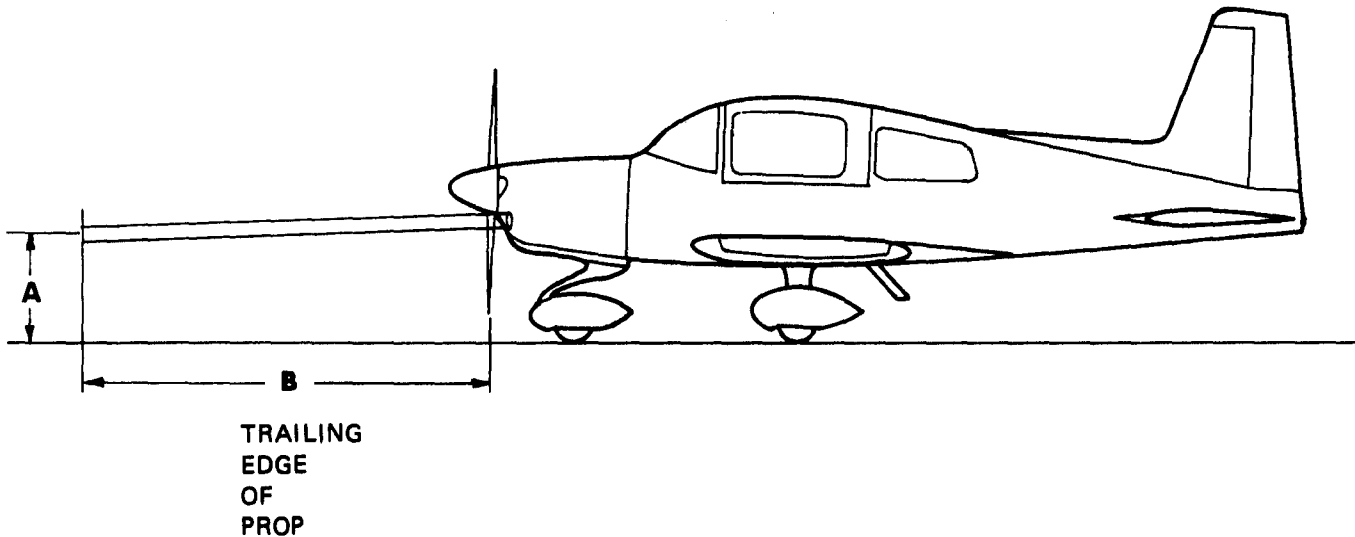

| | | |
|---|--------|--------|
| A | 29 in. | 26 in. |
| B | 6 Ft. | 10 Ft. |

Landing Light Adjustment
Figure 201

EXTERIOR LIGHTS — OPERATIONAL CHECK

1. Operational Check of Landing Light, Navigation Lights, Beacon Light, and Strobe Light

A. Landing Light (Optional)

NOTE: Ensure fuse is operational before performing check.

- (1) Place master switch to ON position.
- (2) Place landing light switch to ON position. Landing light should come on.
- (3) Place landing light switch to OFF position. Light should go out.
- (4) Place master switch to OFF position.

B. Navigation Lights

NOTE: Ensure fuse is operational before performing check.

- (1) Place master switch to ON position.
- (2) Place navigation light switch to ON position. The two lights mounted on each wing tip and the one light mounted on the tail cone should come on.
- (3) Place navigation light switch to OFF position. Navigation lights should go out.
- (4) Place master switch to OFF position.

C. Flashing Beacon (Optional)

NOTE: Ensure fuse is operational before performing check.

- (1) Place master switch to ON position.
- (2) Place flashing beacon switch to ON position. Flashing beacon should start flashing.
- (3) Place flashing beacon switch to OFF position. Lamp should stop flashing.
- (4) Place master switch to OFF position.

D. Strobe Lights (Optional)

NOTE: Ensure fuse is operational before performing check.

- (1) Place master switch to ON position.
- (2) Place strobe light switch to ON position. Strobe lights should come on.
- (3) Place strobe light switch to the OFF position. Strobe lights should go off.
- (4) Place master switch to OFF position.

CHAPTER 34

NAVIGATION

TABLE OF CONTENTS

| <u>NUMBER</u> | | <u>PAGE</u> |
|---------------|---|-------------|
| 34-0 | NAVIGATION SYSTEMS | |
| | Description/Operation | 1 |
| | General | 1 |
| 34-1-1 | PITOT AND STATIC PRESSURE SYSTEMS | |
| | Description/Operation | 1 |
| | General | 1 |
| | Troubleshooting | 101 |
| | Troubleshooting the Pitot and Static Pressure Systems | 101 |
| | Maintenance Practices | 201 |
| | Removal/Installation of Pitot and Static Pressure System Components | 201 |
| | Pitot and Static Pressure System Leakage Test | 201 |
| | Pitot Tube Alignment | 203 |
| 34-1-2 | AIR TEMPERATURE GAUGE | |
| | Description/Operation | 1 |
| | General | 1 |
| | Maintenance Practices | 201 |
| | Removal/Installation of Air Temperature Gauge | 201 |
| 34-1-3 | VERTICAL SPEED INDICATOR | |
| | Description/Operation | 1 |
| | General | 1 |
| | Troubleshooting | 101 |
| | Troubleshooting Vertical Speed Indicator | 101 |
| | Maintenance Practices | 201 |
| | Removal/Installation of Vertical Speed Indicator | 201 |

**AA-5 SERIES
MAINTENANCE MANUAL**

| <u>NUMBER</u> | | <u>PAGE</u> |
|---------------|--|-------------|
| 34-1-4 | AIRSPPEED INDICATOR | |
| | Description/Operation | 1 |
| | General | 1 |
| | Troubleshooting | 101 |
| | Troubleshooting Airspeed Indicator | 101 |
| | Maintenance Practices | 201 |
| | Removal/Installation of Airspeed Indicator | 201 |
| 34-1-5 | ALTIMETER | |
| | Description/Operation | 1 |
| | General | 1 |
| | Troubleshooting | 101 |
| | Troubleshooting the Altimeter | 101 |
| | Maintenance Practices | 201 |
| | Removal/Installation of Altimeter | 201 |
| 34-2-1 | DIRECTIONAL GYRO | |
| | Description/Operation | 201 |
| | General | 1 |
| | Troubleshooting | 101 |
| | Troubleshooting Directional Gyro | 101 |
| | Maintenance Practices | 201 |
| | Removal/Installation of Directional Gyro | 201 |
| 34-2-2 | ATTITUDE GYRO | |
| | Description/Operation | 1 |
| | General | 1 |
| | Troubleshooting | 101 |
| | Troubleshooting the Attitude Gyro | 101 |
| | Maintenance Practices | 201 |
| | Removal/Installation of Attitude Gyro | 201 |
| 34-2-3 | TURN AND BANK INDICATOR | |
| | Description/Operation | 1 |

**AA-5 SERIES
MAINTENANCE MANUAL**

| <u>NUMBER</u> | <u>PAGE</u> |
|--|-------------|
| General | 1 |
| Troubleshooting | 101 |
| Troubleshooting Turn and Bank Indicator | 101 |
| Maintenance Practices | 201 |
| Removal/Installation of Turn and Bank Indicator | 201 |
| 34-2-4 MAGNETIC COMPASS | |
| Description/Operation | 1 |
| General | 1 |
| Troubleshooting | 101 |
| Troubleshooting the Magnetic Compass | 101 |
| Maintenance Practices | 201 |
| Removal/Installation of Magnetic Compass | 201 |
| 34-5-1 TRANSPONDER | |
| Description/Operation | 1 |
| General | 1 |
| Maintenance Practices | 201 |
| Removal/Installation of Transponder | 201 |
| Removal/Installation of Transponder Antenna | 201 |
| 34-5-2 ADF SYSTEM | |
| Description/Operation | 1 |
| General | 1 |
| NARCO ADF 140/ADF 101 Automatic Direction Finder | 1 |
| KING KR 85/KI 225 Automatic Direction Finder | 2 |
| COLLINS ADF 650/IND-650 Automatic Direction Finder | 2 |
| Maintenance Practices | 201 |
| Removal/Installation of ADF Indicator | 201 |
| Removal/Installation of ADF Receiver | 201 |
| Removal/Installation of ADF Sensor (Loop) Antenna | 201 |

**AA-5 SERIES
MAINTENANCE MANUAL**

| <u>NUMBER</u> | <u>PAGE</u> |
|--|-------------|
| 34-5-3 DME SYSTEM | |
| Description/Operation | 1 |
| General | 1 |
| Maintenance Practices | 201 |
| Removal/Installation of DME Transmitter Receiver | 201 |
| 34-5-4 VOR SYSTEM | |
| Description/Operation | 1 |
| General | 1 |
| KING KX 170B/175B NAV/COM Transceiver | 2 |
| KING VOR/LOC-GS Indicators | 2 |
| NARCO NAV 14 Navigation Receiver and DGO 10 Display Unit | 3 |
| NARCO NAV 10-COM 10 System | 4 |
| NARCO NAV 11-NAV 12 Navigation System Unit | 5 |
| NARCO NAV 121-NAV 122 Navigation System | 7 |
| COLLINS Navigational System (1978 Model AA-5A and AA-5B) | 8 |
| Maintenance Practices | 201 |
| Removal/Installation of Navigation (VOR) System Units | 201 |
| Removal/Installation of NAV Antenna | 201 |

**AA-5 SERIES
MAINTENANCE MANUAL**

NAVIGATION SYSTEMS - DESCRIPTION/OPERATION

1. General

Not all AA-5, AA-5A, and AA-5B aircraft will have identical navigational equipment installed. As new systems with more effective applications become available, presently installed equipment may be replaced by these newer items. The basic items that provide minimum requirements to comply with FAA regulations are available on all aircraft. More diverse navigational items are installed as a customer option. It is the intent of this manual to present procedures and instructions adequate for minor inspection and flight line maintenance of all navigation equipment that may be installed on the aircraft including the optional items. Overhaul or shop maintenance of the navigation equipment must be performed in accordance with the individual manufacturers data.

**AA-5 SERIES
MAINTENANCE MANUAL**

PITOT AND STATIC PRESSURE SYSTEMS - DESCRIPTION/OPERATION

1. General

The pitot and static pressure systems supply impact (pitot) and atmospheric (static) pressure to various instruments. Some of these instruments require static pressure only; others require both static and pitot pressure for operation (see Figure 1). Both Systems operate independently of each other.

The pitot and static systems consists of metal and plastic tubing which convey ram air pressure and atmospheric pressure to the airspeed indicator, vertical speed indicator, and altimeter.

Ram air pressure is picked up by the pitot tube located under the left wing tip. From the pitot tube, a line runs along the trailing edge of the wing to the wing root and then to the instruments.

At the 100-hour inspection or when the airspeed indicator fails to operate properly the pitot line should be disconnected at the elbow or the plastic connection located inside the wing root in order to drain any moisture accumulation.

The static system, consisting of a static port on each side of the aft fuselage, conducts atmospheric pressure to the instruments. The line which runs from the ports to the instruments incorporates a moisture trap located behind the left rear seat upholstery side panel. It is recommended that the moisture trap drain be serviced at each static system test, or more often if fluctuations are observed in instruments connected to the static system, or if moisture is noted inside the cover glass of the airspeed indicator.

As an optional item the pitot tube is equipped with an electrical heating element for icing protection. The switch that controls the heating element is located on the instrument panel. Ref. Chapter 30 for complete details on pitot heat system. Also offered as an option is an alternate static air source. The control knob for the alternate static air source is located on the instrument panel.

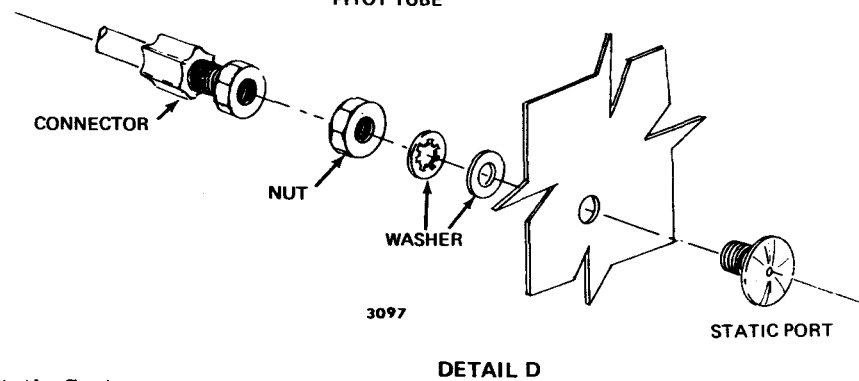
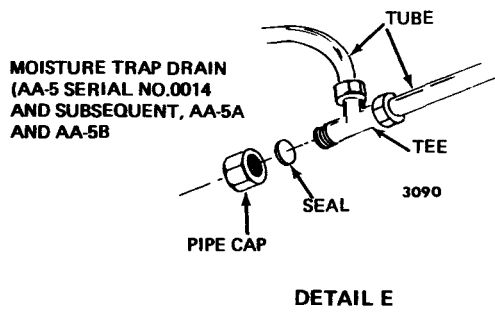
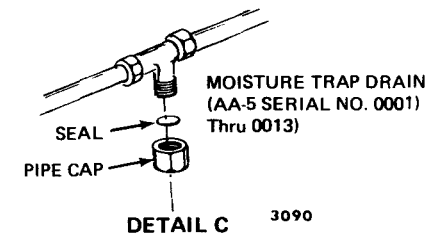
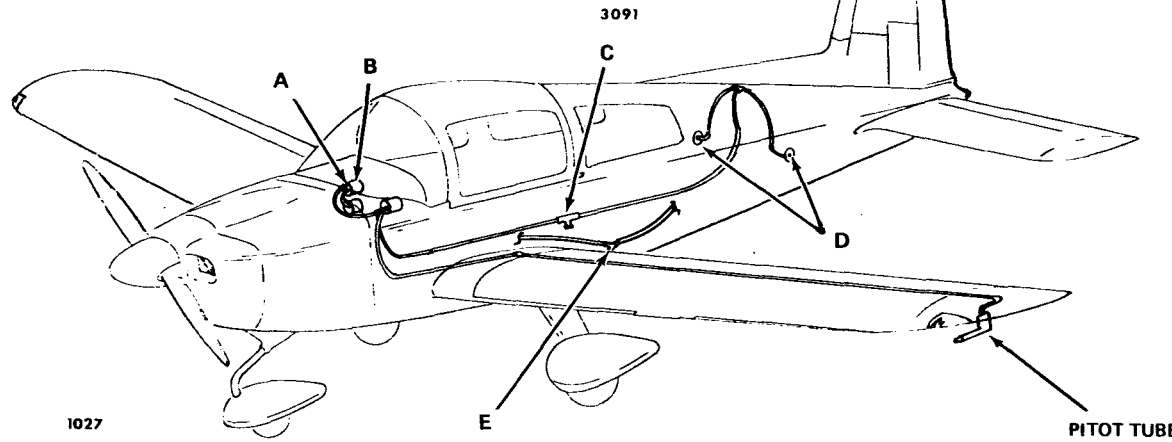
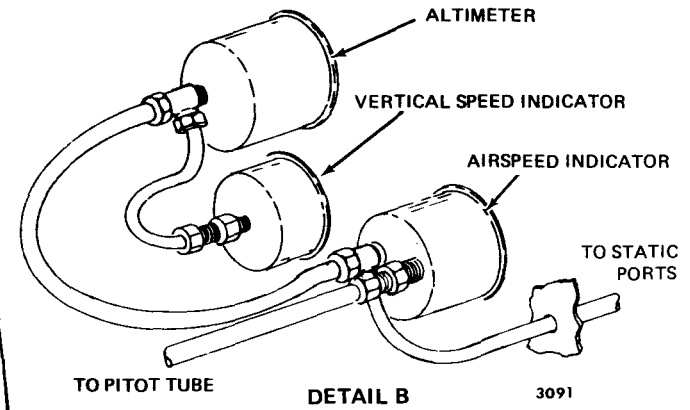
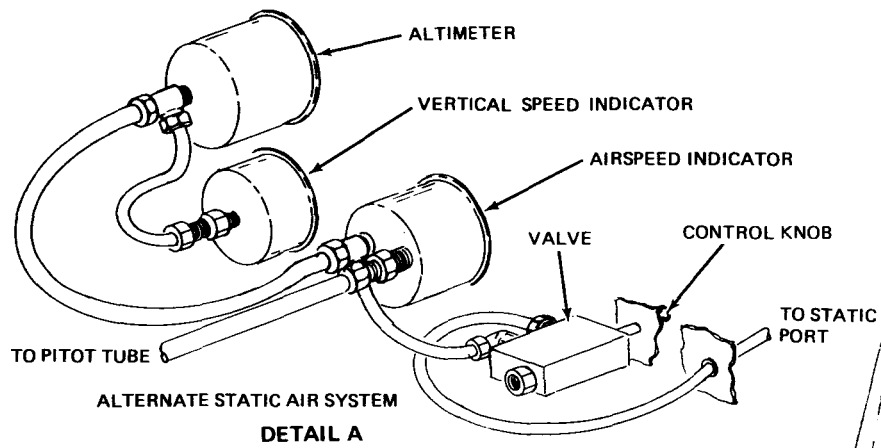

Pitot and Static System
Figure 1

PITOT AND STATIC PRESSURE SYSTEMS – TROUBLESHOOTING

1. Troubleshooting Pitot and Static Pressure Systems

| TROUBLE | PROBABLE CAUSE | REMEDY |
|--|---|--|
| Airspeed indicator fails to indicate. | Static bottoms blocked. Obstruction in pitot or static lines. | Check all lines and fittings for obstruction and clean as necessary. |
| | Water in static system. | Drain static system. |
| | Pitot line kinked or disconnected. | Check all pitot lines and repair as required. |
| Airspeed indicator fluctuates or indicates incorrectly. | Leak in pitot or static systems. | Tighten all connections system until no leakage is evident. |
| | Defective instrument. | Replace instrument. |
| | Instrument leakage. | Test instrument individually and replace if necessary. |
| Altimeter fails to operate. | Clogged static lines. | Check all lines and fittings and blow out as required. |
| | Defective instrument. | Replace instrument. |
| Altimeter fluctuates. | Instrument leakage | Test instruments individually and replace if necessary. |
| | Defective instrument. | Replace instrument. |
| | Leak in static system. | Tighten all connections and test system until no leakage is evident. |
| Vertical speed indicator fails to operate, fluctuates, or reads incorrectly. | Obstruction in static lines. | Remove, inspect and clean all static lines. |
| | Defective instrument. | Replace instrument. |
| | Instrument leakage. | Test instrument individually and replace if necessary. |

PITOT AND STATIC PRESSURE SYSTEMS - MAINTENANCE PRACTICES

1. Removal/Installation of Pitot and Static Pressure System Components

A. Remove Pitot Tube (Figure 201)

- (1) Remove left wing tip to gain access to pitot tube attaching hardware.
- (2) Disconnect pitot tube air inlet line and wiring.
- (3) Remove hardware supporting pitot tube mount to wing spar and wing rib.
- (4) Remove pitot tube assembly.

B. Install Pitot Tube Assembly

- (1) Place pitot tube assembly in position and install attaching hardware.
- (2) Connect pitot tube air inlet line and wiring.
- (3) Replace wing tip.

2. Pitot and Static Pressure System Leakage Test

A. Test the Pitot System

CAUTION: NEVER APPLY SUCTION TO THE PITOT TUBE UNLESS THE AIRSPEED INDICATOR IS DISCONNECTED.

- (1) Insert a surgical type rubber hose, approximately 24 inches long over the pitot tube.

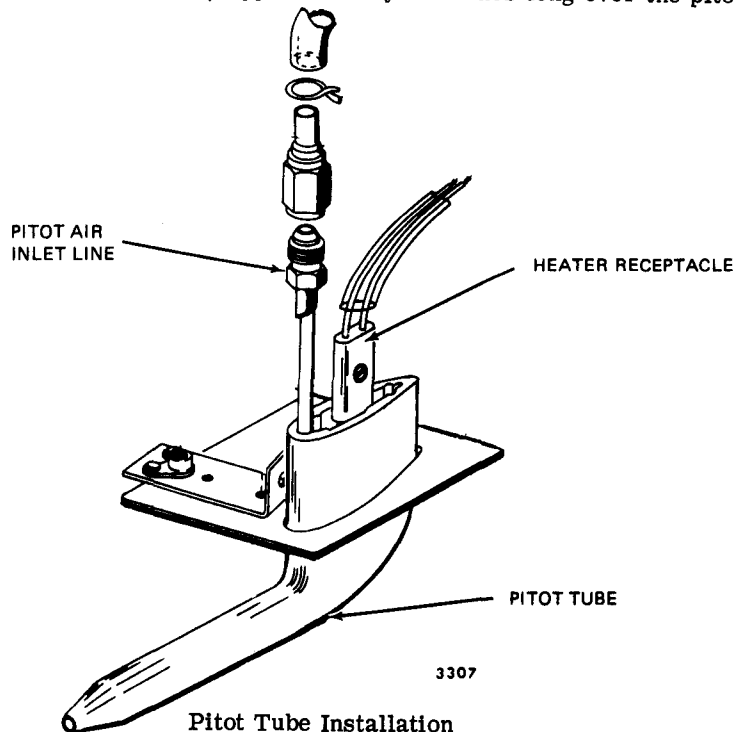

Pitot Tube Installation
Figure 201

**AA-5 SERIES
MAINTENANCE MANUAL**

- (2) Apply pressure by closing the opposite end of the tube and slowly roll up rubber hose until the airspeed indicator registers between 120-150 mph.
- (3) Secure the rolled-up end of the hose to prevent it from unrolling.
- (4) After two or three minutes, recheck the airspeed indicator. Any leakage in the system will result in a lower airspeed indication. If the reading has decreased more than 1 mph per minute, an undesirable leak exists somewhere in the system.

NOTE: Be sure the test hose is not losing pressure.

- (5) To eliminate the leak, check all connections and tighten all fittings in the system as necessary and apply thread sealant sparingly as required. Inspect the pitot line in the wing root and replace the hose if it appears deteriorated.
- (6) Repeat steps (1) through (4)

B. Test the Static System

CAUTION: NEVER APPLY POSITIVE PRESSURE TO THE STATIC SYSTEM UNLESS ALL INSTRUMENTS ARE DISCONNECTED.

FAR 91.170 requires that static systems and altimeters be checked every 24 months for IFR. The most common method of testing static systems is covered in FAR 43, Appendix E, "Altimeter System Test and Inspection". Additional information may be found in FAA Advisory Circular No. AC 43-203 A. An approved alternate method specifically for the AA-5, AA-5A and AA-5B is listed below. Perform testing as follows:

- (1) Ensure that altimeter has been tested and approved by an appropriately rated repair facility per FAR Part 43, Appendix E, prior to aircraft system test.
- (2) Seal off one static port opening with plastic tape. This must provide an air tight seal.
- (3) Attach a source of suction to the remaining static port. If an alternate static source is installed, assure that control is in OFF position.

NOTE: One method of applying suction is to insert a hypodermic syringe into the static port and slowly withdraw the plunger of the syringe. Ensure the syringe does not leak and an airtight seal is maintained during test.

- (4) Slowly apply suction until the altimeter indicates a 1000-foot increase in altitude.
- (5) Secure the suction source to maintain a closed system. Leakage shall not exceed a decrease of 100 feet of altitude per minute, as indicated on the altimeter.
- (6) If the leakage rate exceeds 100 feet per minute, check and retighten all connections and fittings.
- (7) Repeat steps (1) through (6).
- (8) If the leakage rate is still too high, disconnect the static lines from the individual instruments.
- (9) Proceeding one at a time, and using suitable fittings, connect the lines together so that the altimeter is the only instrument still connected to the static pressure system.
- (10) Repeat the leakage test to determine whether the static pressure system or the instruments disconnected from the system are the cause of leakage. If the instruments are at fault, they must be repaired by an appropriately rated repair station or replaced. If the static pressure system is at fault, repeat the procedure given in step (6).

3. Pitot Tube Alignment.

Figure 202 shows an outline of the wing contour and a series of parallel lines. To check the proper alignment of the pitot tube, make a template conforming to the lines shown in Figure 202. If the pitot tube is properly aligned, it should parallel one of the lines.

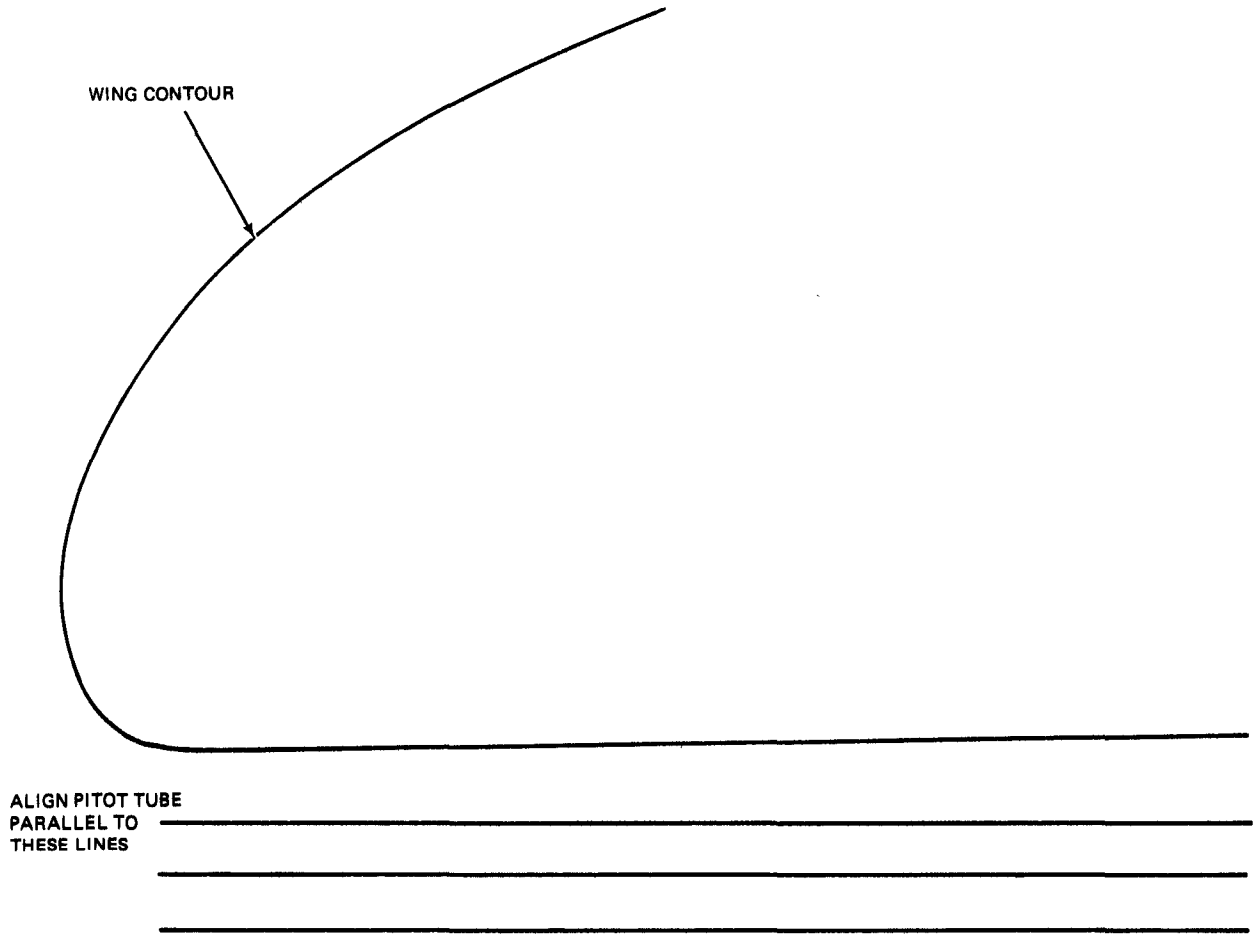

Pitot Tube Alignment Template
Figure 202

**AA-5 SERIES
MAINTENANCE MANUAL**

AIR TEMPERATURE GAUGE - DESCRIPTION/OPERATION

1. **General**

The outside air temperature gauge is located on the upper center of the windshield. The gauge is a mechanically operated instrument actuated by expansion of a metallic element to give the temperature indication on the face of the instrument. The range of temperature readings are from 144° F (64° C) to -64° F (-54° C).

AIR TEMPERATURE GAUGE – MAINTENANCE PRACTICES

1. Removal/Installation of Air Temperature Gauge

A. Remove Air Temperature Gauge (Figure 201)

- (1) Hold the gauge on the inside of the windshield and unscrew and remove hexagonal gauge cover.
- (2) Remove washers and tube adapter from outside of windshield.
- (3) Remove gauge, tube adapter, and washers from inside of windshield.

B. Install Air Temperature Gauge

- (1) Assemble tube adapter and washers on gauge stem (Figure 201).
- (2) Apply one or two drops of Loctite sealant, grade EV to the gauge stem threads.
- (3) Insert gauge stem through mounting hole from inside the windshield.
- (4) Assemble tube adapter and washers on gauge stem on outside of windshield (See Figure 201).
- (5) Apply a small bead of Presstite soft putty around gauge stem between rubber washer and metal washer on outside of windshield.

CAUTION: DO NOT OVERTIGHTEN OR STEM THREADS WILL SEPARATE FROM GAUGE CASE.

- (6) Install sun screen on gauge stem and tighten snug tight using hands only.

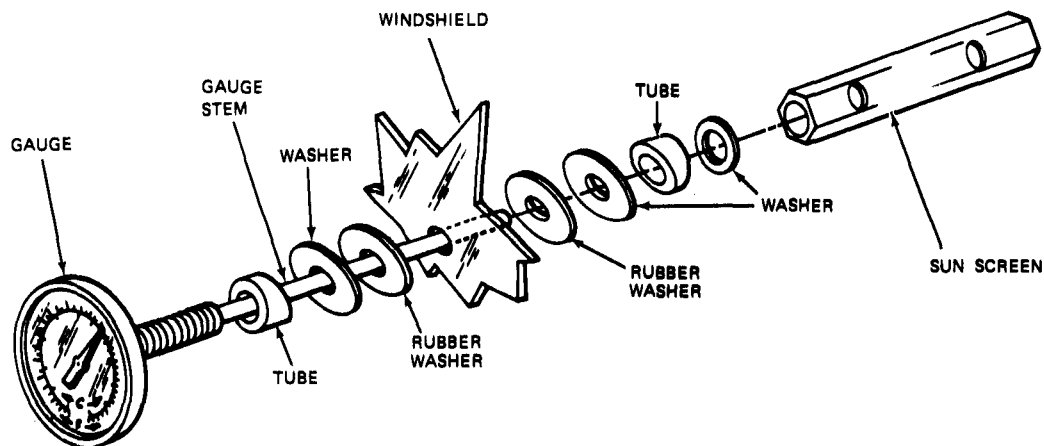

Air Temperature Gauge Installation
Figure 201

VERTICAL SPEED INDICATOR - DESCRIPTION/OPERATION

1. General

The vertical speed indicator (Figure 1), located on the instrument panel, measures the rate of change in static pressure when the aircraft is climbing or descending. By means of a pointer and dial this instrument will indicate the rate of ascent or descent of the aircraft in feet per minute. But due to the lag of the instrument, the aircraft will be climbing or descending before the instrument starts to read and the instrument will continue to read after the aircraft has assumed level flight. In rough air the lag of the instrument should not be considered a malfunction.

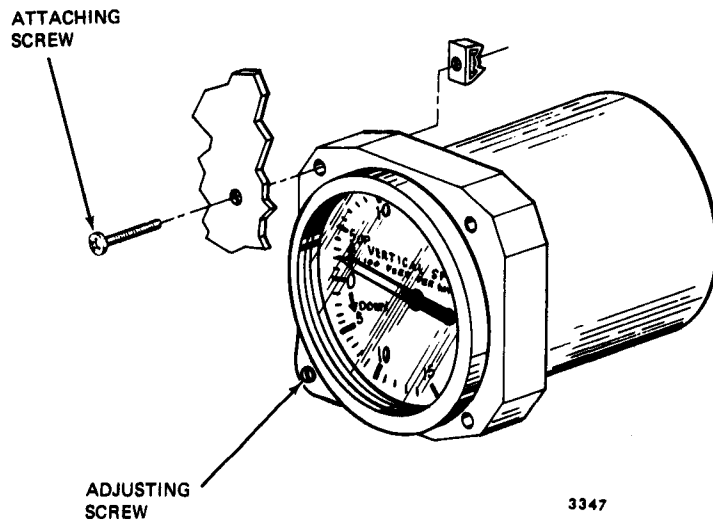

Vertical Speed Indicator
Figure 1

VERTICAL SPEED INDICATOR — TROUBLESHOOTING

1. Troubleshooting Vertical Speed Indicator

| TROUBLE | PROBABLE CAUSE | REMEDY |
|--|--------------------------------------|--|
| Pointer fails to respond. | Obstruction in static line. | Disconnect all instruments connected to the static line. Clear line. Remove cap at low place in static line and drain line. |
| Pointer oscillates. | Leaks in static lines. | Disconnect all instruments connected to the static line. Check individual instruments for leaks. Reconnect instruments to static line and test installation for leaks. |
| | Defective mechanism. | Replace instrument. |
| Rate of climb indicates when aircraft is banked. | Water in static line. | Remove cap at low place in static line and drain line. |
| Pointer has to be set before every flight. | Temperature compensator inoperative. | Replace instrument. |
| Pointer cannot be reset to zero. | Diaphragm distorted. | Replace instrument. |
| Instrument reads very low during climb or descent. | Instrument case broken or leaking. | Replace instrument. |

VERTICAL SPEED INDICATOR - MAINTENANCE PRACTICES

1. Removal/Installation of Vertical Speed Indicator

A. Remove Vertical Speed Indicator.

- (1) Remove screws securing deck assembly to instrument panel.
- (2) Raise deck assembly and tape to windshield.
- (3) Locate vertical speed indicator on instrument panel and loosen fitting to disconnect tubing from rear of indicator.
- (4) Remove three screws and nuts mounting vertical speed indicator to instrument panel and remove indicator.

B. Install Vertical Speed Indicator

- (1) Position vertical speed indicator in place on instrument panel and install three screws and nuts securing vertical speed indicator to instrument panel.
- (2) Connect tubing to back of indicator. Secure by tightening fitting.
- (3) Position deck assembly in place and install screws securing deck assembly to instrument panel.

AIRSPPEED INDICATOR - DESCRIPTION/OPERATION

1. General

The airspeed indicator (Figure 1) located on the instrument panel provides a means of indicating the speed of the aircraft passing through the air. The airspeed indication is derived from the differential pressure between pitot air pressure and static air pressure. This instrument has its diaphragm vented to the pitot air source and its case vented to the static air system. As the aircraft increases speed, the pitot air pressure increases, causing the diaphragm to expand. A mechanical linkage picks up this motion and moves the instrument pointer to the indicated speed. The instrument dial is calibrated in knots and miles per hour, and also has the necessary operating range markings for safe operation of the aircraft.

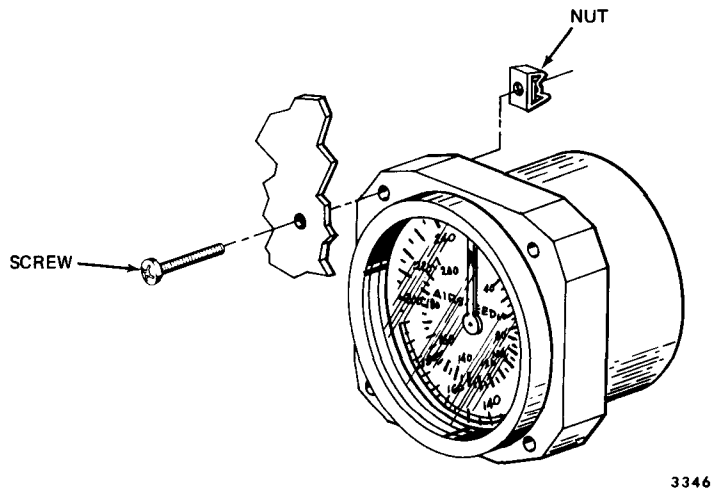

Airspeed Indicator
Figure 1

AIRSPPEED INDICATOR – TROUBLESHOOTING

1. Troubleshooting Airspeed Indicator

| TROUBLE | PROBABLE CAUSE | REMEDY |
|---|--|---|
| Pointer of airspeed indicator does not indicate properly. | Leak in instrument case or in pitot lines. | Check for leak and seal. |
| Pointer of airspeed indicator oscillates. | Defective mechanism. | Replace instrument. |
| Instrument reads high. | Pointer not on zero. | Replace instrument. |
| | Leaking static system. | Find leak and correct. |
| Instrument reads low. | Pointer not on zero. | Replace instrument. |
| | Leaking static system. | Find leak and correct. |
| | Pitot tube not aligned correctly. | Realign pitot tube. See Section 34-1-1. |
| Airspeed changes as aircraft is banked. | Water in pitot line. | Remove static line from altimeter and blow out pitot line from cockpit to pitot tube. |

AIRSPPEED INDICATOR - MAINTENANCE PRACTICES

1. Removal/Installation of Airspeed Indicator

A. Remove Airspeed Indicator

- (1) Remove screws securing deck assembly to instrument panel.
- (2) Raise deck assembly and tape to windshield.
- (3) Locate airspeed indicator on instrument panel and loosen fittings to disconnect tubing from the connections on back of indicator.
- (4) Remove four mounting screws securing airspeed indicator to instrument panel and remove indicator.

B. Install Airspeed Indicator

- (1) Position airspeed indicator in place on instrument panel and install four screws securing airspeed indicator to instrument panel.
- (2) Connect tubing to connections on back of indicator.
- (3) Place deck assembly in position and install screws securing deck assembly to instrument panel.

ALTIMETER - DESCRIPTION/OPERATION

1. General

The altimeter (Figure 1), located on the instrument panel indicates pressure altitude in feet above sea level. The indicator has three pointers and a dial scale; the long pointer is read in hundreds of feet, the middle pointer in thousands of feet and the short pointer in ten thousands of feet. A barometric pressure window is located on the right side of the indicator dial. The barometric pressure indication is set by the knob located on the lower left corner of the instrument. The altimeter consists of a sealed diaphragm that is connected to the pointers through a mechanical linkage. The instrument case is vented to the static air system, and as static air pressure changes the diaphragm changes causing the pointers to move through the mechanical linkage.

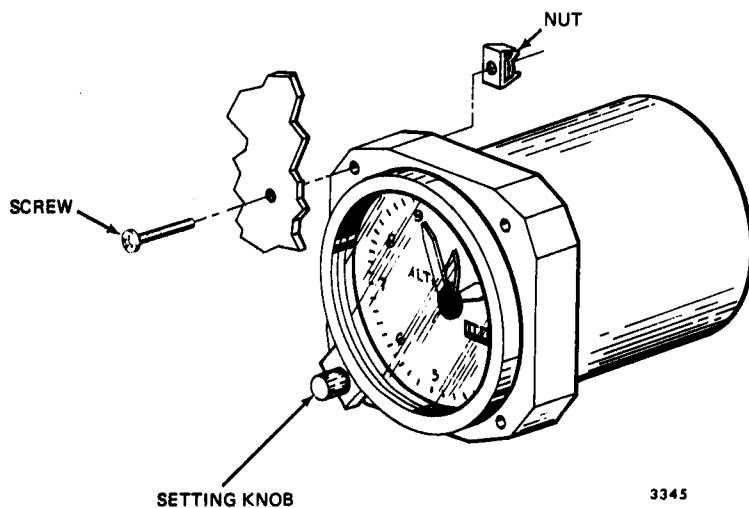

Altimeter
Figure 1

ALTIMETER – TROUBLESHOOTING

1. Troubleshooting the Altimeter

| TROUBLE | PROBABLE CAUSE | REMEDY |
|--|---|---|
| Excessive scale error. | Improper calibration adjustment. | Replace instrument. |
| Excessive pointer oscillation. | Defective mechanism. | Replace instrument. |
| High or low reading. | Improper venting. | Eliminate leak in static pressure system. |
| Setting knob is hard to turn. | Wrong lubrication or lack of lubrication. | Replace Instrument. |
| Inner reference marker fails to move when setting knob is rotated. | Out of engagement. | Replace instrument. |
| Setting knob setscrew loose or missing. | Not tight when altimeter was reset. | Tighten instrument screw, if loose. Replace instrument, if screw is missing. |
| Cracked or loose cover glass. | Case gasket hardened. | Replace instrument. |
| Dull or discolored markings. | Age. | Replace markings. |
| Barometric scale and reference markers out of synchronism. | Slippage of mating parts. | Replace instrument. |
| Barometric scale and reference markers out of synchronism with pointers. | Drive in mechanism. | Reset pointers, per AC43.13-1 Chapter 7 dated June 12, 1969. |
| Altimeter sticks at altitude or does not change with change of altitude. | Water or restriction in static line. | Remove static lines from all instruments, and blow line clear from cockpit to static ports. |
| Altimeter changes reading as aircraft is banked. | Water in static line. | Remove drain cap from static line and drain water from line. |
| Altimeter requires resetting frequently. | Temperature compensator inoperative. | Replace instrument. |

ALTIMETER - MAINTENANCE PRACTICES

1. Removal/Installation of Altimeter

A. Remove Altimeter

- (1) Remove screws securing deck assembly to instrument panel.
- (2) Raise deck assembly and tape to windshield.
- (3) Locate altimeter on instrument panel and loosen fittings to disconnect tubing from tee connection on back of instrument.
- (4) Remove three screws securing altimeter to instrument panel and remove altimeter.

B. Install Altimeter

- (1) Position altimeter in place on instrument panel and install three mounting screws securing altimeter to instrument panel.
- (2) Connect tubing to tee connection on back of altimeter.
- (3) Place deck assembly in position and install screws securing deck assembly to instrument panel.

DIRECTIONAL GYRO - DESCRIPTION/OPERATION

1. General

The directional gyro (Figure 1) located on the instrument panel is a flight instrument incorporating an air driven gyro stabilized in the vertical plane. This instrument operates off the vacuum system (See Chapter 37). The gyro is rotated at high speed by lowering the pressure in the airtight case and simultaneously allowing atmospheric air pressure to enter the instrument against the gyro buckets. Due to gyroscopic inertia, the spin axis continues to point in the same direction even though the aircraft yaws to the right or left. This relative motion between the gyro and the instrument case is shown on the instrument dial which is similar to a compass card. The dial, when set to agree with the aircraft magnetic compass, provides a positive indication free from swing and turning error. The gyro should only be checked to the heading on which it was first set. Due to internal friction, spin axis error, air turbulence and airflow, the gyro should be set at least every 15 minutes for accurate operation.

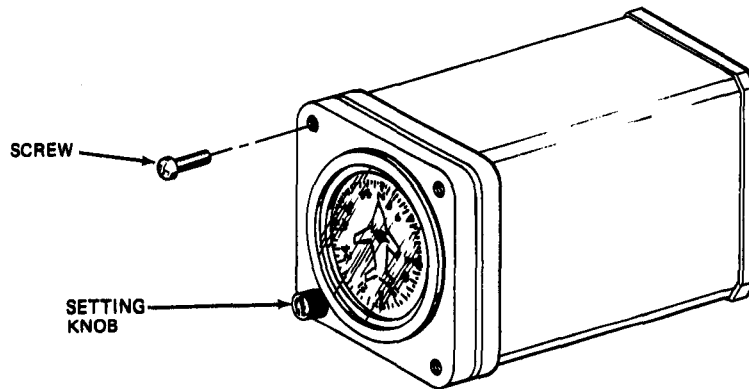

3344

Directional Gyro
Figure 1

DIRECTIONAL GYRO -- TROUBLESHOOTING

1. Troubleshooting Directional Gyro

| TROUBLE | PROBABLE CAUSE | REMEDY |
|-----------------------------------|--|--|
| Excess drift in either direction. | Setting error. | Reset gyro. |
| | Defective instrument. | Replace instrument. |
| | High or low vacuum. If vacuum is not correct check for the following: | |
| | a. Relief valve improperly adjusted. | a. Adjust. |
| | b. Incorrect gauge reading. | b. Replace gauge. |
| | c. Pump failure. | c. Repair or replace. |
| | d. Vacuum line kinked or leaking. | d. Check and repair. Check for collapsed inner wall of hose. |
| | e. Dirty filters | e. Replace filters. |
| Dial spins during turn. | Limits (55° bank) of gimbal exceeded. | Recage gyro in flight. |
| Dial spins continuously. | Defective mechanism. | Replace instrument. |

DIRECTIONAL GYRO - MAINTENANCE PRACTICES

1. Removal/Installation of Directional Gyro

A. Remove Directional Gyro

- (1) Remove screws securing deck assembly to instrument panel.
- (2) Raise deck assembly and tape to windshield.
- (3) Disconnect lines from fittings on back of gyro.
- (4) Disconnect electrical connector from back of gyro on aircraft equipped with automatic pilot.
- (5) Remove reset knob (two knobs if aircraft equipped with automatic pilot.)
- (6) Remove three mounting screws and slide gyro backward out of instrument panel.

B. Install Directional Gyro

- (1) Position directional gyro in place on instrument panel and install three mounting screws.
- (2) Install reset knob (two knobs) if aircraft is equipped with automatic pilot.
- (3) Connect electrical connector to back of gyro on aircraft equipped with automatic pilot.
- (4) Connect lines to fittings on back of gyro.
- (5) Position deck assembly in place and install screws securing deck assembly to instrument panel.

ATTITUDE GYRO - DESCRIPTION/OPERATION

1. General

The attitude gyro (Figure 1) located on the instrument panel is essentially an air driven gyroscope rotating in a horizontal plane and is operated by the same principal as the directional gyro. Due to the gyroscopic inertia, the spin axis continues to point in the vertical direction, providing a constant visual reference to the attitude of the aircraft relative to pitch and roll axis. A bar across the face of the indicator represents the horizon and aligning the miniature aircraft to the horizon bar simulates the alignment of the aircraft to the actual horizon. Any deviation simulates the deviation of the aircraft from the true horizon. The attitude gyro is marked for different degrees of bank.

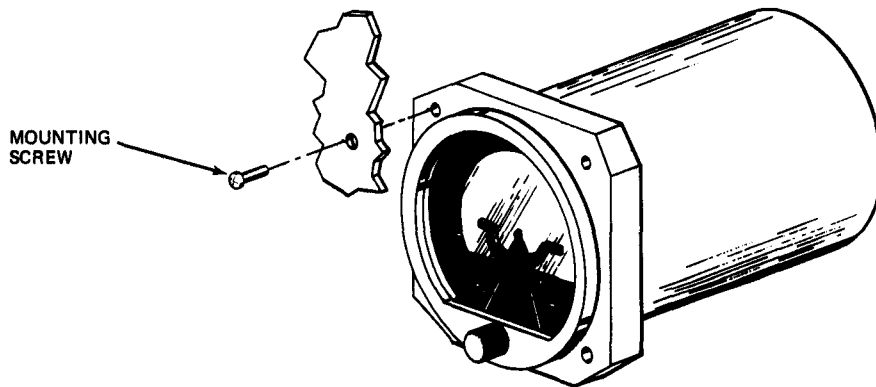

3349

Attitude Gyro
Figure 1

ATTITUDE GYRO – TROUBLESHOOTING

1. Troubleshooting the Attitude Gyro

| TROUBLE | PROBABLE CAUSE | REMEDY |
|--|--------------------------------------|-------------------------------------|
| Bar fails to respond. | Insufficient vacuum. | Check pump and tubing. |
| | Filters dirty. | Replace filter. |
| Bar does not settle. | Insufficient vacuum. | Check line and pump. Adjust valve. |
| | Incorrect instrument. | Check part number. |
| | Defective instrument. | Replace. |
| Bar oscillates or shimmies continuously. | Instrument loose in panel. | Tighten mounting screws. |
| | Vacuum too high. | Adjust valve. |
| | Defective mechanism. | Replace instrument. |
| Instrument does not indicate level flight. | Instrument not level in panel. | Loosen screws and level instrument. |
| | Aircraft out of trim. | Trim aircraft. |
| Instrument tumbles in flight. | Low vacuum. | Reset regulator. |
| | Dirty filters. | Replace filters. |
| | Line to filter restricted. | Replace line. |
| | Plug missing or loose in instrument. | Replace or tighten plug. |

ATTITUDE GYRO - MAINTENANCE PRACTICES

1. Removal/Installation of Attitude Gyro

A. Remove Attitude Gyro.

- (1) Remove screws securing deck assembly to instrument panel.
- (2) Raise deck assembly and tape to windshield.
- (3) Loosen clamps and disconnect lines from gyro.
- (4) On aircraft equipped with automatic pilot, disconnect electrical plug from gyro.
- (5) Remove the four mounting screws that secures gyro to instrument panel and remove gyro.

B. Install Attitude Gyro

- (1) Position attitude gyro in place on instrument panel and install four mounting screws.
- (2) Connect electrical plug to gyro on aircraft equipped with automatic pilot.
- (3) Connect lines and install clamps in place at back of gyro.
- (4) Position deck assembly in place and install screws securing deck assembly to instrument panel.

TURN AND BANK INDICATOR - DESCRIPTION/OPERATION

1. General

The turn and bank indicator (Figure 1) located on the instrument panel is electrically driven, therefore it will only operate when the master switch is on. The turn portion of the indicator is a gyroscope, while the bank portion of the indicator is a ball sealed in a curved glass tube filled with damping fluid. There are two styles of this unit. The first is the old style with a vertical needle in the center of the dial. This instrument reads only the rate of turn, and unless the aircraft is turning the needle will not move, regardless of bank angle. The other style is the turn coordinator which indicates both the rate of turn and rate of roll. With this type indicator, when the aircraft is rolled right and left rapidly the indicator will move, indicating a turn, but if the aircraft is held in a bank and rudder is applied the indicator will come back to zero indicating no turn.

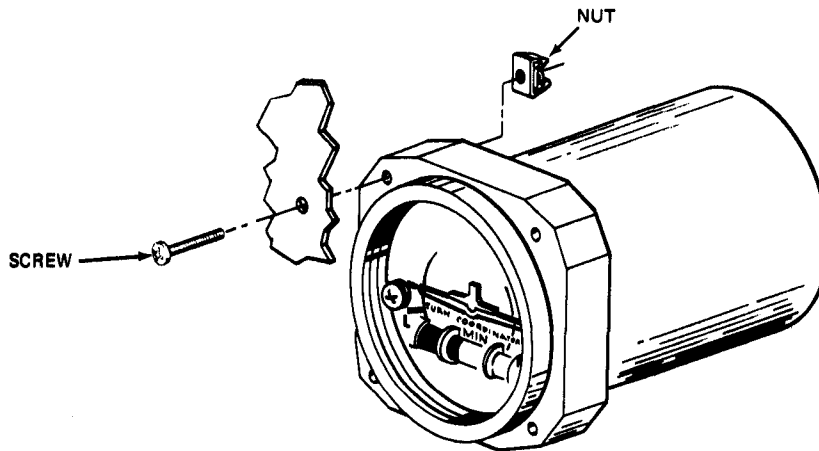

3343

Turn and Bank Indicator
Figure 1

TURN AND BANK INDICATOR – TROUBLESHOOTING

1. Troubleshooting Turn and Bank Indicator

| TROUBLE | PROBABLE CAUSE | REMEDY |
|--|--------------------------------------|-------------------------|
| Pointer fails to respond. | Foreign matter lodged in instrument. | Replace instrument. |
| | Master switch OFF. | Place master switch ON. |
| | Blown fuse. | Replace fuse. |
| Incorrect sensitivity. | Out of calibration. | Replace instrument. |
| | Aircraft not in coordinated turn. | Center ball in turn. |
| Ball sticky. | Flat spot on ball. | Replace instrument. |
| Ball not in center when aircraft is correctly trimmed. | Instrument not level in panel. | Level instrument. |

TURN AND BANK INDICATOR - MAINTENANCE PRACTICES

1. Removal/Installation of Turn and Bank Indicator

A. Remove Turn and Bank Indicator.

- (1) Remove screws securing deck assembly to instrument panel.
- (2) Raise deck assembly and tape to windshield.
- (3) Disconnect electrical plug from indicator.
- (4) Remove the four mounting screws and nuts that secure indicator to instrument panel and remove indicator.

B. Install Turn and Bank Indicator

- (1) Position turn and bank indicator in place on instrument panel and install the four mounting screws and nuts.
- (2) Connect electrical lead to rear of indicator.
- (3) Position deck assembly in place and install screws securing deck assembly to instrument panel.

MAGNETIC COMPASS - DESCRIPTION/OPERATION

1. General

The magnetic compass (Figure 1), located either on the instrument panel or the top center of the windshield frame is the liquid-filled, compensating type, incorporating two adjustable magnets. No maintenance is required for the magnetic compass except to swing it on a compass rose. Adjustments may be made to the instrument by the two screws located on the front face using a non-magnetic screwdriver of brass, aluminum, or non-magnetic stainless steel. The compass correction card is located in the card holder mounted on the instrument.

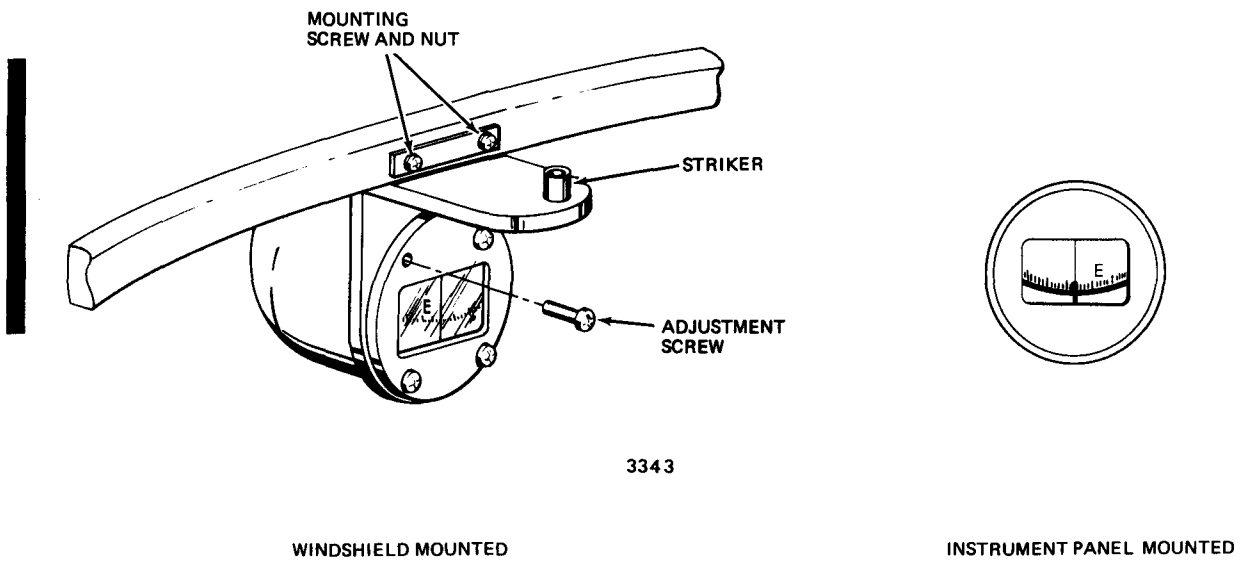

Magnetic Compass
Figure 1

MAGNETIC COMPASS — TROUBLESHOOTING

1. Troubleshooting the Magnetic Compass

| TROUBLE | PROBABLE CAUSE | REMEDY |
|---|--|---|
| Excessive card error. | Compass not properly compensated. | Compensate instrument. |
| | External magnetic interference. | Locate magnetic interference and eliminate if possible. |
| Excessive card oscillation. Card sluggish. | Insufficient liquid. | Replace instrument. |
| | Weak card magnet. | Replace instrument. |
| | Excessive pivot friction or broken jewel. | Replace instrument. |
| Liquid leakage. | Loose bezel screws. | Replace instrument. |
| | Broken cover glass. | Replace instrument. |
| | Defective sealing gaskets. | Replace instrument. |
| Discolored markings. Defective light. | Age. | Replace instrument. |
| | Burned out lamp or broken circuit. | Check lamp or continuity of wiring. |
| Card sticks. | Altitude compensating diaphragm collapsed. | Replace instrument. |
| Card does not move when compensating screws are turned. | The gears that turn compensating magnets are stripped. | Replace instrument. |

MAGNETIC COMPASS - MAINTENANCE PRACTICES

1. Removal/Installation of Magnetic Compass

A. Remove Magnetic Compass.

- (1) Remove two mounting screws and nuts.
- (2) Disconnect electrical lead and remove compass.

B. Install Magnetic Compass

- (1) Connect electrical lead to magnetic compass.
- (2) Position magnetic compass in place and install mounting screws and nuts.

**AA-5 SERIES
MAINTENANCE MANUAL**

TRANSPONDER — DESCRIPTION/OPERATION

1. **General**

The transponder is radar beacon equipment designed to fulfill the role of the airborne beacon under the requirements of the Air Traffic Control Radar Beacon System (ATCRBS).

The use of the transponder enables the air traffic controller to identify the aircraft and therefore provides more positive control. Range and azimuth are established by the return from the transponder's pulsed transmitter in reply to a routing interrogation from the ground radar site.

The transponder reply is a set of pulses, selected in number, and positioned in time, one with respect to the other. Information is conveyed to the ground in this manner. An identity code number, selected at the front panel by the pilot is transmitted as a Mode A reply. Mode C, altitude reporting, is an additional capability designed into the transponder. However, in order to convey altitude information, the transponder must be used in conjunction with an altimeter and be operated in "ALT" mode.

An additional feature of the transponder and beacon system is the S.P.I. (Special Pulse, Identification). After pressing the ident button the transponder, when interrogated, will reply with a special pulse that will cause the associated pip on the controllers display to "bloom" effecting immediate recognition.

All operating controls for the transponder are mounted on its front panel. Many AA-5, AA-5A, and AA-5B aircraft are equipped with either a NARCO 50A/AT-150, KING KT76/KT78A or COLLINS TDR-950/950L transponder. Operating controls for both models are shown in Figures 1 and 2. NARCO AT-150, KING KT-78A, and COLLINS TDR-950/950L transponder available on 1978 model AA-5A and AA-5B.

AA-5 SERIES
MAINTENANCE MANUAL

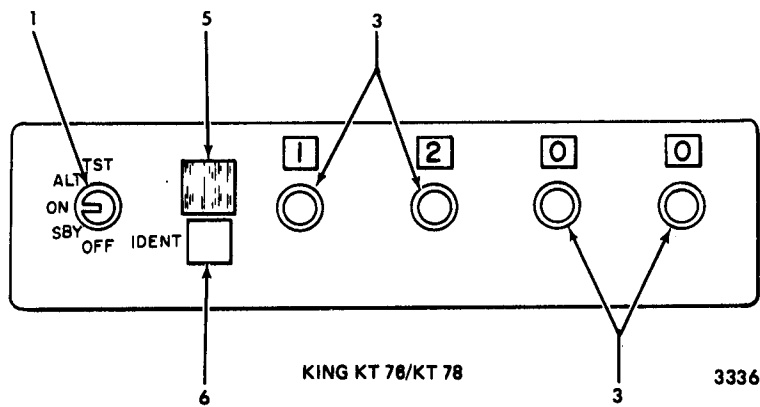
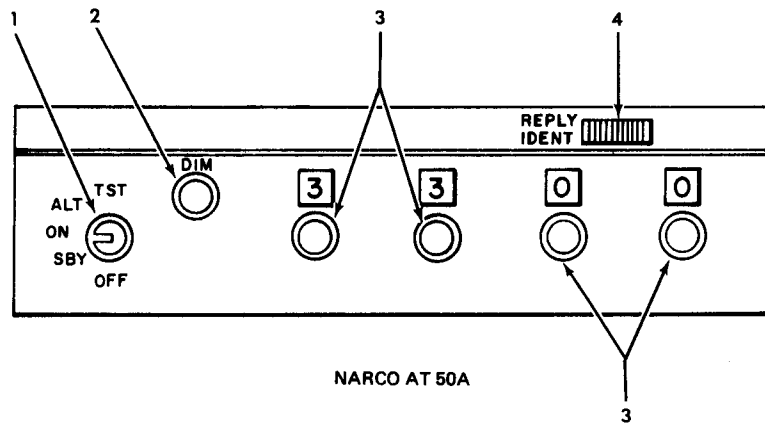

- | | |
|----------------------|-----------------------------------|
| 1. Function Selector | 4. Monitor Light and Ident Button |
| 2. Dim Control | 5. Monitor Light |
| 3. Code Selectors | 6. Ident Button |

Transponders
Figure 1

AA-5 SERIES
MAINTENANCE MANUAL

1. Function Selector
2. DIM/IDENT Control
(Pull for Ident)
3. Code Selector

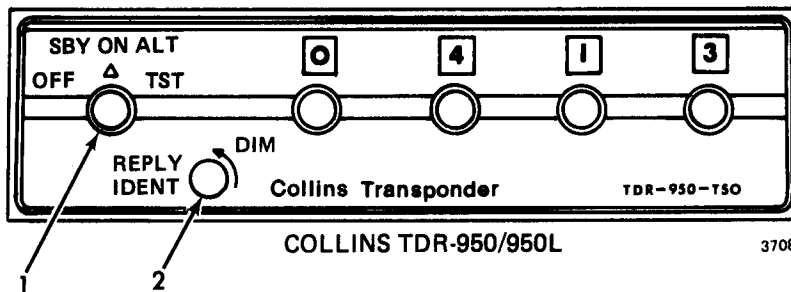
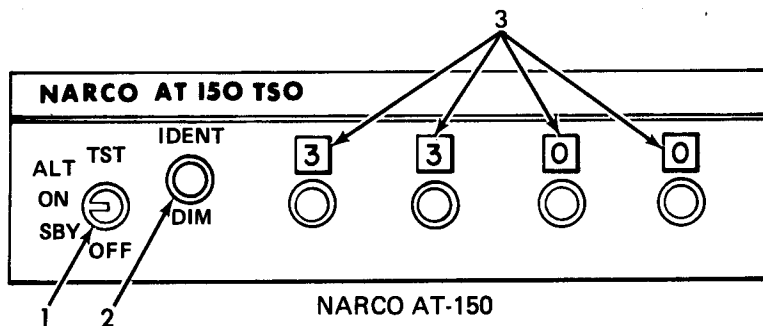

Transponders
Figure 2

TRANSPONDER — MAINTENANCE PRACTICES

1. Removal/Installation of Transponder

A. Remove Transponder

- (1) Ensure that master power switch is in the OFF position.
- (2) Locate transponder in avionics panel on the instrument panel.
- (3) Turn locking (allen) screw clockwise to release transponder unit from its mounting case. Use 5/64 inch hex (allen) wrench.

CAUTION: DO NOT PULL TRANSPONDER FREE OF MOUNT BY GRASPING THE CONTROL KNOBS.

- (4) Grasp the body of the transponder and carefully slide transponder from avionics panel mount. A slight left to right movement might help in disconnecting unit from connector plug.

B. Install Transponder

- (1) Ensure that master power switch is in the OFF position.
- (2) Grasp the transponder by the sides and carefully slide transponder into avionics panel mount until plug connection is fully engaged.
- (3) Turn locking (allen) screw counterclockwise to secure transponder unit to its mounting case. Use 5/64 inch hex (allen) wrench.

2. Removal/Installation of Transponder Antenna

A. Remove Transponder Antenna (Figure 201).

- (1) Ensure that master power switch is in the OFF position.
- (2) Locate transponder antenna forward of center spar (Station 90).
- (3) Disconnect coax cable from antenna.
- (4) With phenolic scraper, remove sealant from around nut which secures antenna to fuselage.
- (5) Loosen nut and remove antenna.

B. Install Transponder Antenna

- (1) Ensure Master switch is OFF.
- (2) Position transponder antenna into mounting hole located at fuselage Station 90.
- (3) Install nut securing antenna to the fuselage.
- (4) Apply Presstite putty sealant around attaching nut.
- (5) Connect coax cable to antenna.

AA-5 SERIES
MAINTENANCE MANUAL

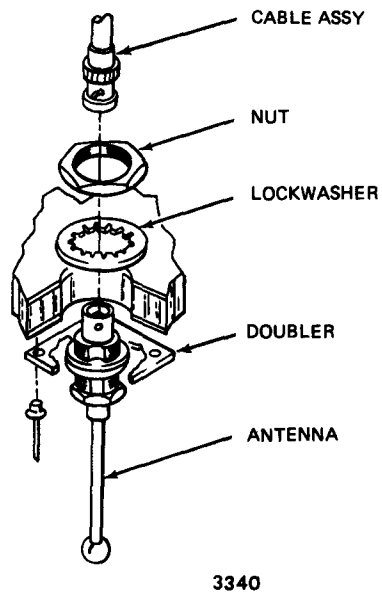

Transponder Antenna Installation
Figure 201

**AA-5 SERIES
MAINTENANCE MANUAL**

ADF SYSTEM — DESCRIPTION/OPERATION

1. General

The automatic direction finder (ADF) system consists of a receiver, an indicator, R.F.I. filter, antennas, related cables, and associated wiring. The receiver and the indicator is located on the instrument panel. All operating controls for the ADF are located on the front of the receiver and the indicator.

Several different models of ADF equipment are available for installation in the aircraft. Three different models are described in this section.

2. NARCO ADF 140/ADF 141 Automatic Direction Finder with ADF 101 Indicator

The NARCO ADF 140/ADF 141 automatic direction finder, Figure 1, is an airborne radio receiver that indicates the relative direction to the station to which it is tuned. The ADF 140/141 receives and detects the radio signal, and the bearing information is displayed on the ADF 101 indicator. ADF 141 available on 1978 model AA-5A and AA-5B.

The ADF receives signals in the frequency range of 200-1799 KHz with individual frequencies in increments of 1 KHz.

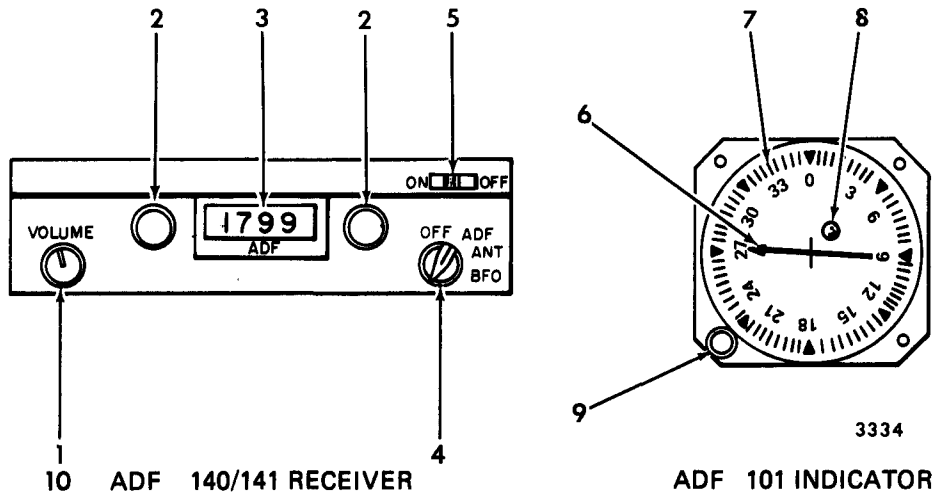

- | | |
|------------------------|----------------------------|
| 1. Volume Control | 6. Bearing Indicator |
| 2. Frequency Selectors | 7. Bearing Scale |
| 3. Frequency Indicator | 8. Low Level Signal Light |
| 4. Function Switch | 9. Rotation/Test Knob |
| 5. Ident Switch | 10. Volume/Ident (ADF 141) |

NARCO ADF 140/ADF 101 Automatic Direction Finder
Figure 1

**AA-5 SERIES
MAINTENANCE MANUAL**

3. KING KR85/KI 225 Automatic Direction Finder

The KING KR 85 automatic direction finder (Figure 2) is a solid state receiver which provides an aural reception and bearing information capability within the frequency range of 200 KHz to 1699 KHz. The channels may be selected in 1 KHz increments. The KR 85 is capable of automatic needle stowage. This is, when the radio is turned to the "ANT" function, the needle automatically seeks the 90° position and then turns off the servo system so that all pointing functions are discontinued.

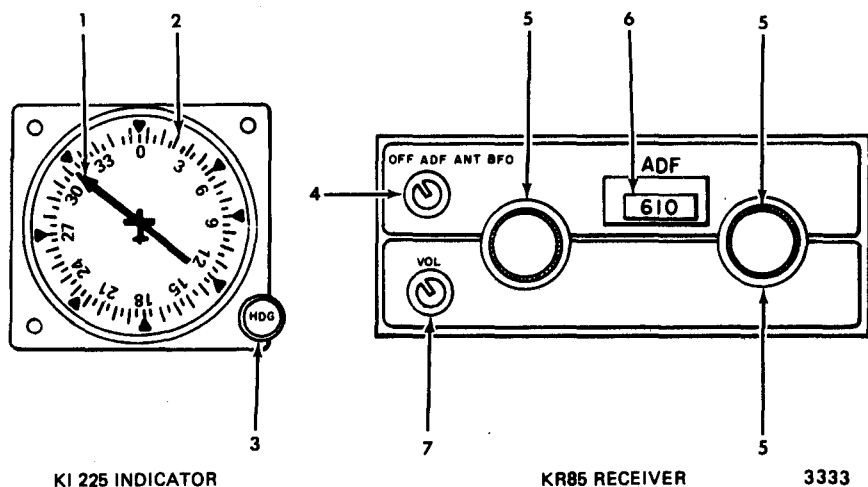

- | | |
|-------------------------|-----------------------|
| 1. ADF Pointer | 5. Frequency Selector |
| 2. Index Rotatable Card | 6. Frequency Display |
| 3. Heading Selector | 7. Volume Control |
| 4. Function Selector | |

KING KR 85/KI 225 Automatic Direction Finder
Figure 2

4. COLLINS ADF 650/IND-650 Automatic Direction Finder (See Figure 3.)

The COLLINS ADF-650 is a solid state receiver which operates within the frequency range of 200 KHz and 1799 KHz. Frequency selection is made using the three control knobs located on the front of the unit. If the desired station has an identification tone, pull the VOL/ID control out for reception of ID signal. The ANT mode will provide the clearest reception of station ident. This equipment is available on 1978 Model AA-5A and AA-5B.

Pressing the test button while in ADF mode will cause the indicator pointer to rotate 90 degrees from its prior position if the ADF-650 system is operating properly.

AA-5 SERIES
MAINTENANCE MANUAL

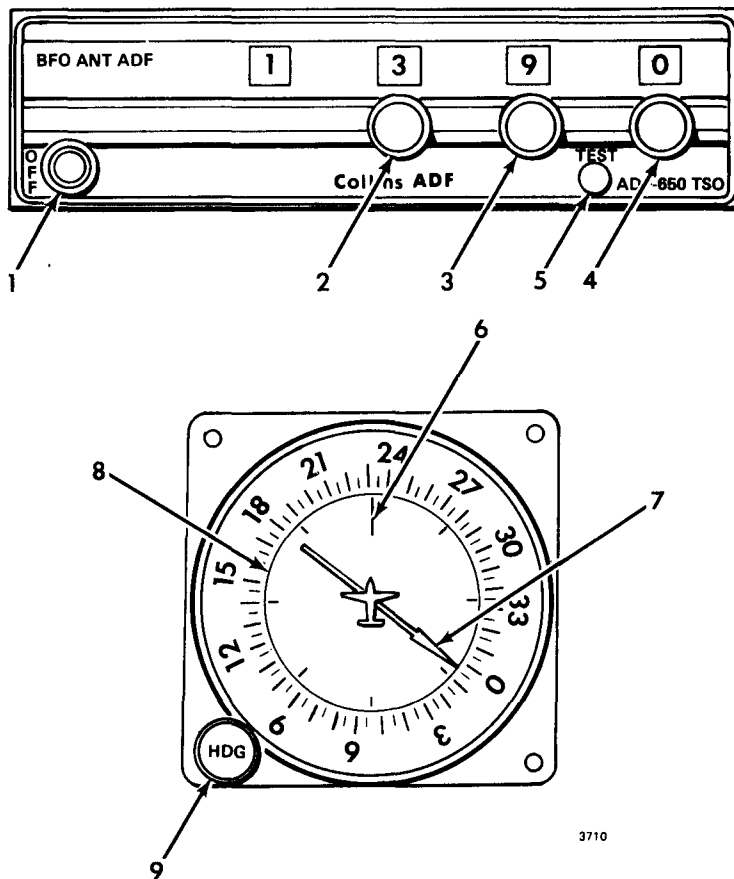

1. ON/OFF/VOL/ID Control
2. 100 KHz/1 MKz Frequency Control
3. 10 KHz Frequency Control
4. 1 KHz Frequency Control
5. Self-Test Switch
6. Lubber Line
7. ADF Bearing Pointer
8. Compass Card
9. Heading Selector

COLLINS ADF-650/IND-650 Automatic Direction Finder
Figure 3

ADF SYSTEM — MAINTENANCE PRACTICES

1. Removal/Installation of ADF Indicator

A. Remove Instrument Panel Mounted Indicator

- (1) Remove screws securing deck assembly to instrument panel.
- (2) Raise deck assembly and tape to windshield.
- (3) Disconnect electrical wiring from rear of ADF indicator.
- (4) Remove the three mounting screws securing ADF indicator to instrument panel and remove indicator.

B. Install Instrument Panel Mounted Indicator

- (1) Position indicator in place on instrument panel and install three mounting screws.
- (2) Connect electrical wiring to rear of indicator.
- (3) Position deck assembly in place and install screws securing deck assembly to instrument panel.

2. Removal/Installation of ADF Receiver

A. Remove Receiver

- (1) Ensure that master power switch is in the OFF position.
- (2) Locate ADF receiver in avionics panel on the instrument panel.
- (3) Loosen ADF receiver unit by turning locking (allen) screw clockwise. Use 5/64 inch hex (allen) wrench.

CAUTION: DO NOT PULL ADF RECEIVER FREE FROM INSTRUMENT PANEL BY GRASPING THE CONTROL KNOBS.

- (4) Pull the ADF receiver unit straight forward. Be extremely careful not to bend connector pins. A slight left to right movement might help to release unit from connector plug.

B. Install Receiver

- (1) Ensure that master power switch is OFF.
- (2) Slide ADF receiver unit into mounting position on instrument panel. Be extremely careful not to bend connector pins.
- (3) Secure ADF receiver unit to mounting case by turning locking (allen) screw counterclockwise. Use 5/64 inch hex (allen) wrench.

3. Removal/Installation of ADF Loop Antenna

A. Remove ADF Loop Antenna (See Figure 201.)

NOTE: This procedure is typical for ADF equipment furnished by either NARCO or KING.

- (1) Ensure master power switch is OFF.
- (2) Locate ADF loop antenna on bottom of fuselage at station 147.1.
- (3) Remove two screws attaching loop antenna to fuselage and loop cable and plate assembly.

AA-5 SERIES
MAINTENANCE MANUAL

- (4) Disconnect loop antenna from loop cable.
- (5) Remove two screws attaching loop cable and plate assembly to fuselage.
- (6) Remove carpet and access cover on baggage compartment floor.
- (7) Through access opening, remove loop cable and plate assembly.

B. Install ADF Loop Antenna

- (1) Ensure that master power switch is in the OFF position.
- (2) Through access hole in baggage compartment floor, align loop cable and plate assembly with holes in fuselage floor at Station 147.1. Make sure arrow on plate points to the forward end of aircraft.
- (3) On outside of fuselage, install two screws attaching loop cable and plate assembly to fuselage.
- (4) Making sure arrow on loop antenna points to the forward end of the aircraft, plug loop antenna into loop cable receptacle.
- (5) Install two screws attaching loop antenna to fuselage and plate assembly.
- (6) Install access cover to baggage compartment floor and secure carpet to floor.

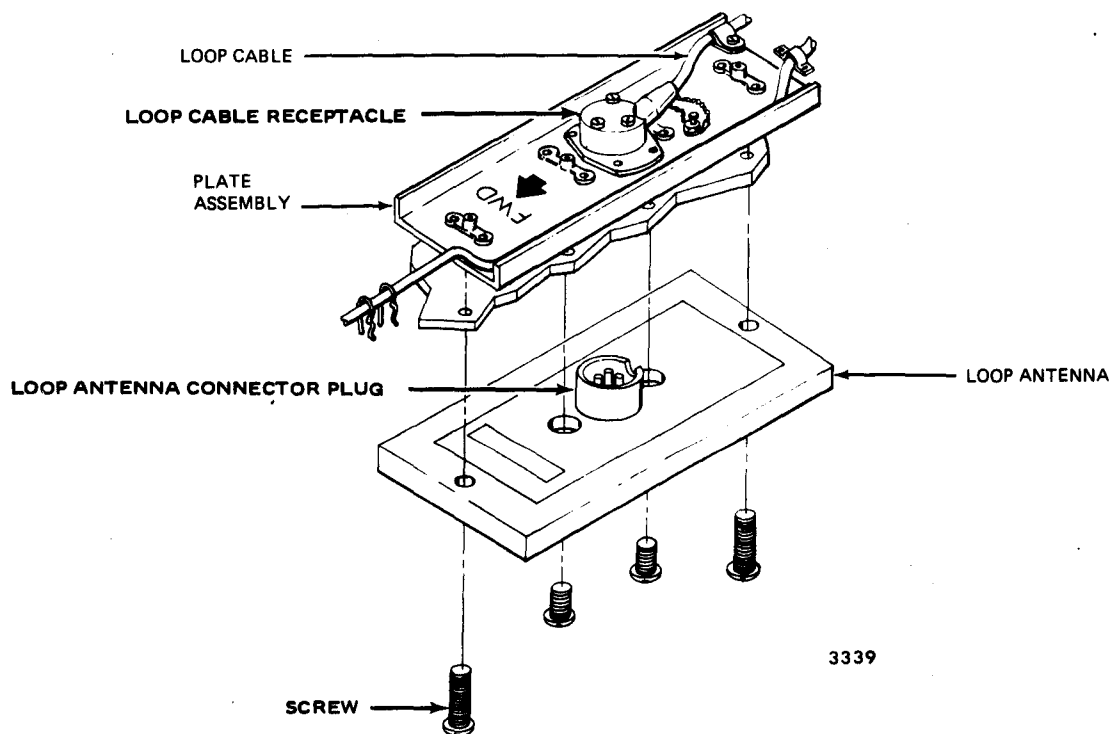

ADF Loop Antenna Installation
Figure 201

DME SYSTEM — DESCRIPTION/OPERATION

1. General

A typical Distance Measuring Equipment (DME) system consists of a panel mounted 200 channel UHF transmitter-receiver and an externally mounted antenna. The transceiver has a single selector knob that changes the DME's mode of operation to provide the pilot with: distance-to-station, time-to-station, or ground speed readouts. The DME is designed to operate in altitudes up to a maximum of 50,000 feet at ground speeds up to 250 knots and has a maximum slant range of 199.9 nautical miles. Depending upon type of equipment installed it is possible to channel DME system from a remote location.

All operating controls for the DME are mounted on its front panel. The DME 190 shown in Figure 1 depicts a typical installation.

AA-5 SERIES
MAINTENANCE MANUAL

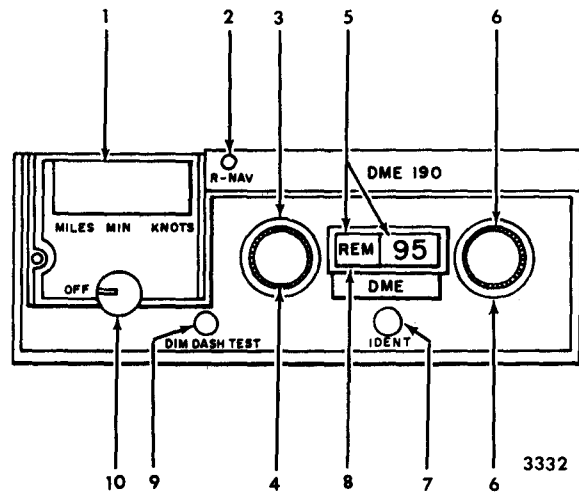

- | | |
|---|--|
| 1. Readout Window | 6. Fractional Megahertz Selector Knobs |
| 2. R-NAV Indicator Lamp | 7. Ident Volume |
| 3. Remote Channeling Selector (When Modified for R-NAV operation) | 8. Indicates Remote Tuning (When modified for R-NAV operation) |
| 4. Whole Megahertz Selector Knob | 9. Dim/Push Test Knob |
| 5. Frequency Indicator | 10. Mode Selector Switch |

NARCO DME 190 Distance Measuring Equipment
Figure 1

DME SYSTEM - MAINTENANCE PRACTICES

1. Removal/Installation of DME Transmitter-Receiver

A. Remove DME Transmitter-Receiver

- (1) Locate DME transmitter-receiver in instrument panel.
- (2) Ensure that master power switch is OFF.
- (3) Turn locking (allen) screw clockwise to release DME unit from its mounting case. Use 5/64 inch hex (allen) wrench.

CAUTION: DO NOT PULL DME TRANSMITTER-RECEIVER FREE OF MOUNT BY GRASPING THE CONTROL KNOBS.

- (4) Grasp the body of the transmitter-receiver and with a slight rocking motion while pulling outward, free receiver from connector plug and slide receiver from instrument panel mount.

B. Install DME Transmitter-Receiver

- (1) Ensure that master power switch is OFF.
- (2) Grasp the transmitter-receiver by the sides and carefully slide transmitter-receiver into instrument panel mount until connector plug is fully engaged.
- (3) Turn locking (allen) screw counterclockwise to secure DME unit to its mounting case. Use 5/64 inch hex (allen) wrench.

VOR SYSTEM — DESCRIPTION/OPERATION

1. General

The primary and most widely used system of navigation in the United States today is the very high frequency omnidirectional range (VOR). The VOR system consists of both ground stations and airborne radio equipment. This chapter defines and discusses the airborne portion of the system only. A more detailed coverage of the use and procedures applicable to the VOR system is presented in the manufacturer's technical data.

The VOR receivers exist in a variety of forms. One type now in use is the NAV/COM set which combines both the communication and navigation functions. One part of this set is a radio transceiver, the other a navigation receiver with a separate VOR indicator.

Other sets in use incorporate a receiver with an indicator built into the control panel as an integral part of the set. Another widely used unit is the combination VOR receiver and indicator. The AA-5, AA-5A, and AA-5B uses equipment distributed by different manufacturers. The NARCO, KING, and COLLINS VOR receivers and indicators are described in this section.

2. KING KX 107B/175B NAV/COM Transceiver

The KING KX 170B/KX 175B NAV/COM combines in a single panel mounted unit a 720 channel VHF COM transceiver and an independent 200 channel VHF NAV receiver. The NAV receiver supplies VOR/LOC information to navigational converters and provides frequency selection for remote mounted distance measuring equipment and glideslope receivers.

All operating controls for the transceiver are mounted on the front panel and identified in Figure 1.

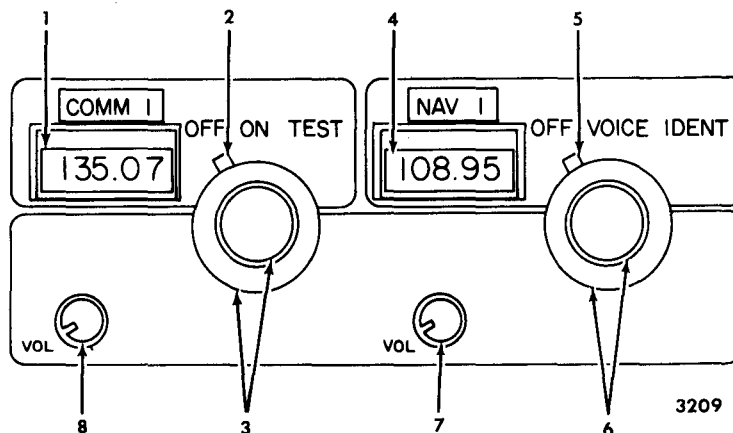

- | | |
|------------------------------------|------------------------------------|
| 1. COM Frequency Readout | 6. NAV Frequency Selector Controls |
| 2. COM ON-OFF Test Control | 7. NAV Volume Control |
| 3. COM Frequency Selector Controls | 8. COM Volume Control |
| 4. NAV Frequency Readout | |
| 5. NAV OFF-Voice-Ident Control | |

KING KX 170B/KX 175B NAV/COM Transceiver
Figure 1

3. KING VOR/LOC-GS Indicators

The KING KI 201C/VOR indicator is designed to operate with VHF navigational equipment such as the KX 170 to provide OMNI (VOR) or LOCALIZER (LOC) information. The VHF navigational receiver receives and detects the OMNI or LOCALIZER information. The KI 201C converts this information to DC signals which drive the LEFT-RIGHT needle and the TO-OFF-FROM flag of the visual indicator.

The KI 214 ILS indicator performs the same functions as the KI 201C. In addition, it contains a 40 channel glide-slope receiver and the visual indicators include an UP-DOWN glideslope needle with an OFF warning flag.

All operating controls for the indicator are mounted on the front panel and are identified in Figure 2.

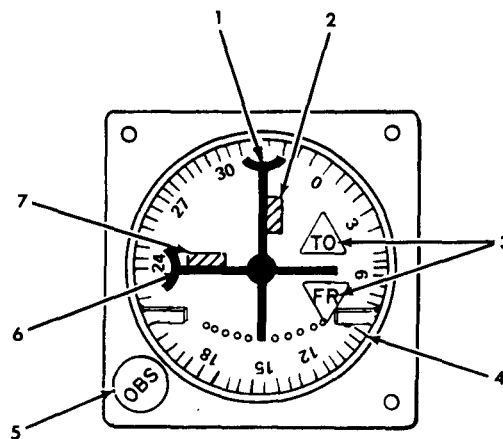

1. VOR/LOC Deviation Indicator
2. VOR/LOC Warning Flag
3. To-From Flag
4. Azimuth Card
5. OBS Knob
6. Glideslope Needle (KI-214)
7. Glideslope Warning Flag (KI-214)

KING KI 201C/VOR/LOC-GS Indicator
Figure 2

The KING KI-203 and KI-208 are designed for use with KX-175B transceiver to provide VOR/LOC information. The navigational receiver portion of the KX-175B receives and detects the VOR and localizer frequencies. The KI-203 and KI-208 converts the information to DC signals which drive the LEFT-RIGHT and the TO-NAV-FROM flag of the visual indicator.

**AA-5 SERIES
MAINTENANCE MANUAL**

The KING KI-204 and KI-209 provide the same information as the KI-203 and KI-208. In addition, it can accept the information from the glideslope receiver to provide full ILS information. The glideslope receiver drives the UP-DOWN glideslope needle and the glideslope warning flag.

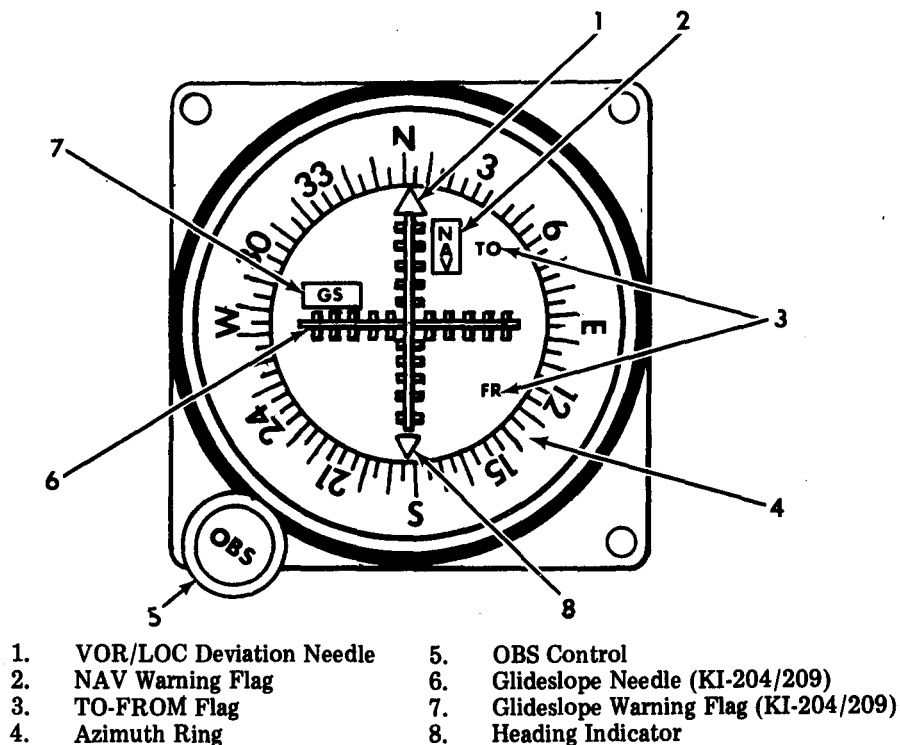

KING KI-203/204/208/209 VOR/LOC-GS Indicator
(1978 Model, AA- 5A and AA-5B)
Figure 2A

4. NARCO NAV 14 Navigation Receiver and DGO 10 Display Unit

The NAVCO NAV 14 is a fully independent NAV receiver designed to drive the DGO 10 pictorial navigation display.

The NAV 14 and DGO 10 provide the following:

- A. 200 channel navigation receiver (108.00 to 117.95 MHz).
- B. 160 channel backup communication receiver (118.00 to 125.95 MHz).
- C. Remote DME channeling capability.
- D. VOR/LOC presentation.

**AA-5 SERIES
MAINTENANCE MANUAL**

All operating controls for the NAV 14 and DGO 10 are mounted on their front panels and are identified in Figure 3.

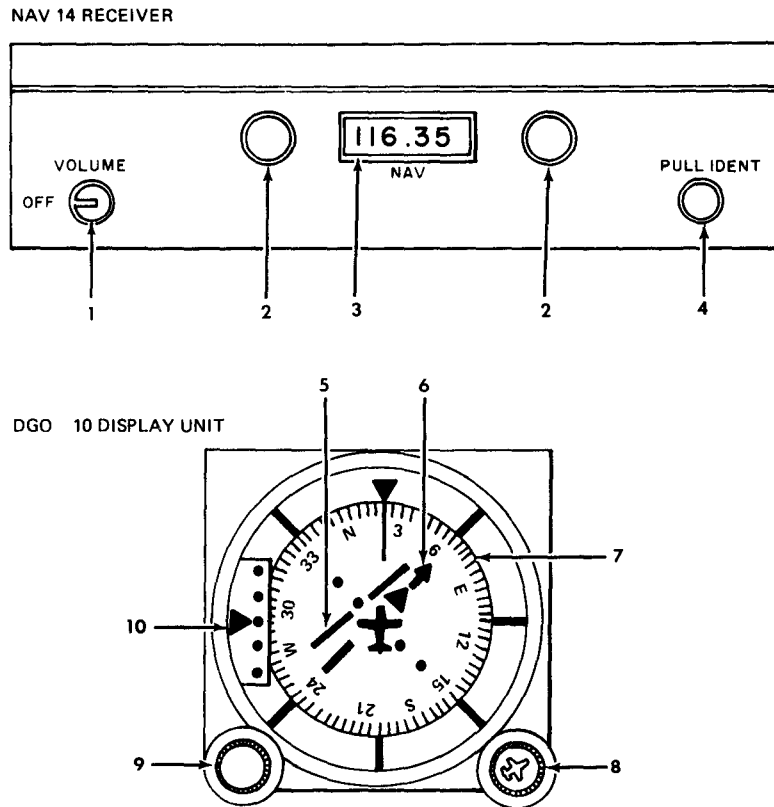

3330

- | | |
|-------------------------------|--------------------------|
| 1. Off Volume Control | 6. OBS Pointer |
| 2. Frequency Selectors | 7. Heading Scale |
| 3. Frequency Readout | 8. OBS Knob |
| 4. Ident | 9. DG Set Knob |
| 5. Course Deviation Indicator | 10. Glideslope Indicator |

NARCO NAV 14 Navigation Receiver and DGO 10 Display Unit
Figure 3

5. NARCO NAV 10/COM10 () System

The NARCO NAV 10/COM 10 () system consists of two separate panel mounted units. These units are treated as a system because the NAV 10 is dependent upon the COM 10 () for receiver circuitry. The mode of operation is determined by the function selector switch located on the COM 10 () unit. This section describes the operation of the navigation portion only, see Chapter 23 for a description of the VHF communication section.

The system is capable of receiving 200 VHF navigation channels from 108.00 MHz through 117.95 and for localizer information between 108.10 MHz and 111.95 MHz. When a VOR channel is selected the indicator needle shows left or right deviation from the chosen course. When localizer channel (frequency) is selected the indicator needle shows left or right deviation from runway center line.

All operation controls for the system are located on the front panels and are identified in figure 4.

**AA-5 SERIES
MAINTENANCE MANUAL**

NAV INDICATOR

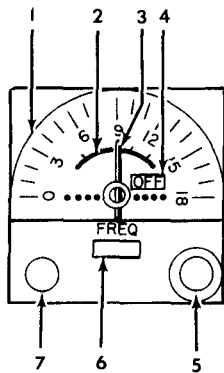

NAV/COM TRANSCEIVER

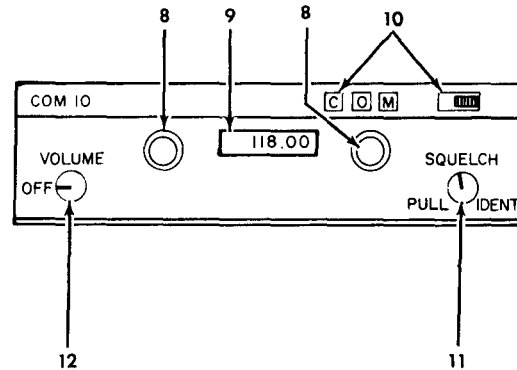

3207

- | | |
|--------------------------------|--------------------------------|
| 1. Azimuth Card | 7. OMNI Bearing Selector |
| 2. Reciprocal Card | 8. Com Frequency Selector Knob |
| 3. VOR/LOC Deviation Indicator | 9. Frequency Readout |
| 4. OFF-TO-FROM Indicator | 10. NAV/COM Function Selector |
| 5. NAV Frequency Selector | 11. Squelch |
| 6. NAV Frequency Indicator | 12. Volume Control |

NARCO NAV 10/COM 10 () Units
Figure 4

6. NARCO NAV 11-NAV 12 Navigation System Unit

The NARCO NAV 11-NAV 12 navigation system consists of a panel-mounted unit that provides navigational information. The NAV 11 and NAV 12 systems are similar with regard to VOR reception. The NAV 12 system has the added capability of receiving and displaying glideslope information to enable full ILS approaches rather than the localizer only approaches possible with the NAV 11.

The NAV 11 system receives and displays VOR stations as follows: Even tenths between 108.00 and 111.85 MHz and all channels 112.00 through 117.95 MHz. In addition, it receives and displays localizer channels (odd tenths, 108.10 through 111.95 MHz).

The NAV 12 system receives and displays the same VOR and ILS localizer signals as the NAV 11 system. In addition, the NAV 12 system receives and displays the UHF glide slope signals to provide full ILS approach display.

All operating controls for the navigation system are located on its front panel and are identified in Figure 5.

AA-5 SERIES
MAINTENANCE MANUAL

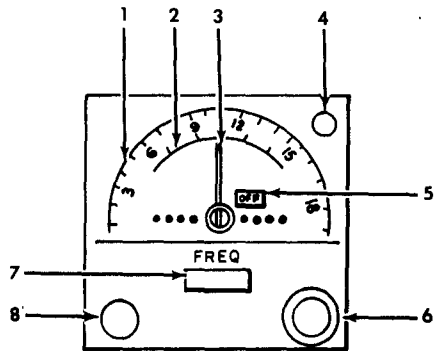

NAV 11 UNIT

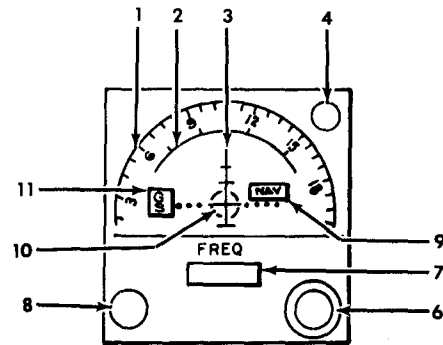

3329

NAV 12 UNIT

- | | |
|--------------------------------|--------------------------|
| 1. Azimuth Card | 8. OMNI Bearing Selector |
| 2. Reciprocal Card | 9. NAV-TO-FROM Indicator |
| 3. VOR/LOC Deviation Indicator | 10. Glideslope Indicator |
| 4. VOL-ID Control | 11. Glideslope Flag |
| 5. OFF-TO-FROM Indicator | |
| 6. Frequency Selector | |
| 7. Frequency Indicator | |

NARCO NAV 11 NAV 12 Navigation System Units
Figure 5

AA-5 SERIES
MAINTENANCE MANUAL

7. NARCO NAV 121-NAV 122 Navigation System (1978 Model, AA-5A and AA-5B)

The NAV 121 is a completely self contained VOR/LOC receiver and indicator. The NAV 122 is identical to the NAV 121 with the addition of a glideslope receiver and glideslope display.

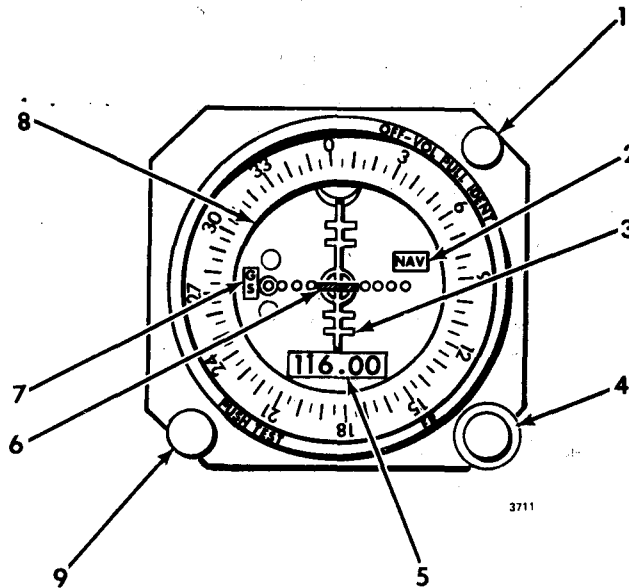

1. OFF-VOL Control
(Pull for station IDENT)
2. NAV-TO-FROM Flag
3. VOR/LOC Deviation Needle
4. Frequency Control
5. Frequency Indicator
6. Glideslope Deviation Needle (NAV-122)
7. Glideslope Warning Flag (NAV-122)
8. Compass Ring
9. Omni Bearing Selector (OBS)

NARCO NAV 121-NAV 122 Navigation System
(1978 Model, AA-5A and AA-5B)
Figure 6

**AA-5 SERIES
MAINTENANCE MANUAL**

8. COLLINS Navigation System (1978 Model, AA-5A and AA-5B)

The units used in the COLLINS navigation system are the VIR-350, VIR-351, GLS-350, IND-350, and IND-351.

The VIR-350 (Figure 7) NAV receiver can be used with the IND-350 or IND-351 to display VOR or LOC information. Station frequency selection is made with the frequency control. If the VOR station has an IDENT code, the tone can be heard by pulling the VOL control out. The VIR-350 NAV receiver can be used with the GLS-350 glide-slope receiver and the IND-351 to provide glideslope information.

The VIR-351 (Figure 8) NAV receiver will perform the same function as the VIR-350 plus will give a digital readout of the bearing of the selected VOR station. The VOR station frequency selection is made with the TO/FREQ/FROM control in the FREQ position. The selected frequency is displayed in the electronic display. The bearing of the selected VOR station is displayed in the electronic display with the TO/FREQ/FROM control in the FROM position. The bearing, in degrees, is followed by the letter F in the electronic display. The heading to the selected VOR station (radial + 180 degrees) may be displayed by selecting the TO position (no letter appears after the bearing displayed). Three dashes will appear in the electronic display if no signal is received or if a localizer frequency is selected and the control switch is in the TO or FROM position.

The IND-350 and IND-351 (Figure 9) provide a visual display for VOR/LOC indication and glideslope information (IND-351 only). The VOR/LOC deviation bar indicates the direction and amount of deviation from a selected VOR or localizer course. Appearance of the NAV flag indicates that unreliable information is being supplied to the VOR/LOC deviation bar. The glideslope deviation bar indicates the position above or below the correct glideslope. The GS flag (IND-351 only) indicates an unreliable glideslope signal when tuned to a localizer frequency.

The GLS-350 (Figure 10) glideslope receiver is used with the NAV receiver to provide glideslope information to the IND-351. The receiver is automatically tuned when the NAV receiver is tuned to a localizer frequency.

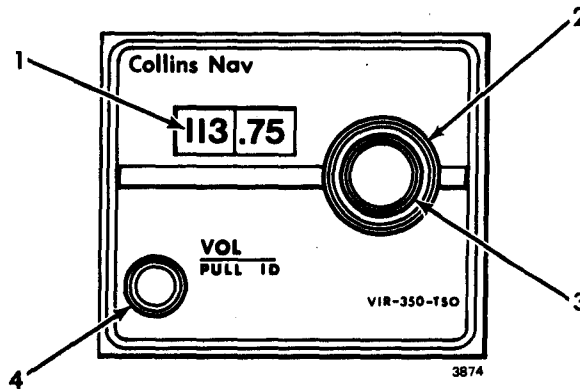

1. Frequency Display
2. MHz Frequency Selector
3. KHz frequency selector
4. ON/OFF Volume Control
(Pull for IDENT)

VIR-350 Navigation Receiver
Figure 7

**AA-5 SERIES
MAINTENANCE MANUAL**

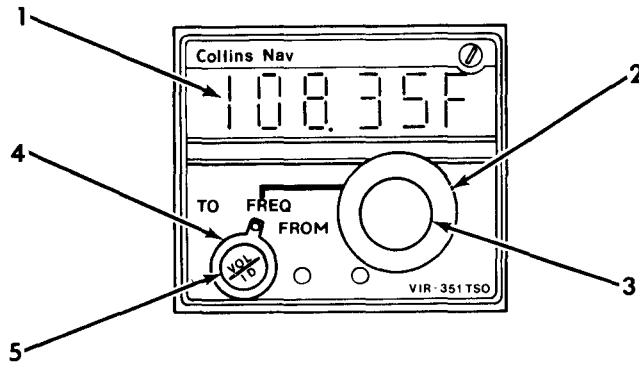

1. Electronic Display
2. MHz Frequency Selector
3. KHz Frequency Selector
4. Display Select
5. ON/OFF/VOL/ID Control
(Pull for IDENT)

VIR-351 Navigation Receiver
Figure 8

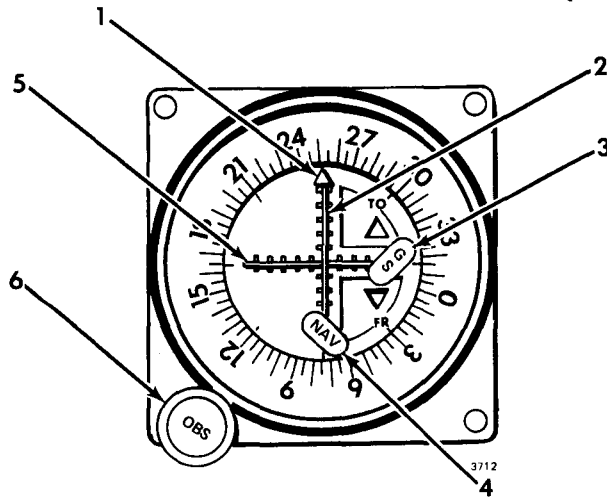

1. Course Index
2. VOR/LOC Deviation Bar
3. GS Flag (IND-351 only)
4. NAV Flag
5. Glideslope Deviation Bar
(IND-351 only)
6. Omni Bearing Selector

IND-350/351 VOR/LOC/GS Indicator
Figure 9

AA-5 SERIES
MAINTENANCE MANUAL

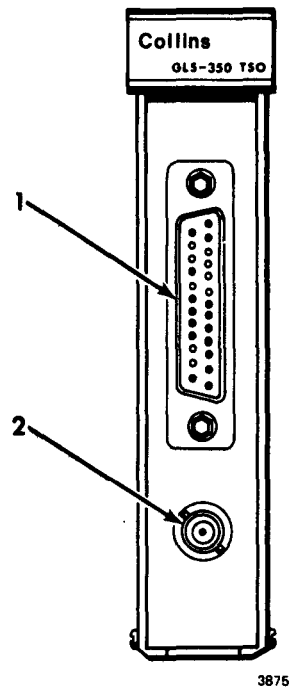

3875

1. Coax Cable Connector
2. Control Cable Connector

GLS-350 Glideslope Receiver
Figure 10

NAVIGATION (VOR) SYSTEM - MAINTENANCE PRACTICES

1. Removal/Installation of Navigation (VOR) System Units

NOTE: When removing or installing avionics equipment always ensure that the Master power switch is OFF.

A. Removal of Navigation Transceiver Unit

- (1) Locate, on the instrument panel, the transceiver used for navigation.
- (2) Turn locking (allen) screw clockwise to release transceiver unit from its mounting case. Use 5/64 hex (allen) wrench.
- (3) Pull unit straight out. Be extremely careful not to bend connector pins. A slight left to right movement might help to release unit from connector plug.

NOTE: Do not use front panel controls as handles in removing unit from instrument panels.

B. Installation of Navigation Transceiver Unit

- (1) Slide the transceiver unit straight forward into its mounting case. Ensure connector plug is fully engaged. Be extremely careful not to bend connector pins.
- (2) Turn locking (allen) screw counterclockwise to secure transceiver unit to its mounting case. Use 5/64 inch hex (allen) wrench.

C. Removal of Navigation (OMNI head) Unit

- (1) Remove screws securing deck assembly to instrument panel.
- (2) Raise deck assembly and tape to windshield.
- (3) Disconnect electrical plug from rear of navigation unit that is to be removed.
- (4) Remove the mounting hardware securing navigation unit to instrument panel.
- (5) Remove navigation unit.

D. Installation of Navigation (OMNI head) Unit

- (1) Position navigation unit in place on instrument panel and install mounting hardware securing unit to instrument panel.
- (2) Connect electrical plug to rear of navigation unit.
- (3) Position deck assembly in place and install screws securing deck assembly to instrument panel.

2. Removal of NAV Antenna (Figure 201)

A. Removal of NAV antenna (Figure 201)

- (1) Ensure the master power switch is OFF.
- (2) Remove rudder tip, to gain access to NAV antenna connections.

NOTE: Be careful not to damage flashing beacon assembly.

- (3) Locate NAV antenna at top of vertical stabilizer.

AA-5 SERIES
MAINTENANCE MANUAL

- (4) Disconnect cable assembly from antenna rods, and remove rods.

NOTE: Do not allow cable assembly to drop down inside vertical stabilizer.

B. Installation of NAV Antenna

- (1) Ensure the master power switch is OFF.
- (2) Insert antenna rod ends into mounting block.
- (3) Connect cable assembly to antenna rods.
- (4) Replace rudder tip.

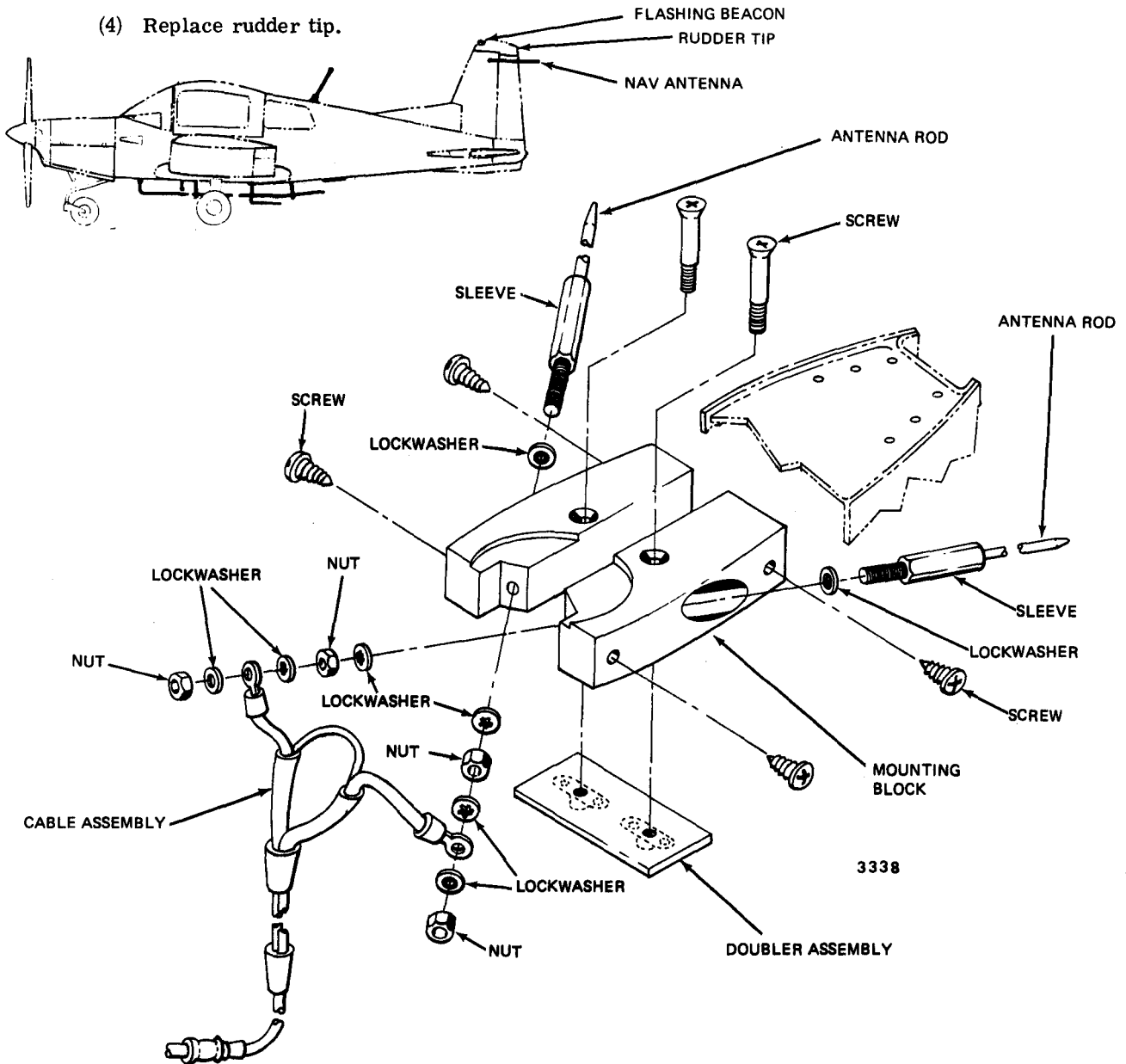

NAV Antenna Installation
Figure 201

AA-5 SERIES
MAINTENANCE MANUAL

CHAPTER 37
VACUUM SYSTEM
TABLE OF CONTENTS

| <u>NUMBER</u> | | <u>PAGE</u> |
|---------------|--------------------------------------|-------------|
| 37-0 | VACUUM SYSTEM | |
| | Description/Operation | 1 |
| | General | 1 |
| | Troubleshooting | 101 |
| | Maintenance Practices | 201 |
| | Adjustment/Test | 201 |
| 37-1 | DISTRIBUTION SYSTEM | |
| | Description/Operation | 1 |
| | General | 1 |
| | Maintenance Practices | 201 |
| | Servicing | 201 |
| | Vacuum Pump Removal/Installation | 201 |
| | Regulator Removal/Installation | 201 |
| | Filter Assembly Removal/Installation | 201 |
| | Adjustment/Test | 203 |
| | Regulator Adjustment | 203 |
| 37-2-1 | INDICATING | |
| | Description/Operation | 1 |
| | General | 1 |
| | Maintenance Practices | 201 |
| | Suction Gauge Removal/Installation | 201 |
| | Suction Gauge Removal | 201 |
| | Suction Gauge Installation | 201 |

VACUUM SYSTEM-DESCRIPTION/OPERATION

1. General (See Figure 1.)

The vacuum system consists of an engine driven vacuum pump, vacuum regulator, filter, directional gyro, horizon gyro and a suction gauge, plus necessary tubing and fittings. Since the vacuum pump is of the dry type, no oil separator is required.

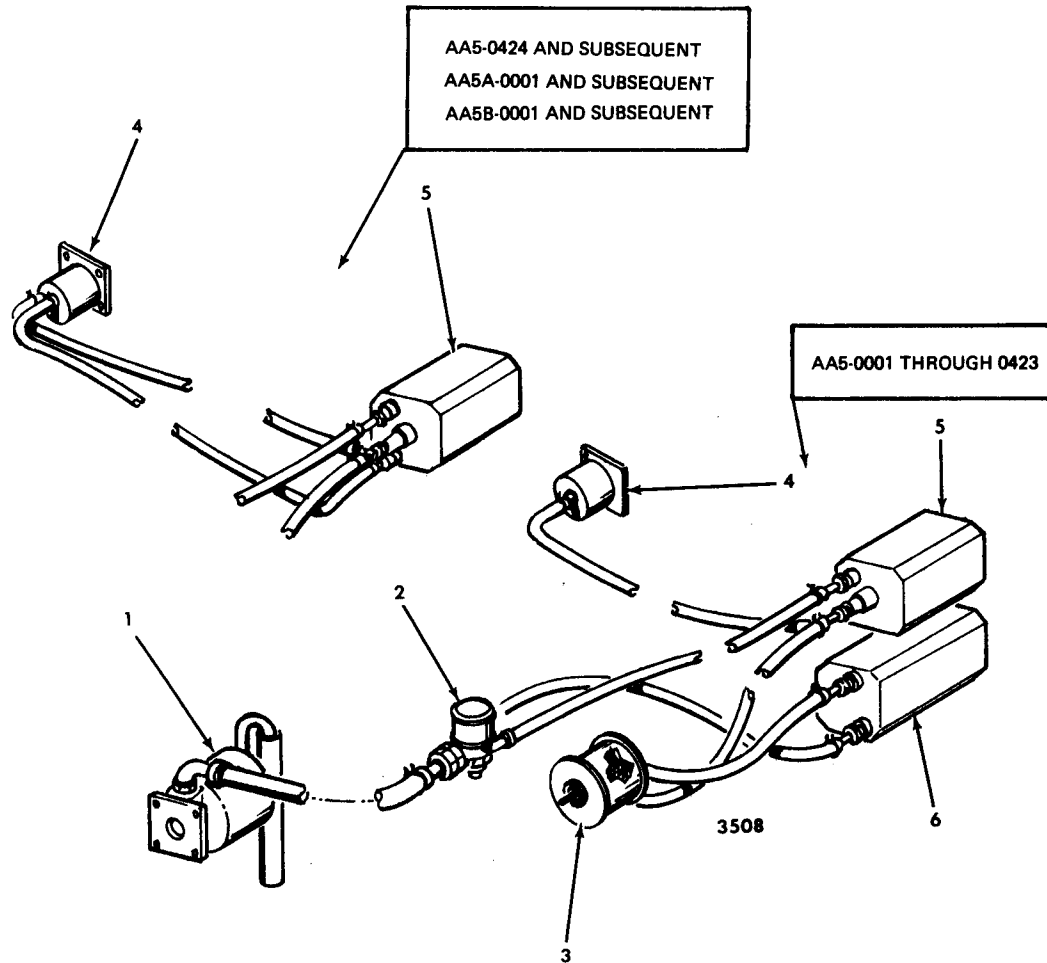

- 1. Engine Driven Vacuum Pump
- 2. Vacuum Regulator
- 3. Vacuum Filter

- 4. Suction Gauge
- 5. Horizon Gyro
- 6. Directional Gyro

Vacuum System
Figure 1

**AA-5 SERIES
MAINTENANCE MANUAL**

VACUUM SYSTEM-TROUBLESHOOTING

1. Vacuum System Troubleshooting

Troubleshoot the vacuum system as follows:

| TROUBLE | PROBABLE CAUSE | REMEDY |
|---|---|--|
| No Vacuum | Pump Inoperative Gauge Inoperative Totally Plugged Central Filter Collapsed Suction Hose | Replace Replace Replace Replace |
| Low Vacuum | Partially Plugged Central Filter Partially Collapsed Suction Hose Improperly Set Regulators | Replace Replace Adjust |
| Erratic Vacuum | Oil in Pump Engine Oil Seal Defective | Replace Replace |
| High Vacuum | Improperly Set Regulators | Adjust |
| Gyro Gauge Follows Engine RPM | Foreign Material on Regulator Seat Regulators Inoperative | Release Tension on regulator, Adjust Screw, Remove Material, Reset. Replace |
| Gauge Reading O. K. Gyros won't Erect | Plugged Filters (Non-Differ- ential Vac. Gauge System) Gyros Inoperative | Replace Filters Replace Gyros |
| Gauge Reading O. K. Gyros Tumble/Precess | Plugged Filters (Non-Differ- ential Vac. Gauge System) Gyro(s) Defective | Replace Filters Replace Gyro(s) |
| Gyro Gauge Indicates Frequent Need for Regulator Adjustment | Central Filters Nearly Plugged (Differential Vac System) | Replace Filters Readjust Regulators |
| Frequent Pump Replacement | Partially Restricted Pump Discharge or Restricted (Kinked) Suction Hose . Incorrect Pump for Engine or System | Replace Hose Check Rotation (Direction) Applications List (Catalog) |
| Pump Oily | Defective Engine Drive Seal | Replace Seal |
| No Vacuum at Low RPM- Vacuum O. K. High RPM | Oil in Pump Suction Hose Cut (Crimped) | Replace Pump Replace Hose |

VACUUM SYSTEM — MAINTENANCE PRACTICES

1. Adjustment/Test

A. Operational Test

NOTE: It is necessary to operate the aircraft engine in order to operationally test the vacuum system.

WARNING: ENSURE THAT PROPELLER AREA IS CLEAR PRIOR TO STARTING ENGINE.

- (1) Start engine in accordance with Pilot's Operating Handbook.
- (2) Set engine speed to 2100 rpm.
- (3) Check that suction gauge indicates between 4.6 and 5.4 inch Hg., and that vacuum-driven gyro instruments (directional gyro and artificial horizon) operate properly.
- (4) Vary engine speed between 2100 and 2400 rpm.
- (5) Check that suction gauge indicates between 4.6 and 5.4 inches Hg. for all power settings.
- (6) Shut down engine in accordance with Pilot's Operating Handbook.

DISTRIBUTION SYSTEM – DESCRIPTION/OPERATION

1. General

The distribution system consists of the engine driven vacuum pump, the vacuum regulator, the vacuum filter, and the lines necessary to route the vacuum to the instruments being driven.

- A. When installing a dry air pump, fitting installation or removal should be accomplished with a few good mechanical practices:
 - (1) Always be sure lines and hoses are clean and free of any debris, oils, or solvents.
 - (2) Replace any hard or brittle hose, particularly on the pump inlet, as sections of the inner layers may come off and will cause a pump failure.
 - (3) If thread compounds are used, always omit the first two lead threads. One recommended compound is spray silicone on the fitting threads.
 - (4) Never over-torque the fittings while installing. Install fittings hand tight, then with a box wrench tighten to desired position a maximum of 1-1/2 turns beyond hand tight.
 - (5) Never place pump directly into a vise. Clamp across the mounting flange with the drive coupling down to remove fittings. Use suitable protection between flange and vise jaws. Never clamp rotor housing in a vise.
- B. When installing a dry air pump, always use a new mounting gasket. Always torque the four pump mounting nuts to 40-50 inch pounds even if it means removing an adjacent appliance. The larger the pump the more important this function becomes. Never use a pump that has been dropped.
- C. Always verify that the pump is the correct one for the engine and/or system. Consult the airframe manufacturer's current parts manual, Airborne Applications List and the PMA label on the pump box. If improper application is suspected or questions arise, check with the dealer's service department.
- D. In the pressure system, always change the inline filter each 500 hours of service, or sooner if environmental conditions are adverse. The inline filters are also to be changed each time that a pump is changed as sharp pieces of carbon rotor or vanes may have been discharged from the previous pump. These particles can cut through the paper filters and cause operational problems with valves, gyros, etc.
- E. Never attempt modifications to systems components. Unauthorized alterations may cause additional problems and void any warranty.
- F. Do not add items in a pneumatic system unless it is an approved change.
- G. Where applicable, Airborne Lo-Loss fittings are recommended for all straight and elbow connections to minimize pressure drop in the system.
- H. Consult service instructions for specific settings or adjustments.

DISTRIBUTION SYSTEM – MAINTENANCE PRACTICES

1. Servicing

A. Regulator Filter

Refer to Chapter 12 for regulator filter servicing.

B. System Filter

Refer to Chapter 12 for system filter servicing.

2. Vacuum Pump Removal/Installation

A. Pump Removal (See Figure 201.)

- (1) Using a clamp removal tool, remove spring clamp from vacuum line at pump.
- (2) Remove vacuum line from pump.
- (3) Remove four nuts and washers securing pump to engine accessory pad.
- (4) Pull pump from engine.
- (5) Cover opening in accessory pad to prevent foreign material from entering engine.

B. Pump Installation

- (1) Inspect pump gasket to ensure that it is clean and undamaged.
- (2) Position pump and gasket on engine accessory pad as shown in Figure 201. Rotate pump slightly so that its splined shaft mates with female spline in engine.
- (3) Slide pump on to its mounting studs on engine accessory pad. Secure pump to engine with four nuts and washers. Torque to 40-50 inch pounds.
- (4) Install line on vacuum pump and secure with hose clamp.

3. Regulator Removal/Installation

A. Regulator Removal (See Figure 202.)

- (1) Using a clamp removal tool, remove spring clamps from three hoses on regulator.
- (2) Remove hoses from regulator.
- (3) While holding regulator to prevent it from turning, use a one inch open end wrench to remove nut securing regulator on firewall.
- (4) Remove regulator from inside aircraft.

B. Regulator Installation

- (1) Position regulator as shown in Figure 202.
- (2) Install nut on firewall side and torque to standard value. Refer to Chapter 91.
- (3) Install three hoses and secure with spring clamps.

4. Filter Assembly Removal/Installation

A. Filter Assembly Removal (See Figure 202.)

- (1) Using a clamp removal tool, remove spring clamps from two hoses on filter assembly.

AA-5 SERIES
MAINTENANCE MANUAL

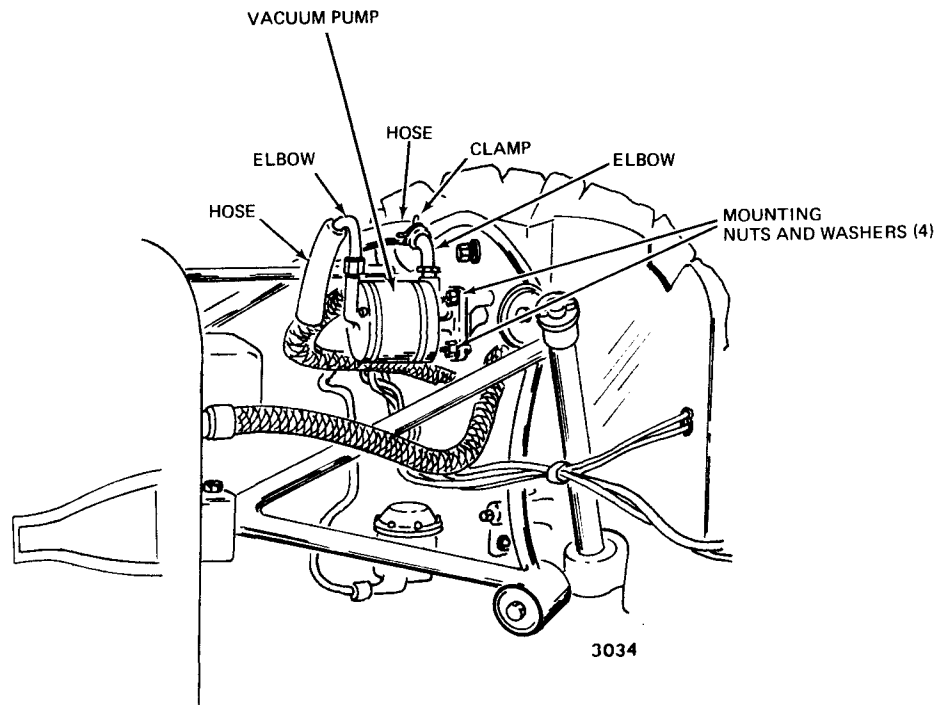

Vacuum Pump Removal/Installation
Figure 201

- (2) Remove hoses from the filter assembly.
- (3) While holding filter to prevent its turning, use a 7/16 inch wrench to remove nut securing filter to firewall.
- (4) Remove filter assembly from inside aircraft.

B. Filter Assembly Installation

- (1) Position filter assembly as shown in Figure 202.
- (2) While holding filter to prevent its turning, install nut and washers on bolt securing it to firewall. Torque nut to standard value. Refer to Chapter 91.
- (3) Install hoses on filter assembly and secure clamps.

5. Adjustment/Test

A. Regulator Adjustment

NOTE: It is necessary to operate the aircraft engine in order to adjust the regulator.

WARNING: ENSURE THAT PROPELLER AREA IS CLEAR PRIOR TO STARTING ENGINE.

- (1) Start engine in accordance with Pilot's Operating Handbook.
- (2) Adjust engine speed to 2200 rpm.
- (3) Adjust regulator adjustment (Figure 202) for an indication of 5.0 inches Hg. on suction gauge.
- (4) Vary engine speed from 2100 rpm to 2400 rpm and ensure that suction gauge indication remains between 4.6 and 5.4 inches Hg. If necessary, readjust regulator adjustment to ensure that proper range of vacuum is obtained.
- (5) Bend locking tabs or safety wire to secure regulator adjustment.
- (6) Shut down engine in accordance with Pilot's Operating Handbook.

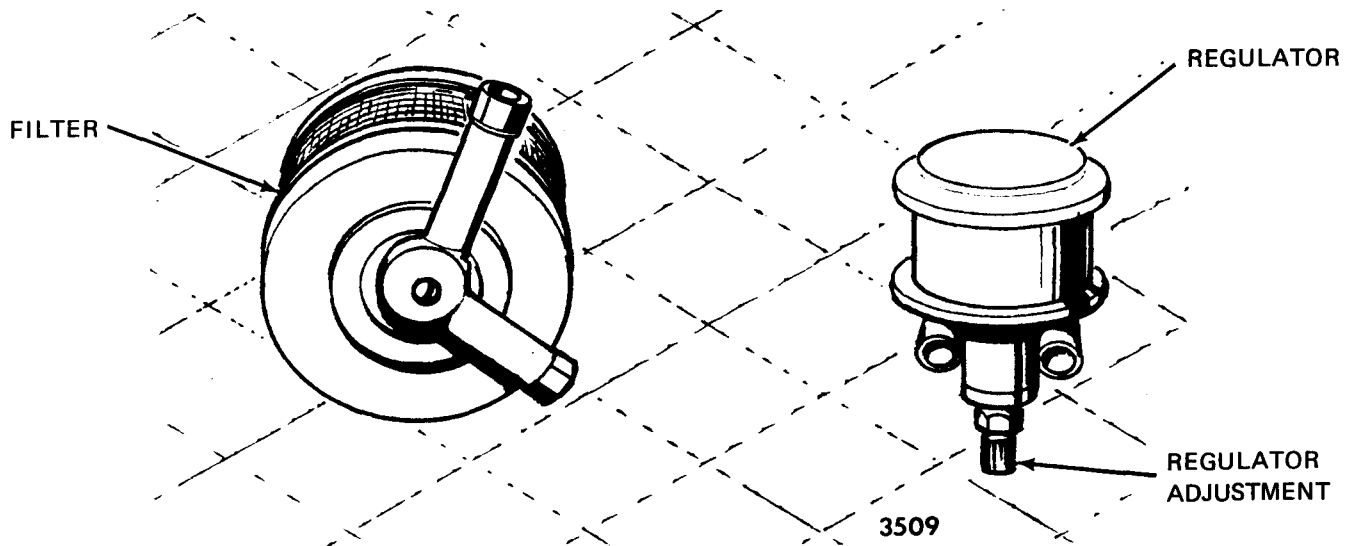

Regulator and Filter Removal and Installation
Figure 202

INDICATING SYSTEM – DESCRIPTION/OPERATION

1. General

The indicating system consists of the suction gauge and the lines attaching it to the other vacuum system components.

INDICATING SYSTEM – MAINTENANCE PRACTICES

1. Suction Gauge Removal/Installation

A. Suction Gauge Removal

- (1) Remove glareshield/deck as described in Chapter 25.
- (2) Using a clamp removal tool, remove spring clamp from vacuum line(s) attached to suction gauge.
- (3) Remove two Phillips screws securing suction gauge.
- (4) Remove suction gauge from aircraft.
- (5) Cap all open lines.

B. Suction Gauge Installation

- (1) Install gauge in instrument panel and secure with two Phillips screws.
- (2) Install hose(s) on rear of suction gauge, and secure with spring clamp(s).
- (3) Reinstall glareshield/deck as described in Chapter 25.

CHAPTER 52

DOORS

TABLE OF CONTENTS

| <u>NUMBER</u> | | <u>PAGE</u> |
|---------------|--|-------------|
| 52-0 | DOORS | |
| | Description/Operation | 1 |
| | General | 1 |
| | Canopy | 1 |
| | Baggage Door | 1 |
| | Assist Handle | 1 |
| 52-1-1 | CANOPY | |
| | Description/Operation | 1 |
| | General | 1 |
| | Maintenance Practices | 201 |
| | Servicing | 201 |
| | Canopy Removal/Installation | 201 |
| | Canopy Latch Removal/Installation | 203 |
| | Window Removal/Installation | 206 |
| | Rear Canopy Seal Removal/Installation | 206 |
| | Canopy Front Seal Removal/Installation | 207 |
| | Adjustment/Test | 207 |
| | Cleaning/Painting | 208 |
| | Painting Metal Surfaces | 208 |
| 52-2-1 | BAGGAGE DOOR | |
| | Description/Operation | 1 |
| | General | 1 |
| | Maintenance Practices | 201 |
| | Servicing | 201 |
| | Baggage Door Removal/Installation | 201 |
| | Cleaning/Painting | 204 |

DOORS – DESCRIPTION/OPERATION

1. General

The doors covered in this chapter consist of a sliding canopy that provides access to the pilot and passenger seats, and a baggage door that provides access to the baggage compartment.

2. Canopy

The canopy is a formed aluminum structure containing side windows of plexiglas, and a latching mechanism to lock the canopy in the closed position.

3. Baggage Door

The baggage door is located on the left side of the fuselage at approximately Fuselage Station 150. It provides access to the baggage compartment.

4. Assist Handle

An assist handle is provided on each side of the fuselage at Fuselage Station 111.00 immediately beneath the canopy rail.

**AA-5 SERIES
MAINTENANCE MANUAL**

CANOPY-DESCRIPTION/OPERATION

1. General

The canopy consists of a formed aluminum structure, mounted on tracks extending along the sides of the fuselage. When positioned in its aft limit of travel the canopy opening provides an entry opening approximately 34 to 40 inches in area. This allows entry into both front and rear seats of the airplane. Fixed windows on each side of the canopy provide lateral visibility. The canopy is held in the closed (forward) position by a latch mechanism that can be actuated by handles from either inside or outside the airplane. A key actuated lock is provided to lock the canopy from outside the airplane.

CANOPY – MAINTENANCE PRACTICES

1. Servicing

A. Rail Lubrication

WARNING: USE SOLVENTS IN A WELL VENTILATED AREA. AVOID BREATHING FUMES. KEEP AWAY FROM FLAMES.

- (1) Use isopropyl alcohol and a small brush to clean the teflon runners inside the canopy outer tracks. Ensure that the tracks are clean and free of residue.
- (2) Inject a small amount of non oil base spray lubricant (E-Z-Free by XIM Products, Inc., 1169 Bassett Road, Westlake, Ohio 44145, or equivalent) into the sliding surfaces.
- (3) Open and close the canopy several times to distribute the lubricant.

B. Latch Lubrication

Lubricate latch in accordance with Chapter 12.

2. Canopy Removal/Installation

A. Canopy Removal (See Figure 201.)

- (1) Remove bottom row of Phillips screws (1) on each side of canopy.
- (2) Lift canopy straight up and remove from aircraft.

B. Canopy Installation (See Figure 201.)

- (1) If the original canopy is being reinstalled, proceed as follows:
 - (a) Lower canopy straight down and align holes in canopy with holes in rails.
 - (b) Install bottom row of Phillips screws (1) through canopy into track.
- (2) If new canopy is being installed proceed as follows:

On aircraft serial AA5-0230 and subsequent, AA-5A and AA-5B canopy, attach holes are jig drilled prior to canopy installation on the aircraft. Aircraft prior to this serial number have canopy attach holes located during canopy installation. Replacement canopies supplies for these aircraft will not have attach holes drilled, nor will the lower edge be trimmed to size. The following is provided to assist the mechanic making the installation.

- (a) Remove existing canopy and hardware that is to be replaced. This canopy may be used as necessary to determine hole size and approximate locations during installation of the replacement canopy.
- (b) Preliminary Fit: With inner track assemblies located in the closed position, temporarily locate canopy on aircraft. Line up canopy outer forward skin with windshield contour and "C" clamp forward canopy bow to windshield bow. Tighten or loosen clamps as necessary to obtain 1/8 inch clearance in both upper corners between the aft canopy bow and the turtle-back skin. The clearance along the area below the corners should be equal on both sides.

NOTE: Forward and aft canopy bow lower ends may bottom out on the outer track assemblies attached to the fuselage. File as necessary to achieve the above fit. Remove canopy from aircraft.

AA-5 SERIES
MAINTENANCE MANUAL

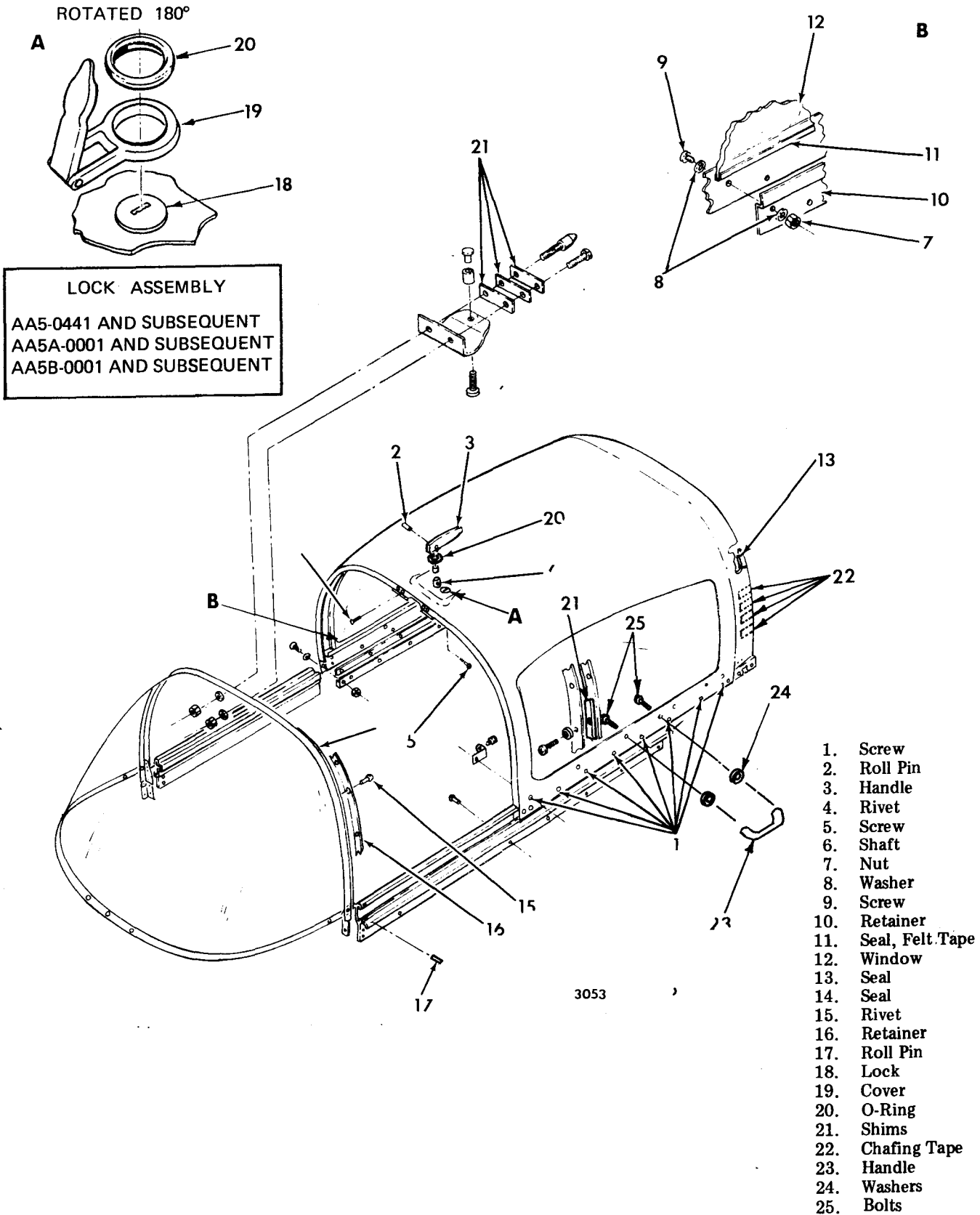

3053

**AA-5 SERIES
MAINTENANCE MANUAL**

- (c) Final Fit: Temporarily attach window retainers to the inner tracks and locate tracks in closed position on the aircraft. Place canopy over tracks and locate as stated in Step (b).
- (d) Mark lower canopy skin and bow ends for final trimming. The trim line should correspond to the lower edge of the retainers.
- (e) From inside cabin, back drill 10 (five each side), holes through the canopy skin, using the upper holes in the retainers for locations.

NOTE: Hold canopy skin flat to avoid wrinkles while back drilling.

- (f) Remove canopy from aircraft and trim lower edges per lines established in Step (d).
- (g) Attach retainers to the canopy using holes drilled in Step (e). Locate and drill remaining 16 (eight each side), lower attach holes using the retainers for hole location.
- (h) Install canopy on aircraft. Install additional hardware items and interior to complete the installation.

NOTE: To obtain a right seal between the windshield and canopy bows, the windshield may be loosened and slightly shifted. The ideal condition is achieved when the gap (canopy not in locked position), between the bows is slightly greater at the top.

3. Canopy Latch Removal/Installation

A. Canopy Latch Removal (See Figure 201.)

- (1) Remove roll pin (2) from exterior door handle (3).
- (2) Remove latch cover and center canopy trim panel. Refer to Chapter 25.
- (3) Use a small drift punch to drive out the mandrel in the center of the rivets (4).
- (4) Use a number 30 drill (0.1285 inch diameter) to drill out the rivets (4).
- (5) Remove the screws (5) securing latch to canopy.
- (6) Remove latch from canopy.

B. Latch Disassembly (See Figure 202.)

- (1) Disconnect spring (1) from cotter pin (2).
- (2) Use a 3/8 inch wrench and Phillips screwdriver to remove nuts (3) and washers (4 and 5) from screws (6).
- (3) Remove link (7) from screws (6).
- (4) Remove spacers (8) and washers (9) from screws (6).
- (5) Remove guide (10) and screws (6) from housing (11).
- (6) Disconnect spring (12) from cotter pin (2).
- (7) Remove screw (13) washer (14) and nyliner (15) from housing (11).
- (8) Lift lever assembly (16) from housing and remove washers (17) from lever assembly shaft.
- (9) Use a 3/8 inch wrench and Phillips screwdriver to remove nut (18) from screw (19).

**AA-5 SERIES
MAINTENANCE MANUAL**

- (10) Remove washers (20), spacer (21), and lever assembly (16) from screw (19).
- (11) Remove screw (19) from hook (22).
- (12) Remove nut (23) from screw (24).
- (13) Remove washer (25). Then remove spacer (26), spring (12), and washer (27) from screw (24).
- (14) Remove screw (24) from hook (22).
- (15) Press rivet (28) from lever assembly (16).
- (16) Remove screws (29), then remove handle (30) from lever assembly (16).

C. Latch Assembly (See Figure 202.)

- (1) Position handle (30) on lever assembly (16) and secure with screws (29).
- (2) Press rivet (28) into lever assembly (16).
- (3) Insert screw (24) into hook (22) and install washer (27) and spacer (26) on screw (24).
- (4) Place end of spring (12) over spacer (26). Install washer (25) and secure with nut (23). Tighten nut to standard torque value, per Chapter 91.
- (5) Install screw (19) in hook (22).
- (6) Install washer (20) and spacer (21) on screw (19).
- (7) Place lever assembly (16) over spacer (21) and install washer (20) and nut (18), tighten nut.
- (8) Place washers (17) over hole in housing (11) and slide bottom shaft of lever assembly (16) through washers (17) and housing (11).
- (9) Install nyliner (15) washer (14) and screw (13), tighten screw.
- (10) Connect spring (12) to cotter pin (2).
- (11) Position guide (10) on housing (11) and install screws (6).
- (12) Place washers (9) and spacers (8) on screws (6).
- (13) Install link (7) on spacers (8).
- (14) Install washers (4 and 5) and nuts (3) on screws (6), tighten nuts.
- (15) Connect spring (1) to cotter pin (2).
- (16) Lubricate moving parts of latch with a light film of lubriplate $\frac{1}{2}$ 501, or equivalent.

D. Latch Installation (See Figure 201.)

- (1) Position latch assembly in canopy with shaft of lever assembly (6) extending through the door handle opening, and the guide end of the latch assembly facing forward.
- (2) Secure the aft end of the latch assembly to the canopy by installing the screws (5).
- (3) Secure the forward end of the latch assembly to the canopy with Avex rivets (4) (Part No. 1604-0412).

**AA-5 SERIES
MAINTENANCE MANUAL**

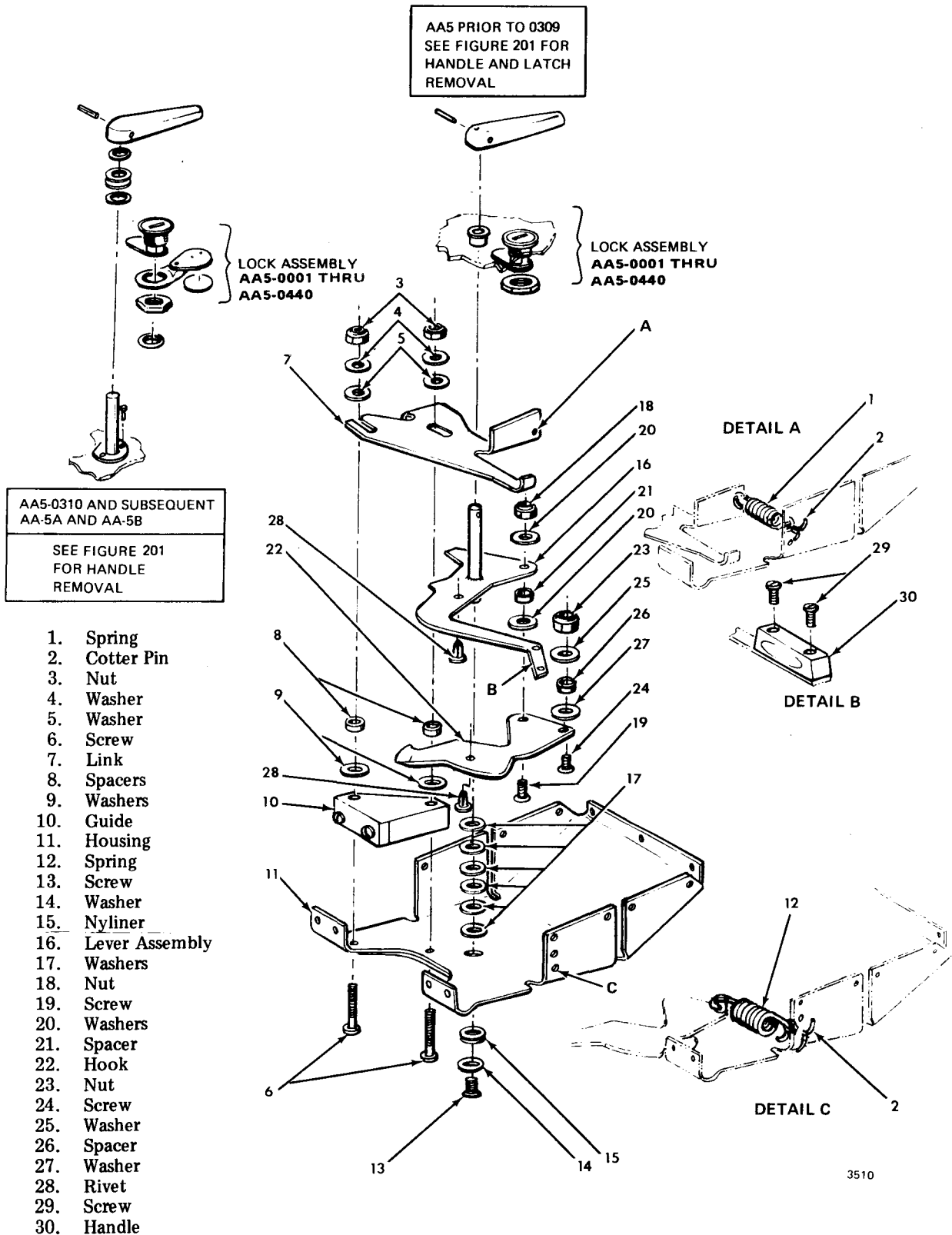

Canopy Latch Disassembly/Assembly (Sheet 1 of 2)
Figure 202

AA-5 SERIES
MAINTENANCE MANUAL

- (4) Install handle (3) and O-ring (3) on shaft of lever (6) and secure with roll pin (2).

NOTE: The canopy latch assembly can be adjusted for a tighter seal between the canopy and windshield by installing additional shims (Figure 201), as required.

NOTE: It is necessary to remove the canopy latch from the canopy in order to remove the key lock assembly.

4. Window Removal/Installation

A. Window Removal (See Figure 201.)

- (1) Remove canopy inner trim, as applicable. Refer to Chapter 25.
- (2) Remove nuts (7), washers (8), screws (9), and retainers (10) securing glass to canopy.
- (3) Remove glass.

B. Window Installation (See Figure 201.)

CAUTION: NEVER USE GASOLINE, BENZINE, ALCOHOL, ACETONE, CARBON TETRACHLORIDE, FIRE EXTINGUISHER FLUID, ANTI-ICE FLUID, LACQUER THINNER OR GLASS CLEANER TO CLEAN PLASTIC. THESE MATERIALS WILL DAMAGE THE PLASTIC AND MAY CAUSE SEVERE CRAZING.

WARNING: USE SOLVENTS IN A WELL VENTILATED AREA. AVOID BREATHING FUMES. KEEP AWAY FROM FLAMES.

- (1) Use Stoddard solvent or equivalent to clean all foreign material from the window in an area approximately one inch wide around the edge of the window.
- (2) Install seal felt tape (11) (Part No. 7402) around edge of window.
- (3) Position window (12) in canopy and secure with retainers (10), screws (9), washers (8) and nuts (7).
- (4) Seal area between window (11) and canopy with Presstite Sealer, or equivalent.
- (5) Reinstall canopy inner trim. Refer to Chapter 25.

5. Rear Canopy Seal Removal/Installation (See Figure 201.)

WARNING: USE SOLVENTS IN A WELL VENTILATED AREA. AVOID BREATHING FUMES. KEEP AWAY FROM FLAMES.

A. Rear Canopy Seal Removal

NOTE: Methyl Ethyl Ketone (MEK) will attack the paint on the surfaces to which the seal is cemented. After removal of the seal, it will be necessary to repaint this area prior to installation of a new seal.

- (1) Use a cloth moistened with Methyl Ethyl Ketone to soften the cement holding the seal (13) to the canopy.
- (2) Use a fiber scraper to lift the seal as the cement softens and slowly peel from canopy.
- (3) Use the moistened cloth to remove remaining cement from canopy.

B. Rear Canopy Seal Installation

- (1) Clean and repaint area of seal on canopy. Refer to Chapter 20. Allow paint to dry thoroughly prior to installing a new seal.

- (2) Cement new seal (Part No. 1803-4) to canopy with A851-B adhesive, B. F. Goodrich Inc., (or equivalent).

6. Canopy Front Seal Removal/Installation (See Figure 201.)

A. Canopy Front Seal Removal

- (1) On early Model AA-5 aircraft, use a number 30 drill to drill out the rivets (15), thereby releasing the retainer (16) and seal (14). Late Model AA-5 and AA-5B aircraft utilize screws and nuts to attach the retainer.

B. Canopy Front Seal Installation

- (1) Install a new seal (14) retainer (16) and secure. Use new rivets (15) part number MS20470AD4-6 on early Model AA-5 aircraft.

NOTE: If holes are enlarged or deformed as a result of drilling out rivets, use a number 21 drill and enlarge the holes to 0.159 inch diameter, and install new rivets, part number MS20470AD5-6.

- (2) Adjust canopy latch as required for proper seal.

7. Adjustment/Test

A. Track Adjustment

Field experience has shown that after extended operation, the canopy may become difficult to open and close. The following suggestions are provided to aid in maintaining satisfactory freedom of operation of the canopy.

- (1) DO NOT use the canopy as a hand hold during entry to and exit from the aircraft as bending of the inner tracks can result.
- (2) The inner canopy tracks must be perfectly straight. If the tracks are bent, they should be straightened or replaced.
- (3) The sliding surfaces of the canopy inner tracks and the teflon runners in the canopy outer tracks must be kept clean and lightly lubricated. Smoother operation may be achieved by cleaning the sliding surfaces with isopropyl alcohol and a small brush and then injecting a small amount of spray lubricant into the sliding surfaces. Production aircraft canopy tracks are lubricated with E-Z Free lubricant which is available in 6 or 16 ounce spray cans from the Customer Service Department or from XIM Products, Inc. 1169 Bassett Road, Westlake, Ohio 44145.
- (4) If external cleaning and lubricating does not satisfactorily eliminate canopy sticking or binding, the canopy should be removed from the tracks and the tracks slid completely out of the aircraft. All sliding surfaces should then be carefully cleaned with isopropyl alcohol and relubricated with a very thin film of lubricant. If the teflon runners are galled or severely worn, they should be replaced. The teflon runners are secured in the outer tracks with roll pins (Item 17, Figure 201), Esna part number 52-012-062-0500, inserted at the forward end of each channel.
- (5) A canopy track sizing tool part no. ST-1064 is available which may be used to resize the teflon runners when the tracks are removed for cleaning or when the teflon runners are replaced in the field. This tool is simply inserted into the outer track in place of the sliding inner track and forced through the entire length of the outer track to force the teflon runners tightly into the retaining channels. Properly installed teflon runners allow a 1/32 inch to 1/16 inch vertical clearance between the inner canopy track and the runners. This clearance can be checked with the canopy installed by moving it up and down and measuring the inner track movement. Clean lubricated teflon runners installed with the correct clearance are essential for smooth, free canopy operation.

**AA-5 SERIES
MAINTENANCE MANUAL**

8. Cleaning/Painting

A. Plexiglas Cleaning

CAUTION: NEVER USE GASOLINE, BENZINE, ALCOHOL, ACETONE, CARBON TETRACHLORIDE, FIRE EXTINGUISHER FLUID, ANTI-ICE FLUID, LACQUER THINNER OR GLASS CLEANER TO CLEAN PLASTIC. THESE MATERIALS WILL DAMAGE THE PLASTIC AND MAY CAUSE SEVERE CRAZING.

- (1) If large deposits of mud and/or dirt have accumulated on the plexiglas, flush with clean water. Rubbing with your hand is recommended to dislodge excess dirt and mud without scratching the plexiglas.
- (2) Wash with soap and water. Use a sponge or heavy wadding of a soft cloth. DO NOT rub, as the abrasive action in the dirt and mud residue will cause fine scratches in the surface.
- (3) Grease and oil spots may be removed with a soft cloth soaked in kerosene.
- (4) After cleaning, wax the plexiglas surface with a thin coat of hard polish-wax. Buff with a soft cloth.
- (5) If a severe scratch or marring occurs, jeweler's rouge is recommended. Follow directions, rub out scratch, smooth, apply wax, and buff.

B. Painting Metal Surfaces

Refer to Chapter 20 for metal cleaning and painting procedures.

BAGGAGE DOOR-DESCRIPTION/OPERATION

1. General

The baggage doors installed on aircraft AA5-0406, and subsequent, AA-5A, and AA-5B aircraft and are located on the left side of the fuselage at approximately fuselage Station 150. This hinge-mounted door provides an opening measuring approximately 24 by 12 inches for access to the baggage compartment. The door is hinged on its forward end and provided with a chain type restraint to prevent damage to hinges due to over-travel. Door opening from outside the aircraft is accomplished by actuating the latch mounted at the rear of the key-actuated lock mounted on the door. The door can be opened from inside the aircraft by actuating a slide-type latch.

BAGGAGE DOOR — MAINTENANCE PRACTICES

1. Servicing

A. Hinge Lubrication

Refer to Chapter 12 for hinge lubrication procedures.

B. Latch Lubrication

Refer to Chapter 12 for latch lubrication procedures.

2. Baggage Door Removal/Installation

A. Baggage Door Removal (See Figure 201.)

- (1) Remove interior trim surrounding baggage door. Refer to Chapter 25.
- (2) Use a number 30 drill to remove the eight rivets (1) securing the baggage door to the aircraft.
- (3) Remove cotter pin (2), washer (3), and clevis (4) from aircraft.
- (4) Open baggage door latch (5) and remove baggage door from the aircraft.

B. Latch Disassembly (See Figure 204.)

- (1) Remove trim panel from inside of door. Refer to Chapter 25.
- (2) Disconnect spring (1) from cotter pin (2) and clip (3).
- (3) Remove cotter pin (4), washer (5) and clevis pin (6).
- (4) Remove cotter pin (2), washer (7) and clevis pin (8), then remove link (9).
- (5) Remove bolt (10) and washer (11), then pull slide (12) from under clip (3). Remove washer (13).
- (6) Remove screw (14), lockwasher (15) and link (16) from camlock (17).
- (7) Unscrew camlock retainer nut (18) and remove camlock (17).

NOTE: If clip (3) is to be removed, it is necessary to drill out the rivets (19) retaining it. Replacement will require use of blind fasteners.

- (8) Remove clip (3) by drilling rivets (19) out with a number 30 drill.

C. Latch Assembly (See Figure 204.)

- (1) Place camlock (17) in door so that key slot will be vertical when door is installed. Secure with retainer nut (18).
- (2) If clip (3) has been removed, position clip (3) over mounting holes and secure with two blind rivet fasteners.
- (3) Place clevis pin (8) through matching holes in slide (12) and link (9). Secure with washer (7) and cotter pin (2).
- (4) Place clevis pin (6) through matching holes in link (16) and link (9). Secure with washer (5) and cotter pin (4).

AA-5 SERIES
MAINTENANCE MANUAL

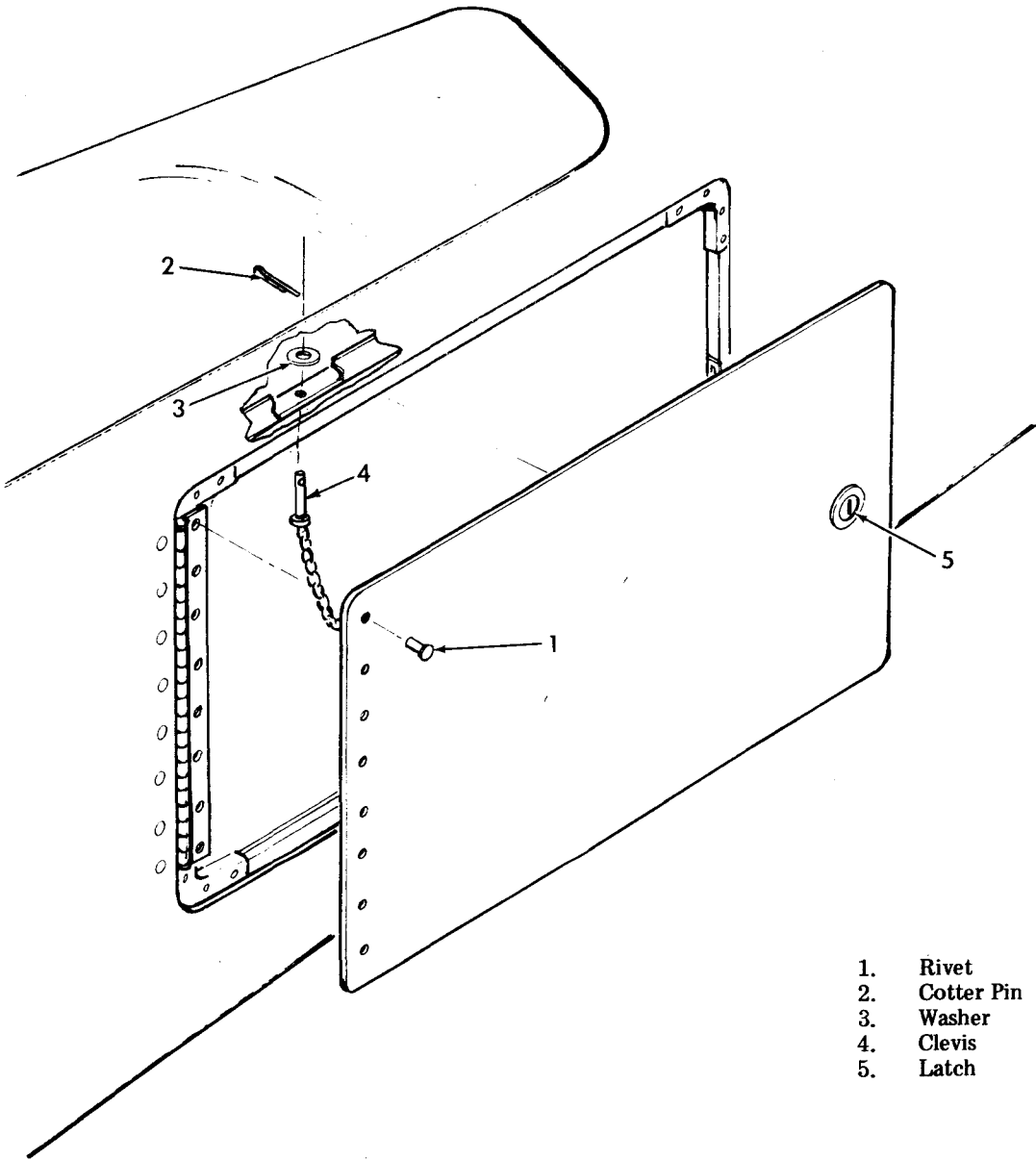

1. Rivet
2. Cotter Pin
3. Washer
4. Clevis
5. Latch

Baggage Door — Removal/Installation
Figure 203

AA-5 SERIES
MAINTENANCE MANUAL

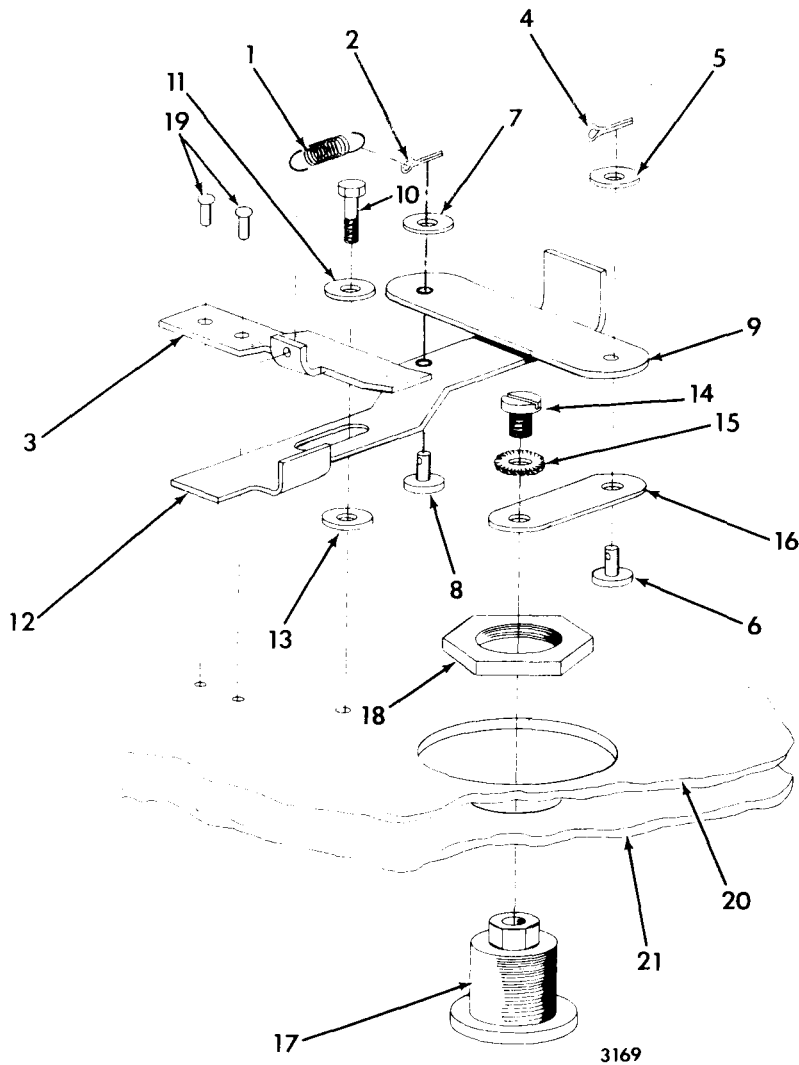

1. Spring
2. Cotter Pin
3. Clip
4. Cotter Pin
5. Washer
6. Clevis Pin
7. Washer
8. Clevis Pin
9. Link
10. Bolt
11. Washer
12. Slide
13. Washer
14. Screw
15. Lockwashers
16. Link
17. Camlock
18. Retainer Nut
19. Rivets
20. Pan
21. Door Skin

Baggage Door Latch Disassembly/Assembly
Figure 204

AA-5 SERIES
MAINTENANCE MANUAL

- (5) Place washer (13) over bolt hole in pan.
- (6) Place slide (12) over washer (13) so that their holes are aligned with bolt hole and so that slide (12) is under clip (3).
- (7) Install washer (11) and bolt (10) and torque bolt to allow 0.032 inch end play for slide.
- (8) Install spring (1) on cotter pin head (2) and clip (3).
- (9) Position link (16) so that it is parallel with slide (12), and hold in position while securing with washer (15) and screw (14).

D. Door Installation (See Figure 205.)

NOTE: If the door is being reinstalled, omit Step (3).

- (1) Position door so that its hinge fits between fuselage skin and the baggage door facing.
- (2) Adjust door so that it fits within door facing with a clearance of 0.06 inch between the door and the aircraft skin.
- (3) While holding the door in this position, drill 0.098 inch holes in hinge to match holes in skin and facing.
- (4) Secure door to aircraft with eight MS24026AD3-3 rivets.
- (5) Install clevis (4, Figure 203) washer (3) and cotter pin (2).
- (6) Install interior trim. Refer to Chapter 25.

3. Cleaning/Painting

Refer to Chapter 20 for metal cleaning and painting procedures.

AA-5 SERIES
MAINTENANCE MANUAL

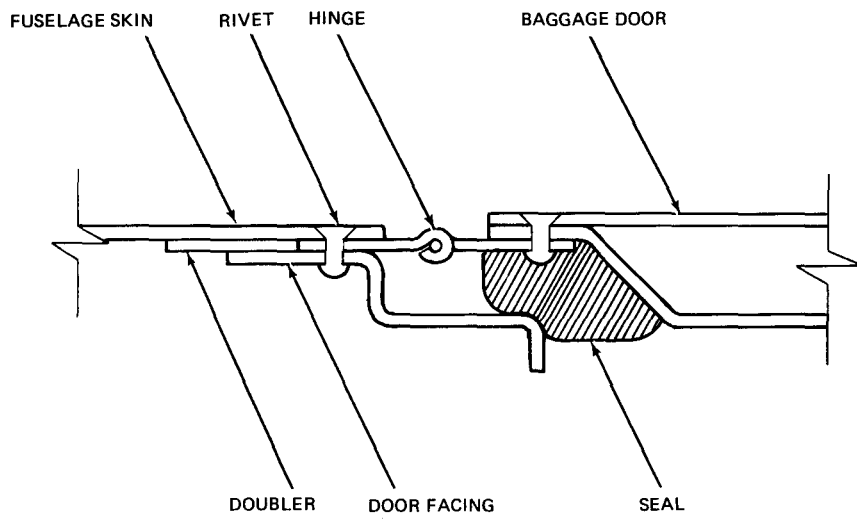

3170

Baggage Door Installation
Figure 205

AA-5 SERIES
MAINTENANCE MANUAL

CHAPTER 53

FUSELAGE

TABLE OF CONTENTS

| <u>NUMBER</u> | | <u>PAGE</u> |
|---------------|--|-------------|
| 53-0 | FUSELAGE | |
| | Description/Operation | 1 |
| | General | 1 |
| | Fuselage Assembly Components | 1 |
| | Maintenance Practices | 201 |
| | Removal/Installation of Inboard Spar | 201 |
| | Removal/Installation of Dorsal Fin (AA5-0001 thru 0405) | 201 |
| | Removal/Installation of Dorsal Fin (AA5-0406 and Subsequent, AA-5A and AA-5B) | 202 |
| | Removal/Installation of Fillet (AA-5) | 204 |
| | Removal/Installation of Horizontal Stabilizer Fairing (AA-5A and AA-5B) | 204 |
| | Removal/Installation of Tailcone | 204 |
| | Removal/Installation of Ventral Fin | 204 |
| | Removal/Installation of Access Covers on Aft Fuselage | 204 |
| | Removal/Installation of Brackets, Supports, and Attach Fittings | 207 |

FUSELAGE -- DESCRIPTION/OPERATION

1. General

The main fuselage structure (Figure 1) is a one piece bonded aluminum assembly using one-half inch thick lightweight aluminum honeycomb panels to form the cabin area. The aft section of the fuselage from the cabin area rearward is composed of sheet aluminum panels bonded together with high strength adhesive and formed to aluminum stiffeners and bulkheads. Bulkheads inside the cabin compartment provide support for the floor panels and attaching provisions for other equipment. The engine support mounts and support mount doublers are bonded to the front end of the main fuselage structure.

Most fuselage maintenance requirements will consist of removal and replacement of detachable components or structural repair as detailed in Chapter 20.

2. Fuselage Assembly Components

The fuselage assembly consists of the main fuselage structure, the inboard carry through spar, ventral fin (AA-5), dorsal fin, horizontal stabilizer fairing, horizontal stabilizer fillet, tailcone, aft fuselage access covers, and attach fittings and brackets for other equipment. These items are detachable and may be removed and replaced when necessary. The tubular inboard carry through spar extends through the main fuselage structure beneath the pilot and copilot's seats, and provides attach points for the wings and the main landing gear. The spar is attached to the fuselage structure with four support attach brackets. Two brackets are located above the spar on the inside of the fuselage and two are located beneath the spar on the outside of the fuselage structure. The removable attach fittings, fairings, fins, fillets, tailcone, and access covers are secured to the fuselage with screws.

The tailcone is made of thermo-plastic and consists of an upper and a lower half. Either half can be removed separately. The tail light is mounted in the rearmost part of the tailcone. The tailcone houses the rudder and elevator bellcrank assemblies.

The horizontal stabilizer fairing on the AA-5A and AA-5B aircraft and the dorsal fin on aircraft AA5-0406 and subsequent, AA-5A and AA-5B are made of thermo-plastic. They are attached to the main fuselage structure with screws and clips. The horizontal stabilizer fillets on AA-5 aircraft and the dorsal fin on AA5-0001 through 0405 are made of sheet aluminum and attached to the fuselage structure with screws.

The access covers on the aft section of the fuselage on all models are made of aluminum and attached with screws. The ventral fin is made of 1/2 inch lightweight aluminum honeycomb, and is installed on AA-5 aircraft only.

AA-5 SERIES
MAINTENANCE MANUAL

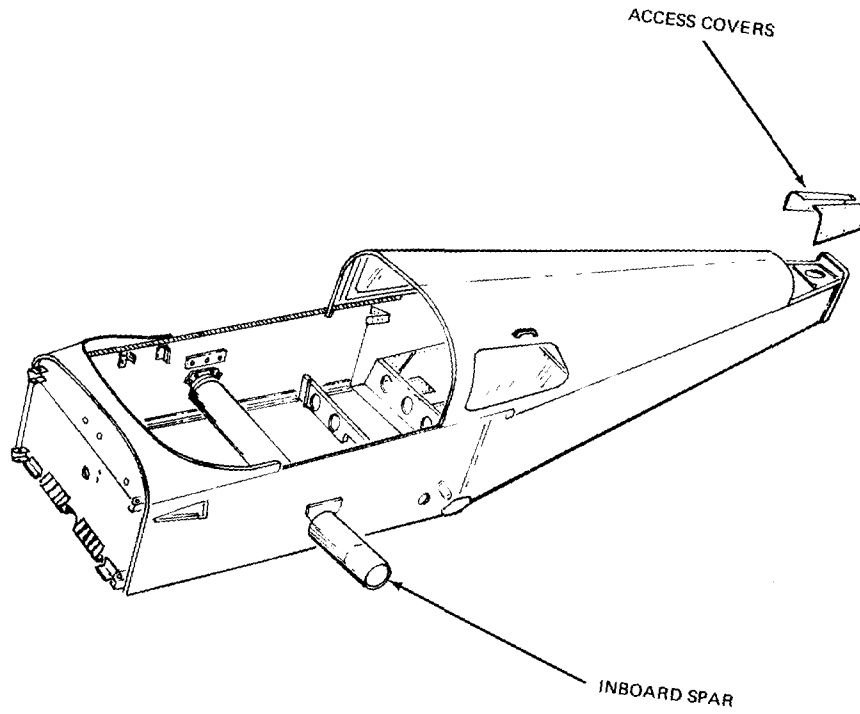

3283

Fuselage Assembly - AA-5 Serial No. 0001 Thru 0405
Figure 1 (Sheet 1 of 2)

AA-5 SERIES
MAINTENANCE MANUAL

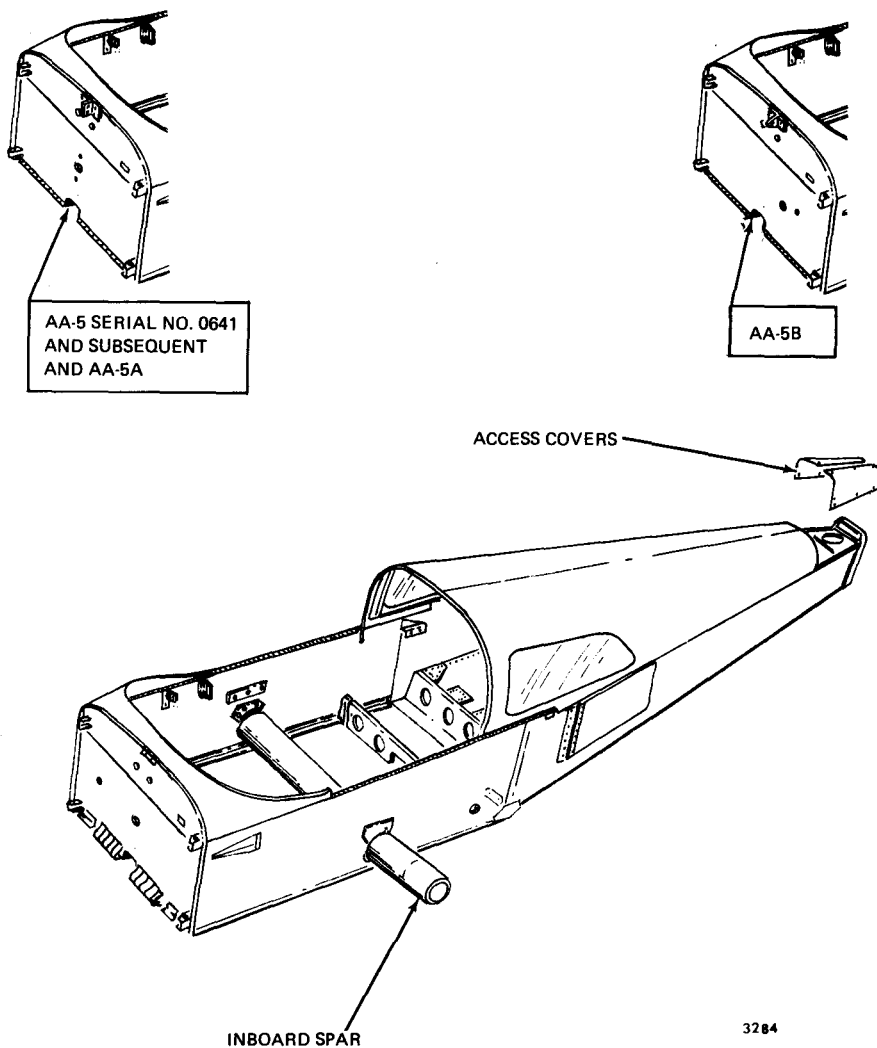

Fuselage Assembly - AA-5 Serial No. 0406 and Subsequent, AA-5A and AA-5B
Figure 1 (Sheet 2 of 2)

FUSELAGE — MAINTENANCE PRACTICES

1. Removal/Installation of Inboard Spar

A. Remove Inboard Spar (See Figure 201.)

- (1) Remove wings and wing roots. (Refer to Chapter 57.)
- (2) Remove main landing gear. (Refer to Chapter 32.)
- (3) Remove seats and upholstery as necessary to gain access to support brackets. (Refer to Chapter 25.)
- (4) Remove trim console attach screw and rear seat support brackets from inboard spar.
- (5) Remove sealant from around spar at fuselage structure.
- (6) Remove bolts that attach support brackets to spar on outside of fuselage structure.
- (7) Remove bolts that attach support brackets to spar and that attach support brackets to fuselage, on inside of fuselage structure and remove support brackets.
- (8) Slide inboard spar out of main fuselage structure.

B. Install Inboard Spar

- (1) Slide inboard spar through main fuselage structure and line up bolt holes with bolt holes in lower support brackets.
- (2) Install bolts, washers, and nuts that attach lower support brackets to inboard spar but do not tighten nuts.
- (3) Position upper support brackets in place and secure to fuselage structure with bolts, screws, washers, and nuts. Torque nuts to 60-70 inch pounds.
- (4) Align holes in spar with holes in support bracket and install shims as required, bolts, washers and nuts. Torque all spar attaching bolts to 340-360 inch pounds.
- (5) Apply Presstite soft putty sealant around spar on outside of fuselage structure.
- (6) Install rear seat support brackets and connect trim console to inboard spar.
- (7) Install seats and upholstery removed at spar removal. (Refer to Chapter 25.)
- (8) Install main landing gear. (Refer to Chapter 32.)
- (9) Install wing roots and wings. (Refer to Chapter 57.)

2. Removal/Installation of Dorsal Fin — AA5 Serial No. 0001 through 405 (See Figure 202.)

A. Remove Dorsal Fin

- (1) Remove screws securing fin to vertical stabilizer.
- (2) Punch out mandrel in center of rivets with a small drift punch, then drill out rivets with a No. 30 drill.
- (3) Remove dorsal fin.

AA-5 SERIES
MAINTENANCE MANUAL

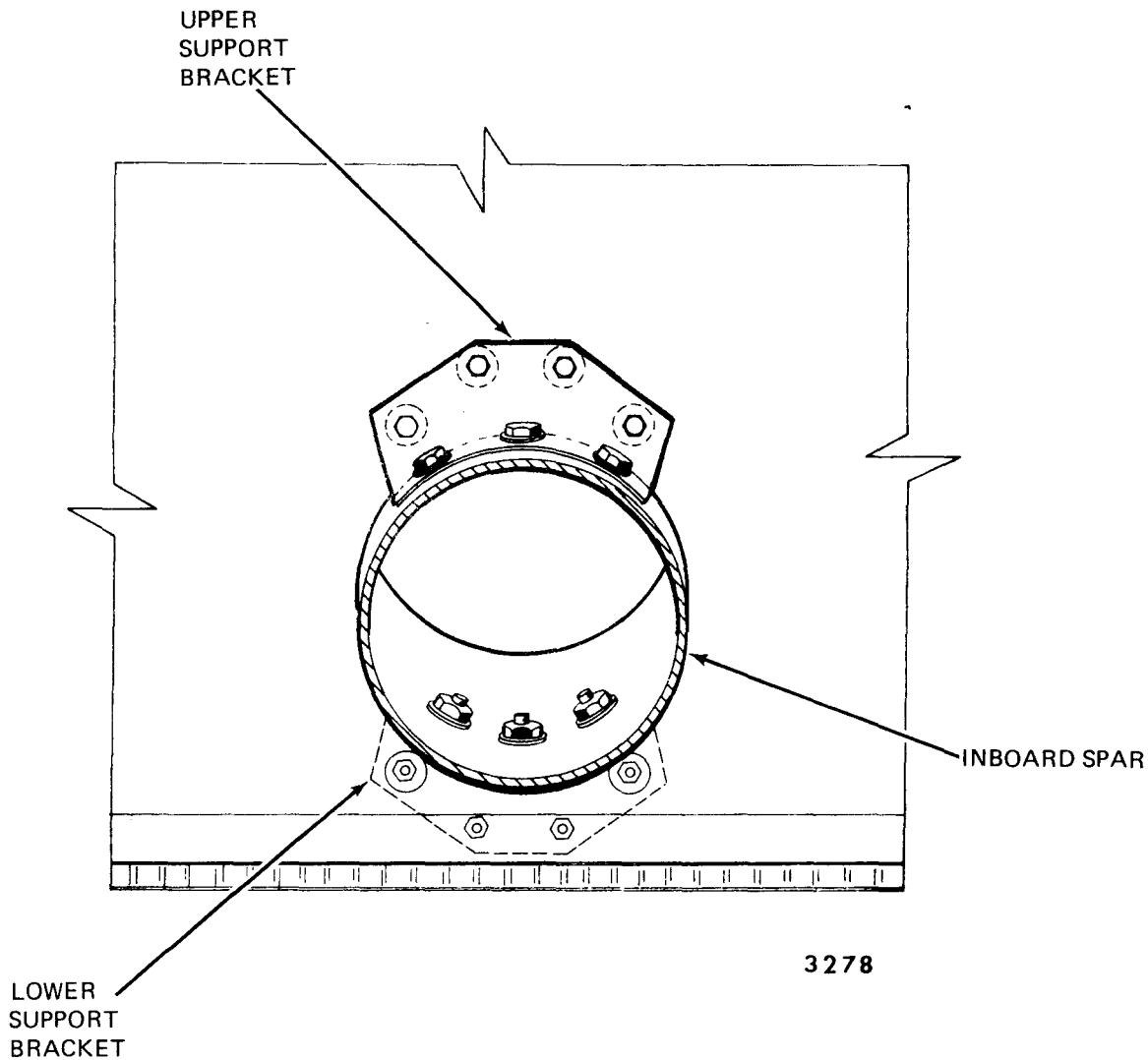

Inboard Spar Installation — Inside View
Figure 201

- B. Install Dorsal Fin
 - (1) Position dorsal fin in place using a new seal at mating surface.
 - (2) Install attaching screws and rivets.
3. Removal/Installation of Dorsal Fin — AA-5 Serial No. 0406 and Subsequent, AA-5A, and AA-5B (See Figure 202.)
 - A. Remove Dorsal Fin
 - (1) Remove screws and washers that attach dorsal fin to vertical stabilizer.
 - (2) Slide fin forward to release channel base from clips and remove fin.
 - B. Install Dorsal Fin
 - (1) Position fin in place on fuselage and slide back to engage channel base with clips.
 - (2) Install screws and washers that attach fin to vertical stabilizer.

AA-5 SERIES
MAINTENANCE MANUAL

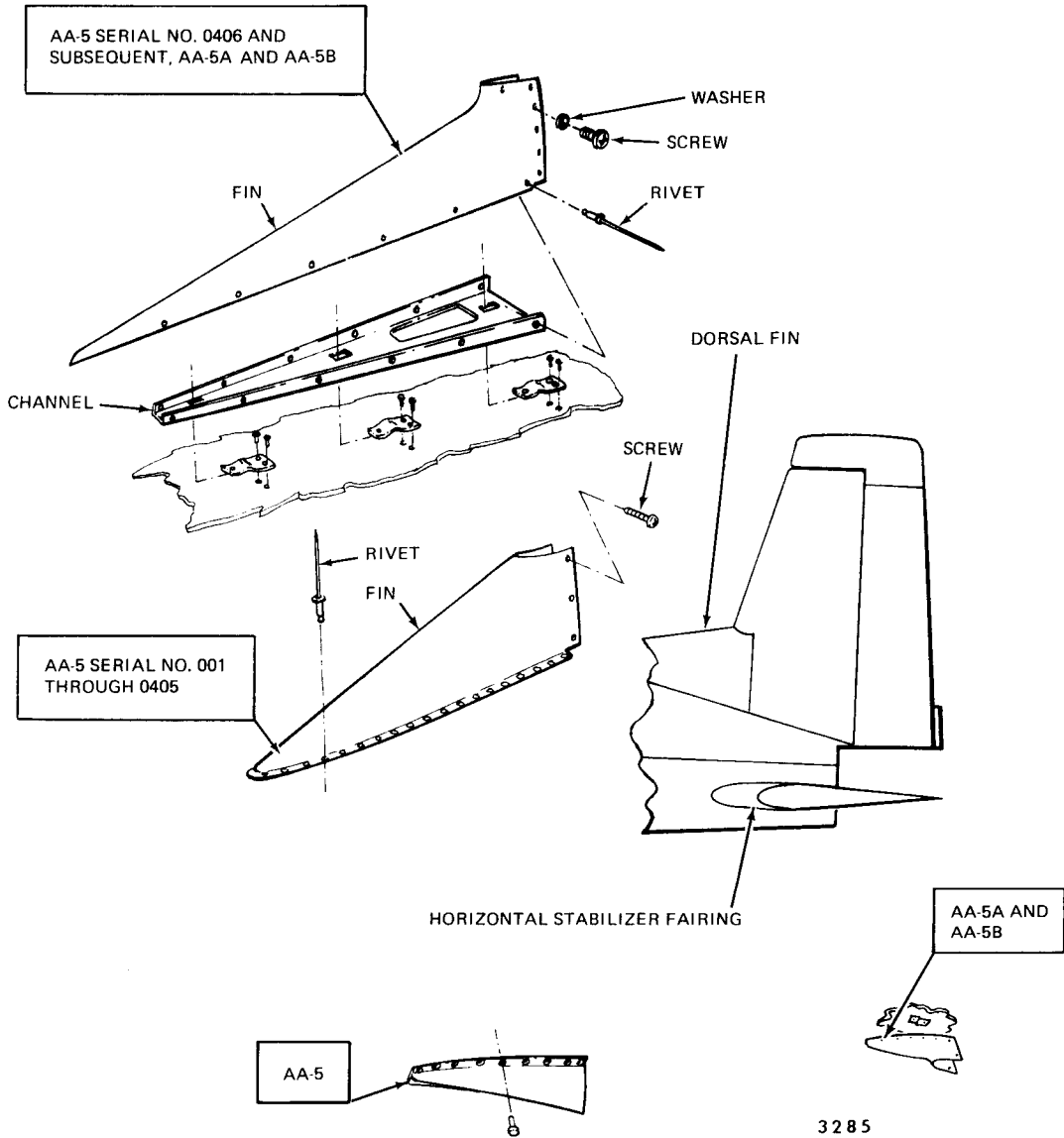

3285

Dorsal Fin and Horizontal Stabilizer Fairings
Figure 202

**AA-5 SERIES
MAINTENANCE MANUAL**

4. Removal/Installation of Horizontal Stabilizer Fillet — Model AA-5 (See Figure 202.)
 - A. Remove Horizontal Stabilizer Fillet
 - (1) Punch out mandrel in center of rivets with a small drift punch, then drill out rivet with a No. 30 drill.
 - (2) Remove fillet.
 - B. Install Horizontal Stabilizer Fillet
 - (1) Position fillet in place on fuselage.
 - (2) Install rivets.
5. Removal/Installation of Horizontal Stabilizer Fairing — Models AA-5A and AA-5B (See Figure 202.)
 - A. Remove Horizontal Stabilizer Fairing
 - (1) Remove screws and washers that secure fairing to horizontal stabilizer.
 - (2) Slide fairing forward to release channel base from clips and remove fairing.
 - B. Install Horizontal Stabilizer Fairing
 - (1) Position fairing in place on fuselage and slide back to engage channel base with clip.
 - (2) Install screws and washers that secure fairing to horizontal stabilizer.
6. Removal/Installation of Tailcone (See Figure 203.)
 - A. Remove Tailcone
 - (1) Remove screws that secure tailcone to aft fuselage.
 - (2) Slide tailcone back, disconnect tail light wires, and remove tailcone.
 - B. Install Tailcone
 - (1) Connect tail light wires at aft fuselage bulkhead.
 - (2) Perform functional check of tail light.
 - (3) Position tailcone to fuselage and install attaching screws.
7. Removal/Installation of Ventral Fin (See Figure 204.)
 - A. Remove Ventral Fin
 - (1) Remove nut, washer, and screw that secure fin to side brace struts.
 - (2) Punch out mandral in center of rivets with a small drift punch, then drill out rivets with a No. 30 drill.
Remove ventral fin.
 - B. Install Ventral Fin
 - (1) Position fin in place on fuselage and install rivets.
 - (2) Install screw, washer, and nut that secure side brace struts to fin.
8. Removal/Installation of Access Covers on Aft Fuselage (See Figure 1.)
 - A. Remove Access Covers
 - (1) Remove attaching screws that secure access covers to fuselage and remove covers.
 - B. Install Access Covers on Aft Fuselage
 - (1) Position covers in place on fuselage and install attaching screws.

AA-5 SERIES
MAINTENANCE MANUAL

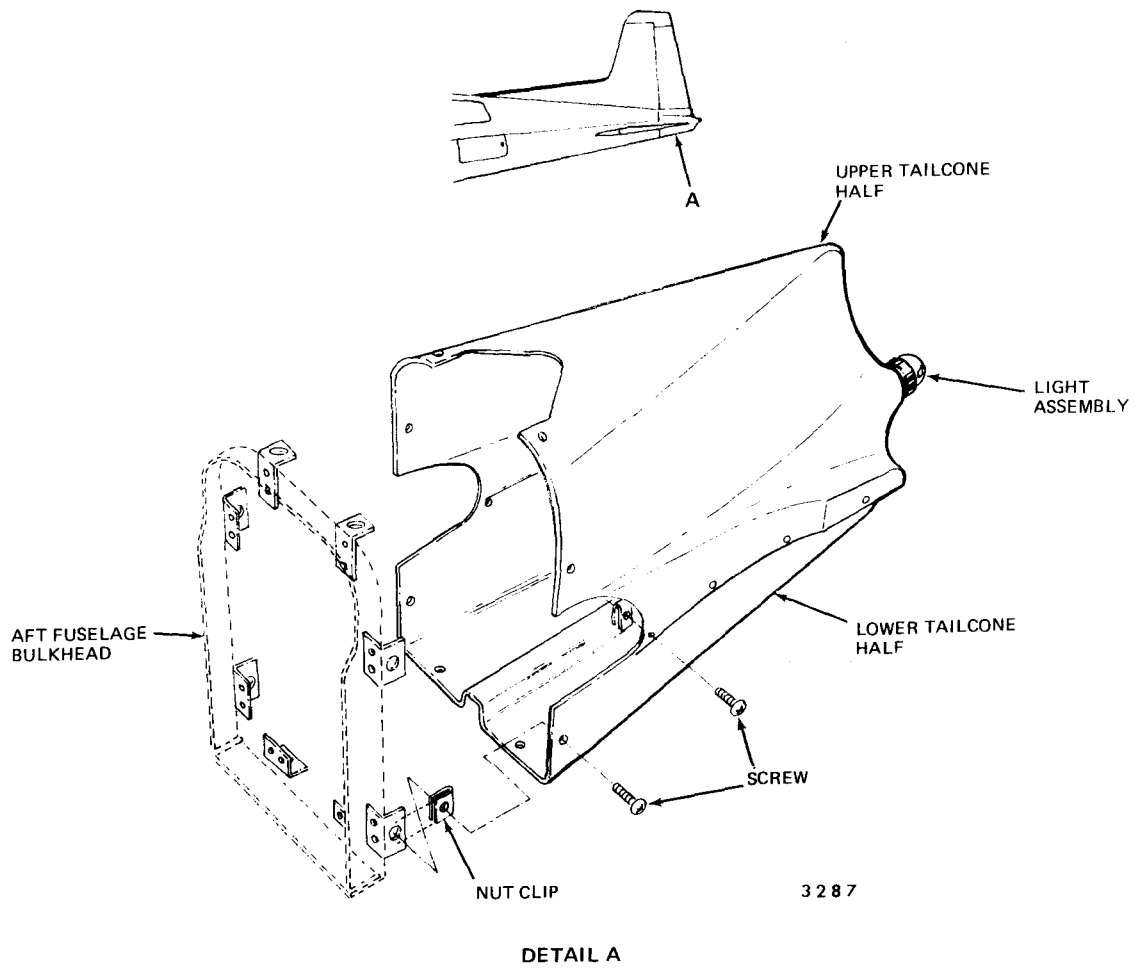

Tailcone Installation
Figure 203

AA-5 SERIES
MAINTENANCE MANUAL

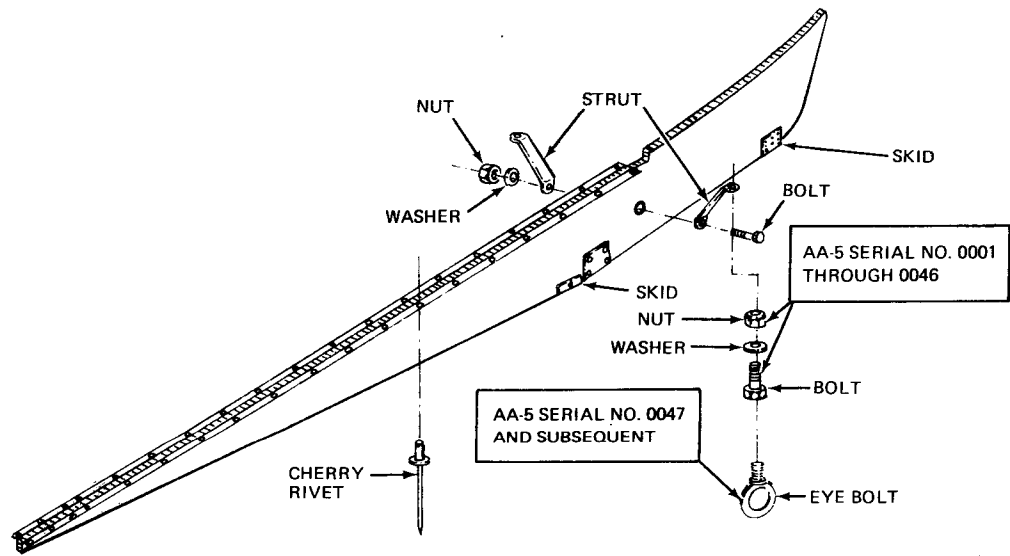
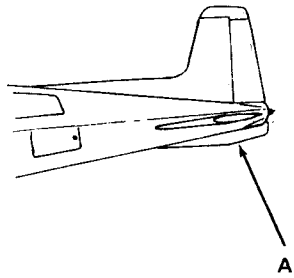

3286

DETAIL A

Ventral Fin Assembly
Figure 204

9. Removal/Installation of Brackets, Supports and Attach Fittings

Various brackets, supports, and attach fittings are considered components of the fuselage assembly. The cowlings attach brackets mounted on the upper firewall, the battery support bracket mounted on the lower firewall, the instrument panel support bracket, and the shoulder harness and baggage tiedown attach fittings are secured to the fuselage structure with either screws or bolts. Removal and replacement of these items require only a simple procedure of removing screws or bolts to detach the bracket or attach fitting. Install by positioning bracket or fitting in place and installing attaching bolts or screws.

AA-5 SERIES
MAINTENANCE MANUAL

CHAPTER 55

STABILIZERS

TABLE OF CONTENTS

| <u>NUMBER</u> | | <u>PAGE</u> |
|---------------|--|-------------|
| 55-0 | STABILIZERS | |
| | Description/Operation | 1 |
| | General | 1 |
| 55-1-1 | HORIZONTAL STABILIZERS | |
| | Description/Operation | 1 |
| | General | 1 |
| | Maintenance Practices | 201 |
| | Removal/Installation of Horizontal Stabilizer (AA-5 Aircraft) | 201 |
| | Removal/Installation of Horizontal Stabilizer (AA-5A and AA-5B Aircraft) | 203 |
| | Cleaning/Painting | 205 |
| 55-2-1 | VERTICAL STABILIZER | |
| | Description/Operation | 1 |
| | General | 1 |
| | Maintenance Practices | 201 |
| | Removal/Installation of Vertical Stabilizer | 201 |
| | Cleaning/Painting | 201 |

**AA-5 SERIES
MAINTENANCE MANUAL**

STABILIZERS - DESCRIPTION/OPERATION

1. General

The horizontal and vertical stabilizers are the fixed empennage structures to which the elevators and rudder are connected. In addition to providing attachment points for the control surfaces, the stabilizers assist in ensuring directional and longitudinal stability of the aircraft.

**AA-5 SERIES
MAINTENANCE MANUAL**

HORIZONTAL STABILIZERS - DESCRIPTION/OPERATION

1. General (See Figure 1 and 2.)

The horizontal stabilizers are of conventional dual spar and rib structure, with the skin bonded to the ribs and spars. On the AA-5 aircraft, the horizontal stabilizer has a tapered chord, wider at the root than the tip. On AA-5A and AA-5B aircraft the horizontal stabilizer is of constant chord configuration.

AA-5 SERIES
MAINTENANCE MANUAL

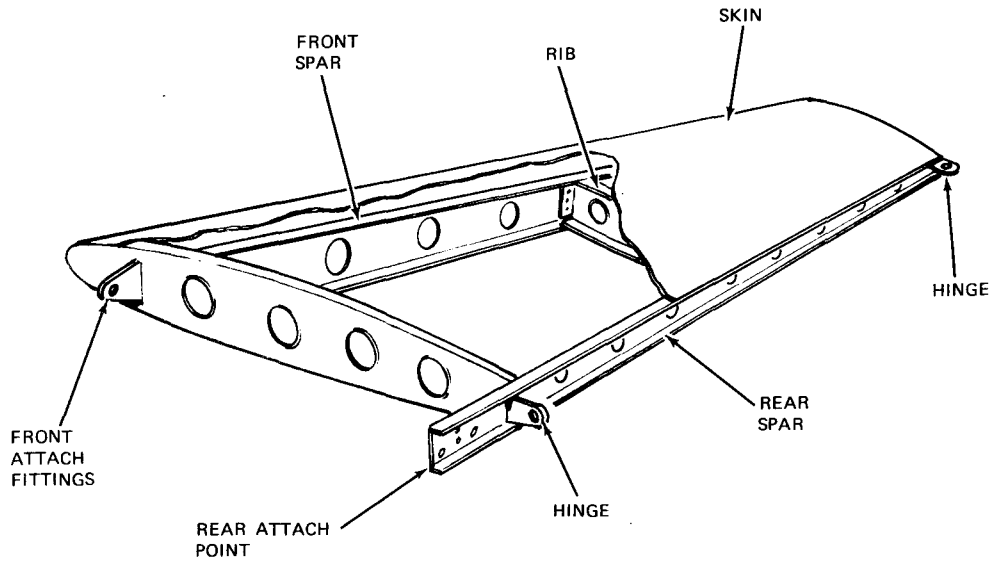

3512

Horizontal Stabilizer (AA-5)
Figure 1

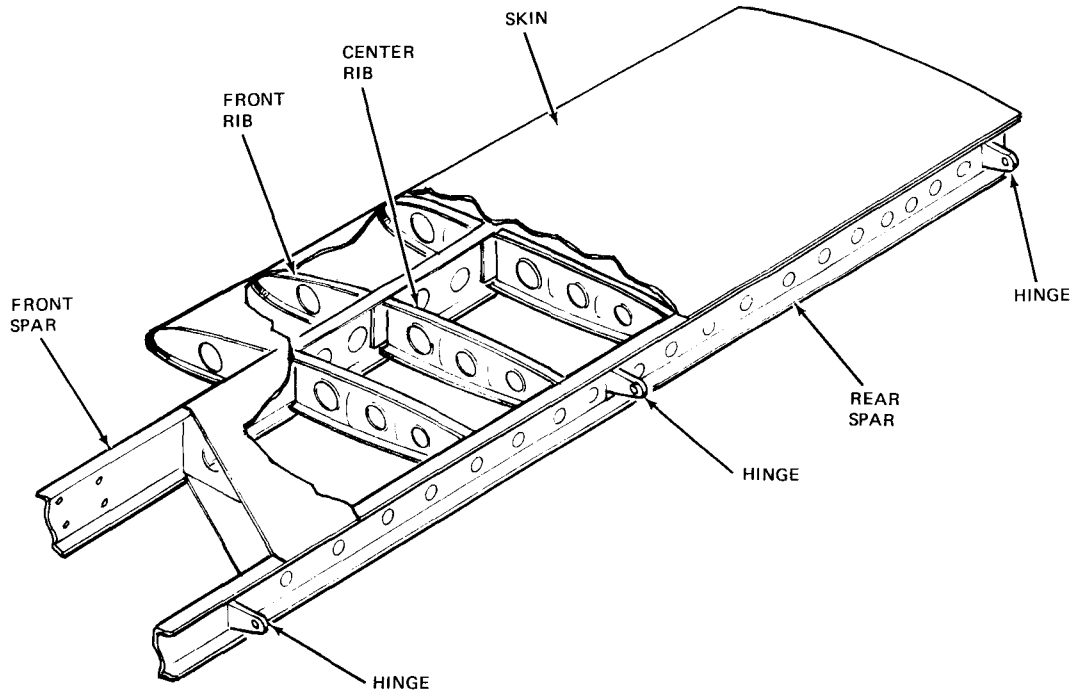

3513

Horizontal Stabilizer (AA-5A and AA-5B)
Figure 2

AA-5 SERIES
MAINTENANCE MANUAL

HORIZONTAL STABILIZERS - MAINTENANCE PRACTICES

1. Removal/Installation

A. Horizontal Stabilizer Removal (AA-5 Aircraft). (See Figure 201.)

NOTE: The horizontal stabilizer can be removed as an assembly with trim tabs and elevator intact, or by a disassembly procedure, whichever is required. If the trim tabs or elevators are being replaced, this can be accomplished without removing the stabilizer. However, if the right or left stabilizer half is being replaced, it may be advantageous to remove the stabilizer as an assembly. For complete stabilizer assembly removal, the following procedure may be used:

- (1) Remove tailcone and aft fuselage inspection covers below vertical fin. Refer to Chapter 53.
- (2) Disconnect elevator control cables and trim lever. Refer to Chapter 27.
- (3) Remove nuts (1), washers (2), and bolts (3) securing bearing (4).
- (4) Loosen lock nuts (5) and remove elevator stop bolts (6).

NOTE: Before removing horizontal stabilizer mounting bolts place stands beneath horizontal stabilizer to prevent its falling.

- (5) Remove forward attachment bolt (7) and washer (8).
- (6) Remove rear attachment bolts (9) and washers (10).
- (7) Spread stabilizer assembly apart at forward edge, just enough to free forward attaching lugs from fuselage and remove assembly from rear of aircraft.
- (8) When stabilizer is removed note position of shim (11) and spacers (12), in relation to spar stiffener flange (13).

NOTE: If only one side of the horizontal stabilizer is to be removed, proceed as follows:

- (9) Remove appropriate elevator. Refer to Chapter 27.
- (10) Remove appropriate aft fuselage inspection cover below vertical fin. Refer to Chapter 53.
- (11) Remove forward attach bolt (7) and washer (8).
- (12) Use a number 30 drill to drill out the ten rivets (14) and fourteen rivets (15) securing spar stiffener flange (13) to horizontal stabilizer (16).
- (13) Pull stabilizer (16) from aircraft.

B. Horizontal Stabilizer Installation (AA-5 Aircraft). (See Figure 201.)

NOTE: The horizontal stabilizer can be installed as an assembly with trim tabs and elevator intact, or by build-up, whichever is required. If the right or left stabilizer half is being replaced it may be advantageous to install the stabilizer as an assembly. For complete stabilizer assembly installation, the following procedure may be used:

- (1) Position stabilizer in its installed location and spread assembly apart at forward edge enough to allow forward attaching lugs to enter access openings in fuselage.

AA-5 SERIES
MAINTENANCE MANUAL

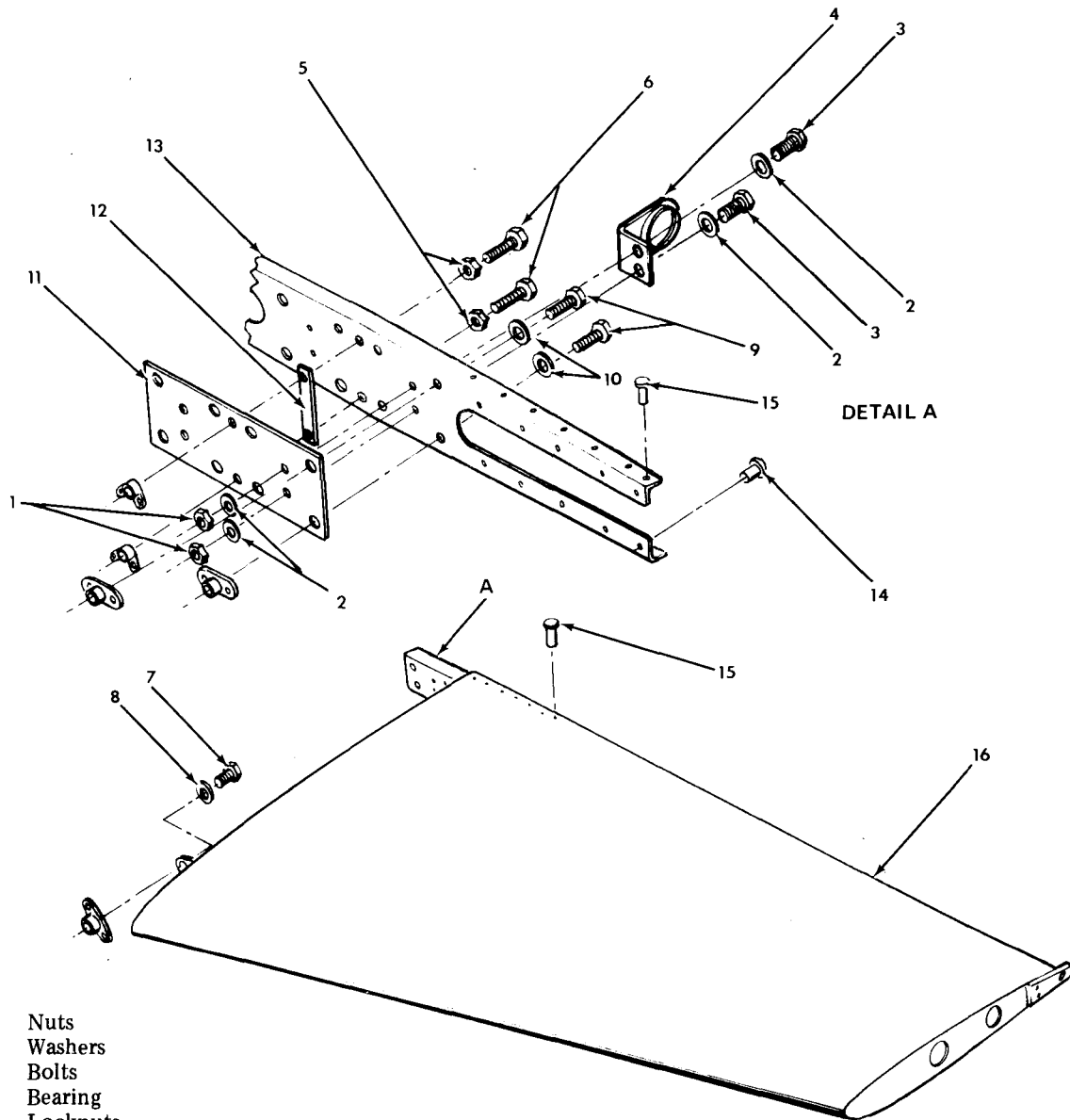

1. Nuts
2. Washers
3. Bolts
4. Bearing
5. Locknuts
6. Stop Bolts
7. Bolt
8. Washer
9. Attach Bolts
10. Washers
11. Shim
12. Spacers
13. Flange
14. Rivets
15. Rivets
16. Stabilizer

3514

Horizontal Stabilizer Removal/Installation (AA-5 Aircraft)
Figure 201

**AA-5 SERIES
MAINTENANCE MANUAL**

- (2) Secure forward attaching lugs to fuselage with bolts (7) and washers (8). Torque to standard value. (Refer to Chapter 91.)
- (3) Position shim (11) and spacers (12) between spar stiffener flange (13) and fuselage aft bulkhead.
- (4) Align bolt holes and secure with bolts (9) and washers (10). Torque to standard value. (Refer to Chapter 91.)
- (5) Screw lock nuts (5) on bolts (6) and install bolts (6). Do not tighten bolts.
- (6) Align bearing (4) mounting holes with holes in spar stiffener flange (13). Secure with bolts (3), washers (2), and nuts (1). Torque to standard value. (Refer to Chapter 91.)
- (7) Connect elevator controls and rig. (Refer to Chapter 27.)
- (8) Install aft fuselage inspection covers and tailcone. (Refer to Chapter 53.)

NOTE: If only one side of the horizontal stabilizer is to be removed, proceed as follows:

- (9) Position horizontal stabilizer on spar stiffener flange and secure with ten rivets (14) (Part Number MS-20470AD4-5) and fourteen rivets (15) (Part Number MS-20426AD4-5).
- (10) Secure attaching lug to fuselage with bolt (7) and washer (8). Torque to standard value. (Refer to Chapter 91.)
- (11) Connect elevator controls and rig. (Refer to Chapter 27.)
- (12) Install aft fuselage inspection covers and tailcone. (Refer to Chapter 53.)

C. Horizontal Stabilizer Removal (AA-5A and AA-5B Aircraft). (See Figure 202.)

NOTE: The horizontal stabilizer can be removed as an assembly with trim tabs and elevator intact, or by a disassembly procedure, whichever is required. If the trim tabs or elevators are being replaced, this can be accomplished without removing the stabilizer, elevators, and trim tabs as an assembly. For complete stabilizer assembly removal, the following procedure may be used:

- (1) Remove tailcone and aft fuselage inspection covers below vertical fin. (Refer to Chapter 53.)
- (2) Disconnect elevator control cables and trim lever. (Refer to Chapter 27.)
- (3) Remove horizontal stabilizer fairings. (Refer to Chapter 53.)
- (4) Remove forward mounting bolts (1) and washers (2) on each side of fuselage.
- (5) Remove hinge mounting bolts (3) and washers (4).
- (6) Remove spar attach bolts (5) and washers (6).
- (7) Remove elevator stop bolts (7) and spacers (8).
- (8) Pull horizontal stabilizer aft and remove from aircraft.

D. Horizontal Stabilizer Installation (AA-5A and AA-5B Aircraft). (See Figure 202.)

AA-5 SERIES
MAINTENANCE MANUAL

1. Forward Mounting Bolts
2. Washers
3. Hinge Mounting Bolts
4. Washers
5. Spar Attach Bolts
6. Washers
7. Elevator Stop Bolts
8. Spacers
9. Hinge

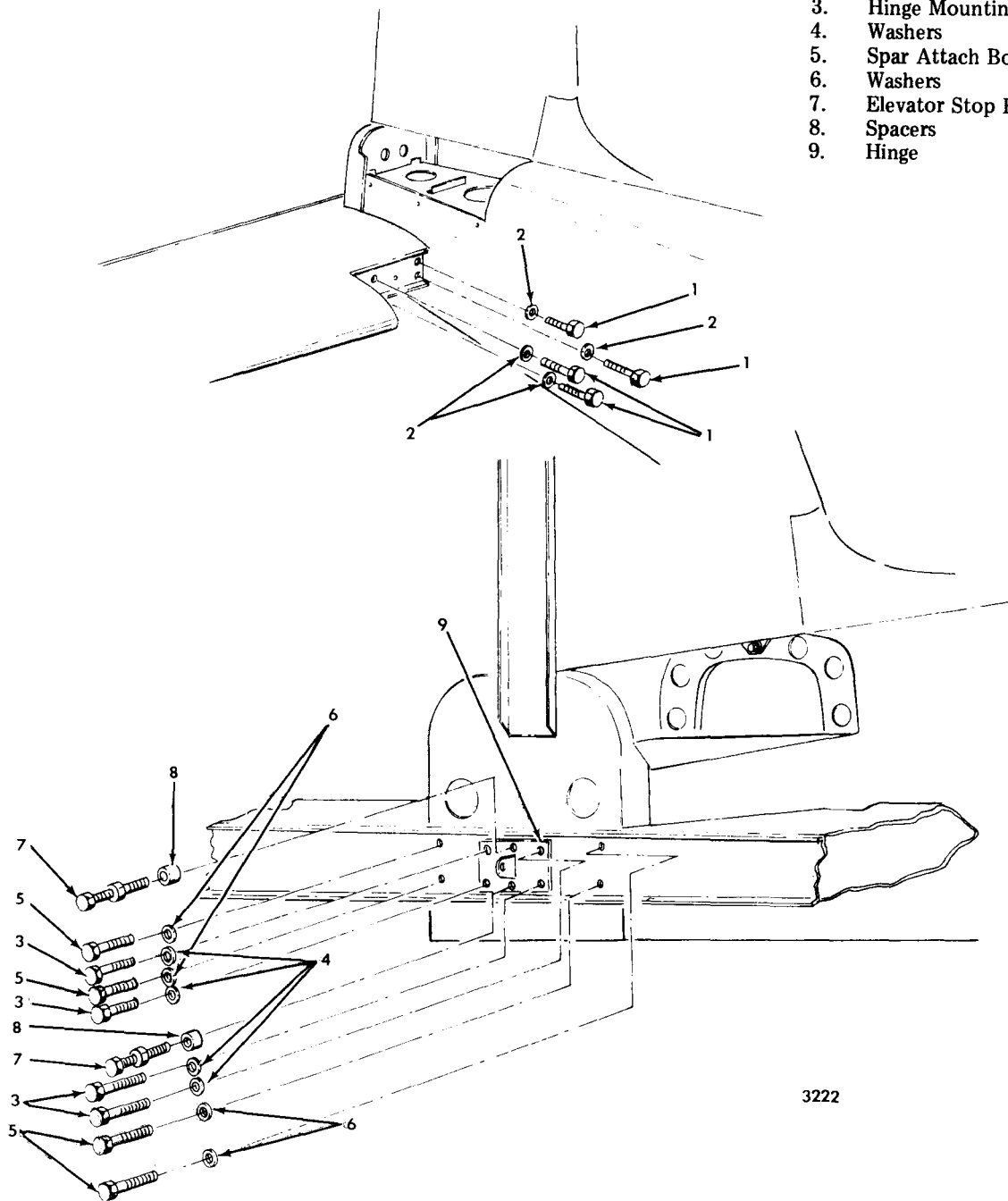

3222

Horizontal Stabilizer Removal/Installation (AA-5A and AA-5B Aircraft)
Figure 202

**AA-5 SERIES
MAINTENANCE MANUAL**

- (1) Position horizontal stabilizer to its installed location and secure forward spar with bolts (1) and washers (2). Torque to standard value. (Refer to Chapter 91.)
 - (2) Install aft spar mounting bolts (5) and washers (6). Torque to standard value. (Refer to Chapter 91.)
 - (3) Position hinge (9) on aft spar and secure with bolts (3) and washers (4).
 - (4) Install elevator stops (7) and spacers (8).
 - (5) Connect elevator and trim linkages, and rig. (Refer to Chapter 27.)
 - (6) Install tailcone, aft fuselage inspection covers and fairings. (Refer to Chapter 53.)
2. Cleaning/Painting
- Clean and paint horizontal stabilizer. (Refer to Chapter 20.)

AA-5 SERIES
MAINTENANCE MANUAL

VERTICAL STABILIZER - DESCRIPTION/OPERATION

1. General (See Figure 1.)

The vertical stabilizer is of conventional dual spar and rib construction, with its skin bonded to the ribs and spars. It has a tapered chord, with its maximum chord at the root, and its minimum chord at the tip.

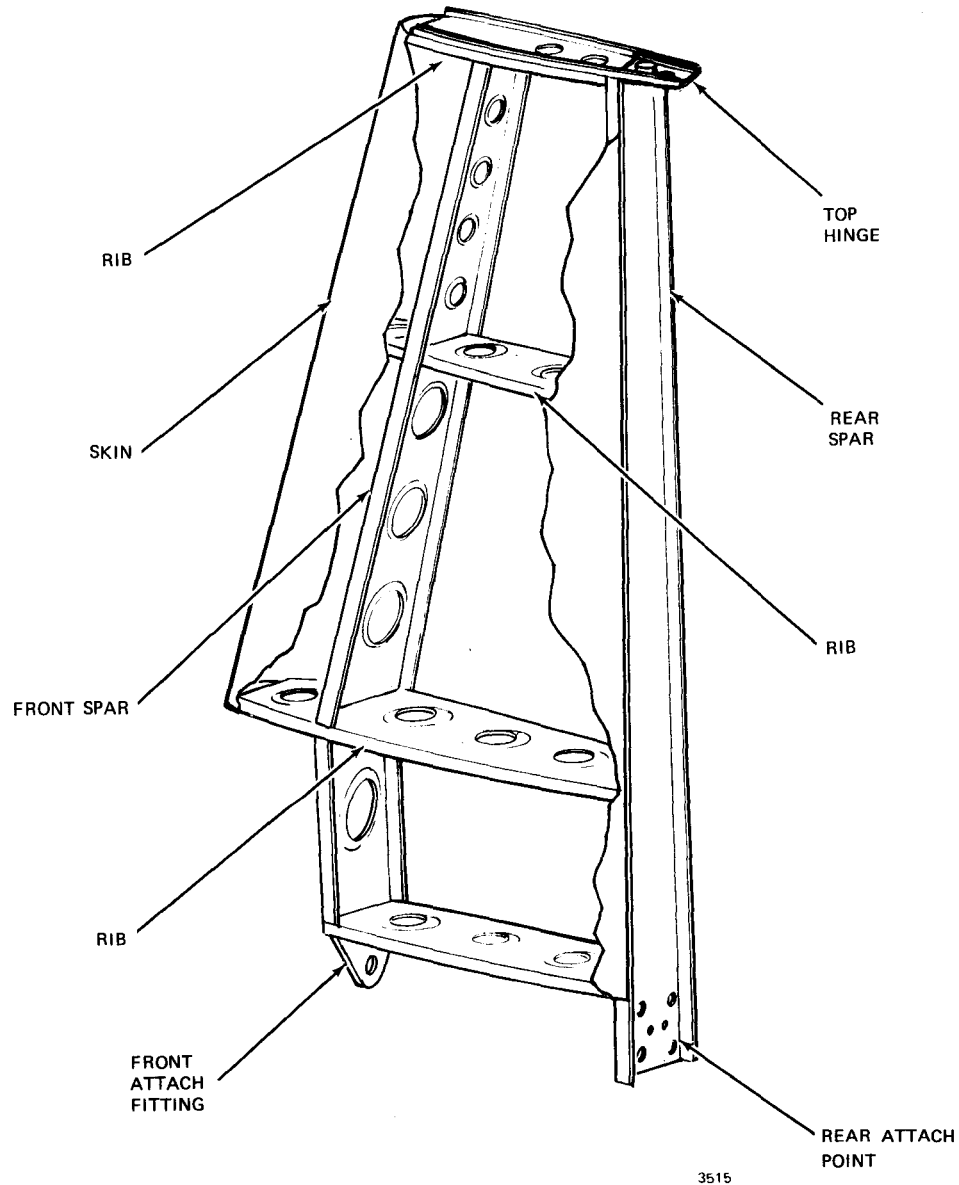

Vertical Stabilizer
Figure 1

AA-5 SERIES
MAINTENANCE MANUAL

VERTICAL STABILIZER - MAINTENANCE PRACTICES

1. Removal/Installation

A. Vertical Stabilizer Removal (See Figure 201.)

NOTE: The vertical stabilizer can be removed as an assembly with rudder intact, or by a disassembly procedure, whichever is required. If the rudder is being replaced this can be accomplished without removing the vertical stabilizer. (Refer to Chapter 27 for rudder removal.) for stabilizer and rudder removal as an assembly, proceed as follows:

- (1) Remove tailcone and aft fuselage inspection covers. (Refer to Chapter 53.)
- (2) Disconnect rudder cables. (Refer to Chapter 27.)
- (3) Remove front attachment bolt (1) and washer (2).
- (4) Remove aft attachment bolts (3) and washers (4).
- (5) Disconnect antenna and rotating beacon wiring. (Refer to Chapter 27.)
- (6) Remove vertical stabilizer and rudder from aircraft.

B. Vertical Stabilizer Installation (See Figure 201.)

- (1) Position vertical stabilizer and rudder on aircraft so that its rear mounting holes are aligned with those in fuselage. Secure with rear mounting bolts (3) and washers (4). Torque to standard value. (Refer to Chapter 91.)
- (2) Align hole in forward mount with hole in fuselage. Secure with bolt (1) and washer (2). Torque to standard value. (Refer to Chapter 91.)
- (3) Connect antenna and rotating beacon wiring. (Refer to Chapter 27.)
- (4) Connect rudder cables and rig rudder. (Refer to Chapter 27.)
- (5) Install tailcone, and aft inspection covers. (Refer to Chapter 53.)

2. Cleaning/Painting

Clean and paint vertical stabilizer. (Refer to Chapter 20.)

AA-5 SERIES
MAINTENANCE MANUAL

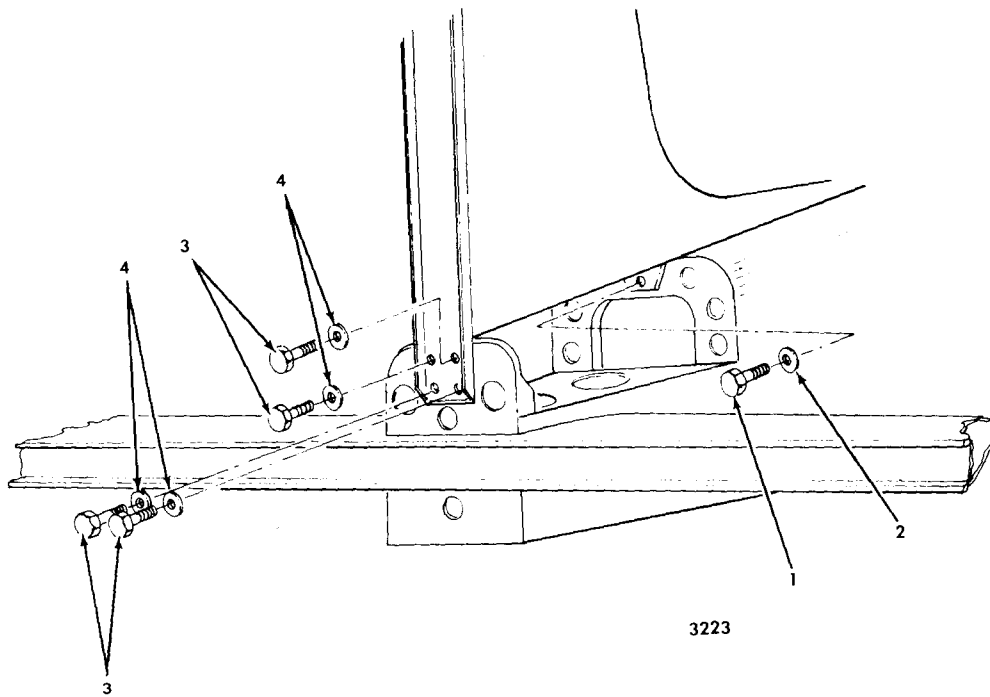

1. Front Attach Bolt
2. Washer
3. Aft Attachment Bolts
4. Washers

Vertical Stabilizer Removal/Installation
Figure 201

CHAPTER 56

WINDOWS

TABLE OF CONTENTS

| <u>NUMBER</u> | | <u>PAGE</u> |
|---------------|---|-------------|
| 56-0 | WINDOWS | |
| | Description | 1 |
| | General | 1 |
| | Windshield | 1 |
| | Canopy and Aft Fuselage Cabin Windows | 1 |
| | Maintenance Practices | 201 |
| | Removal/Installation of Windshield | 201 |
| | Removal/Installation of Aft Fuselage Window | 203 |
| | Removal/Installation of Canopy Window | 203 |
| | Cleaning | 203 |

WINDOWS — DESCRIPTION

1. General

The windshield, canopy windows, and aft fuselage cabin windows are constructed of plexiglas, with a 0.125 inch thickness. Tinted plexiglas is optional.

2. Windshield

The plexiglas windshield and frame assembly are bonded together and serviced as a single unit. The windshield is attached to the forward fuselage and, due to its wrap-around design, affords excellent visibility. The windshield is heated by means of two defroster vents located on the deck assembly.

3. Canopy and Aft Fuselage Cabin Windows

The canopy and aft fuselage cabin windows are held in position by retaining strips. Sealing of the windows consists of a sealing compound used along with a felt seal around the window edges.

**AA-5 SERIES
MAINTENANCE MANUAL**

WINDOWS — MAINTENANCE PRACTICES

1. Removal/Installation

A. Windshield Removal (See Figure 201.)

- (1) Remove glareshield and deck assemblies. Refer to Chapter 25.
- (2) Remove instrument light plastic housing and map light plastic housing on each side of glareshield panel.
- (3) Remove the screws (5), washers (3), and nuts (4) securing the windshield to the forward fuselage.
- (4) Remove the screws (6), washers (3), and nuts (4) where windshield bow is secured to the fuselage assembly.
- (5) Remove the nuts (4), washers (3), and bolts (2) which attach the windshield bow support (8) to the fuselage and remove the windshield from the aircraft.

WARNING: WHEN USING TRICHLORETHYLENE OR MEK, ENSURE THAT THE WORKING AREA IS WELL-VENTILATED AND THAT PROTECTIVE EQUIPMENT (GLOVES, EYE PROTECTION) IS WORN. KEEP AWAY FROM FLAMES.

CAUTION: AVOID ALLOWING TRICHLORETHYLENE OR MEK TO CONTACT PAINTED SURFACES. THESE SOLVENTS HAVE A CORROSIVE EFFECT UPON PAINTED SURFACES.

- (6) Remove old seal. Remove adhesive residue from upper forward fuselage assembly with trichlorethylene or MEK. Wipe the surface with a clean dry cloth before the solvent evaporates.

B. Windshield Installation (See Figure 201.)

- (1) Make sure faying surfaces of windshield and upper forward fuselage assembly are clean and dry.
 - (a) The plexiglas faying surface may be cleaned with a cloth moistened with aliphatic naphtha.
 - (b) For preparation of upper forward fuselage faying surface, see Step (6) in Paragraph 1 above. Observe warning and caution.
- (2) With faying surface of upper forward fuselage assembly clean and dry, press adhesive surface of 522 vinyl foam tape against upper forward fuselage assembly.
- (3) With faying surface of windshield clean and dry, apply sealant (Presstite) to faying surfaces of windshield and upper forward fuselage assembly. Apply sealant by hand. If sealant flows out after joint is mated, the excess may be wiped off.
- (4) Align hole at bottom of windshield bow support with hole in bracket. Install bolts (2), washers (3), and nuts (4) which attach the windshield bow support (8) to the bracket (10).

NOTE: For new windshields, position bow vertically parallel with forward canopy bow in alignment with canopy contour and carefully drill mounting holes 0.312 inches in diameter through plexiglas.

CAUTION: WHEN DRILLING HOLES THROUGH PLEXIGLAS, EXERCISE CARE TO PREVENT CRACKING WINDSHIELD OR ELONGATING MOUNTING HOLES.

- (5) Install screws (6), washers (3), and nuts (4) when windshield bow is secured to fuselage assembly.

AA-5 SERIES
MAINTENANCE MANUAL

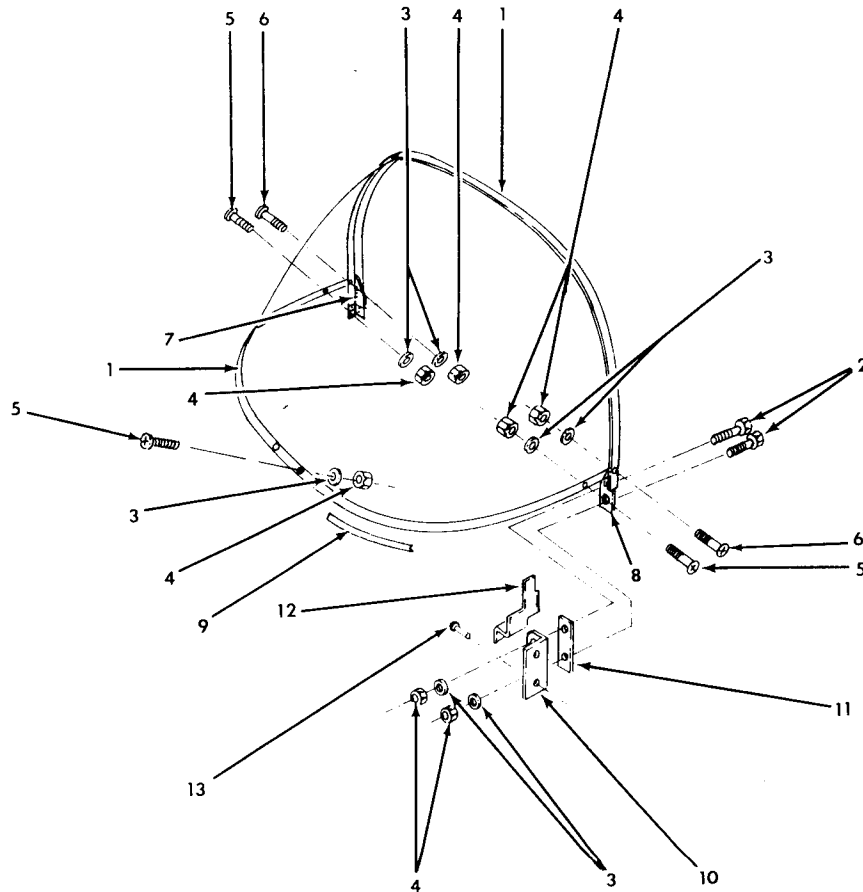

- | | |
|------------------------|----------------------|
| 1. Windshield Assembly | 8. Support |
| 2. Bolt | 9. Tape (Vinyl Foam) |
| 3. Washer | 10. Bracket |
| 4. Nut | 11. Shim |
| 5. Screw | 12. Retainer |
| 6. Screw | 13. Rivet |
| 7. Rivet | |

Windshield Installation
Figure 201

- (6) Install screws (5), washers (3), and nuts (4) securing the windshield to the forward fuselage and torque 8 to 12 inch-pounds.
- (7) For proper seal compression, install additional shims (11) to bracket.

2. Removal/Installation of Aft Fuselage Window

A. Aft Fuselage Window Removal

- (1) Remove aft fuselage moulding. (Refer to Chapter 25.)
- (2) Remove screws from the five retaining strips mounted around the edge of the window and remove window.
- (3) Remove old felt seal from edge of windows.
- (4) Remove Prestite sealant from fuselage area where window was mated.

B. Aft Fuselage Window Installation

- (1) Clean area around edges of window where adhesive tape seal is to be placed. Use cloth moistened with aliphatic naphtha.
- (2) Apply felt seal around edges of window.
- (3) Apply Prestite sealant by hand to fuselage area where window is to be mated.
- (4) Place window to fuselage mating surface and install five retaining strips around edges of window. If sealant flows out after joint is mated, the excess should be wiped off.
- (5) Install aft fuselage moulding. (Refer to Chapter 25.)

3. Removal Installation of Canopy Window

For canopy window removal and installation procedures, refer to Chapter 52.

4. Cleaning

A. Windshield and Window Cleaning

It is recommended that plexiglas in the canopy, windshield, and cabin windows be kept clean and unscratched. The following procedures are recommended:

CAUTION: DO NOT USE GASOLINE, ALCOHOL, BENZINE, ACETONE, CARBON TETRACHLORIDE, OR GLASS WINDOW CLEANER. THESE FLUIDS CAN DAMAGE THE PLEXIGLAS.

- (1) If large deposits of mud and/or dirt have accumulated on the plexiglas, flush with clean water. Rubbing with your hand is recommended to dislodge excess dirt and mud without scratching the plexiglas.
- (2) Wash with soap and water. Use a sponge or heavy wadding of a soft cloth. DO NOT rub, as the abrasive action in the dirt and mud residue will cause fine scratches in the surface.
- (3) Grease and oil spots may be removed with a soft cloth soaked in kerosene.
- (4) After cleaning, wax the plexiglas surface with a thin coat of hard polish or wax. Buff with a soft cloth.
- (5) If a severe scratch or marring occurs, jeweler's rouge is recommended. Follow directions, rub out scratch, smooth, apply wax, and buff.

AA-5 SERIES
MAINTENANCE MANUAL

CHAPTER 57

WINGS

TABLE OF CONTENTS

| <u>NUMBER</u> | | <u>PAGE</u> |
|---------------|--------------------------------|-------------|
| 57-0 | WINGS | |
| | Description | 1 |
| | General | 1 |
| | Wing Root | 1 |
| | Wing Tips | 1 |
| | Wing Interchangeability | 1 |
| | Maintenance Practices | 201 |
| | Wing Removal/Installation | 201 |
| | Wing Root Removal/Installation | 207 |
| | Wing Tip Removal/Installation | 208 |
| | Wing and Center Spar Repair | 209 |

**AA-5 SERIES
MAINTENANCE MANUAL**

WINGS - DESCRIPTION

1. General

The wings consist of all-metal structures bonded to ribs and incorporate the ailerons, flaps, fuel tanks, fuel sump tanks, wing tip assemblies and navigation lights. The AA-5, AA-5A, and AA-5B models have a wing span of 31 feet and 6 inches.

Each wing half consists of two assemblies, the inner and outer wing panels. The inner and outer wing panels are bolted together and the outer can be removed and replaced separately. The wing halves are bonded around tubular spars which attach to the main spar located in the fuselage. The wing halves are built and bonded in jig fixtures at the factory.

2. Wing Root

The wing root is located between the wing and fuselage and provides a smooth fusing of the wing assembly to the fuselage. The wing root encloses the upper main landing gear attaching brackets and fuel sumps and lines to the fuel tanks.

3. Wing Tips

The wing tips are the outermost part of the wing assembly. They blend the wing leading edge and trailing edge into a single unit. The wing tips house the aileron balance weight assemblies and contain the navigation lights.

4. Wing Interchangeability

Wing components are interchangeable only as follows:

| <u>WING PANEL COMPONENT</u> | <u>MODEL INTERCHANGEABILITY</u> |
|--|---|
| LH Outer | AA-5, AA-5A and AA-5B |
| AA-5 LH Inner | AA-5A LH Inner, std. tank |
| AA-5A RH Outer | AA-5B RH Outer |
| AA-5A LH Inner, std. tank | AA-5 LH Inner |
| AA-5A LH Inner, Opt. tank | AA-5B LH Inner with or without fuel gauging tab |
| AA-5A RH Inner, Opt. tank | AA-5B RH Inner with or without fuel gauging tab |
| AA-5B RH Outer | AA-5A RH Outer |
| AA-5B LH Inner with fuel gauging tab | AA-5A LH Inner, Opt. tank and AA-5B LH Inner without fuel gauging tab |
| AA-5B LH Inner without fuel tab | AA-5B LH Inner with fuel gauging tab |
| AA-5B RH Inner with fuel gauging tab | AA-5A RH Inner, Opt. tank and AA-5B RH Inner without fuel gauging tab |
| AA-5B RH Inner without gauging tab | AA-5B RH Inner with fuel gauging tab |

WINGS — MAINTENANCE PRACTICES

1. Wing Removal/Installation

A. Wing Removal

NOTE: The wing halves can be removed as assemblies with the wing tips, ailerons, and flaps intact, or they can be removed by a disassembly procedure, whichever is required. If the wing is being removed for transportation or storage, use the following procedure. If it is being removed for sectional repair, it may be advantageous to remove the wing tip (See Paragraph I and J, Wing Tip Removal and Wing Tip Installation), aileron (refer to Chapter 27, Aileron Removal), and flap (refer to Chapter 27, Flap Removal), prior to the following procedure.

NOTE: Numbers in parentheses refer to callouts in figures.

- (1) Remove the screws (1, Figure 201), attaching the access panel (2) to the wing root (3).
- (2) From within the wing root, remove the shoulder bolts (1, Figure 202) and washers (2).
- (3) Disconnect the airspeed pitot line located in the wing root (left side only).
- (4) Drain the fuel from the main tank and sump (Refer to Refueling/Defueling, Chapter 28.) and disconnect the fuel lines to the wing root.
- (5) Disconnect all wiring in the wing root.
- (6) Tilt the rear seat forward and remove the access cover.

CAUTION: DO NOT DISTURB THE CABLE TURNBUCKLES OR CONTROL SURFACE RIGGING.

- (7) Remove the nut and bolt securing the aileron horn to the torque tube and remove it from the torque tube by rotating and sliding from the end of the tube. (See Figure 203.)
- (8) Disconnect the flap drive linkage from the flap torque tube horn (1, Figure 204) assembly located under the rear seat.

NOTE: On Aircraft AA5-0001 through AA5-0050, cut safety wire (2, Figure 204) securing the two special drive bolts (3).

- (9) Remove the two special drive bolts (3, Figure 204) from the flap torque tube bellcrank (4). Loosen the bellcrank clamp bolt and slide the bellcrank from the torque tube.

CAUTION: EXERCISE CARE TO PREVENT FLAP "OVERTRAVEL" WHICH MAY RESULT IN THE SCRATCHING OF PAINT OR SKINS.

- (10) Place two men at the wing tip to support wing weight and to be ready to pull wing out.
- (11) Place one man inside the aircraft to make sure torque tubes do not bind.
- (12) Place one man at the inboard leading edge and another man at inboard trailing edge and rotate the wing slightly clockwise and counterclockwise until the wing is free of the spar. Pull wing outboard from the fuselage.

B. Wing Disassembly

NOTE: Before disassembly of the wing, remove the wing tip (See Paragraphs 3A and 3B, Wing Tip Removal and Wing Tip Installation.), the aileron (Refer to Aileron Removal, Chapter 27.), and the flaps. (Refer to Flap Removal, Chapter 27.)

**AA-5 SERIES
MAINTENANCE MANUAL**

NOTE: Numbers in parentheses refer to callouts in Figure 202.

- (1) Locate the trailing edge end of the wing seam strap (3) binding the inner and outer wing panels. At the outboard side of the wing seam strap, drill out the rivets (one at the top of the wing, one on the underneath side of the wing).
- (2) Remove four bolts (4) from the splice plate assembly (5) at the junction of the inner and outer panels.
- (3) Remove two outboard access covers from bottom side of inner wing panel.
- (4) Through the access holes, disconnect the fuel vent lines.
- (5) In the left hand wing half, disconnect the airspeed pitot line.
- (6) Through the access holes, remove the shoulder bolts (6) and washers (7).
- (7) Work the wing panels partially apart by rotating the panels slightly clockwise until the navigation light wires and stall warning switch wires (right wing) are exposed. Cut these wires near the center for easier splicing on reassembly.
- (8) Continue rotating the wing panels slightly until separated.

C. Wing Reassembly

- (1) Spray the wing panel spar mating surfaces with a solid film lubricant and rub general purpose lubricating oil over the inner wing panel spar mating surface. Approved solid film lubricants are:
 - (a) McLube 1708 by McGee Chemical Co., Inc.
 - (b) Lube-Lok 5396 by Allen Aircraft Products, Inc.
- (2) Work the inner and outer wing panel spars together approximately 3 inches.
- (3) Slide a short length of shrink tubing over each navigation light wire and splice wires with quick-connects.
- (4) Slide shrink tube over connections and shrink for tight seal. On the right hand wing panels, also splice and apply shrink tubing to the stall warning switch wiring.

NOTE: Numbers in parentheses refer to callouts in Figure 202.

- (5) Continue sliding the wing panels together, using caution to assure that the ABS plastic spacer (8) under the splice strap (3), slides over the wing skin.
- (6) When the spar attach bolts are aligned, install the shoulder bolts (6) and washers (7). Torque the spar attach bolts 60 to 85 in. lb.
- (7) Install splice plate assembly (5) at the junction of the inner and outer panels with four bolts (4) and washers (9). Torque bolts 20 to 25 in. lb.
- (8) Through the access hole, connect the fuel vent lines. On left side, connect the airspeed pitot line.
- (9) Install access covers (10) with screws (11).
- (10) Install the rivets in the trailing edges of the wing seam splice strap on the top and bottom of the rear spar.

**AA-5 SERIES
MAINTENANCE MANUAL**

D. Wing Installation

- (1) Spray the spar mating surfaces with a solid film lubricant and rub general purpose lubricating oil over the fuselage carry-through spar. See C(1) above for approved lubricants.
- (2) Tilt the rear seat forward and remove the access cover to gain access to the flap and aileron control assemblies. Place one man inside the aircraft to adjust the aileron and flap tube assemblies when inserted through the wing root and fuselage.
- (3) Place one man at the wing tip, one man at the inboard leading edge, and another man at the inboard trailing edge.
- (4) With all three men lifting, lift the wing and align the center spar with the wing spar and align the torque tube assembly with aft hole in the wing root.
- (5) Carefully install wing spar to center spar, with man stationed in aircraft aligning flap tube to flap bearing and aileron tube to aileron horn assembly.
- (6) Prior to installation of shoulder bolts, shake wing vertically and horizontally to check for looseness. If looseness is noted at the wing tip, proceed with the following steps:
 - (a) Apply a 25 pound down load at the wing tip and measure gap at top of spar, between center spar and wing spar, using a wire type feeler gauge. If gap exceeds 0.016 inch, shim to reduce gap to not more than 0.008 inch (unshimmed gap less shim thickness) as described in Steps (b) through (f) below. (See Figure 205.)
 - (b) Sand edges of the shim(s) down to remove sharp corners.
 - (c) Place the shim(s) on the top and/or bottom of the inboard spar as required.
 - (d) Bend approximately 1.25 inches of the outboard end of the shim(s) over the ends and inside the inboard spar.
 - (e) Bend over the inboard end(s) of the shim(s) so that this portion will wrap over the end of the outboard wing spar when the wing is fully installed.
 - (f) Before wing installation, coat surfaces of shim(s) with McLube 1708 solid film lubricant or equivalent.

NOTE: Numbers in parentheses refer to callouts in figures.

- (7) Slide the flap torque tube bellcrank (4, Figure 204) over the flap torque tube. Tighten bellcrank clamp bolt.
 - (8) Install special drive bolts (3) to flap bellcrank, making sure bolts are properly indexed in torque tube hole, and tighten. Bolt should be flush minimum and extend not more than 0.032 inch.
- NOTE: Install safety wire (2) to bolts for Aircraft AA5-0001 through AA5-0050.
- (9) Connect flap drive linkage to flap torque tube horn assembly.
 - (10) Install the nut and bolt securing the aileron horn to the torque tube. (See Figure 203.) Torque bolt 95 inch-pounds maximum.
 - (11) Connect all electrical wiring and fuel lines in the wing root.
 - (12) Connect the airspeed pitot line located in the wing root (left-side of aircraft).

AA-5 SERIES
MAINTENANCE MANUAL

- (13) Through access panel (2, Figure 201) on wing root, install shoulder bolts and washers (1 and 2, Figure 202). Torque shoulder bolts to 120 inch-pounds.
- (14) Install the screws (1, Figure 201) attaching the access panel (2) to the wing root (3).

NOTE: If the original wing is replaced by a new wing, the outboard stall strip (item (15), Figure 202) should be centered on a line drawn 0.31 inch up from the flap surface on the bottom side of the wing and taped in place and the aircraft test flown to "fine tune" the wing. Perform a series of stalls at half throttle and move the stall strip slightly up or down (maximum 1/8 inch), as required, to obtain a straight ahead stall and rivet in place.

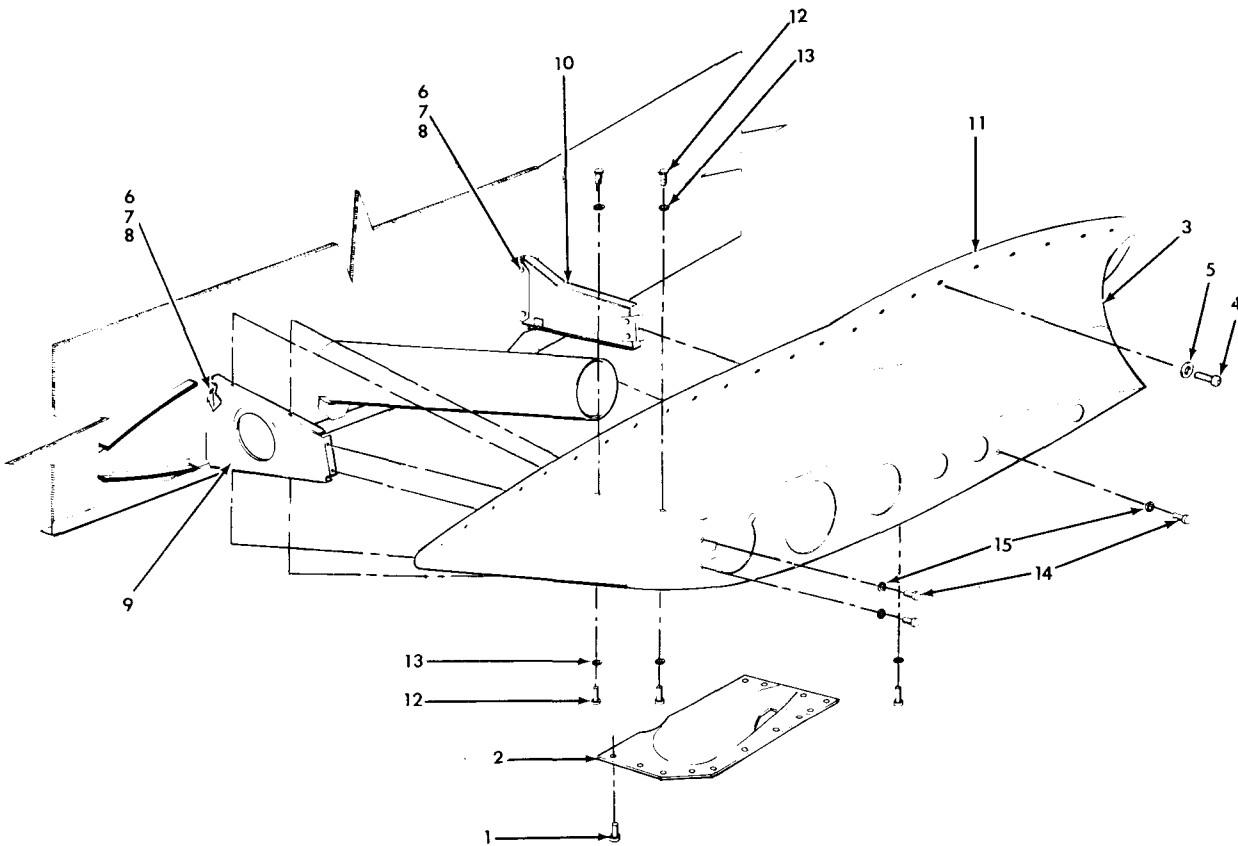

- | | |
|-----------------|-------------|
| 1. Screw | 9. Support |
| 2. Access Panel | 10. Support |
| 3. Wing Root | 11. Seal |
| 4. Screw | 12. Screw |
| 5. Washer | 13. Washer |
| 6. Bolt | 14. Bolt |
| 7. Washer | 15. Washer |
| 8. Spacer | |

Wing Root Installation (L.H.)
Figure 201

AA-5 SERIES
MAINTENANCE MANUAL

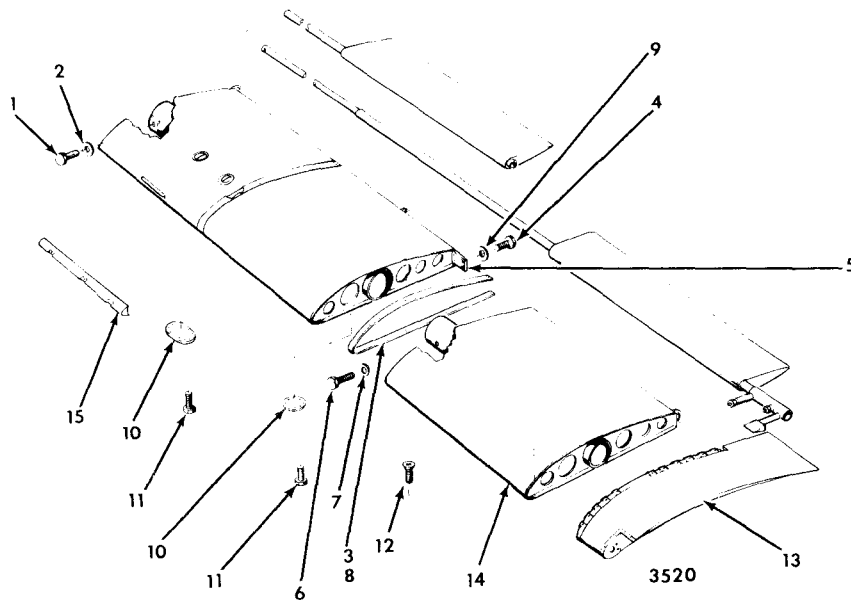

- | | |
|--------------------------|--------------------------|
| 1. Shoulder Bolt | 9. Washer |
| 2. Washer | 10. Cover |
| 3. Strap | 11. Screw |
| 4. Bolt | 12. Screw |
| 5. Splice Plate Assembly | 13. Wing Tip Assembly |
| 6. Shoulder Bolt | 14. Outer panel Assembly |
| 7. Washer | 15. Stall Strip |
| 8. Spacer | |

Wing Half (L. H.)
Figure 202

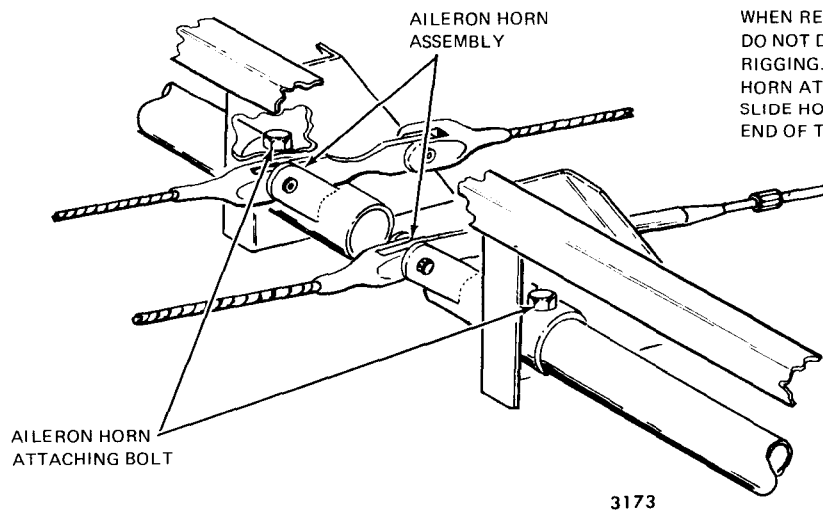

Aileron Torque Tube Horn Assemblies
Figure 203

NOTE
WHEN REMOVING AILERONS,
DO NOT DISTURB AILERON
RIGGING. REMOVE THE AILERON
HORN ATTACHING BOLT AND
SLIDE HORN ASSEMBLY FROM
END OF TORQUE TUBE.

AA-5 SERIES
MAINTENANCE MANUAL

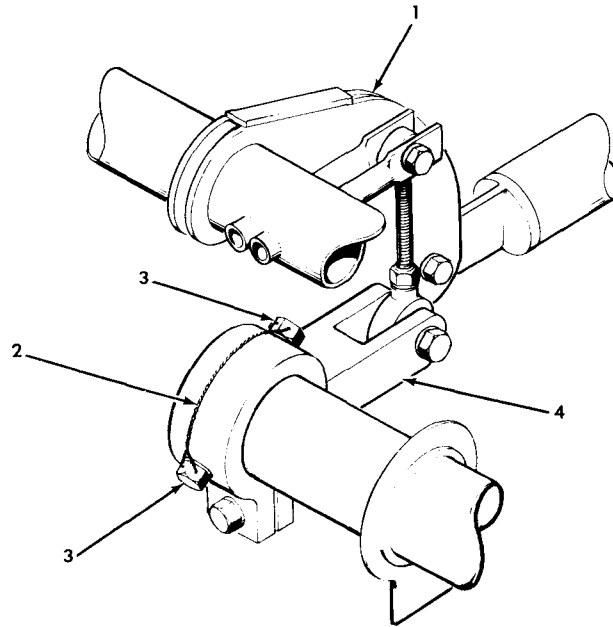

3521

1. Flap Torque Tube Horn
2. Safety Wire (AA5-0001 Thru AA5-0050 Only)
3. Special Drive Bolts
4. Flap Torque Tube Bellcrank

Flap Drive Assembly
Figure 204

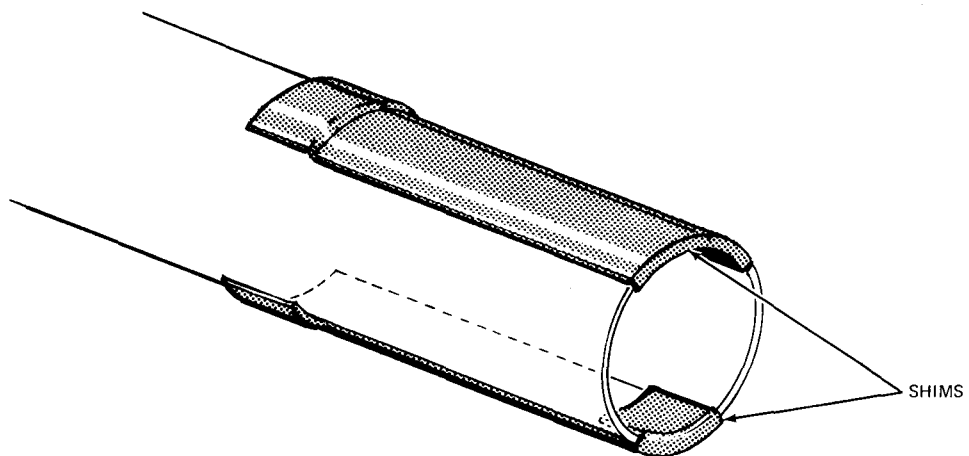

3522

Shim Installation
Figure 205

2. Wing Root Removal/Installation

A. Wing Root Removal (Support Brackets Attached to Root)

NOTE: If wing root is to be removed and installed with support brackets attached to root structure, follow procedures in A. and B. below.

NOTE: Numbers in parentheses refer to callouts in Figure 201.

- (1) Remove wing. (See Paragraph 1.A.)
- (2) Remove aft fuselage inner trim paneling. (Refer to Aft Fuselage Inner Trim Paneling Removal, Chapter 25.)
- (3) Remove the screws attaching interior upholstery side panels to fuselage.
- (4) Remove the screws (4) and washers (5) from inboard edge of the wing root (3).
- (5) From within the fuselage, remove the bolts (6), washers (7), and spacers (8), securing the support brackets (9 and 10) to the fuselage. Remove wing root with brackets attached.
- (6) Remove the seal (11).

B. Wing Root Installation (Support Brackets Attached to Root)

- (1) Place seal (11) in position between wing root and fuselage.
- (2) Align holes in support brackets (9 and 10) installed in the root and holes in the inboard edge of the wing root with holes in the fuselage side.
- (3) Install the bolts (6), washers (7), and spacers (8) to secure the support brackets with root attached to the fuselage side.
- (4) Apply Loctite to screw threads and install the screws (4) and washers (5) securing the inboard edge of the wing root to the fuselage side.
- (5) Install screws attaching interior upholstery side panels to fuselage.
- (6) Install aft fuselage inner trim paneling. (Refer to Aft Fuselage Inner Trim Paneling Removal, Chapter 25.)
- (7) Install wing. (See Wing Installation, Paragraph 1.D.)

C. Wing Root Removal (Support Brackets Remaining Attached to Fuselage)

- (1) Remove wing. (See Paragraph 1.A.)
- (2) Remove the screws (12) and washers (13) on the top and bottom surfaces of the wing root (3).
- (3) Remove the bolts (14) and washers (15) from the side face of the wing root.
- (4) Remove screws attaching interior upholstery side panels to fuselage.
- (5) Remove aft fuselage inner trim paneling. (Refer to Aft Fuselage Inner Trim Paneling Removal, Chapter 25.)
- (6) Remove the screws (4) and washers (5) from the inboard edge of the wing root and pull the wing root from the fuselage.
- (7) Remove the seal (11).

D. Wing Root Installation (Support Brackets Attached to Fuselage)

- (1) Place seal in position between wing root (3) and fuselage.
- (2) Align holes in wing root with holes in support brackets (9 and 10) and align holes in the inboard edge of the wing root with holes in the fuselage side.
- (3) Apply Loctite to screw threads and install screws (12) and washers (13) on the top and bottom surface of the wing root.
- (4) Install the bolts (14) and washers (15) to the side face of the wing root.
- (5) Apply Loctite to screw threads and install screws (4) and washers (5) to the inboard edge of the wing root.
- (6) Install wing. (See Paragraph 1.D.)
- (7) Install screws attaching interior upholstery side panels to fuselage.
- (8) Install aft fuselage inner trim paneling. (Refer to Aft Fuselage Inner Trim Paneling Installation, Chapter 25.)

3. Wing Tip Removal/Installation

A. Wing Tip Removal

NOTE: Numbers in parentheses refer to Figure 202.

- (1) Remove the screws (12) from the outboard edge of the outer wing panel.
- (2) With the aileron in the neutral or down position to clear the balance weight, carefully slide the wing tip (13) from the outer wing panel (14) until the navigation and strobe light wires come into view.
- (3) From inside the wing tip, disconnect the navigation and strobe light wires and pull the wing tip from the outer wing panel.

B. Wing Tip Installation

NOTE: Check condition and location of all clip nuts before wing tip installation.

- (1) Align wing tip (13) with outboard edge of the outer wing panel (14) and connect navigation and strobe light wires.

NOTE: Check for positive clearance of the aileron balance weight.

- (2) Secure wing tip to outer wing panel with screws (12).

4. Wing and Center Spar Repair

Enlarged or elongated mounting holes in the wing spar and center spar and the resulting deformation or wear in the shoulder bolts (1, Figure 202) may result in excessive play or rocking at the junction. The maximum allowable dimension on mounting holes in the wing and center spar at this location is 0.380 inch.

If either mounting hole exceeds the above dimension, the following repair is acceptable from a structural standpoint.

NOTE: Two methods of mounting the nut plate within the center spar have been employed. On aircraft AA5-0001 through AA5-0714 and aircraft AA5B-0001, the nut plate is mounted directly to the center spar. On aircraft AA5-0715 and subsequent, AA5B-0002 and subsequent, and AA5A-0001 and subsequent, the nut plate is mounted to a spacer assembly which is in turn mounted to the center spar.

A. Aircraft AA5-0001 through AA5-0714 and AA5B-0001

NOTE: If both sets of mounting holes in one wing are to be repaired, complete the repair on one set of mounting holes before beginning the other to maintain proper alignment.

- (1) Remove the wing and wing root. Refer to Paragraphs 1 and 2 above.
- (2) Remove the rivets and the nut plate from the wing inboard spar. Use rivets conforming to MS20426AD4 to plug the existing rivet holes.
- (3) Install the wing on the airplane and install the bolt in the remaining nut plate to ensure proper alignment.
- (4) Drill and ream the mounting holes in the wing and center spar to 0.4375/0.4395 inch. Remove the wing from the airplane.
- (5) Modify a spacer assembly, Part Number 5102342-501 as shown in Figure 206.
- (6) Using the modified spacer assembly as a template, match drill two 0.128/0.133 inch holes in the wing spar. Countersink 100° x 0.242 inch diameter.
- (7) Install the modified spacer assembly in the wing spar and secure with MS20426AD4-12 rivets.
- (8) Install the wing and wing root using AN7 or AN177 bolt of suitable length in the modified spacer assembly.

B. Aircraft AA5-0715 and subsequent, AA5B-0002 and subsequent, AA5A-0001 and subsequent

NOTE: If both sets of mounting holes in one wing are to be repaired, complete the repair on one set of mounting holes before beginning the other to maintain proper alignment.

- (1) Remove the wing and wing root. Refer to Paragraphs 1 and 2 above.
- (2) Remove the rivets and the spacer assembly containing the nut plate from the inboard spar.
- (3) Install the wing on the airplane and install the bolt in the remaining nut plate to ensure proper alignment.
- (4) Drill and ream the mounting holes in the wing and center spar to 0.4375/0.4395 inch. Remove the wing from the airplane.
- (5) Modify the spacer assembly as shown in Figure 206.
- (6) Install the modified spacer assembly in the wing spar and secure with MS20426AD4-12 rivets.
- (7) Install the wing using AN7 or AN177 bolt of suitable length in the modified spacer assembly.

5102342-501
SPACER ASSEMBLY

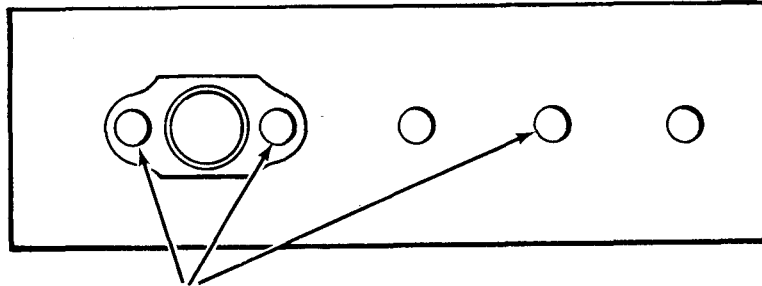

REMOVE RIVETS AND
NAS1031P5 NUT PLATE

INSTALL NAS1031P7 NUT PLATE

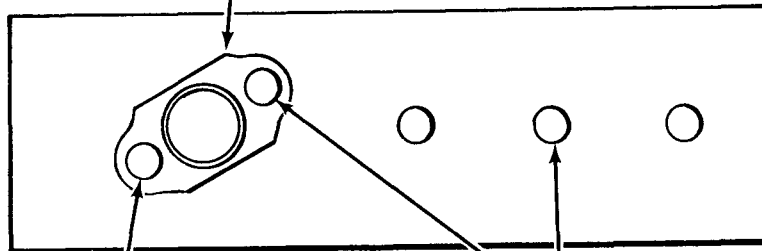

MS20426AD4-4
RIVET
(INSTALL FIRST)

MS20426AD4-7
RIVETS

NOTE: Rotate P7 nut plate approximately as shown to allow sufficient rivet edge clearance. Drill 0.128/0.133 holes. Counter-sink 100° x 0.242 diameter on the opposite side. Secure nut plate with rivet types indicated above.

Spacer Assembly Modification
Figure 206

**AA-5 SERIES
MAINTENANCE MANUAL**

CHAPTER 61

PROPELLER

TABLE OF CONTENTS

| <u>NUMBER</u> | | <u>PAGE</u> |
|----------------------|---------------------------------------|--------------------|
| 61-0 | PROPELLER | |
| | Description/Operation | 1 |
| | General | 1 |
| | AA-5 and AA-5A Propeller | 1 |
| | AA-5B Propeller | 1 |
| 61-1-1 | PROPELLER ASSEMBLY | |
| | Description/Operation | 1 |
| | General | 1 |
| | Maintenance Practices | 201 |
| | Servicing | 201 |
| | Propeller Removal/Installation | 201 |
| | Inspection/Check | 204 |
| | Cleaning/Painting | 206 |
| | Approved Repairs | 207 |

**AA-5 SERIES
MAINTENANCE MANUAL**

PROPELLER — DESCRIPTION/OPERATION

1. General

A. AA-5 and AA-5A Propeller

The AA-5 and AA-5A aircraft are equipped with a two blade, fixed-pitch, aluminum alloy propeller, manufactured by McCauley Accessory Division. Part numbers for the propeller are as follows: If an aluminum spacer is used, the part number is 1C172/BTM-7359. If a steel spacer is used, the part number is 1C172/SBTM-7359.

B. AA-5B Propeller

The AA-5B aircraft is equipped with a two blade, fixed-pitch, aluminum alloy propeller, manufactured by McCauley Accessory Division, the part number is 1A170/FFA 7563, 1A170/KFA 7563, or 1A170E/KFA 7563.

PROPELLER ASSEMBLY – DESCRIPTION/OPERATION

1. General

The propeller assembly consists of the propeller, spacer, the spinner, and attaching hardware. The spinner assembly consists of a formed aluminum spinner, an aluminum support bulkhead assembly to which it is secured by screws and washers.

CAUTION: DO NOT MOVE THE AIRCRAFT ON THE GROUND BY PUSHING ON THE SPINNER.

STORE THE AIRCRAFT WITH THE PROPELLER IN THE VERTICAL POSITION TO PREVENT WATER ACCUMULATION IN THE SPINNER AND SUBSEQUENTLY FREEZING IN COLD WEATHER.

DO NOT OPERATE THE ENGINE WITH ICE IN THE SPINNER.

**AA-5 SERIES
MAINTENANCE MANUAL**

PROPELLER ASSEMBLY – MAINTENANCE PRACTICES

1. Servicing

Keep the propeller clean and free from stains or foreign matter. Continued propeller care will aid in preventing corrosion, especially in coastal regions. Refer to paragraph 4, this section, for cleaning procedure and materials.

2. Propeller Removal/Installation

A. Propeller Removal - AA5-0001 and subsequent, AA5A-0001 through 0829, AA5B-0001 through 1047 (See Figure 201.) For Aircraft within these serial number sequences having Service Kit 143 installed refer to paragraph 2C below.

- (1) Remove screws (1) from spinner (2) and slide spinner forward off of propeller.
- (2) Remove forward bulkhead (3) and shims (4) from spinner.
- (3) Cut safety wire (5). Remove bolts (6) and washers (7).
- (4) Pull propeller (8) forward to remove from aircraft.

NOTE: When the propeller (8) is removed, the spacer (9) backplate assembly (10) and dowels (11) will remain attached to it.

CAUTION: WHEN REMOVING SPACER, ENSURE THAT PROPELLER IS SUPPORTED AS CLOSE TO BACKPLATE ASSEMBLY AS POSSIBLE. SUPPORTING IT NEAR THE TIPS MAY RESULT IN DAMAGE.

- (5) Place the propeller on two padded supports, with the spacer (9) down.
- (6) Use a soft metal 3/8-inch drift punch to drive the dowel pins (11) from the propeller (8).
- (7) Remove backplate assembly (10) from spacer (9).

B. Propeller Installation - AA5-0001 and subsequent, AA5A-0001 through 0829, AA5B-0001 through 1047 (See Figure 201.) For Aircraft within these serial number sequences having Service Kit 143 installed refer to paragraph 2D below.

- (1) Place backplate assembly (10) over dowel pins (11) in spacer (9).

NOTE: Propeller and spacer are matched during manufacturing. Align propeller serial No. stamped on spacer with No. 1 propeller blade for best balance. Propeller blade No. 1 can be identified by "#1" stamped on blade.

- (2) Place propeller (8) on backplate assembly (10) so that the dowel holes in the propeller (8) are aligned with the dowel pins (11). Ensure that the bolt holes in the propeller (8) are aligned with the dowel pins (11). Ensure that the propeller (8) and backplate (10) are aligned with the bolt holes in the spacer (9).
- (3) Place a padded wooden block on the propeller hub, and lightly tap the block with a hammer to seat the dowel pins in the propeller.

WARNING: ENSURE THAT THE MAGNETO SWITCH IS SET TO OFF AND THE MIXTURE IS SET TO IDLE CUTOFF PRIOR TO ROTATING THE CRANKSHAFT.

- (4) Rotate the engine crankshaft until the TC mark on the starter gear is aligned with the parting line on the engine crankcase.
- (5) On AA-5B aircraft, position the propeller by rotating the crankshaft until the top center (TC) mark on the starter gear and the crankcase parting flange or the index on the starter housing are aligned, then install propeller at the one and seven o'clock position.

On AA-5 and AA-5A aircraft position the propeller with the spacer against the engine, and the No. 1 blade of the propeller at the ten o'clock position. Ensure that the bolt holes in the spacer align with the bolt holes in the engine.

- (6) Install the six propeller bolts (6) and washers (7). Torque as follows: for AA-5 and AA-5A aircraft, 540 inch-pounds. For AA-5B aircraft, 750 ± 30 inch-pounds.
- (7) Safety wire bolts, (6), in pairs, with 0.041 inch minimum diameter safety wire (5).

AA-5 SERIES
MAINTENANCE MANUAL

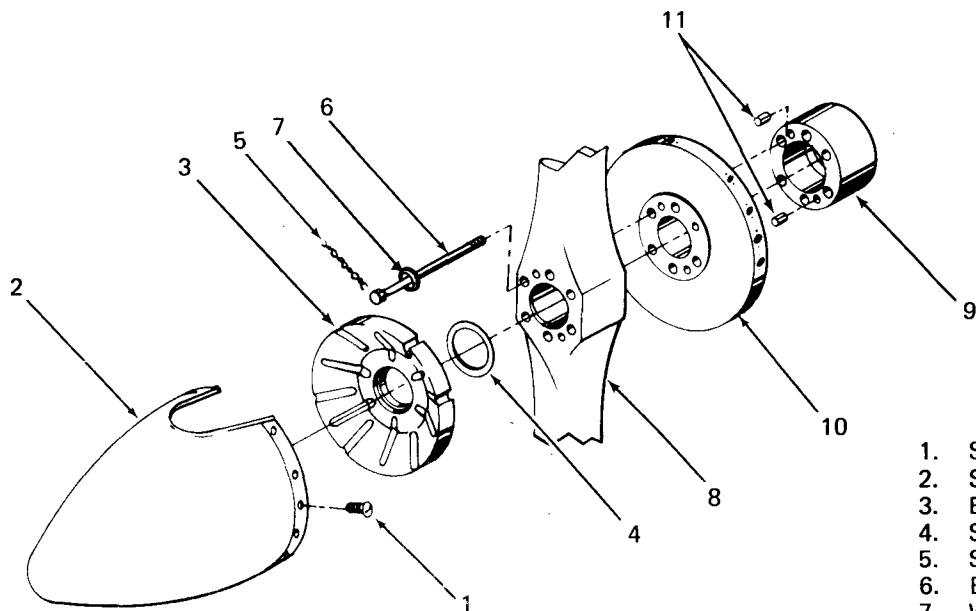

1. SCREW
2. SPINNER
3. BULKHEAD
4. SHIM
5. SAFETY WIRE
6. BOLT
7. WASHER
8. PROPELLER
9. SPACER
10. BACKPLATE ASSY.
11. DOWEL PIN

AA5-0001 AND SUBSEQUENT WITH OUT SERVICE KIT 143
AA5A-0001 THROUGH 0829 WITH OUT SERVICE KIT 143
AA5B-0001 THROUGH 1047 WITH OUT SERVICE KIT 143

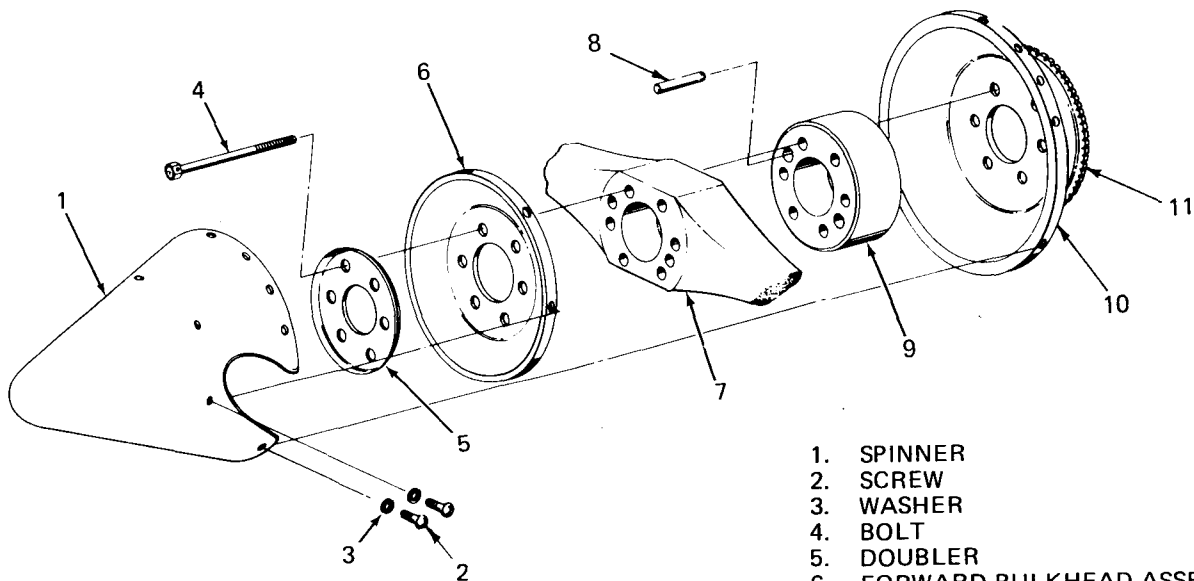

1. SPINNER
2. SCREW
3. WASHER
4. BOLT
5. DOUBLER
6. FORWARD BULKHEAD ASSEMBLY
7. PROPELLER
8. DOWEL PIN
9. SPACER
10. AFT BULKHEAD ASSEMBLY
11. STARTER RING GEAR

AA5A-0830 AND SUBSEQUENT
AA5B-1048 AND SUBSEQUENT
AA5-0001 AND SUBSEQUENT
WITH SERVICE KIT 143
AA5A-0001 THROUGH 0829
WITH SERVICE KIT 143
AA5B-0001 THROUGH 1047
WITH SERVICE KIT 143

Propeller Removal/Installation
Figure 201

**AA-5 SERIES
MAINTENANCE MANUAL**

- (8) Place shims (4) on bulkhead (3) and insert rear of bulkhead (3) into propeller (8). Install spinner (2) and check alignment of screw holes in spinner (2) and backplate assembly (10). Add or remove shims (up to a maximum of 6) to obtain a preloading of 0.10 inch. Proper preloading occurs when the holes in the spinner are approximately 1/2 hole-width forward of those in the backplate assembly.
- (9) Push spinner (2) until holes align, then secure spinner (2) to backplate (10) with screws (1). Tighten screws in sequence listed in Figure 202.

C. Propeller Removal - AA5A-0830 and subsequent, AA5B-1048 and subsequent (See Figure 201.) Also for Aircraft within the following serial number sequences having Service Kit 143 installed: AA5-0001 and subsequent, AA5A-0001 through 0829, AA5B-0001 through 1047.

- (1) Prepare a suitable padded support for the propeller. The propeller should be supported as close to the hub as possible.

CAUTION: SUPPORTING THE PROPELLER NEAR THE TIPS MAY RESULT IN DAMAGE.

- (2) Prepare the airplane for safe maintenance. Place the MASTER and MAGNETO switches in the OFF Position. Make sure the airplane is grounded. Set the mixture control to the idle cutoff position.

CAUTION: WHEN WORKING WITH THE PROPELLER, ALWAYS TREAT IT AS THOUGH THE MAGNETO WERE ON. STAND CLEAR IF IT IS NECESSARY TO ROTATE THE PROPELLER FOR ANY REASON. A FAULTY GROUND ON EITHER MAGNETO CAN CAUSE THE ENGINE TO FIRE.

- (3) Remove screws (2) and washers (3) securing spinner (1) to forward bulkhead assembly (6) and aft bulkhead assembly (10). Remove spinner (1) by sliding forward off of propeller.
- (4) Remove safety wire from bolts (4). Provide support for propeller (7) and remove bolts (4) doubler (5) and forward bulkhead (6). Move propeller to padded supports with spacer (9) down.
- (5) Using a fiber or soft metal 3/8 inch drift punch, drive the dowel pins (8) from the propeller (7). Remove spacer (9), and aft bulkhead assembly (10).

D. Propeller Installation - AA5A-0830 and subsequent, AA5B-1048 and subsequent (See Figure 201.) Also for aircraft within the following serial number sequences having Service Kit 143 installed: AA5-0001 and subsequent, AA5A-0001 through 0829, AA5B-0001 through 1047.

NOTE: Propeller (7) and spacers (9) are provided by the manufacture in matched pairs identified with the same serial number and should not be intermixed. For best balance, align the serial number on the spacer with the propeller blade stamped #1.

- (1) Install the dowel pins (8) in the dowel holes in the spacer (9). Position the propeller (7) so that the #1 blade corresponds to the position of the serial number on the spacer and start the dowel pins into the dowel holes in the propeller.
- (2) With the propeller secure on the padded support, place a padded wooden block on the propeller hub. Lightly tap the block with a hammer to seat the dowel pins in the propeller.
- (3) Install aft bulkhead assembly (10) on starter ring gear (11) and use a temporary method of securing the bulkhead in place. (One temporary method is to tape the bulkhead to the nose cowl.)

CAUTION: THE AFT BULKHEAD CAN BE DAMAGED IF NOT HELD SECURELY IN PLACE DURING PROPELLER INSTALLATION. REMOVE TEMPORARY SECURING MATERIAL AFTER PROPELLER MOUNT BOLTS ARE TORQUED.

- (4) Position Forward bulkhead assembly (6) and doubler (5) on propeller (7) and insert propeller mount bolts (4) through the doubler, bulkhead, propeller, and spacer. Install this assembly on the starter ring gear (11).

NOTE: Do not use any washers on bolts (4).

- (5) Install propeller mount bolts (4) into starter ring gear (11) and torque the bolts to the following values:

| | |
|------------|---|
| AA-5/AA-5A | 45 LB.FT./40 LB.FT. (540 LB.IN./480 LB.IN.) |
| AA-5B | 65 LB.FT./55 LB.FT. (780 LB.IN./660 LB.IN.) |

Safety wire propeller mount bolts in pairs.

**AA-5 SERIES
MAINTENANCE MANUAL**

- (6) Install the spinner (1) over the propeller (7) and align with holes in forward bulkhead assembly (6) and aft bulkhead assembly (10). Install washers (3) and screws (2).

NOTE: Use only washers conforming to Federal Specification NAS1515J3L. Do not use metal washers of any kind.

NOTE: Install all screws and washers before beginning the tightening sequence.

- (7) Tighten the screws to standard torque (Chapter 91) using the sequence shown in Figure 202. Repeat the sequence to correct any torque loss due to compression of the nonmetallic washers.

3. Inspection/Check

A. Propeller Inspection

- (1) Include the propeller in every preflight inspection. The propeller should receive special attention for condition during 50 and 100 hour inspections. Visually inspect the entire propeller for damage and defects. Any necessary repairs should be made before further flight, and should strictly adhere to AC43.13-1, "Aircraft Inspection and Repair Manual," and service publications of the propeller manufacturer.
- (2) Remove the spinner at each 100 hour inspection. (Refer to paragraph 3B, below, for spinner inspection) After inspection, necessary repairs and reinstallation of spinner, check the spinner run-out. Maximum allowable run-out measured at the tip of the spinner is:

AA5-0001 and subsequent without service kit 143 (0.010 inch)

AA5-0001 and subsequent with service kit 143 (0.025 inch)

AA5A-0001 through 0829 without service kit 143 (0.010 inch)

AA5A-0001 through 0829 with service kit 143 (0.025 inch)

AA5B-0001 through 1047 without service kit 143 (0.010 inch)

AA5B-0001 through 1047 with service kit 143 (0.025 inch)

AA5A-0830 and subsequent (0.025 inch)

AA5B-1048 and subsequent (0.025 inch)

- (3) Some of the types of damage and defects which may be observed are defined as follows:

Burr — A small, thin section of metal extending beyond a regular surface, usually located at a corner or on the edge of a bore or hole.

Corrosion — Loss of metal from the surface by chemical or electrochemical action. The corrosion products generally are easily removed by mechanical means. Iron rust is an example of corrosion.

Crack — A physical separation of two adjacent portions of metal, evidenced by a fine or thin line across the surface, caused by excessive stress at that point. It may extend inward from the surface, from a few thousandths of an inch to completely through the section thickness.

Cut — Loss of metal, usually to an appreciable depth over a relatively long and narrow area, by mechanical means, as would occur with the use of a saw blade, chisel, or sharp-edged stone striking a glancing blow.

Dent — Indentation in a metal surface produced by an object striking with force. The surface surrounding the indentation will usually be slightly upset.

Erosion — Loss of metal from the surface by mechanical action of foreign objects, such as grit or fine sand. The eroded area will be rough and may be lined in the direction in which the foreign material moved relative to the surface.

Fretting — Breakdown or deterioration of metal surface by vibratory or "chattering" action. Usually no loss of metal or cracking of surface but generally showing similar appearance.

Gouge — Grooves in, or breakdown of, metal surface from contact of foreign material under heavy pressure. Usually indicates metal loss but may be largely displacement of material.

Inclusion — Presence of foreign or extraneous material wholly within a portion of metal. Such material is introduced during the manufacture of rod, bar, or tubing by rolling or forging.

Nick — Local break or notch on edge. Usually displacement of metal rather than loss.

Pitting — Sharp, localized breakdown (small, deep cavity) of metal surface, usually with defined edges.

Scratch — Slight tear or break in metal surface from light, momentary contact by foreign material.

Score — Deeper (than scratch) tear or break in metal surface from contact under pressure. May show discoloration from temperature produced by friction.

AA-5 SERIES
MAINTENANCE MANUAL

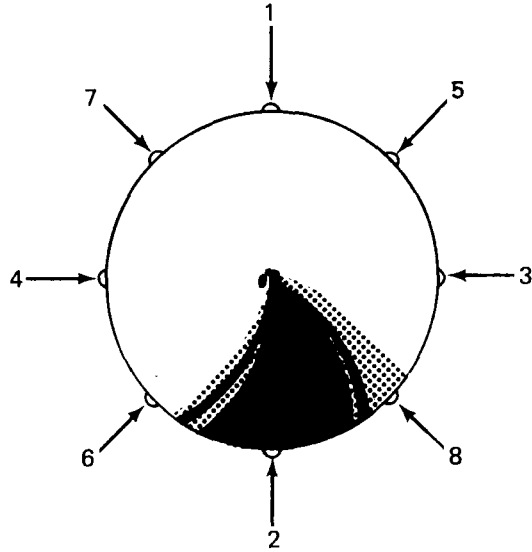

AA5-0001 AND SUBSEQUENT WITHOUT SERVICE KIT 143
AA5A-0001 THROUGH 0829 WITHOUT SERVICE KIT 143
AA5B-0001 THROUGH 1047 WITHOUT SERVICE KIT 143

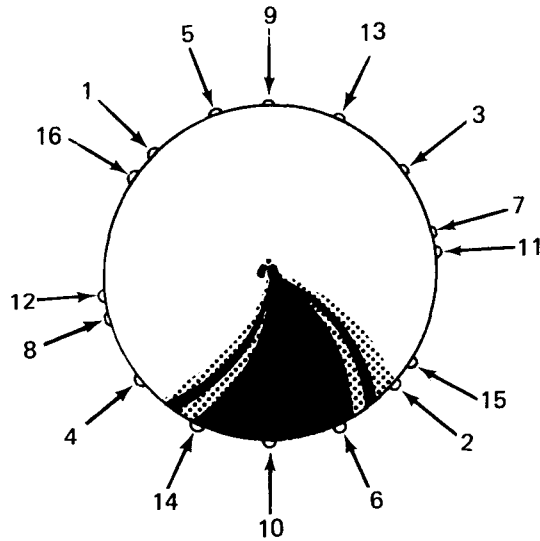

AA5A-0830 AND SUBSEQUENT
AA5B-1048 AND SUBSEQUENT
AA5-0001 AND SUBSEQUENT WITH SERVICE KIT 143
AA5A-0001 THROUGH 0829 WITH SERVICE KIT 143
AA5B-0001 THROUGH 1047 WITH SERVICE KIT 143

Spinner Screw Tightening Sequence
Figure 202

**AA-5 SERIES
MAINTENANCE MANUAL**

Stain — A change in color, locally, causing a noticeably different appearance from the surrounding area.

- (4) Visually inspect all parts for damage or defects. Check all bolt threads for rough edges and irregularities. Check that surface finish (anodizing or plating) is not broken, chipped or peeled (if peeled, look for corrosion). Staining and slight surface markings (not perceptible to fingernail) are normal and not alone cause for rejection or replacement.
- (5) If scratches or suspected cracks are found, determine their extent by use of the penetrant inspection method, Military Specification MIL-L-6866. The fluorescent method. "Zyglo" (Magnaflux Corp., Chicago, Ill.), is preferred; however, a non-fluorescent method, "Dy-check" (Turco Products Co., Los Angeles, Calif.), may also be used.

B. Spinner Inspection

- (1) Include the spinner in every preflight inspection.
- (2) Inspect for loose, damaged, or missing screws and washers. Visually inspect for evidence of corrosion. Tighten or replace mounting hardware as required.
- (3) Inspect for dents, scoring, nicks and scratches.
- (4) Inspect the flanged area around the propeller cut out for nicks and cracks.
- (5) Remove the spinner at each 100 hour inspection. Visually inspect the bulkheads and doubler for security of mounting, cracks, missing or damaged plate nuts. Inspect the spinner items listed in sub-paragraphs (2), (3) and (4) above. On early model aircraft without Service Kit 143 (see figure 201), inspect the centering bulkhead for cracks and evidence of rotation which indicates an improper preload.
- (6) Upon Completion of 100 hour inspection, necessary repairs and spinner reinstallation, check spinner run-out in accordance with paragraph 3A(2) above.

4. Cleaning/Painting

A. Propeller Cleaning/Painting

WARNING: USE SOLVENT IN A WELL VENTILATED AREA. DO NOT BREATHE FUMES. KEEP AWAY FROM FLAMES.

CAUTION: DO NOT USE METAL TOOLS OR BRUSHES ON PROPELLER. DO NOT USE HARD BRISTLE BRUSHES ON PROPELLER.

- (1) Prepare a solution consisting of one part Lubricating Oil, Military Specification MIL-L-6082, Grade 1065, and two parts Solvent, Federal Specification P-S-661. Use this solution and a soft cloth to remove grease, dirt, and stains from the propeller. A soft bristle brush may be used on stubborn deposits, but do not use hard bristles, metal brushes, or metal tools on the propeller.
- (2) After cleaning, wipe the excess cleaning solution from the propeller and allow to air dry, or use low-pressure shop air to remove the excess solvent.
- (3) Refer to manufacturer's data for propeller painting instructions.

**AA-5 SERIES
MAINTENANCE MANUAL**

B. Spinner Cleaning/Painting

- (1) Refer to Chapter 20 for spinner cleaning and painting procedures.

5. Approved Repairs

A. Propeller Repair

- (1) Repair the propeller in accordance with AC 43.13-1, Aircraft Inspection and Repair Manual or manual and bulletins published by the propeller manufacturer.

B. Spinner Assembly Repair

- (1) **Spinner** and components repair consists of replacement of missing or loose attachment hardware (screws **and nutplates**). If the spinner is warped or dented it should be replaced.
- (2) **Polish out** nicks, scratches, and scoring.
- (3) Determine the extent of cracks or suspected areas as described in paragraph 3A(5) above. Cracks may be repaired by welding. Do not attempt repair if crack extends into a mounting hole.

AA-5 SERIES
MAINTENANCE MANUAL

CHAPTER 71

POWER PLANT

TABLE OF CONTENTS

| <u>NUMBER</u> | | <u>PAGE</u> |
|---------------|--|-------------|
| 71-0 | POWER PLANT | |
| | Description/Operation | 1 |
| | General | 1 |
| | Engine Data | 1 |
| | Engine Operation | 1 |
| | Troubleshooting the Power Plant | 101 |
| | Maintenance Practices | 201 |
| | General | 201 |
| | Cleaning Power Plant | 201 |
| | Power Plant Removal/Installation | 201 |
| 71-1-1 | POWER PLANT COWLING | |
| | Description/Operation | 1 |
| | General | 1 |
| | Maintenance Practices | 201 |
| | Removal/Installation AA-5 Serial No. 0001 through 0640 | 201 |
| | Removal/Installation AA-5 Serial No. 0641 and Subsequent, AA-5A and AA-5B | 201 |
| 71-2-1 | ENGINE MOUNT | |
| | Description | 1 |
| | General | 1 |
| | Maintenance Practices | 201 |
| | Removal/Installation | 201 |
| 71-6-1 | AIR INTAKES | |
| | Description/Operation | 1 |
| | General | 1 |

AA-5 SERIES
MAINTENANCE MANUAL

| <u>NUMBER</u> | | <u>PAGE</u> |
|---------------|-----------------------|-------------|
| 71-6-2 | ENGINE BAFFLES | |
| | Description/Operation | 1 |
| | General | 1 |
| | Maintenance Practices | 201 |
| | Removal/Installation | 201 |
| 71-7-1 | ENGINE DRAINS | |
| | Description | 1 |
| | General | 1 |

POWER PLANT - DESCRIPTION/OPERATION

1. General

The AA-5 and AA-5A are powered by a 150 H. P. Lycoming, four-cylinder, horizontally opposed, air-cooled engine. The engine turns a McCauley fixed pitch propeller, model 1C172/BTM-7359 or 1C172/SBTM-7359. The AA-5B is powered by a 180 H. P. Lycoming, four-cylinder, horizontally opposed, air cooled engine. The engine turns a McCauley fixed pitch propeller, model 1A170/FAA-7563.

The power plant is enclosed by a three-segment cowl assembly consisting of an upper, lower, and forward cowl assembly.

The engine is attached to the engine mount assembly at four places using vibration isolator type shock mounts. After complete engine build-up the power plant is attached to the fuselage at the four engine mount support locations.

The engine is cooled by ram air pressure that is forced over and around the cylinders by the use of baffles. The air is then exhausted to the atmosphere through exit ducts located in the bottom of the lower cowl.

2. Engine Data

| | <u>AA-5 and AA-5A</u> | <u>AA-5B</u> |
|---|-----------------------|-----------------|
| Engine | 0-320-E2G | 0-360-A4K |
| Rated horsepower | 150 | 180 |
| Rated speed,RPM | 2700 | 2700 |
| Bore, inches | 5.125 | 5.125 |
| Stroke, inches | 3.875 | 4.375 |
| Displacement, cubic inches | 319.8 | 361.0 |
| Compression Ratio | 7.0:1 | 8.50:1 |
| Firing order | 1-3-2-4 | 1-3-2-4 |
| Spark occurs degrees BTC | 25 | 25 |
| Spark plug gap | 0.017 to 0.021* | 0.017 to 0.021* |
| Valve rocker clearance (hydraulic tappets collapsed) | 0.028-0.080 | 0.028-0.080 |
| Propeller drive ratio | 1:1 | 1:1 |
| Propeller drive rotation (viewed from rear) | Clockwise | Clockwise |

*See latest revision of Lycoming Service Instruction Number 1042 for gap on specific plug being used.

3. Engine Operation

Refer to Avco Lycoming Operator's Manual, Avco Lycoming Service Instructions, and the Aircraft Owner's Manual or Pilot's Operating Handbook for proper operation of the engine.

AA-5 SERIES
MAINTENANCE MANUAL

POWER PLANT - TROUBLESHOOTING

1. Troubleshooting the Power Plant

| TROUBLE | PROBABLE CAUSE | REMEDY |
|----------------------------|--------------------------------------|---|
| Engine fails to start | Lack of fuel | Open fuel selector valve. Service fuel tanks. Push mixture control to full rich position. |
| | Flooded, or over-primed | Open the throttle and unload engine by cranking. |
| | Underprimed | Prime with two to three strokes. |
| | Incorrect throttle setting | Open throttle approximately 1/4 inch. |
| | Defective spark plugs | Clean and regap, or replace. |
| | Dead or weak battery | Recharge or replace. |
| | Defective ignition wire | Check with electric tester, and replace any defective wires. |
| | Water in carburetor | Drain carburetor and lines. |
| | Internal failure | Check oil sump for metal particles. If found, complete overhaul is indicated. |
| Engine not idling properly | Incorrect carburetor idle adjustment | Adjust throttle stop to obtain correct idle. |
| | Idle mixture | Adjust mixture. |
| | Open primer | Lock primer in closed position. |
| | Leak in the induction system | Tighten all connections and replace defective parts. |
| | Uneven cylinder compression | Check condition of rings and valve seats and then check cylinder compression. |
| | Insufficient fuel pressure | Check fuel pumps and filters. |
| | Faulty ignition system | Check ignition leads, plugs and magnetos. |

AA-5 SERIES
MAINTENANCE MANUAL

| TROUBLE | PROBABLE CAUSE | REMEDY |
|---|--|--|
| Low power and uneven running | Mixture too rich | Readjustment of carburetor by authorized personnel. |
| | Mixture too lean | Readjustment of carburetor by authorized personnel. |
| | Leaks in induction system | Tighten all connections and replace defective parts. |
| | Defective spark plugs | Clean and gap or replace spark plugs. |
| | Defective ignition wire | Replace wire. |
| | Magnetos not properly timed | Check for proper timing and synchronization. |
| | Defective spark plug terminal connectors | Replace connectors on spark plug wire. |
| | Improper grade of fuel | Empty tank and fill with proper grade fuel. |
| Failure of engine to develop full power | Throttle not properly adjusted | Adjust throttle lever. |
| | Leak in the induction system | Tighten all connections and replace defective parts. |
| | Dirty air filter | Clean or replace filter. |
| | Restriction in air scoop | Remove restriction. |
| | Improper grade of fuel | Empty tank and fill with proper grade fuel. |
| | Faulty ignition system | Check ignition leads, plugs and magnetos. |
| Rough running engine | Lead deposit on spark plugs | Clean and regap or replace spark plugs. |
| | Unbalanced propeller | Remove propeller and check for balance. |
| | Worn mounting bushings | Install new mounting bushings. |
| | Uneven compression | Check compression. |
| | Magneto not properly timed | Check magneto timing (Refer to Chapter 74). |

AA-5 SERIES
MAINTENANCE MANUAL

| TROUBLE | PROBABLE CAUSE | REMEDY |
|---------------------------|--|---|
| Low oil pressure | Insufficient oil | Check oil supply and fill as recommended. |
| | Defective pressure gauge | Replace gauge. |
| | Dirty oil strainer | Remove and clean oil strainer. |
| | Air or dirt in relief valve | Remove and clean oil pressure relief valve. |
| | Leak in pressure or suction lines | Check gasket between accessory housing and crankcase. |
| | Stoppage in oil pump intake passage | Check line for obstruction and clean strainer. |
| | High oil temperature | See "High oil temperature" in "Trouble" column. |
| High oil temperature | Insufficient oil supply | Check oil supply and fill as recommended. |
| | Insufficient cooling air | Check cowl inlet and outlet for obstructions. Check baffles. |
| | Low grade of oil | Replace with oil conforming to specifications. (Refer to Chapter 12) |
| | Clogged oil cooler, lines or strainers | Remove and clean oil cooler, lines, and strainers. |
| | Defective gauge | Replace gauge. |
| | Defective probe | Replace probe. |
| | Excessive blow by | Usually caused by worn or stuck rings. Complete overhaul required. |
| | Bearing failure | Examine sump for metal particles. If found, complete overhaul required. |
| Excessive oil consumption | Bearing failure | Examine sump for metal particles. If found, complete overhaul required. |
| | Worn piston rings | Install new rings. |
| | Incorrect installation of piston rings | Install new rings. |

AA-5 SERIES
MAINTENANCE MANUAL

| TROUBLE | PROBABLE CAUSE | REMEDY |
|---------------------------|--|---|
| | Low grade of oil | Replace with proper grade of oil. |
| | External leakage | Check engine carefully for leaking gaskets and "O" rings. |
| | Failure of rings to seat (new nitrided cylinders) | Use mineral base oil, climb to cruise altitude at full power and operate above 75% cruise power setting until oil consumption stabilizes. |
| Engine does not stop | Mixture control not correctly adjusted | Adjust mixture control. |
| | Faulty ignition system | Check ground wires. |
| Cold weather difficulties | Cold oil | Heat oil. |
| | Weak battery | Recharge or replace. |
| | High oil pressure | In extreme cold weather, readings up to approximately 100 psi do not necessarily indicate malfunctioning. |
| | Overpriming | Open throttle, put mixture control in idle cut-off position. Crank engine until it starts. Immediately return mixture control to full rich position and close throttle as required. |

POWER PLANT - MAINTENANCE PRACTICES

1. General

Prior to performing maintenance on the power plant, ensure that all safety precautions such as switches in OFF position, fire extinguishers available, and NO SMOKING rules are enforced. The complete power plant should be inspected for cleanliness and general condition. More detailed and up-to-date maintenance information can be obtained from the Avco Lycoming Operator's Manual, Service Letters, Bulletins, and Service Instructions.

2. Cleaning Power Plant

WARNING: USE SOLVENTS IN A WELL VENTILATED AREA. AVOID BREATHING FUMES.
KEEP AWAY FROM FLAMES.

Cleaning of the power plant can be accomplished with a suitable solvent and drying thoroughly. (Standard Solvent or equivalent)

NOTE: Use extreme care to prevent solvent entering the magnetos, alternators, starter, vacuum pump, and openings in the engine. Keep the amount of solvent contacting wiring to a minimum.

3. Removal/Installation of Power Plant

A. Remove Power Plant

CAUTION: PRIOR TO REMOVAL OF THE ENGINE, PLACE A SUPPORT UNDER THE TAIL OF THE AIRCRAFT TO PREVENT DAMAGE TO THE EMPENNAGE. TAG OR LABEL ALL WIRING AND CABLES PRIOR TO REMOVAL OF THE ENGINE FOR REFERENCE ON INSTALLATION.

- (1) Remove the propeller and spinner (refer to Chapter 61).
- (2) Remove the cowling (refer to 71-1-1).
- (3) Disconnect the throttle, mixture, and carburetor heat controls.
- (4) Disconnect the fuel and oil pressure lines.
- (5) Disconnect the main fuel line at the inlet to the engine-driven fuel pump.
- (6) Disconnect the tachometer cable.
- (7) Disconnect the vacuum pump hose at the pump.
- (8) Disconnect the fuel primer lines.
- (9) Disconnect bonding from engine.
- (10) Disconnect all wiring from the engine.
- (11) Disconnect spark plug leads and lead clamps from engine.
- (12) Disconnect the heater duct at the muffler.
- (13) Attach a suitable lifting device to engine and remove the engine mounting bolts.

B. Install Power Plant

NOTE: Inspect the engine rubber mounting bushings for wear and deterioration. Replace as required.

- (1) Position the engine to the engine mount and install the mounting bolts. Torque mounting bolts to 450-500 inch-pounds.
- (2) Connect the heater duct to the muffler.
- (3) Connect all wiring to the engine.
- (4) Connect the fuel primer lines.
- (5) Connect the vacuum pump hose at the pump.
- (6) Connect the tachometer cable.
- (7) Connect the main fuel line at the inlet to the engine-driven fuel pump.
- (8) Connect the fuel and oil pressure lines.
- (9) Connect the throttle, mixture, and carburetor heat controls.
- (10) Connect bonding at top of engine.
- (11) Connect all spark plug leads and lead clamps.

NOTE: Refer to Chapter 73 for proper installation of the carburetor throttle control.

NOTE: Maintain a minimum 4-1/2 inches bend radius on all carburetor controls.

- (12) Install the cowling (refer to 71-1-1).
- (13) Install the propeller (refer to Chapter 61).

POWER PLANT COWLING - DESCRIPTION/OPERATION

1. General

The power plant is enclosed by a three-piece cowl assembly. The upper cowl assembly is located above the engine between the fuselage and forward cowl. The upper cowl is hinged in the center and latched to the lower cowl on each side. The upper cowl can be raised to gain access to the engine for inspection, service, or minor repair. The lower cowl assembly encloses the lower engine components and must be removed to gain access to the carburetor, exhaust system, air induction system and other lower engine components. The forward cowl covers the front of the engine and encloses the starter, flywheel, and alternator. The landing light is mounted in the forward cowl.

POWER PLANT COWLING – MAINTENANCE PRACTICES

1. Removal/Installation of Cowling AA-5 Serial No. 0001 through 0640

A. Remove Cowling (See Figure 201.)

- (1) Unfasten the latches (1) on each side of the cowl.
- (2) Remove screws (2) and lift off the upper cowl assembly (3).
- (3) Remove the screws (4 and 5) and washers (6).
- (4) Remove the lower cowl assembly (7).
- (5) Remove the propeller spinner, propeller, and spacer (refer to Chapter 61).
- (6) Disconnect landing light wires and remove forward cowl assembly (8).

NOTE: For removal, installation, and adjustment of the landing light assembly, refer to Chapter 33.

B. Install Cowling

CAUTION: WHEN ADJUSTING COWL LATCHES AT INSTALLATION, PROVIDE ONLY ENOUGH TENSION TO HOLD UPPER COWL SECURELY. OVER-TIGHTENING WILL CREATE EXCESSIVE STRESS AND CAUSE CRACKING OF COWL SKIN IN THE LATCH AREA.

- (1) Position forward cowl assembly (8) on front of engine and connect landing light wires.
- (2) Install spacer, propeller, and propeller spinner (refer to Chapter 61).
- (3) Position lower cowl assembly (7) in place on engine and install washers (6) and screws (4 and 5).
- (4) Position upper cowl assembly (3) in place on engine and install screws (2).
- (5) Fasten latches (1) on each side of the cowl.

2. Removal/Installation of Cowling AA-5 Serial No. 0641 and Subsequent, AA-5A and AA-5B

A. Remove Cowling (See Figure 202.)

- (1) Unfasten latches (1) on each side of the lower cowl.
- (2) Remove nuts (2), bolts (3), and washers (4) and lift off the upper cowl assembly (5).
- (3) Remove screws (6, 7, and 8) and strut fairing attach screws, and remove lower cowl assembly (9).

NOTE: Screws (7) that attach the induction system to the cowl are only used on aircraft AA-5, Serial No. 0641 and subsequent and on AA-5A.

- (4) Remove propeller spinner, propeller, and spacer (refer to Chapter 61).
- (5) Disconnect landing light wires and remove forward cowl assembly (10).

NOTE: For removal of the landing light assembly, refer to Chapter 33.

AA-5 SERIES
MAINTENANCE MANUAL

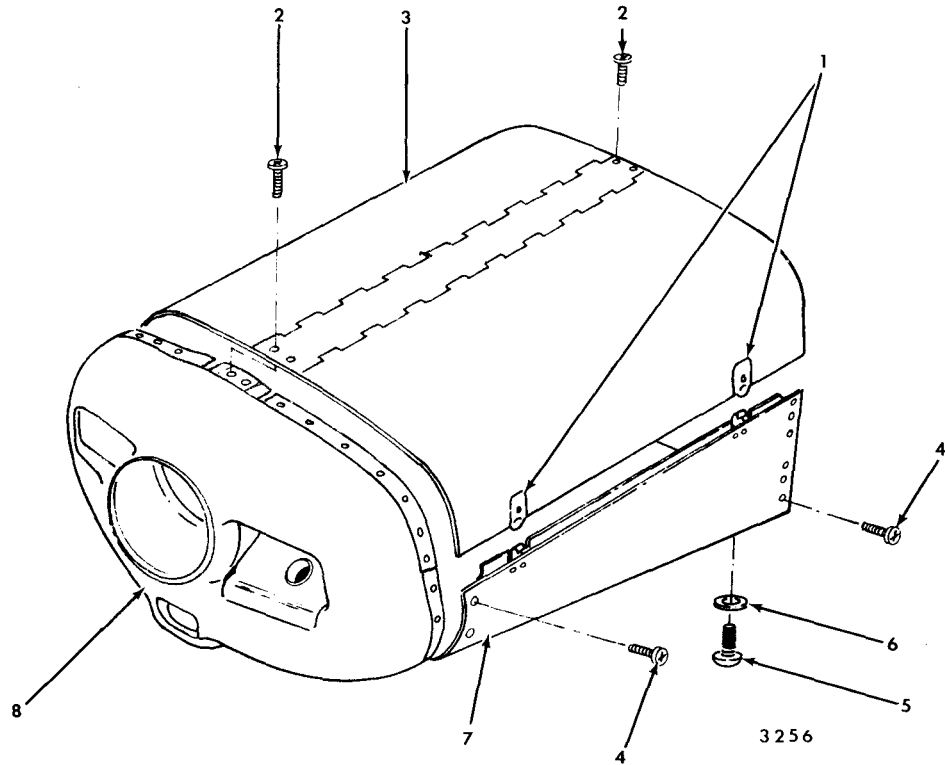

- | | |
|---------------------|-----------------------|
| 1. Cowl Latch | 5. Screw |
| 2. Screw | 6. Washer |
| 3. Upper Cowl Ass'y | 7. Lower Cowl Ass'y |
| 4. Screw | 8. Forward Cowl Ass'y |

Cowl Assembly - AA-5 Serial No. 0001 thru 0640
Figure 201

**AA-5 SERIES
MAINTENANCE MANUAL**

B. Install Cowling

NOTE: Adjust latch pin (11) lengths for snug fit of upper cowl at front and rear edges. Back off, if required, so that each latch requires no more than a 50 pound push for engagement. Latch pin must be rotated so that notch is aligned with clevis pin (12) for complete engagement. Measure latch position outside/inside cowl contour with cowl closed and open. Latch position when open must be 0.030 inch minimum outside of latch position when closed to ensure complete pin engagement.

NOTE: Coat lower 2.00 inches of latch pin (11) and inside diameter of guide bushing (13) with lubricant, McLube 1708, by McGee Chemicals Company, Inc.

(1) Position forward cowl assembly (10) on front of engine and connect landing light wires.

NOTE: For installation and adjustment of the landing light assembly, refer to Chapter 33.

(2) Install spacer, propeller, and propeller spinner (refer to Chapter 61).

(3) Position lower cowl assembly (9) in place on engine and install screws (6, 7, and 8) and strut fairing attach screws.

NOTE: Screws (7) that attach the induction system to the cowl are only used on aircraft AA-5 Serial No. 0641 and subsequent and on AA-5A.

(4) Position upper cowl assembly (5) in place on engine and install bolts (3), washers (4), and nuts (2).

(5) Fasten latches (1) on each side of lower cowl.

AA-5 SERIES
MAINTENANCE MANUAL

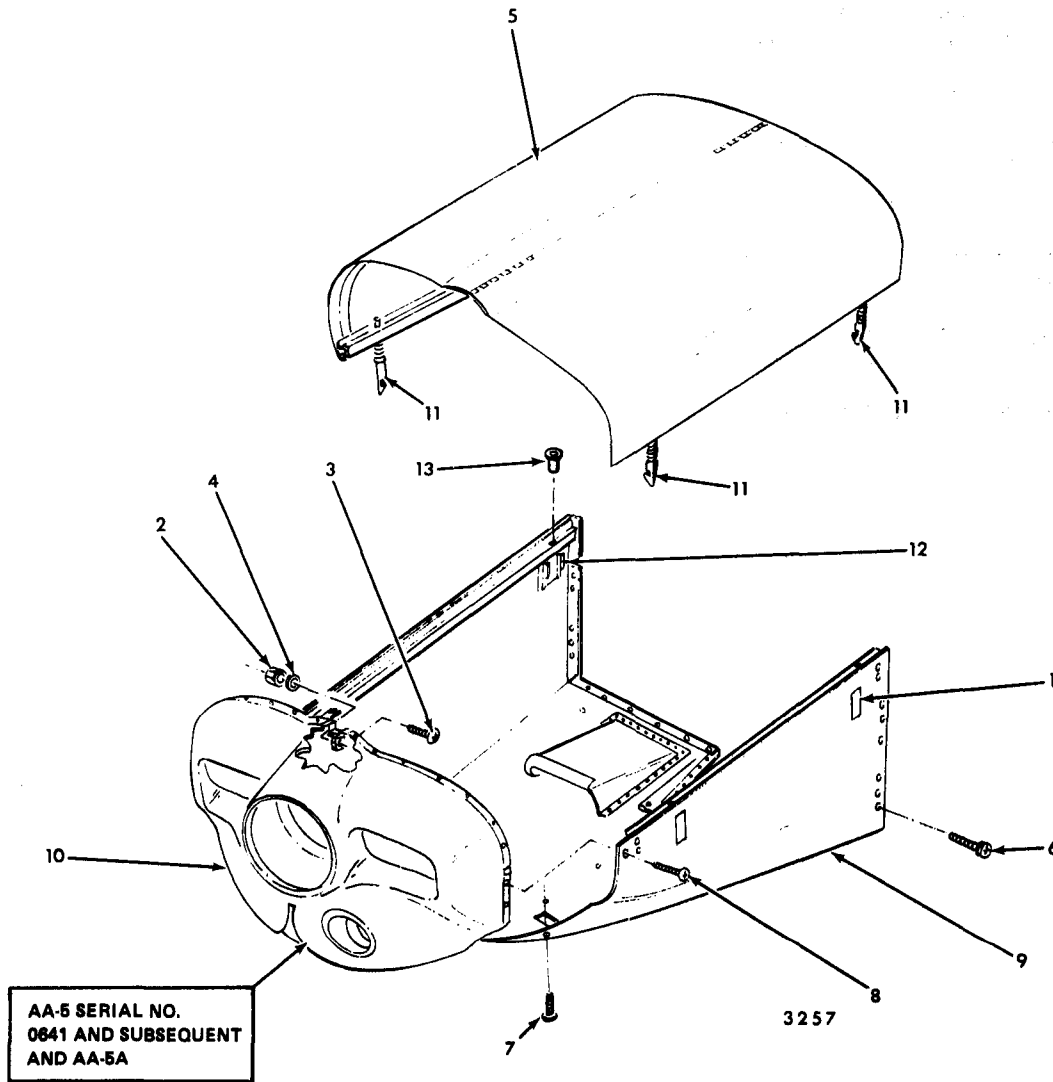

- | | | |
|---------------------|------------------------|-------------------|
| 1. Latch | 6. Screw | 11. Latch Pin |
| 2. Nut | 7. Screw | 12. Clevis Pin |
| 3. Bolt | 8. Screw | 13. Guide Bushing |
| 4. Washer | 9. Lower Cowl Ass'y | |
| 5. Upper Cowl Ass'y | 10. Forward Cowl Ass'y | |

Cowl Assembly - AA-5 Serial No. 0641 and Subsequent, AA-5A, and AA-5B
Figure 202

**AA-5 SERIES
MAINTENANCE MANUAL**

ENGINE MOUNT - DESCRIPTION

1. General

The engine mount is composed of sections of tubing, formed and welded together. The purpose of the engine mount is to support the engine and attach the engine to the airframe. The engine is attached to the mount at four places using vibration isolator type shock mount assemblies, bolts, and self-locking type nuts. The engine mount is attached to the airframe at four places using bolts, washers, and nuts safetied with cotter pins.

ENGINE MOUNT - MAINTENANCE PRACTICES

1. Removal/Installation of Engine Mount

A. Remove Engine Mount (See Figures 201 and 202)

- (1) Remove power plant (refer to subsection 71-0, Power Plant Removal).
- (2) Disconnect all wiring, ties, and clamps attached to engine mount.
- (3) Remove nuts, washers, and bolts securing mount to engine mount supports, and remove mount.

B. Install Engine Mount (See Figures 201 and 202)

- (1) Position engine mount to engine mount supports and install mounting bolts, washers, and nuts.
- (2) Connect clamps and ties to mount.
- (3) Install power plant as outlined in subsection 71-0.

AA-5 SERIES
MAINTENANCE MANUAL

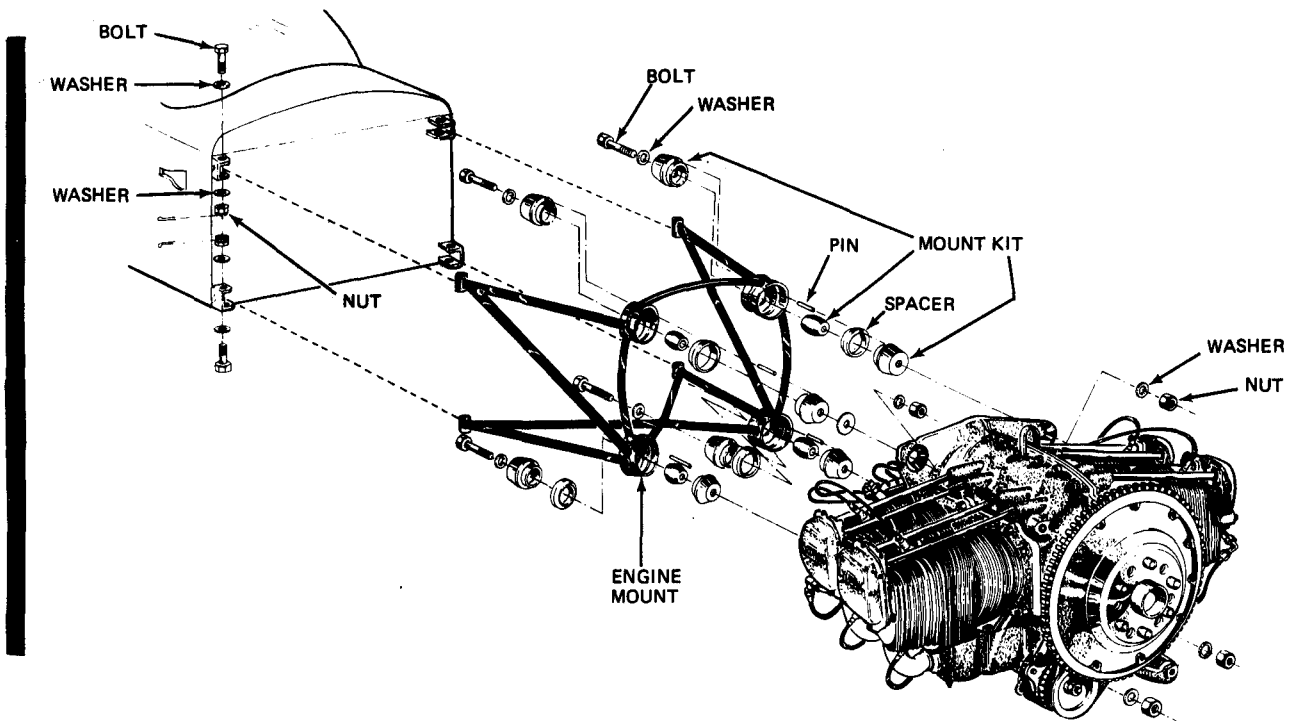

Engine Mount Installation-AA-5 and AA-5A
Figure 201

AA-5 SERIES
MAINTENANCE MANUAL

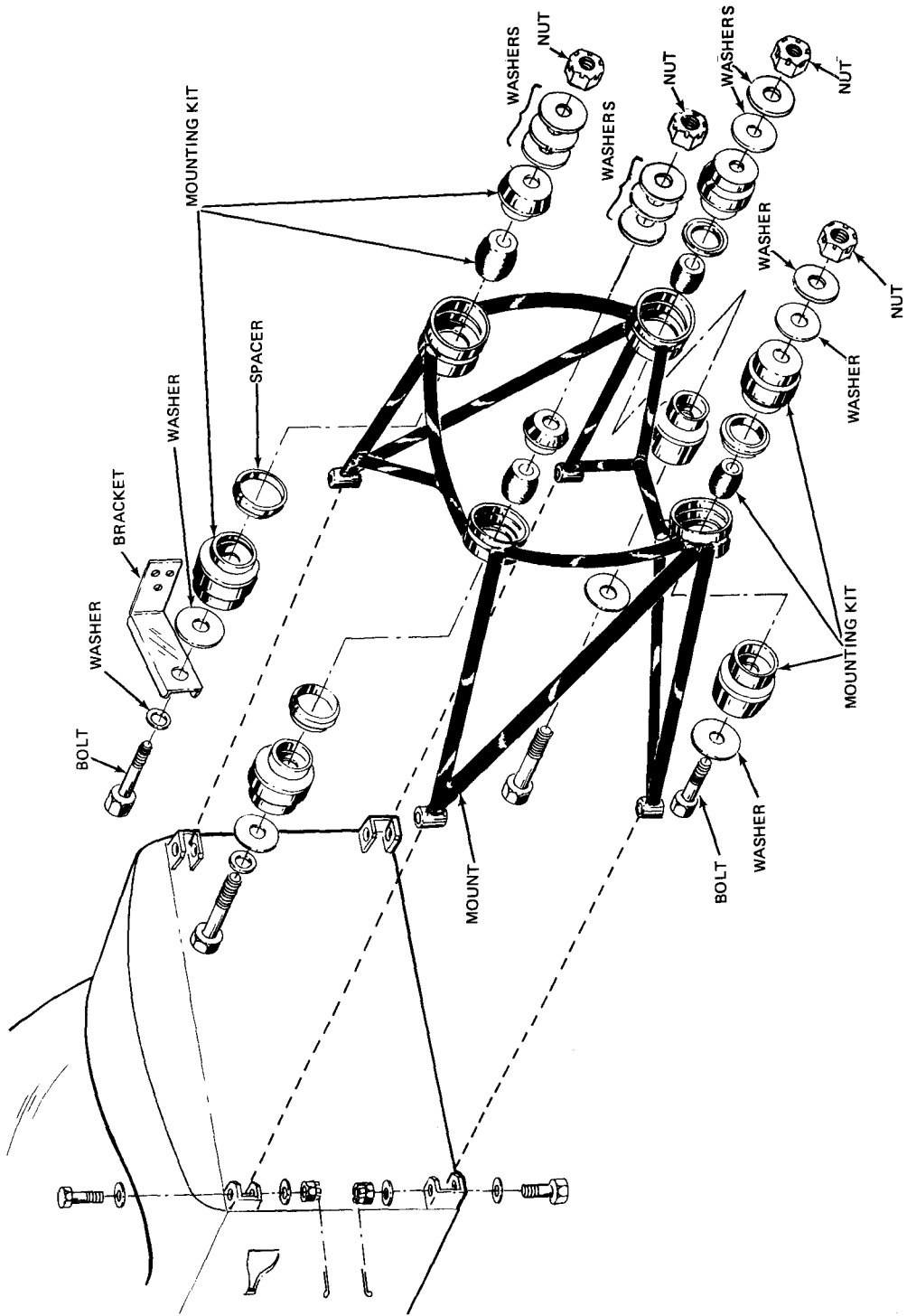

Engine Mount Installation - AA-5B
Figure 202

AA-5 SERIES
MAINTENANCE MANUAL

AIR INTAKES - DESCRIPTION/OPERATION

1. General (See Figure 1)

Openings in the forward cowl provide for entry of ram air to the engine. On the AA-5 and AA-5A an opening in the lower front of the forward cowl provides ram air directly to the carburetor air filter and then to the carburetor. On the AA-5B, ram air enters the openings in the forward cowl and is then picked up through an opening in the right hand side of the rear baffle and is ducted to the carburetor air box.

**AA-5 SERIES
MAINTENANCE MANUAL**

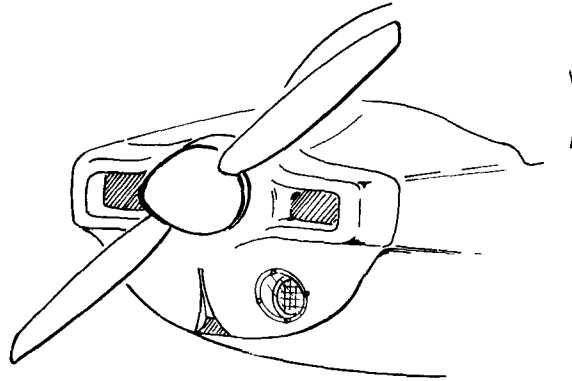

AA-5 SERIAL NO. 0641 AND SUBSEQUENT AND AA-5A

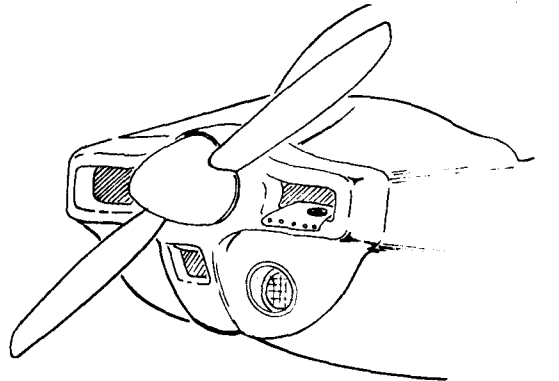

AA-5 SERIAL NO. 0001 THROUGH 0640

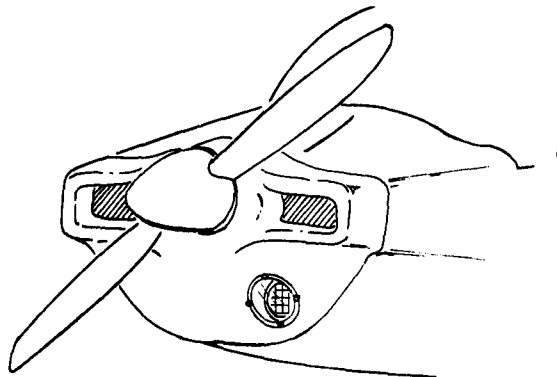

AA-5B

**Engine Air Intake Systems
Figure 1**

ENGINE BAFFLES - DESCRIPTION/OPERATION

1. General

The engine baffles are made from sheet aluminum with rubber-asbestos composition seals at point of contact with the engine cowling. The baffles are attached to the engine and direct the cooling air around the engine to provide optimum engine cooling. The complete baffles are composed of several segments which provides for easy removal and replacement of any single segment. The engine baffles should be inspected thoroughly at each periodic inspection for condition and security of mounting. Any loose or damaged baffles should be repaired or replaced.

ENGINE BAFFLES - MAINTENANCE PRACTICES

1. Removal/Installation of Engine Baffles

A. Remove Engine Baffles. (See Figures 201 and 202.)

- (1) Remove cowling as necessary to gain access. (Refer to Section 71-1-1)
- (2) Disconnect baffle springs on underside of engine.
- (3) Disconnect upper spark plug leads and pull lead ends through hole in rear baffles.
- (4) Disconnect braces to exhaust clamp on front baffles.
- (5) Disconnect air inlet flexible duct from front baffle.
- (6) Remove attaching screws and bolts that secure baffles to engine.
- (7) Remove screws that secure baffle segments together where necessary to remove individual segments and remove baffles.

B. Install Engine Baffles. (See Figures 201 and 202)

- (1) Assemble individual baffle segments in position on the engine and secure together with screws.
- (2) Install attaching screws and bolts that secure baffles to the engine.
- (3) Connect baffle springs on underside of engine.
- (4) Connect baffle-to-exhaust clamp braces on front baffle.
- (5) Connect air inlet flexible ducts to front baffle.
- (6) Pull spark plug leads through holes in rear baffle, install grommets in holes, and connect spark plug leads.
- (7) Install cowling. (Refer to Section 71-1-1)

AA-5 SERIES
MAINTENANCE MANUAL

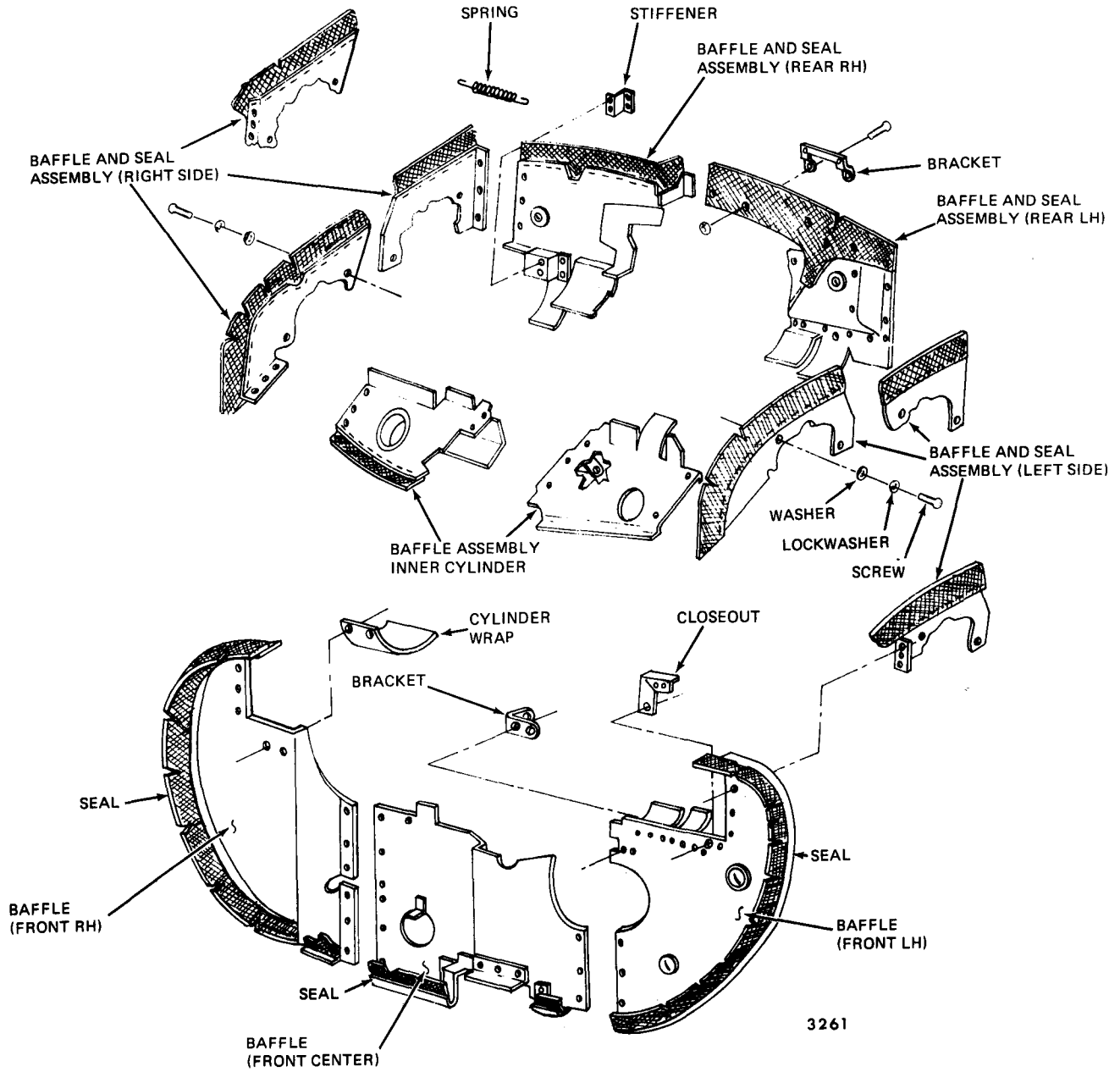

Engine Baffles - AA-5 and AA-5A
Figure 201

AA-5 SERIES
MAINTENANCE MANUAL

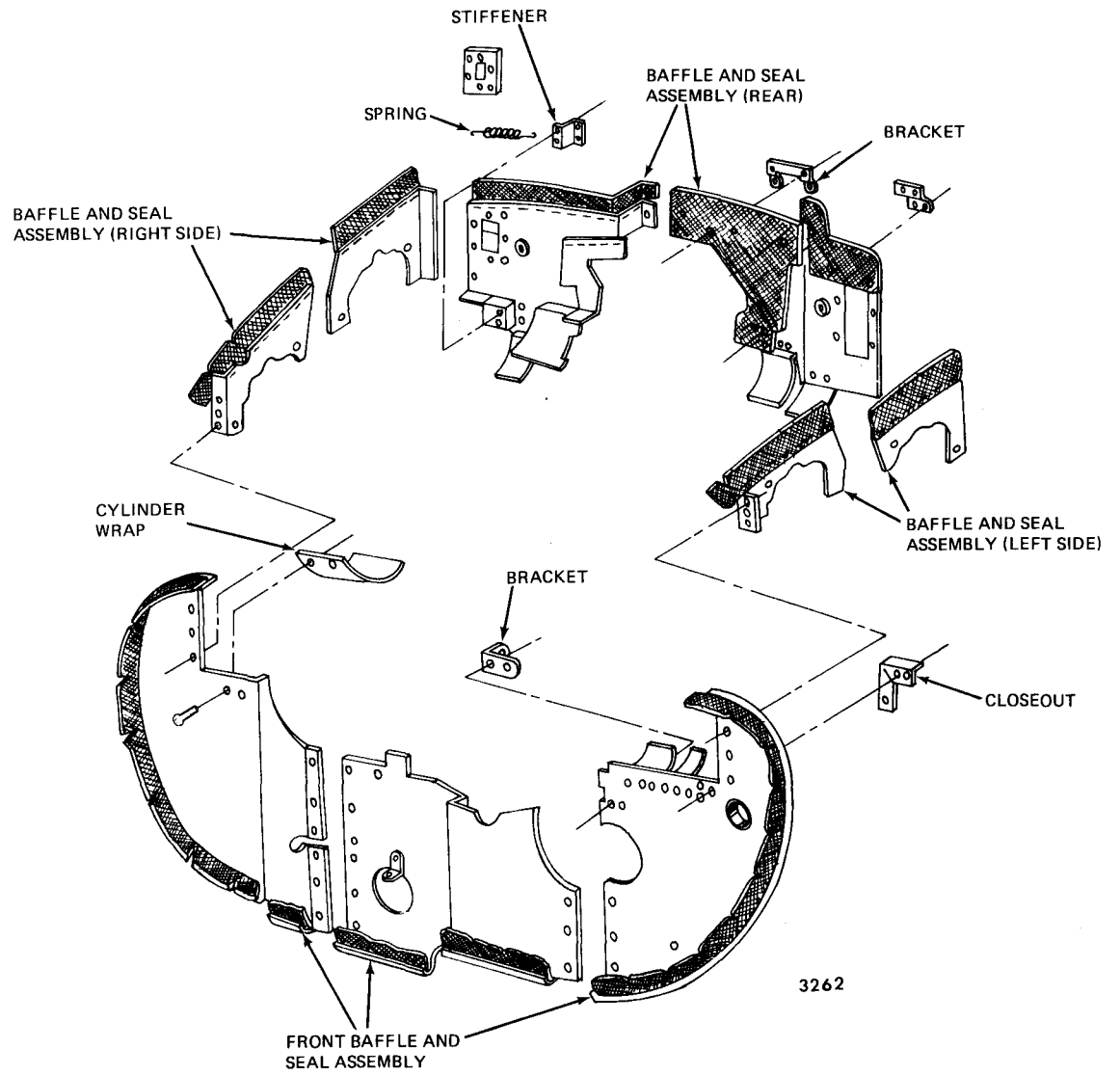

Engine Baffles - AA-5B
Figure 202

**AA-5 SERIES
MAINTENANCE MANUAL**

ENGINE DRAINS - DESCRIPTION

1. General

All drain lines are routed overboard through openings in the bottom of the lower cowl.

The engine breather line is a flexible line attached at the breather vent port in the top of the engine. The breather prevents an excessive pressure buildup inside the crankcase. The flexible line is extended by a piece of aluminum tubing attached to the flexible line with a spring clamp.

The fuel pump drain line may be either a clear plastic line attached to the pump vent by a spring type clamp or an aluminum line connected to a nipple vent by a nut. The battery box drain line is a short length of clear plastic tubing attached to the battery box drain with a spring type clamp. On the AA-5B, the carburetor air filter box drain is a short length of clear plastic tubing attached to the air box drain with a spring type clamp.

**AA-5 SERIES
MAINTENANCE MANUAL**

CHAPTER 73

ENGINE FUEL AND CONTROL

TABLE OF CONTENTS

| <u>NUMBER</u> | | <u>PAGE</u> |
|---------------|---|-------------|
| 73-0 | ENGINE FUEL AND CONTROL | |
| | Description/Operation | 1 |
| | General | 1 |
| 73-1-1 | AIR INDUCTION SYSTEM | |
| | Description/Operation | 1 |
| | General | 1 |
| | Maintenance Practices | 201 |
| | Removal/Installation of Air Induction System - AA-5 Serial No. 0001 through 0640 | 201 |
| | Removal/Installation of Air Induction System - AA-5 Serial No. 0641 and Subsequent and AA-5A | 201 |
| | Removal/Installation of Air Induction System - AA-5B | 204 |
| | Filter Servicing - AA-5 Serial No. 0001 through 0640 | 204 |
| | Filter Servicing - AA-5 Serial No. 0641 and Subsequent and AA-5A | 205 |
| | Filter Servicing - AA-5B | 205 |
| 73-1-2 | CARBURETOR | |
| | Description/Operation | 1 |
| | General | 1 |
| | Maintenance Practices | 201 |
| | Removal/Installation of Carburetor | 201 |
| 73-1-3 | ENGINE PRIMER SYSTEM | |
| | Description/Operation | 1 |
| | General | 1 |
| | Maintenance Practices | 201 |
| | Removal/Installation of Primer System | 201 |
| 73-2-1 | THROTTLE CONTROL | |
| | Description/Operation | 1 |

AA-5 SERIES
MAINTENANCE MANUAL

| <u>NUMBER</u> | | <u>PAGE</u> |
|---------------|--|-------------|
| | General | 1 |
| | Maintenance Practices | 201 |
| | Removal/Installation of Throttle Control | 201 |
| 73-2-2 | MIXTURE CONTROL | |
| | Description/Operation | 1 |
| | General | 1 |
| | Maintenance Practices | 201 |
| | Removal/Installation of Mixture Control | 201 |
| | Idle Speed and Mixture Adjustment | 204 |
| 73-3-1 | FUEL PRESSURE GAGE | |
| | Description/Operation | 1 |
| | General | 1 |
| | Maintenance Practices | 201 |
| | Removal/Installation of Fuel Pressure Gage | 201 |

**AA-5 SERIES
MAINTENANCE MANUAL**

ENGINE FUEL AND CONTROL - DESCRIPTION/OPERATION

1. General

The engine fuel and control system consists of the units and components which deliver metered fuel and air to the engine. The fuel portion includes the carburetor and associated controls, fuel primer, and fuel pressure indicator. The induction system consists of the air box assembly, flexible ducts, and air filters. The air portion includes the air induction system and associated controls. The fuel controls consist of the throttle and mixture control. The controls are located on the lower instrument panel.

Fuel induction system components that are an integral part of the engine are described in the Avco Lycoming Operator's Manual.

AIR INDUCTION SYSTEM – DESCRIPTION/OPERATION

1. General

The induction system consists of an air inlet housing and filter assembly. On AA-5 and AA-5A aircraft, the inlet housing aligns with an opening in the nose cowl which permits filtered outside air to enter the carburetor. On AA-5B aircraft, outside air enters the carburetor through a duct from the right rear baffle which directs air to the air box and filter housing. AA-5 aircraft Serial No. 0001 through 0640 has an oil saturated filter located in the induction inlet duct. AA-5 aircraft Serial No. 0641 and subsequent and AA-5A has a polyurethane type filter that is also located in the induction inlet duct. The AA5B-0001 through 0950 filter is a polyurethane type and is located in the air box/filter housing. Aircraft AA5B-0951 and subsequent use a paper type filter.

The induction system includes an alternate hot air source, which is controlled from the instrument panel. When carburetor icing conditions exist, the carburetor heat control can be pulled out to provide hot air to the carburetor intake.

NOTE: On AA-5, AA-5A, and AA-5B aircraft, limited operation of the carburetor heat control is recommended since no filter is incorporated in the hot air source.

AIR INDUCTION SYSTEM - MAINTENANCE PRACTICES

1. Removal/Installation of Air Induction System - AA-5 Serial No. 0001 through 0640

A. Remove Induction System (See Figure 201)

- (1) Remove the lower cowl assembly (refer to Chapter 71).
- (2) Loosen the clamp and disconnect the carburetor heat hose from the air box assembly.
- (3) Disconnect the carburetor heat control from the air box assembly.
- (4) Remove the bolts and lower the air box assembly from the carburetor.

B. Install Induction System

- (1) Position the air box assembly to the carburetor and forward cowl and install the bolts, being sure to install the left rear bolt with a washer to prevent it from bottoming out in the carburetor.
- (2) Connect the carburetor heat control to the air box assembly.
- (3) Install the carburetor heat inlet hose and clamp to the air box assembly.
- (4) Install the lower cowl.

NOTE: Make sure the air duct is properly fitted over the scoop in the forward cowl. Failure to do this could result in an inadequate air supply to the carburetor.

2. Removal/Installation of Air Induction System - AA-5 Serial No. 0641 and Subsequent and AA-5A

A. Remove Induction System (See Figure 202)

- (1) Remove the lower cowl assembly (refer to Chapter 71).
- (2) Loosen the clamp and disconnect the carburetor heat hose from the air box assembly.
- (3) Disconnect the carburetor heat control from the air box assembly.
- (4) Cut safety wire, remove the bolts, and lower the air box assembly from the carburetor.
- (5) Inspect the flex connection between the carburetor and air box assembly. Replace if damaged or otherwise defective.
- (6) Inspect and replace filter if damaged or if more than 50 percent covered with foreign material.

B. Install Induction System

- (1) Position the air box assembly on the carburetor, install the bolts and safety wire.
- (2) Install the carburetor heat inlet hose and clamp to the air box assembly.
- (3) Install the lower cowl.
- (4) Connect the carburetor heat control to the air box assembly.

AA-5 SERIES
MAINTENANCE MANUAL

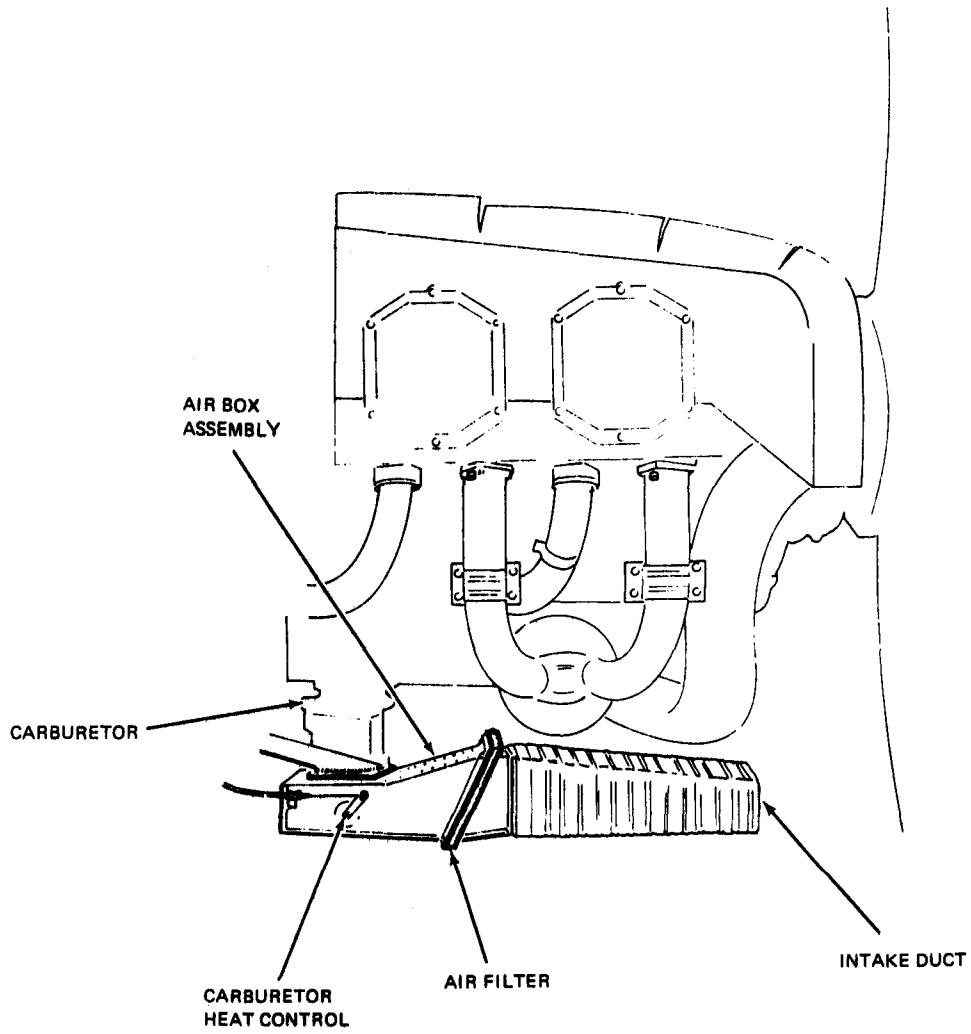

Air Induction System - AA-5
Figure 201

AA-5 SERIES
MAINTENANCE MANUAL

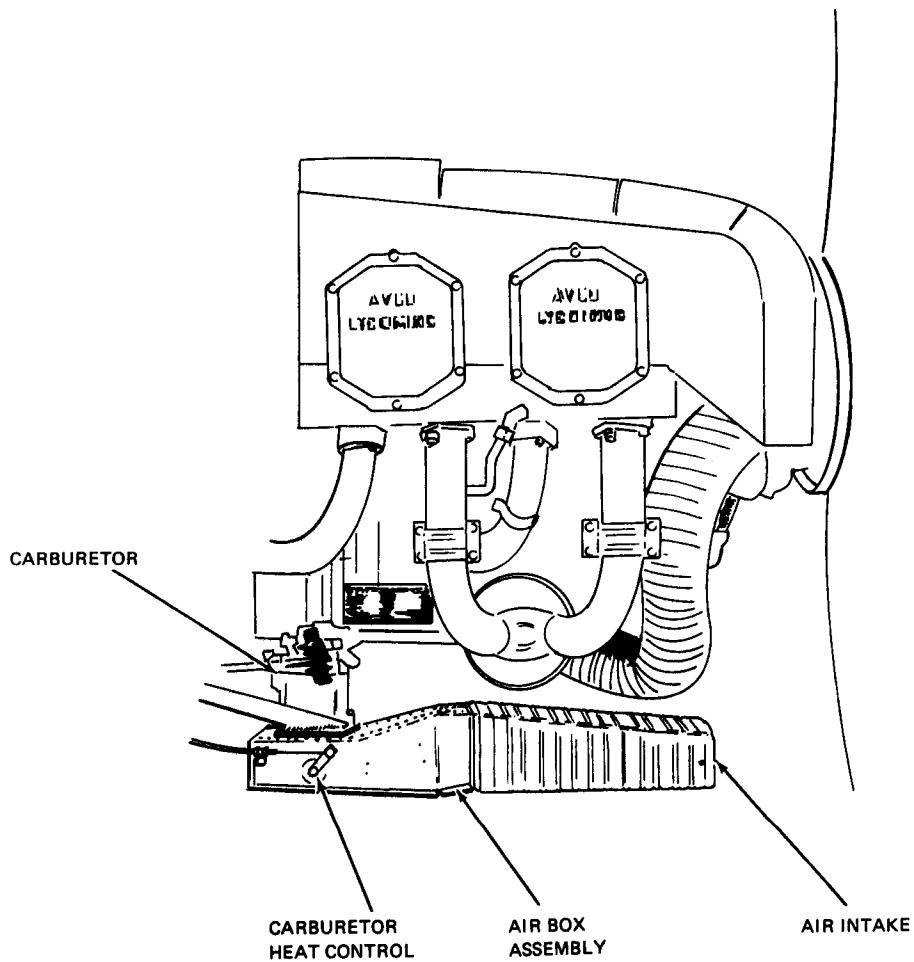

Air Induction System - AA-5A
Figure 202

3. Removal/Installation of Air Induction System - AA-5B

A. Remove Induction System (See Figure 203)

- (1) Remove the lower cowl assembly.
- (2) Loosen the clamps and disconnect the carburetor heat and induction air hoses from the air box/filter housing.
- (3) Disconnect the throttle, mixture, and carburetor heat controls from the housing.
- (4) Unbolt filter access door and remove filter.
- (5) From inside the air box/filter housing, cut safety wire, remove the attach bolts, and withdraw the housing from the aircraft.
- (6) Inspect all air box/filter housing seals and gaskets and replace if damaged.

B. Install Induction System

- (1) Position the air box/filter housing to the carburetor and install the bolts, being sure that mating gasket is properly installed between the surfaces. Safety wire attach bolts.
- (2) Install the filter and bolt the filter access door in the closed position.
- (3) Connect the throttle, mixture, and carburetor heat controls to the housing (refer to control installation instructions in this section).
- (4) Install the carburetor heat and induction air hoses and clamp to the air box/filter housing.
- (5) Install the lower cowl.

4. Filter Servicing - AA-5 Serial No. 0001 through 0640

A. Remove, Service, and Install Filter

- (1) Remove induction system.
- (2) Remove the screws attaching the adapter assembly, air filter and air box assembly together.
- (3) Thoroughly wash the filter in petroleum solvent. Make certain all dirt is removed and filter is in serviceable condition. If filter has flocking worn from screen wire, replace filter.
- (4) Dry the filter at room temperature. Filter must be completely dry before proceeding with next step. If the filter is not dry, the solvent will prevent oil from adhering to the filter, thereby reducing the filter efficiency.
- (5) Immerse the filter in the grade oil called for on the filter. If none is called out, use engine preservative oil. (Socony's "Avrex 901" or Esso's "Rust-Ban 626")
- (6) After removing the filter from the oil, allow it to drain thoroughly before installing in the aircraft.
- (7) Inspect the gasket between the air filter and air box; if damaged or otherwise defective, replace with a new gasket.
- (8) Position the air box assembly, filter, and adapter together and install the screws.
- (9) Install induction system.

5. Filter Servicing — AA-5 Serial No. 0641 and Subsequent and AA-5A

A. Remove, Service, and Install Filter

- (1) Remove screws on bottom side of lower cowl that attach filter cover plate and remove the plate.
- (2) If filter has any holes or tears, or is 50% covered with foreign material, replace filter.

NOTE: Never blow off filter with compressed air or attempt to wash element in any liquid or soak in oil. Filter should be replaced at each 100 hours, 12 calendar months, or when 50% covered with foreign material, whichever occurs first.

- (3) Position filter in place in air inlet duct.
- (4) Position filter cover plate in place on bottom of cowl and install screws.

6. Filter Servicing — AA-5B

A. Remove, Service, and Install Filter

- (1) Remove the lower cowl assembly.
- (2) Unbolt filter access door on the bottom of the air box/filter housing.
- (3) On aircraft with foam type filter installed, replace filter if filter has any holes or tears, or is 50% covered with foreign material.

NOTE: Never blow off filter with compressed air or attempt to wash element in any liquid or soak in oil. Filter should be replaced at each 300 hours, 12 calendar months, or when 50% covered with foreign material, whichever occurs first.

- (4) On aircraft with paper type filter installed, the filter may be cleaned by removing dust with compressed air or washed in a solution of water and Donaldson D-1400 filter cleaning compound or equivalent. Replace the filter after one year, after ten cleanings or after 500 flight hours.
- (5) Install filter in air box/filter housing and fasten filter access door bolt.
- (6) Install lower cowl assembly.

AA-5 SERIES
MAINTENANCE MANUAL

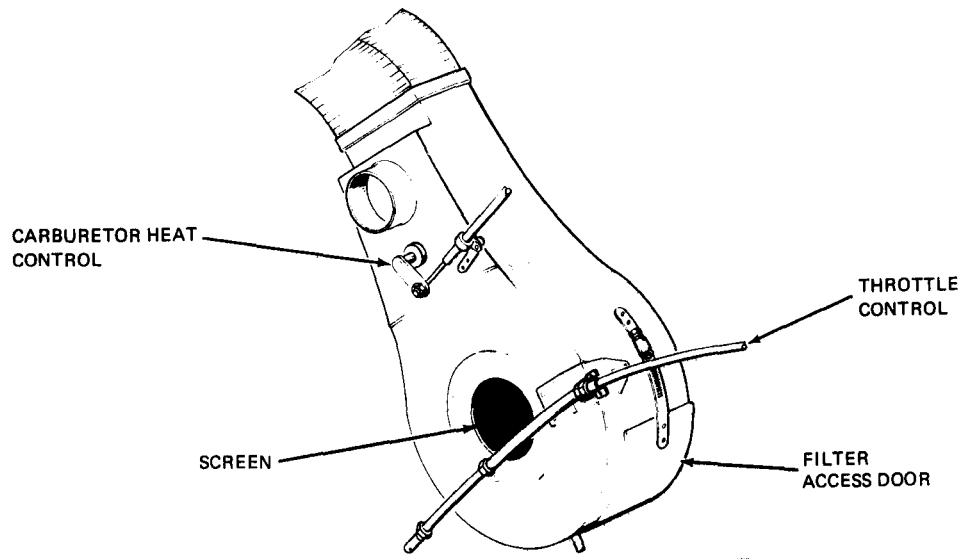

DETAIL A

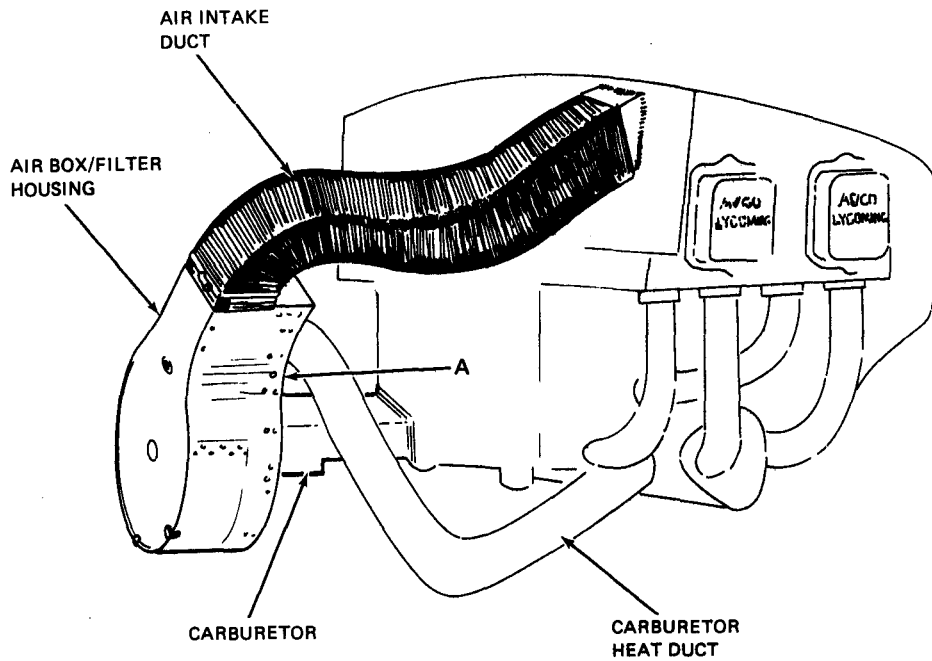

Air Induction System - AA-5B
Figure 203

AA-5 SERIES
MAINTENANCE MANUAL

CARBURETOR - DESCRIPTION/OPERATION

1. General

The engine is equipped with a single barrel, float-type carburetor, which incorporates an idle cut-off mechanism and a manual mixture control. On AA-5 and AA-5A aircraft the carburetor is mounted on the bottom of the engine. On AA-5B aircraft the carburetor is mounted horizontally on the rear of the engine.

CARBURETOR - MAINTENANCE PRACTICES

1. Removal/Installation of Carburetor

A. Remove Carburetor

- (1) Place fuel shut-off valve in OFF position.
- (2) Remove induction system (refer to 73-1-1).
- (3) Disconnect fuel inlet and fuel pressure lines at carburetor.
- (4) On AA-5 and AA-5A, remove throttle control support bracket.
- (5) Remove four nuts and washers and remove carburetor.

B. Install Carburetor

- (1) Using a new gasket, position carburetor to engine and install washers, nuts, and Pal nuts.
- (2) On AA-5 and AA-5A, use a new gasket and install gasket and throttle support bracket.
- (3) Connect fuel inlet and fuel pressure lines at carburetor.
- (4) Place fuel shut-off valve to ON position.
- (5) Place auxiliary fuel boost pump switch to ON position to pressurize the system and check connections for leaks.
- (6) Install induction system (refer to 73-1-1).

AA-5 SERIES
MAINTENANCE MANUAL

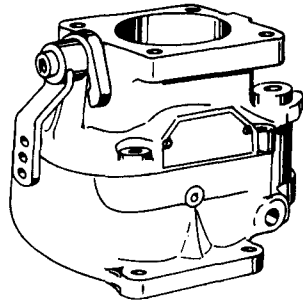

CARBURETOR

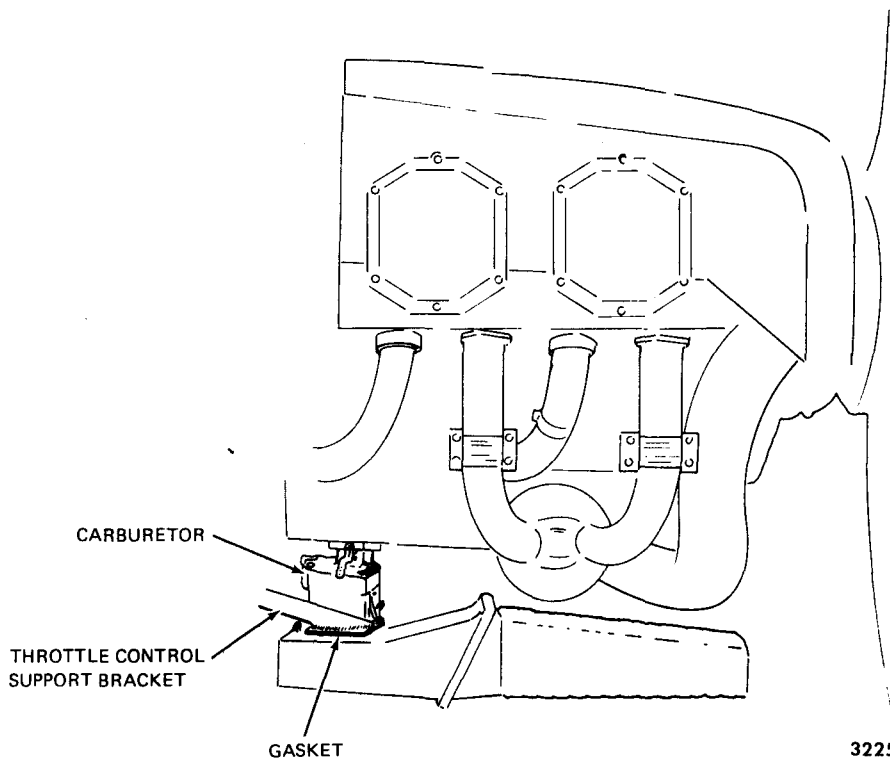

Carburetor Installation - AA-5, AA-5A
Figure 201

AA-5 SERIES
MAINTENANCE MANUAL

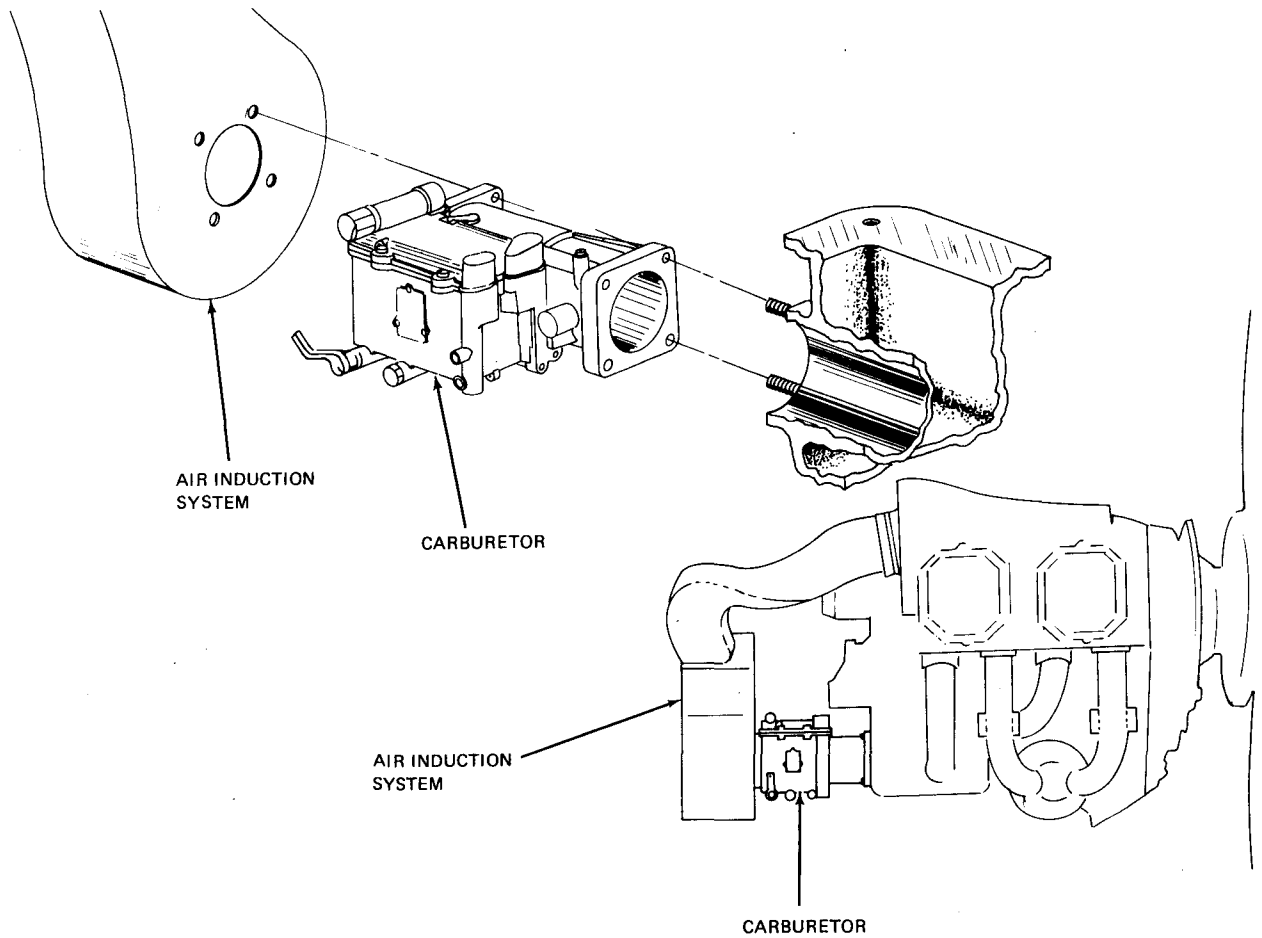

Carburetor Installation - AA-5B
Figure 202

**AA-5 SERIES
MAINTENANCE MANUAL**

ENGINE PRIMER SYSTEM - DESCRIPTION/OPERATION

1. General

The engine is equipped with a four cylinder priming system. Fuel is injected directly into the cylinder intake system by a plunger in the primer body located on the instrument panel. Fuel to the primer is obtained from a tee connection in the fuel line from the left sump. The primer knob can be locked in the closed position by pushing fully in and rotating either left or right until the knob cannot be pulled out. If a manifold pressure gauge is desirable, the priming system can be converted to a three cylinder system, and number three or number four cylinder used for the manifold pressure gauge connection.

ENGINE PRIMER SYSTEM - MAINTENANCE PRACTICES

1. Removal/Installation of Primer System

A. Remove Primer System (See Figures 201 and 202)

- (1) Remove the lower cowl.
- (2) Remove the line between the tee at rear of engine and the primer.
- (3) Remove the clamps securing the primer lines to the engine and the engine intake pipes and remove the primer lines from the engine.

NOTE: Do not disconnect the line from the tee connection at the left sump unless line is damaged. If the line must be removed for repair or replacement, drain the left fuel tank and sump.

- (4) Remove the knurled nut on the front of the instrument panel securing the primer.
- (5) Remove primer knob, plunger, spacer, and knurled nut as an assembly from the front of the instrument panel.
- (6) Remove primer body from rear of instrument panel.

B. Install Primer System

- (1) Assemble primer body, spacer, plunger, primer knob, and knurled nut on instrument panel and tighten nut.
- (2) Connect line between tee at rear of engine and primer-to-firewall connection.
- (3) Install primer lines to individual cylinders.
- (4) Connect primer line from firewall to tee connection.
- (5) Install clamps and secure primer lines to engine intake pipes and to engine.
- (6) Operate engine primer and check lines and connections for leaks.
- (7) After operating primer and checking system, allow sufficient time for excess fuel to drain overboard from the engine manifold before attempting an engine start.
- (8) Install lower cowl.

AA-5 SERIES
MAINTENANCE MANUAL

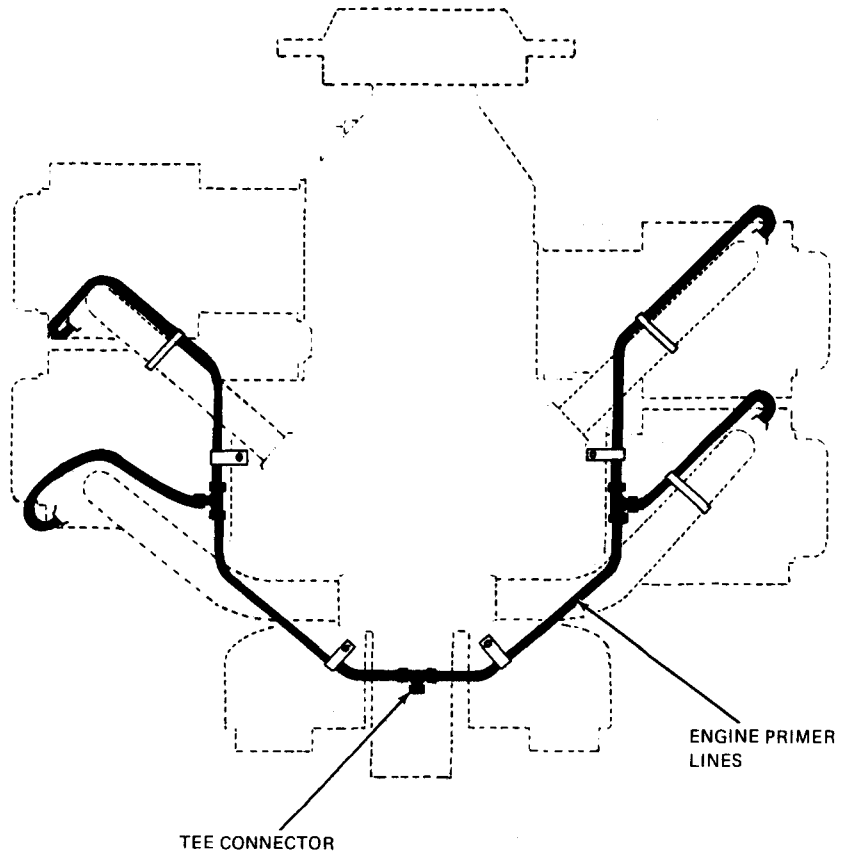

3230

Primer Lines Installation
Figure 201

AA-5 SERIES
MAINTENANCE MANUAL

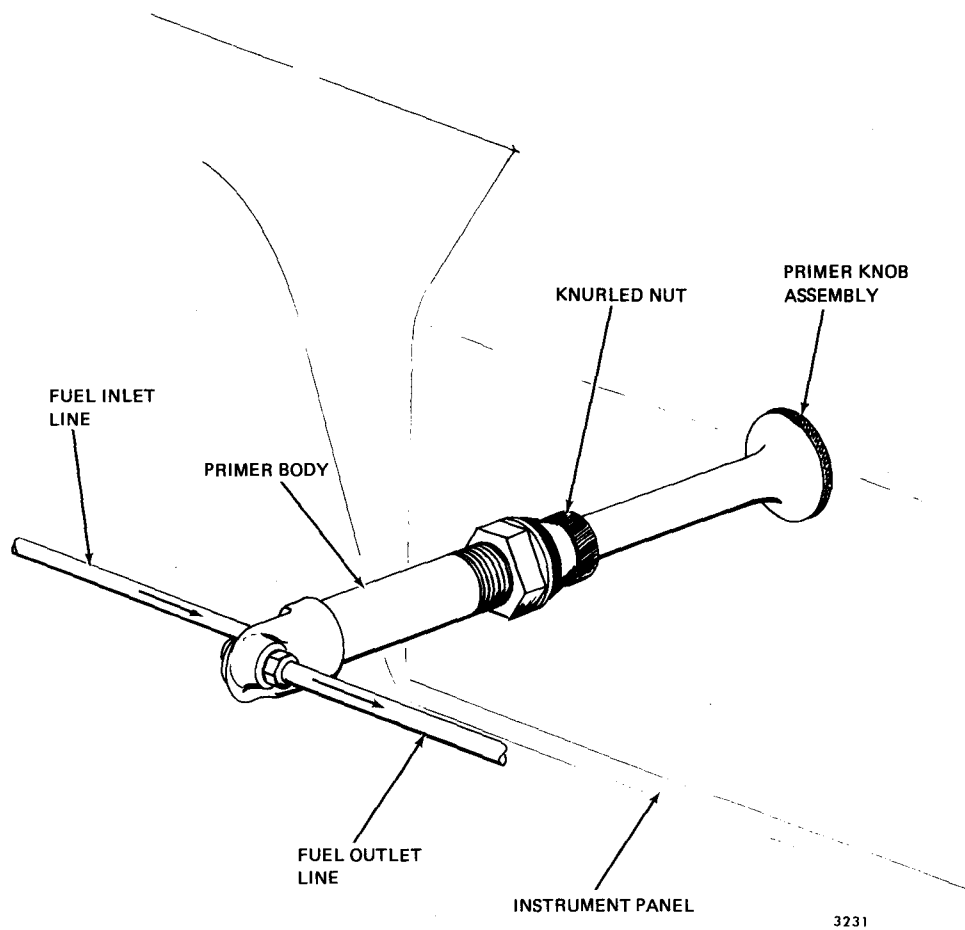

Engine Primer
Figure 202

AA-5 SERIES
MAINTENANCE MANUAL

THROTTLE CONTROL - DESCRIPTION/OPERATION

1. General

The throttle setting regulates the power output of the engine by controlling the amount of the fuel/air mixture that moves into the engine cylinders. The throttle control is located in the lower center of the instrument panel and is connected to the carburetor throttle valve by a flexible cable. The engine manifold pressure is controlled by the throttle settings.

THROTTLE CONTROL — MAINTENANCE PRACTICES

1. Removal/Installation of Throttle Control

A. Remove Throttle Control — Model AA-5

- (1) Remove cowl to gain access (refer to Chapter 71).
- (2) Disconnect the ball joint (1, Figure 201) from the carburetor throttle arm (2).
- (3) Remove the lock plate (3) which secures the throttle plunger sleeve (4) to the support bracket (5).
- (4) Loosen the jam nut (6) and remove the ball joint (1) and jam nut (6) from the throttle plunger (7). Remove the boots (8 and 9) from the plunger (7).
- (5) Remove the clamps (10) which secure the throttle cable and carburetor heat control cable to the instrument panel support. (Located between instrument panel and firewall.)
- (6) Remove the throttle housing retainer nut (11) from behind the instrument panel and carefully pull the throttle cable (12) through the firewall and instrument panel.

B. Install Throttle Control — Model AA-5

- (1) Pass the end of the throttle control cable (12, Figure 201) through the instrument panel and slide the housing retainer nut (11) over the end of the cable.
- (2) Route cable through the firewall to the carburetor.
- (3) Install and tighten the nut (11) on the throttle housing behind the instrument panel.
- (4) Position the throttle plunger sleeve (4) in the slot in the support bracket (5) and install the lock plate (3). Install the boots (8 and 9) on the plunger (7).
- (5) Position the throttle cable (12) to provide a minimum 4-1/2 inch bend radii and install the clamps (10).
- (6) Install the jam nut (6) and ball joint (1) loosely on the throttle plunger (7).
- (7) When a carburetor throttle arm has been removed, install as follows:
 - a. Check carburetor throttle arm (2) with arm against full open stop. Arm should be $55^{\circ} \pm 2^{\circ}$ forward of vertical as shown in Figure 201.
 - b. Torque throttle arm screw to 25-28 inch pounds and resafety.
 - c. On serrated type throttle arms, torque attaching nut to 30-48 inch pounds and install cotter pin.
- (8) Turn throttle knob (13) and jam nut (15) completely down, then tighten jam nut against throttle knob.
- (9) Place a 1/8 inch spacer between the throttle knob jam nut (15) and the friction lock (14) (friction lock partially loose).
- (10) Adjust the threaded ball joint (1) to position the carburetor throttle arm (2) against the full open stop. Check through the inspection hole in ball joint (1) that there is a minimum of 3/16 inch plunger rod engagement in the ball joint. Secure with jam nut (6).

AA-5 SERIES
MAINTENANCE MANUAL

- | | |
|----------------------------|-----------------------------------|
| 1. BALL JOINT | 9. BOOT |
| 2. THROTTLE ARM | 10. CLAMP |
| 3. LOCK PLATE | 11. THROTTLE HOUSING RETAINER NUT |
| 4. THROTTLE PLUNGER SLEEVE | 12. THROTTLE CABLE |
| 5. SUPPORT BRACKET | 13. THROTTLE KNOB |
| 6. JAM NUT | 14. FRICTION LOCK |
| 7. THROTTLE PLUNGER | 15. JAM NUT |
| 8. BOOT | 16. THROTTLE ARM CLAMP SCREW |

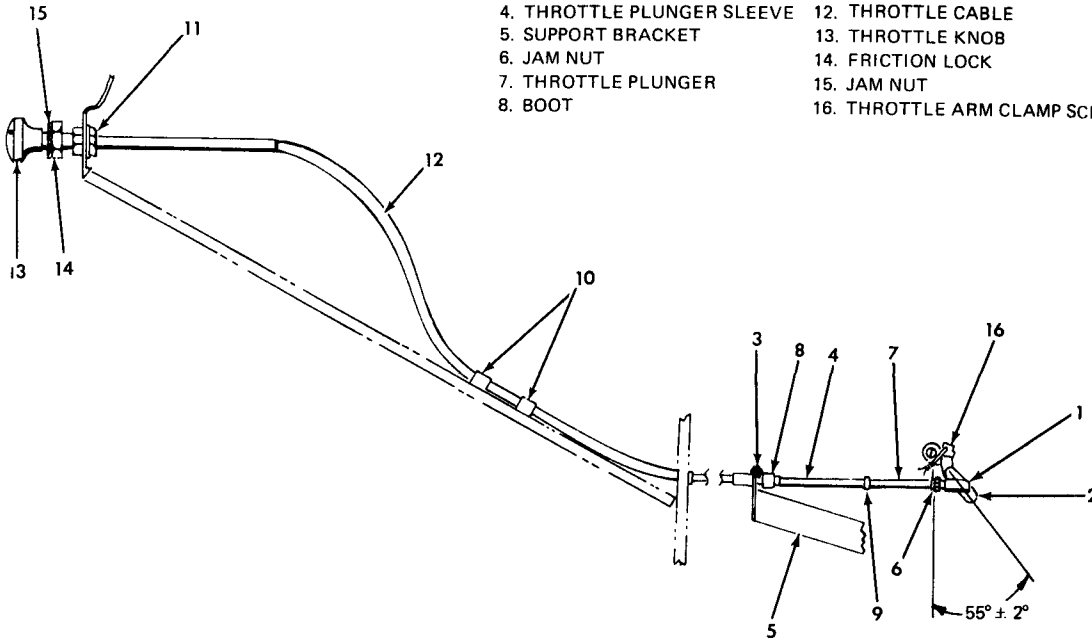

TIGHTEN THROTTLE ARM SCREW TO 26-28 IN.-LBS TORQUE. SAFETY THROTTLE ARM SCREW WITH LOCKWIRE, AS SHOWN.

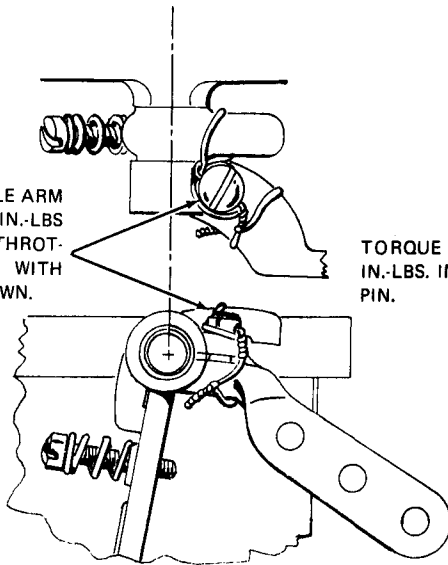

VIEW OF CARBURETOR THROTTLE ARM SHOWING METHOD OF TYING LOCKWIRE. (FRICTION CLAMP DESIGN)

TORQUE NUT TO 30-48 IN.-LBS. INSTALL COTTER PIN.

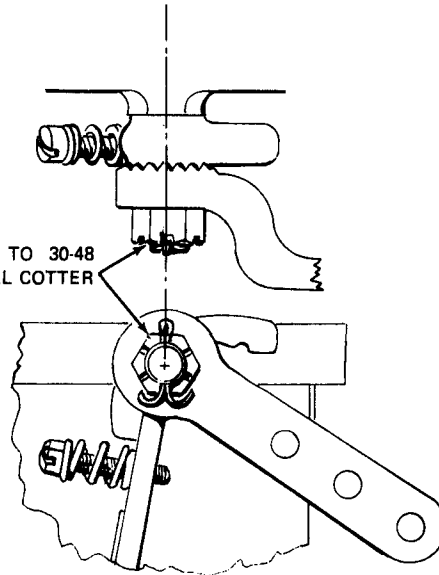

VIEW OF CARBURETOR THROTTLE ARM (SERRATED CLAMP DESIGN)

3272

Engine Throttle Control Installation - Model AA-5
Figure 201

**AA-5 SERIES
MAINTENANCE MANUAL**

- (11) If thread engagement in Step (10) above is less than 3/16 inch, the throttle knob (13) may be threaded out to 3/16 inch minimum thread engagement and Step (10) above repeated.
- (12) Space between throttle knob jam nut (15) and friction lock (14) with throttle fully open (friction lock partially loose) must be 1/8 to 1/4 inch maximum.
- (13) Check all attachments, jam nuts, safety wire and bend radii for correct installation, and throttle for smooth operation.
- (14) Install cowl (refer to Chapter 71).

C. Remove Throttle Control — Model AA-5B

- (1) Remove cowl to gain access (refer to Chapter 71).
- (2) Disconnect the ball joint (1, Figure 202) from the carburetor throttle arm (2).
- (3) Remove the clamp (6) which secures the throttle plunger sleeve (4) to the support bracket (14).
- (4) Loosen the jam nut (3) and remove the ball joint (1) and jam nut (3) from the throttle plunger (15). Remove the boots (5 and 13) from the plunger (15).
- (5) Remove the throttle housing retainer nut (9) from behind the instrument panel and carefully pull the throttle cable (8) through the firewall and instrument panel.

D. Install Throttle Control — Model AA-5B

- (1) Pass the end of the throttle control cable (8, Figure 202) through the instrument panel and slide the housing retainer nut (9) over the end of the cable.
- (2) Route cable through the firewall to the carburetor.
- (3) Install and tighten the nut (9) on the throttle housing behind the instrument panel.
- (4) Position the shim (16) and throttle plunger sleeve (4) in the support bracket (14) and install the clamp (6). Install the boots (5 and 13) on the plunger (15).

NOTE: The clamp tang must engage the slot in the throttle plunger sleeve to secure the throttle cable at the support bracket.

NOTE: Ensure that throttle cable minimum bend radius is 4-1/2 inches.

- (5) Install the jam nut (3) and ball joint (1) loosely on the throttle plunger (15).
- (6) Check carburetor throttle arm (2, Figure 202) with arm against full open stop. Arm should be 30° forward of vertical as shown in Figure 202. If throttle arm has been reinstalled, torque attaching nut 30 to 48 inch pounds and install cotter pin.
- (7) Turn throttle knob (12) and jam nut (11) completely down, then tighten jam nut against throttle knob.
- (8) Place a 1/8 inch spacer between the throttle knob jam nut (11) and the friction lock (10) (friction lock slightly loose).
- (9) Adjust the threaded ball joint (1) to position the carburetor throttle arm (2) against the full open stop. Check through the inspection hole in ball joint (1) that there is a minimum of 3/16 inch plunger rod engagement in the ball joint. Secure with jam nut (3).

**AA-5 SERIES
MAINTENANCE MANUAL**

NOTE: Space between plunger sleeve (4) and jam nut (3) with throttle closed must be 1/8 to 1/4 inch.

- (10) If thread engagement in Step (9) above is less than 3/16 inch, the throttle knob (12) may be threaded out to 3/16 inch minimum thread engagement and Step (9) above repeated.
- (11) Space between throttle knob jam nut (11) and friction lock (10) with throttle fully open (friction lock slightly loose) must be 1/8 to 1/4 inch maximum.
- (12) Check all attachments, jam nuts, and bend radii for correct installation, and throttle for smooth operation.
- (13) Install cowl (refer to Chapter 71).

AA-5 SERIES
MAINTENANCE MANUAL

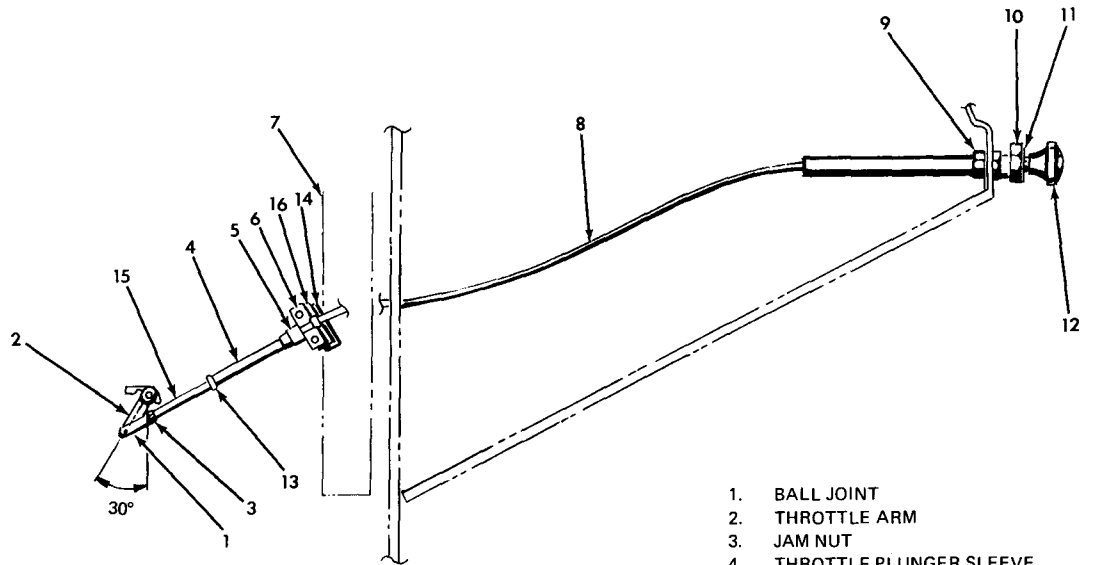

1. BALL JOINT
2. THROTTLE ARM
3. JAM NUT
4. THROTTLE PLUNGER SLEEVE
5. BOOT
6. CLAMP
7. AIR BOX ASSEMBLY
8. THROTTLE CABLE
9. THROTTLE HOUSING RETAINER NUT
10. FRICTION LOCK
11. JAM NUT
12. THROTTLE KNOB
13. BOOT
14. SUPPORT BRACKET
15. THROTTLE PLUNGER
16. SHIM

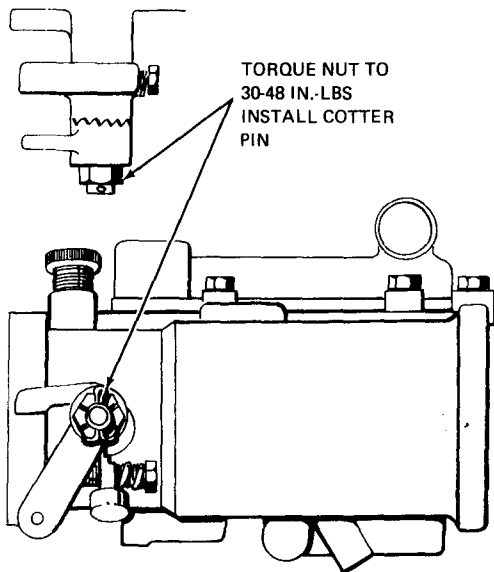

VIEW OF CARBURETOR
THROTTLE ARM

3274

Engine Throttle Control Installation - Model AA-5B
Figure 202

AA-5 SERIES
MAINTENANCE MANUAL

MIXTURE CONTROL - DESCRIPTION/OPERATION

1. General

The mixture control is located on the lower center of the instrument panel adjacent to the throttle control. The mixture control meters the amount of fuel that passes through the carburetor main jet, and is used to regulate fuel economy at a given power setting and cruising altitude.

MIXTURE CONTROL - MAINTENANCE PRACTICES

1. Removal/Installation of Mixture Control

A. Remove Mixture Control - AA-5 and AA-5A (See Figures 201 and 202)

- (1) Remove cowl to gain access (refer to Chapter 71).
- (2) Disconnect mixture control at carburetor by removing cotter pin, nut, washers, bearing, and bolt from mixture control arm.
- (3) Straighten mixture control wire and remove wire from swivel assembly.
- (4) Loosen the clamps at the firewall and instrument panel brace sufficiently to allow the cable to slide through.
- (5) Remove the nut securing the mixture control housing to the instrument panel and pull the mixture control cable through the firewall and instrument panel.

B. Install Mixture Control - AA-5 and AA-5A

CAUTION: DO NOT BEND OR KINK MIXTURE CONTROL CABLE DURING INSTALLATION.

- (1) Pass the end of the control cable through the instrument panel opening and slide the nut over the end of the cable and secure housing to instrument panel.
- (2) Continue the cable through the firewall, being sure it passes through the tie-wraps on the wiring and cable bundle and the clamps on the instrument panel brace and on the forward side of the firewall.
- (3) Pass the end of the cable through the bushing in the support bracket.
- (4) Assemble the bolt, bearing, washers, and nut loosely on the carburetor mixture control. Thread the wire through the hole in the swivel assembly.

NOTE: Do not bend wire or tighten bolt at this time.

- (5) Position the mixture control arm completely against the full rich stop. Place a 1/8-in. spacer between mixture control knob and control cable housing as shown in Figure 201.

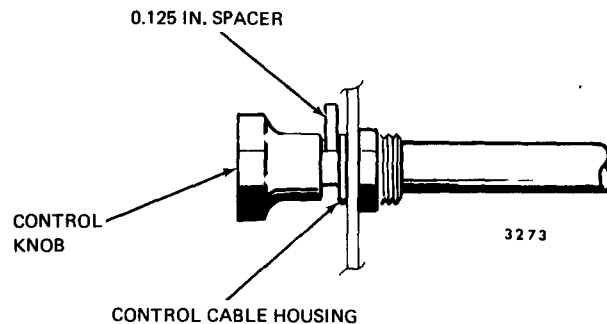

Typical Control Knob Rigging
Figure 201

AA-5 SERIES
MAINTENANCE MANUAL

- (6) With the mixture control arm against the full rich stop, and the control knob against the spacer, tighten the control arm attaching bolt and the cable clamps at the firewall and the instrument panel brace. Remove the spacer from control knob and check mixture control operation.
- (7) Bend mixture control cable wire as shown on Figure 202 and install the cotter pin.
- (8) Check operation of mixture control. Control should have 1/8 inch travel remaining with mixture control arm in full rich position. Control cable should have 4-1/2 inch minimum bend radius.
- (9) Install cowl (refer to Chapter 71).

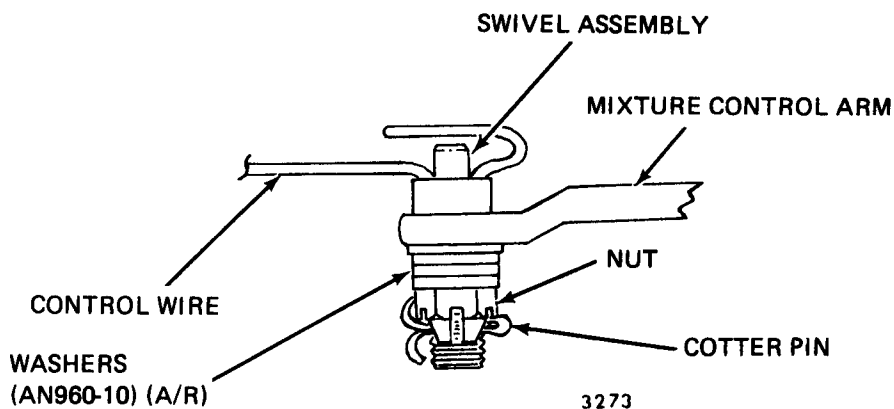

Mixture Control Wire Installation
Figure 202

C. Remove Mixture Control — AA-5B

- (1) Remove cowl to gain access (refer to Chapter 71).
- (2) Disconnect mixture control at carburetor by removing cotter pin, nut, washers, bearing, and bolt from mixture control arm.
- (3) Straighten mixture control wire and remove wire from swivel assembly.
- (4) Loosen clamp at bracket on carburetor sufficiently to allow the cable to slide through.
- (5) Remove sealant around cable at firewall.
- (6) Remove the nut securing the mixture control housing to the instrument panel and pull the mixture control cable through the firewall and instrument panel.

D. Install Mixture Control — AA-5B (See Figure 203.)

CAUTION: DO NOT BEND OR KINK MIXTURE CONTROL CABLE DURING INSTALLATION.

- (1) Pass the end of the control cable through the instrument panel opening and slide the nut and PVC tubing over the control cable housing.
- (2) Feed control cable through tie-wrap and firewall.
- (3) Secure control housing to instrument panel with the nut.
- (4) Feed control cable through tie-wrap on carburetor heat control cable and continue through clamp on carburetor.
- (5) Assemble the swivel assembly, washers, and nut loosely on the carburetor mixture control arm as shown in Figure 202. Thread the mixture control wire through the hole in the swivel assembly.

AA-5 SERIES
MAINTENANCE MANUAL

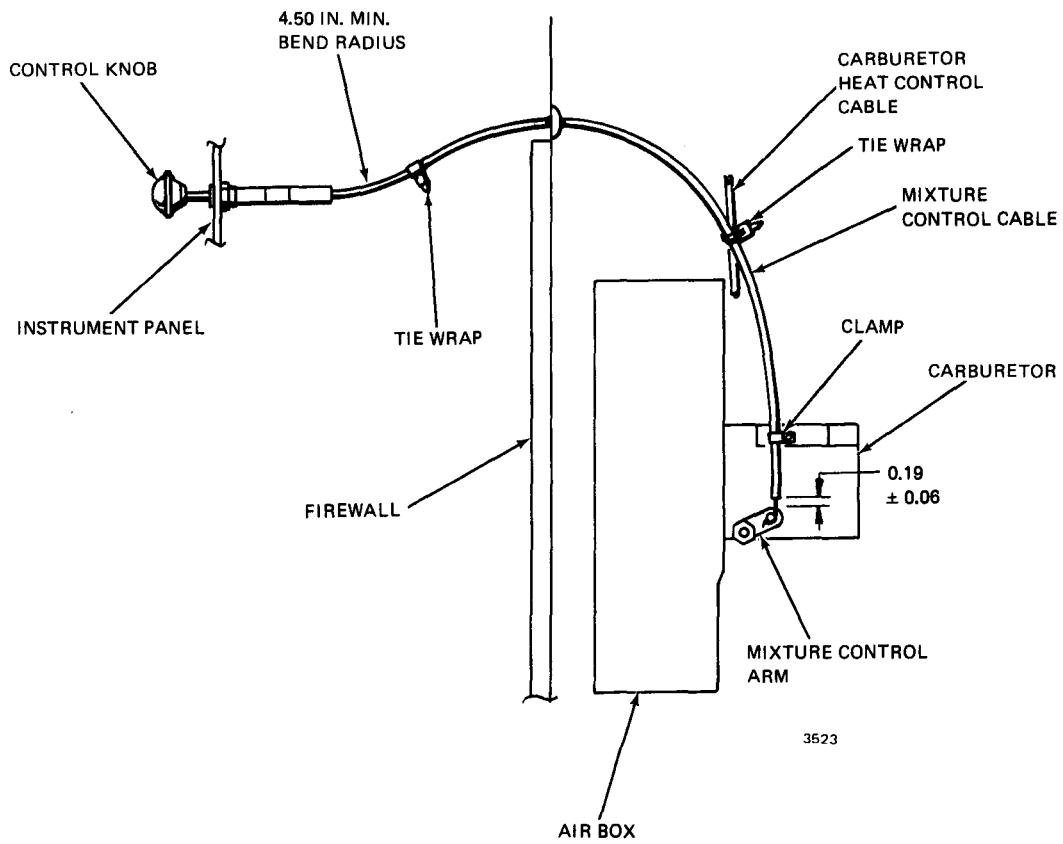

Mixture Control Cable Installation - AA-5B
Figure 203

**AA-5 SERIES
MAINTENANCE MANUAL**

NOTE: Do not bend wire or tighten nut on swivel at this time.

- (6) Place carburetor mixture control arm in the idle cut-off position and secure clamp on carburetor to locate cable housing 0.19 ± 0.06 inch from mixture control arm as shown in Figure 203.
- (7) Position the carburetor mixture control arm completely against the full rich stop. Place a 1/8 inch spacer between the mixture control knob and control cable housing as shown in Figure 201.
- (8) With the mixture control arm against the full rich stop and the control knob against the spacer, tighten the nut on the control arm swivel assembly as required to clamp the control wire securely.
- (9) Remove spacer behind control knob and operate mixture control through its full range of travel, making sure that control operates freely and smoothly. With mixture control arm against full rich stop, there must be a 1/8 inch clearance at the control knob as shown in Figure 201.
- (10) Bend mixture control wire as shown in Figure 202 and install cotter pin.
- (11) Ensure that mixture control cable has a 4-1/2 inch minimum bend radius.
- (12) Reseal firewall hole with Pro-Seal 700 Firewall sealant.
- (13) Install cowl (refer to Chapter 71).

2. Idle Speed and Mixture Adjustment

A. Adjust Idle Speed and Mixture Setting

- (1) Perform a normal engine warmup until oil temperature has stabilized.
- (2) With engine operating at 1800 rpm, check for normal magneto rpm drop (175 rpm maximum drop with no more than 50 rpm difference between magnetos).
- (3) Set the throttle stop idle speed adjustment screw on the carburetor so that the engine idles at 600 to 650 rpm, Model AA-5 and AA-5A or 500 to 650 rpm, Model AA-5B.
- (4) With a smooth and steady motion, pull the cockpit mixture control towards the idle cut-off position and observe the tachometer for any change. Return the control to the full rich position prior to the engine cutting out. An increase of more than 50 rpm while "leaning out" indicates an excessively rich idle mixture. An immediate decrease in rpm indicates the idle mixture is too lean.
- (5) If the procedure in Step (4) indicates the fuel mixture is too rich or too lean, turn the idle mixture screw in the carburetor to obtain the necessary correction, repeat step (4).
- (6) Each time the idle adjustment is changed, run the engine rpm up to 2000 rpm before proceeding with the next rpm check.
- (7) Check engine idle speed and if necessary, make final adjustments to obtain correct idle speed.

AA-5 SERIES
MAINTENANCE MANUAL

FUEL PRESSURE GAGE - DESCRIPTION/OPERATION

1. General

The fuel pressure gage is the lower gage in the instrument cluster assembly. The instrument cluster assembly is located on the right-hand side of the instrument panel. The gage is connected to the fuel inlet on the carburetor by an aluminum tube from the gage to the firewall and a flexible pressure line from the firewall to the fuel inlet on the carburetor.

FUEL PRESSURE GAGE - MAINTENANCE PRACTICES

1. Removal/Installation of Fuel Pressure Gage

A. Remove Fuel Pressure Gage

WARNING: BE SURE THAT MASTER SWITCH IS IN OFF POSITION.

- (1) Remove screws securing deck assembly to instrument panel.
- (2) Raise deck assembly and tape to windshield.

NOTE: Tag wiring to facilitate connection at installation.

- (3) Disconnect wiring and pressure lines from instrument cluster assembly.
- (4) Remove instrument cluster mounting screws and remove cluster assembly from instrument panel.
- (5) Remove nut from shell of inlet nipple on back of pressure gage and remove gage from cluster case.

B. Install Fuel Pressure Gage

WARNING: BE SURE THAT MASTER SWITCH IS IN OFF POSITION.

- (1) Position pressure gage in instrument cluster case and install nut on gage nipple at back of case.
- (2) Position instrument cluster in place on instrument panel and install mounting screws.
- (3) Connect pressure lines and wiring to instrument cluster assembly and remove tags installed at removal.
- (4) Place deck assembly in position and install screws securing deck assembly to instrument panel.

AA-5 SERIES
MAINTENANCE MANUAL

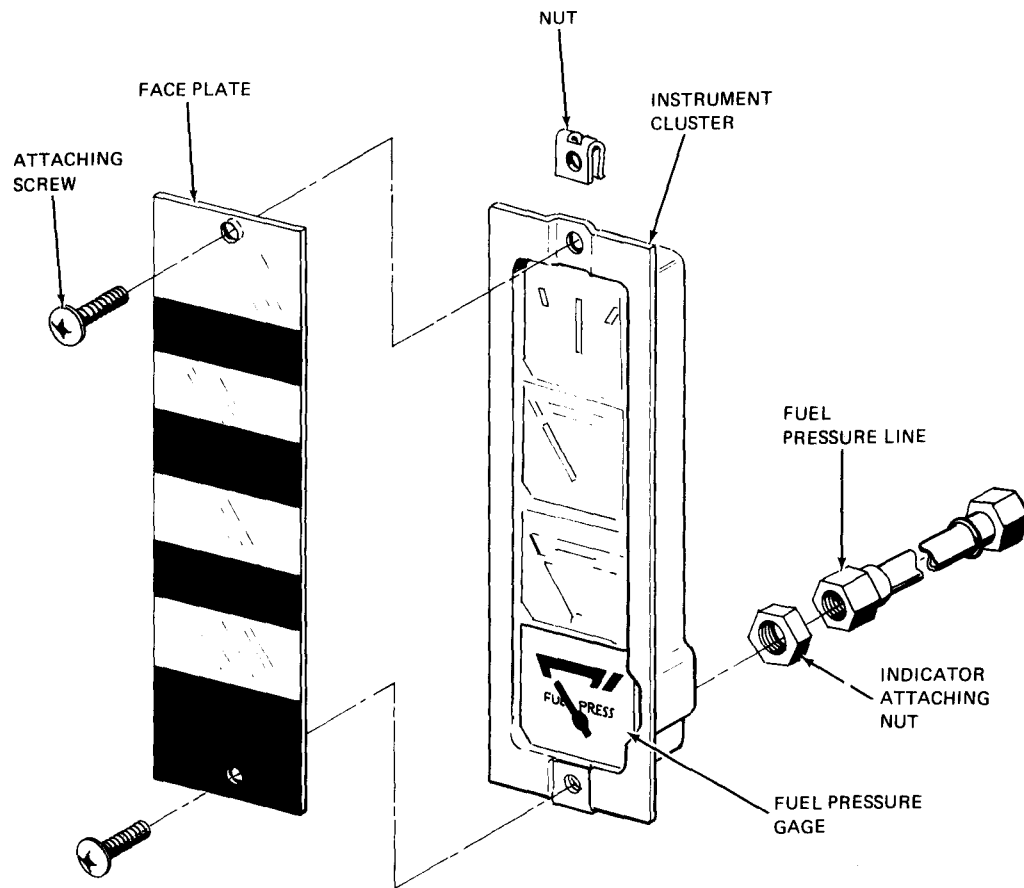

3232

Fuel Pressure Gage Installation
Figure 201

AA-5 SERIES
MAINTENANCE MANUAL

CHAPTER 74

IGNITION

TABLE OF CONTENTS

| <u>NUMBER</u> | | <u>PAGE</u> |
|---------------|--|-------------|
| 74-0 | IGNITION SYSTEM | |
| | Description/Operation | 1 |
| | General | 1 |
| | Maintenance Practices | 201 |
| | Inspection of Ignition System Components | 201 |
| | Removal/Installation of Ignition System Components | 201 |

AA-5 SERIES
MAINTENANCE MANUAL

IGNITION SYSTEM - DESCRIPTION/OPERATION

1. General

The ignition system components generate, control, and distribute an electrical current to ignite the fuel-air mixture in the cylinders. The engine dual ignition system consists of the magnetos, shielded harness, spark plugs and the ignition switch. The magnetos are a sealed, lightweight type requiring no internal adjustments. Timing the magneto to the engine at installation is the only adjustment required. Each lead of the ignition harness can be removed separately. The ignition switch is located on the lower left-hand side of the instrument panel.

IGNITION SYSTEM - MAINTENANCE PRACTICES

1. Inspection of Ignition System Components

- A. Check magneto harness for security of mounting clamps, tight connections, and frayed shielding.

WARNING: USE SOLVENTS IN A WELL VENTILATED AREA. AVOID BREATHING FUMES.
KEEP AWAY FROM FLAMES.

- B. Examine spark plug lead shielding, compression springs, and ceramics for corrosion and deposits. If this condition exists, clean the leads and ceramics with a clean cloth moistened with methyl-ethyl-ketone.

NOTE: If lead has been disassembled, see Figure 201 for correct arrangement at reassembly.

- C. Remove and check spark plugs for proper gap and evidence of fouling. Clean and regap plugs if necessary. (See latest revision of Lycoming Service Instruction No. 1042). Plugs should be rotated upper-to-lower every 100 hours of plug service life, or sooner if lead fouling occurs.
- D. Check magnetos to engine timing. If necessary, time the magnetos to the engine. The magneto to engine timing check should be made every 100 hours.

2. Removal/Installation of Ignition System Components

- A. Remove Ignition Harness.

- (1) Remove cowl as necessary to gain access.
- (2) Tag or identify each lead for reference at installation.
- (3) Disconnect harness leads at spark plugs.
- (4) Remove clamps securing the harness to the cylinder head.
- (5) Remove harness ties to engine mount.
- (6) Remove plastic ties as necessary to separate harness leads.
- (7) Remove attaching screws from magneto caps.
- (8) Remove the magneto caps and harness as an assembly.

- B. Install Ignition Harness.

- (1) Route ignition harness leads as shown in Figure 202. (For alternate ignition lead routing, see Lycoming Service Instruction No. 1294).
- (2) Install ignition harness leads and magneto caps on magnetos.
- (3) Connect ignition harness leads to spark plugs. Tighten nut finger tight plus one-fourth turn.
- (4) Install plastic ties on harness as necessary.
- (5) Install clamps securing ignition leads to cylinder heads as necessary.
- (6) Secure ignition harness to engine mount as necessary.

AA-5 SERIES
MAINTENANCE MANUAL

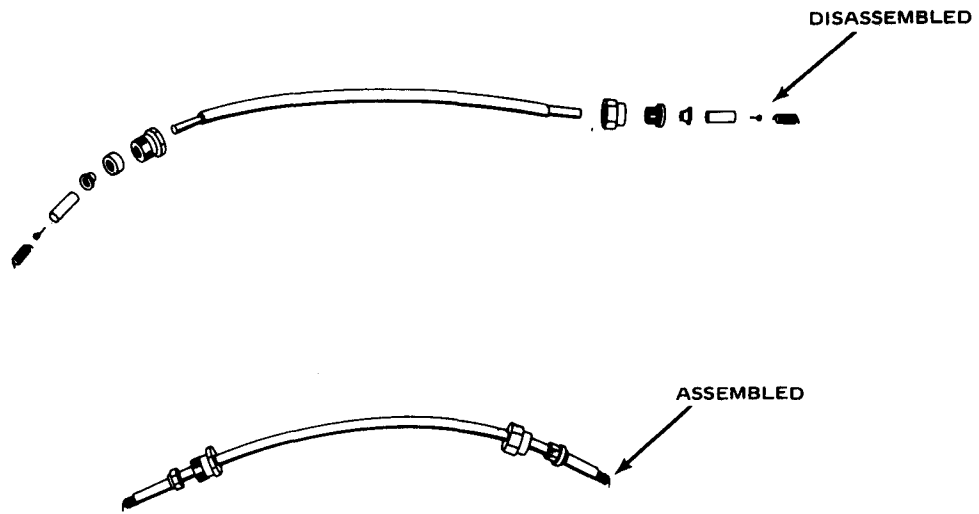

Magneto Lead Arrangement
Figure 201

AA-5 SERIES
MAINTENANCE MANUAL

(7) Remove identification tags installed prior to removal.

(8) Install cowl.

C. Remove Spark Plugs.

(1) Remove cowl as necessary to gain access.

(2) Disconnect ignition harness leads from spark plugs.

(3) Remove spark plugs.

D. Install Spark Plugs.

(1) Apply anti-seize compound on all but first two threads of the spark plug.

(2) Install spark plugs and torque to 360 - 420 inch-pounds.

(3) Install ignition harness leads to spark plugs. Tighten nut finger tight plus one-fourth turn.

(4) Install cowl.

E. Remove Magneto.

WARNING: DURING ALL MAGNETO MAINTENANCE, TAKE PROPER PRECAUTIONS TO MAKE SURE THE ENGINE CANNOT FIRE OR START WHEN THE PROPELLER IS MOVED.

(1) Remove cowl as necessary to gain access.

(2) Disconnect the magneto ground wire and shielding terminal.

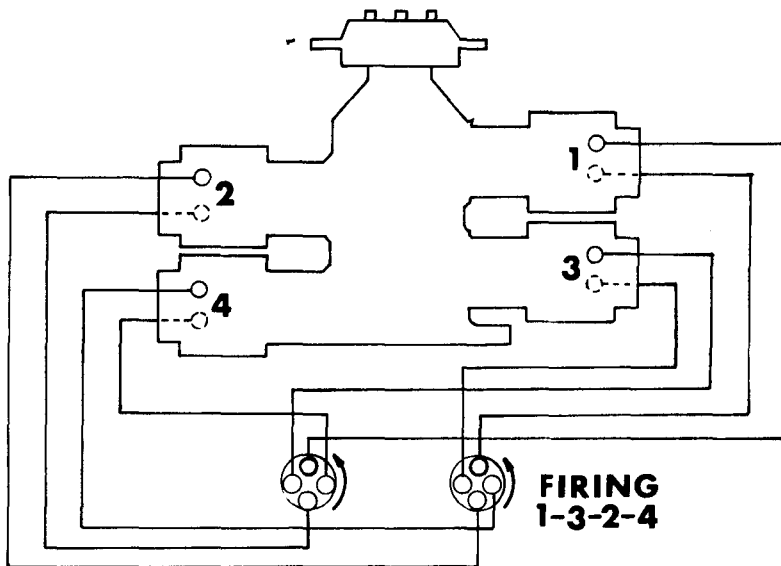

3276

Ignition System Schematic
Figure 202

**AA-5 SERIES
MAINTENANCE MANUAL**

- (3) Remove the distributor cap assembly.
- (4) Remove the mounting lugs and withdraw the magneto.

NOTE: Make a note of the approximate angle the magneto makes with the engine centerline as an aid in its subsequent installation.

F. Install Magneto

- (1) Rotate the propeller in the normal direction of rotation until No. 1 cylinder enters its compression cycle.

NOTE: (1) To determine if the No. 1 cylinder is in the compression cycle, remove the top plug from the No. 1 cylinder and place thumb over the port. As the piston approaches the end of the compression stroke, a positive pressure will try to force the thumb off the port.

(2) The ring gear (flywheel) may be marked at 20° or 25°. Consult Engine Specifications for correct timing mark for your installation.

- (2) Continue turning the propeller in the normal direction of rotation until the advanced timing mark on the forward face of the flywheel becomes aligned with the small hole drilled in the head of the starter casing. Alternate method is to align the advance mark on the back of the flywheel with the crankcase parting line. At this point, the engine is ready to receive the magnetos. (See Figure 203.)

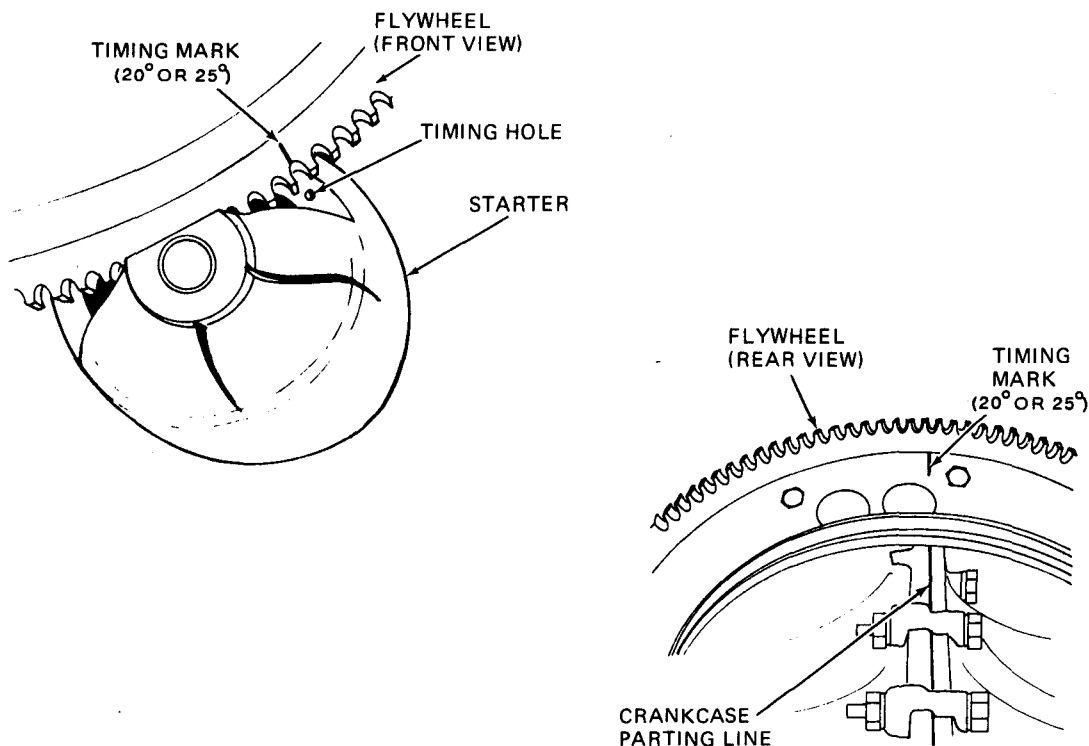

Advance Timing Alignment
Figure 203

AA-5 SERIES
MAINTENANCE MANUAL

- (3) Remove the plug from the bottom of the magneto.

NOTE: In order to rotate the magneto incorporating on impulse coupling, depress the pawl on the impulse coupling with the finger.

- (4) Rotate the magneto shaft until a spark occurs from number one lead (hold screw driver close to No. 1 lead while turning the shaft). As soon as the spark occurs, slowly reverse direction until the timing hole in the rotor is centered in the plug opening. (See Figure 204.)

NOTE: Failure to spark check the number one position leaves the possibility of the magneto being 180° out of phase. The timing hole appears in the plug opening twice for every complete firing cycle.

- (5) Insert a pin (0.093" diameter) into the timing hole in order to keep the rotor in the timed position.

NOTE: On Slick magnetos, use the special Slick timing pin.

- (6) Position the magneto into the crankcase at the approximate angle noted on removal. Be sure gasket is installed behind the magneto mounting flange.

- (7) Install the attach clip over the magneto mounting flange and tighten the nut finger-tight.

NOTE: Install the magneto with the impulse coupling on the left side.

- (8) Install the second magneto in the same manner as described in steps (3) through (7) above.

CAUTION: BE SURE TO NOT ROTATE THE PROPELLER WITH THE PIN STILL INSTALLED IN THE MAGNETO TIMING HOLE.

- (9) Final timing should be accomplished with a timing light. Using a battery powered timing light, attach the positive leads to the magneto ground terminal, and the negative leads to any unpainted portion of the engine.

- (10) Remove the pins from the magnetos.

- (11) Rotate the magneto in its mounting flange until the light comes on. Slowly turn the magneto in the opposite direction until the light goes off. Bring the magneto back slowly until the light just comes on.

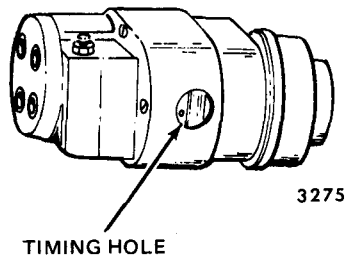

Magneto Timing Hole
Figure 204

**AA-5 SERIES
MAINTENANCE MANUAL**

- (12) Repeat this process for the other magneto.
- (13) Upon timing both magnetos, check to ascertain that both magnetos will fire simultaneously.

NOTE: To check the simultaneous firing of both magnetos, back off on the propeller a few degrees (timing light should go out). Bring the propeller back slowly in the direction of normal rotation until the 25° advanced timing mark aligns with the hole in the starter casing. At this point, both lights should go on simultaneously. When timing the magneto to the engine, a maximum tolerance of $\pm 2^\circ$ is allowable.

- (14) Tighten the magneto mounting nuts and torque to 150 inch-pounds and install magneto ground wire and shielding terminal.
- (15) When the magneto shows an excessive rpm loss or has reached a total of 900 hours, whichever comes first, the magneto should be returned to the magneto manufacturer for exchanging. No attempt should be made to repair the magneto in the field since disassembly of the magneto will void its warranty.

NOTE: If the drive shaft nut has been removed from the magneto incorporating the impulse coupling, care should be exercised when reassembling, not to overtighten. The recommended torque is 156 inch-pounds. Torque may be increased to line up hole with slot in nut.

AA-5 SERIES
MAINTENANCE MANUAL

CHAPTER 77
ENGINE INDICATING
TABLE OF CONTENTS

| <u>NUMBER</u> | | <u>PAGE</u> |
|---------------|---|-------------|
| 77-0 | ENGINE INDICATING SYSTEM | |
| | Description/Operation | 1 |
| | General | 1 |
| 77-1-1 | TACHOMETER | |
| | Description/Operation | 1 |
| | General | 1 |
| | Maintenance Practices | 201 |
| | Removal/Installation of Tachometer and Tachometer Cable | 201 |

**AA-5 SERIES
MAINTENANCE MANUAL**

ENGINE INDICATING SYSTEM - DESCRIPTION/OPERATION

1. General

Because of the simplicity of the engine installed in AA-5, AA-5A and AA-5B aircraft a limited number of engine indicating instruments are required. Most of the engine indicating instruments are discussed in their specifically related system chapter. This chapter covers only the tachometer.

**AA-5 SERIES
MAINTENANCE MANUAL**

TACHOMETER - DESCRIPTION/OPERATION

1. General

The tachometer is a mechanical indicator mounted on the lower center of the instrument panel and driven by a flexible shaft. It measures the rate at which the crankshaft revolves in revolutions per minute (rpm), and is calibrated in hundreds of rpm. The instrument also incorporates a recording mechanism to keep an accurate record of engine hours.

The tachometer provides the pilot with throttle control information necessary in making required power settings and adjustments for takeoff, climb, cruise, and descent. The tachometer is also used when making magneto checks and for maintenance checks of the engine. The formation of carburetor ice is indicated by a drop in engine rpm.

The tachometer is color coded for easy interpretation. A green arc on the face of the instrument indicates the normal, safe operating range. The red line is the maximum allowable rpm. On the AA-5B tachometer a yellow arc extends from 1850 - 2250 rpm to indicate a caution range to the pilot. Continued engine operation in flight within the caution range may result in some engine vibration.

TACHOMETER - MAINTENANCE PRACTICES

1. Removal/Installation of Tachometer and Tachometer Cable

A. Remove Tachometer (See Figure 201)

- (1) Disconnect tachometer flexible cable at rear of instrument panel.
- (2) Remove four mounting screws and remove tachometer.
- (3) Install plastic cover or masking tape over nipple on tachometer.

B. Install Tachometer

- (1) Connect flexible cable to tachometer making sure that cable is seated in driveshaft.
- (2) Position tachometer on rear of instrument panel and install the four mounting screws.

C. Remove Tachometer Cable and Housing

- (1) Remove cowl to gain access (refer to Chapter 71).

NOTE: If cable only needs removing, disconnect cable at tachometer and pull cable out of housing.

- (2) Cut plastic clamps both forward and aft of firewall, and free wiring from flexible cable.
- (3) Disconnect cable from tachometer and from engine.
- (4) Cover connections on engine and tachometer with masking tape or plastic caps.
- (5) Pull cable and housing through firewall.
- (6) Pull cable out of housing.

D. Install Tachometer Cable and Housing

- (1) If cable only has been removed, apply approved graphite base lubricant to cable and insert in housing as far as it will go and rotate slowly to make sure cable is seated in engine fitting. Connect cable to tachometer.
- (2) Check cable and housing for dents, kinks, or evidence of damage.
- (3) Apply approved graphite base lubricant to cable and insert into the housing.
- (4) Insert cable assembly through firewall and connect to engine and tachometer making sure that cable ends are properly seated.
- (5) Using plastic clamps, secure wiring to cable housing as necessary both forward and aft of firewall.
- (6) Start engine and check tachometer for proper operation.
- (7) If tachometer is erratic or noisy, check for loose connections or sharp bends in cable. No bend radius should be less than 6 inches.
- (8) Install cowl (refer to Chapter 71).

AA-5 SERIES
MAINTENANCE MANUAL

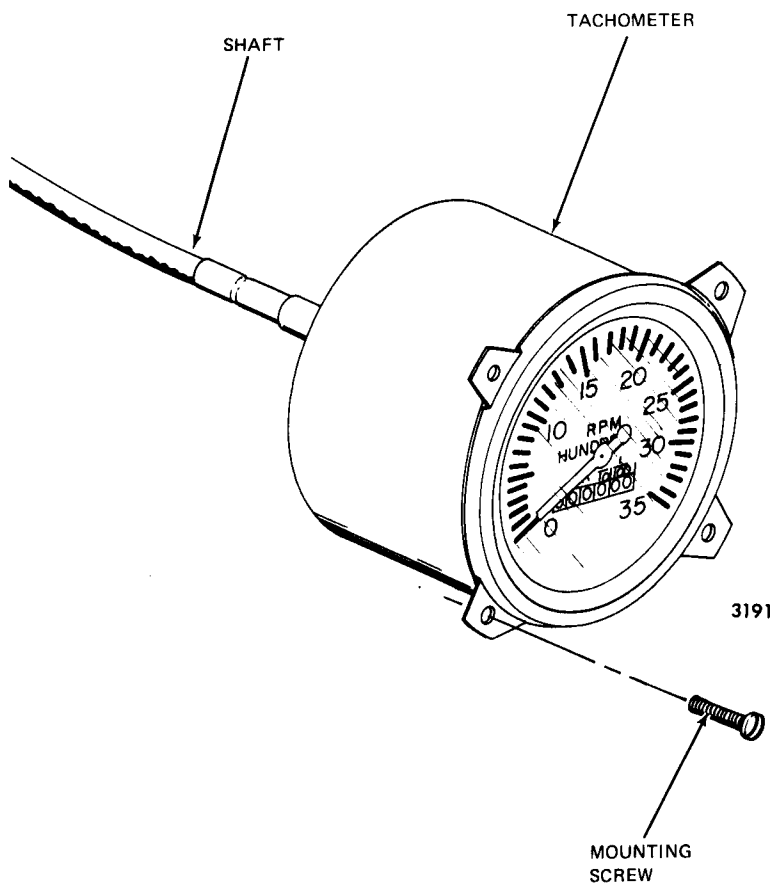

Tachometer
Figure 201

AA-5 SERIES
MAINTENANCE MANUAL

CHAPTER 78

EXHAUST

TABLE OF CONTENTS

| <u>NUMBER</u> | | <u>PAGE</u> |
|---------------|---|-------------|
| 78-0 | ENGINE EXHAUST SYSTEM | |
| | Description/Operation | 1 |
| | General | 1 |
| | Maintenance Practices | 201 |
| | Removal/Installation of Engine Exhaust System | 201 |
| | Inspection of Exhaust System | 204 |

**AA-5 SERIES
MAINTENANCE MANUAL**

ENGINE EXHAUST SYSTEM — DESCRIPTION/OPERATION

1. General

The exhaust system consists of an integral muffler and exhaust pipe, clamp assemblies, risers, and gaskets. The muffler is enclosed by a metal shroud which is connected by flexible tubing to the plenum assembly in the cabin and furnishes warm air for cabin heating. Inlet air is picked up through an opening in the front of the shroud which extends slightly through an opening in the front baffle.

On Model AA-5 and AA-5A aircraft, the carburetor heat hose is attached to a shell assembly around the exhaust pipe from No. 4 cylinder and supplies heat to the carburetor when the carburetor heat control is opened. On Model AA-5B aircraft, carburetor heat is supplied to the carburetor from a shroud around the muffler when the carburetor heat control is opened.

ENGINE EXHAUST SYSTEM - MAINTENANCE PRACTICES

1. Removal/Installation of Engine Exhaust System

A. Remove Exhaust System - Model AA-5 and AA-5A Aircraft (See Figure 201).

- (1) Remove the lower cowl (Refer to Chapter 71).
- (2) Remove the carburetor air induction system (Refer to Chapter 73).
- (3) Loosen clamps and disconnect cabin heater and fresh air inlet flexible ducts from muffler shroud assembly.
- (4) Loosen clamp and disconnect carburetor heat flexible duct from shell assembly around No. 4 exhaust pipe.
- (5) Remove nuts, bolts, and bead clamps from exhaust pipes, and lower muffler assembly from engine.
- (6) Remove nuts securing the exhaust risers to cylinders, and remove risers and gaskets.

B. Install Exhaust System - AA-5 and AA-5A Aircraft (See Figure 201)

- (1) Using new gaskets, position the risers on the cylinders and install the exhaust flange nuts loosely.
- (2) Position the muffler assembly on the risers; apply approved sealant (Walker Acousti-Seal 5160) around riser to muffler joints and install bead clamps.
- (3) Position support braces to bead clamps and install bolts loosely in bead clamps.
- (4) Tighten the exhaust flange nuts to 110-130 inch-pounds torque using new lock washers. Tighten bead clamp bolts.
- (5) Install cabin heater and fresh air inlet flexible ducts to muffler shroud assembly and tighten clamps.
- (6) Install carburetor heat flexible duct to shell assembly around No. 4 exhaust pipe and tighten clamp.
- (7) Install carburetor air induction system (Refer to Chapter 73).
- (8) Install the lower cowl (Refer to Chapter 71).

C. Remove Exhaust System - AA-5B Aircraft (See Figure 202)

- (1) Remove the lower cowl (Refer to Chapter 71).
- (2) Loosen clamps and disconnect cabin heater flexible duct and carburetor heat flexible duct from muffler shroud assembly.
- (3) Remove nuts, bolts, and bead clamps from exhaust pipes and lower muffler assembly from engine.
- (4) Remove nuts securing exhaust risers to cylinders, and remove risers and gaskets.

AA-5 SERIES
MAINTENANCE MANUAL

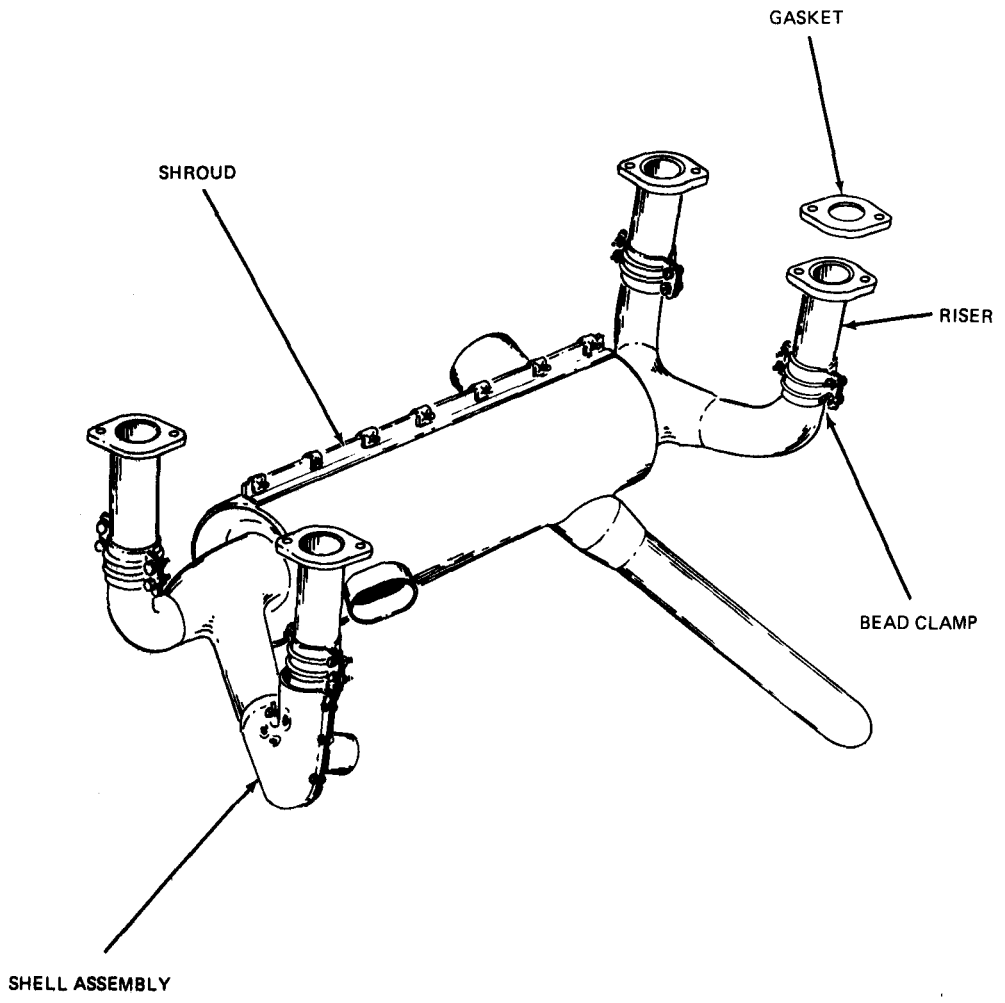

3191

Exhaust System Assembly - AA-5 and AA-5A
Figure 201

AA-5 SERIES
MAINTENANCE MANUAL

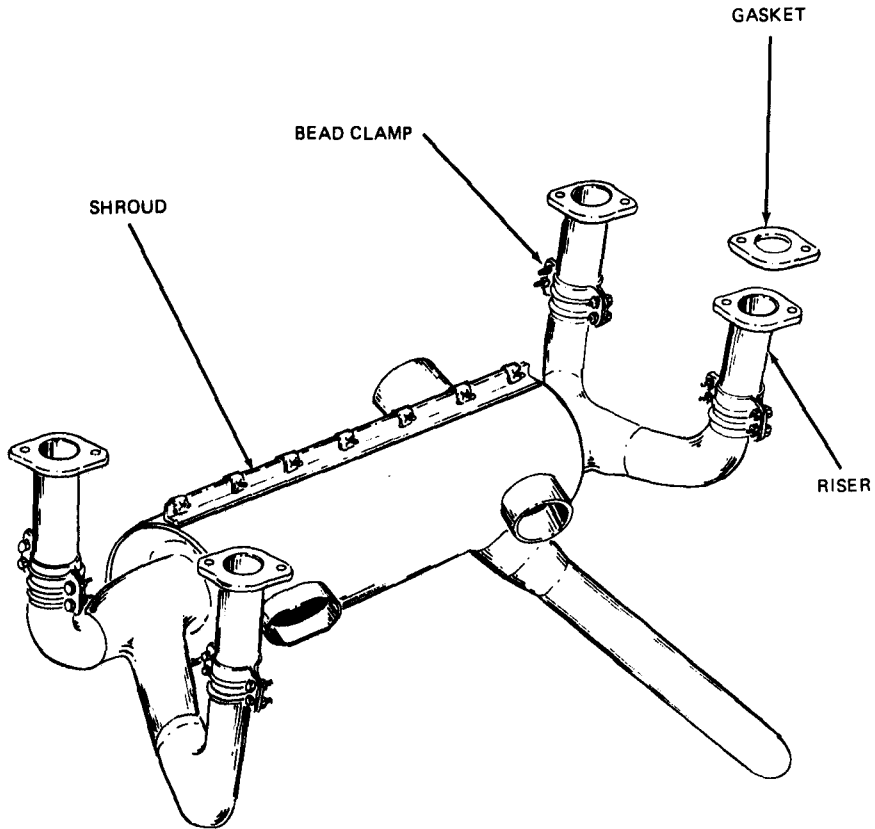

3192

Exhaust System Assembly AA-5B
Figure 202

**AA-5 SERIES
MAINTENANCE MANUAL**

D. Install Exhaust System - AA-5B Aircraft (See Figure 202)

- (1) Using new gaskets, position the risers on the cylinders and install the exhaust flange nuts loosely.
- (2) Position the muffler assembly on the risers; apply approved sealant (Walker Acousti-Seal 5160) around riser to muffler joints and install bead clamps.
- (3) Position support braces to bead clamps and install bolts loosely in bead clamps.
- (4) Tighten the exhaust flange nuts to 110-130 inch pounds torque using new washers. Tighten bead clamp bolts.
- (5) Install carburetor heat and cabin heater flexible ducts to the muffler shroud assembly and tighten clamps.
- (6) Install the lower cowl (Refer to Chapter 71).

2. Inspection of Exhaust System

Exhaust systems are subject to burning, cracking, and general deterioration from alternate thermal stresses and vibration. Consequently, it is extremely important that the system be inspected every 100 hours or at any time power loss is suspected or exhaust fumes or carbon monoxide are detected in the cabin. To properly inspect the exhaust system, the components must be clean and free from oil, grease, or dirt. Stoddard solvent may be used to clean exhaust system components.

WARNING: USE SOLVENTS IN A WELL VENTILATED AREA. AVOID BREATHING FUMES. KEEP AWAY FROM FLAMES.

WARNING: DO NOT USE HIGHLY FLAMMABLE SOLVENTS ON ENGINE EXHAUST SYSTEM. NEVER USE A WIRE BRUSH OR ABRASIVES TO CLEAN EXHAUST SYSTEMS OR MARK THE SYSTEM WITH LEAD PENCILS.

A. Inspect Exhaust System

- (1) Perform engine run up and check for required static RPM (Refer to Chapter 5-2-1)
- (2) Clean exhaust system components using a suitable solvent.
- (3) Allow components to drain and then wipe dry with a clean cloth.
- (4) Inspect core through tail pipe opening for distorted or deteriorated baffles and shake the muffler to determine if baffles are loose.
- (5) Tap muffler lightly with a rubber mallet and check for scale and rust from interior of muffler. Severely distorted, deteriorated or loose baffles, or large flakes of scale and rust from the interior of the muffler are an indication that the muffler should be replaced.

NOTE: Especially check the area adjacent to welds. Look for exhaust gas deposits in surrounding areas, indicating that exhaust gasses are escaping through a crack or hole. If thorough inspection is not possible, pressure test for leaks in accordance with AC43. 13-1, Chapter 14, Section 3, Paragraph 387B. If cracks are found in the muffler or tail pipe, repairs must be in accordance with AC43. 13-1, Chapter 14, Section 3, Paragraph 388.

- (6) Inspect the engine exhaust flanges for smooth seating surfaces. Check the header flanges for warpage.
- (7) Check fit of risers to muffler pipes. If loose, swage out the risers for tight fit.

**AA-5 SERIES
MAINTENANCE MANUAL**

- (8) Perform exhaust system air leak test as follows:
 - (a) Plug all openings in the muffler and attach the pressure side of an industrial vacuum cleaner (capable of producing a pressure rise of at least 2 inches Hg, above atmospheric pressure) to the tail pipe opening, using a rubber plug or other suitable means of effecting a suitable seal.

NOTE: The inside of the vacuum cleaner hose should be free of any contamination that might be blown into the system.
 - (b) With the vacuum cleaner operating, the complete muffler assembly can be checked for leaks by applying a soapy water solution to all areas and watching for air bubbles.
- (9) All leakage must be corrected.

AA-5 SERIES
MAINTENANCE MANUAL

CHAPTER 79

OIL

TABLE OF CONTENTS

| <u>NUMBER</u> | | <u>PAGE</u> |
|---------------|--|-------------|
| 79-0 | ENGINE OIL SYSTEM | |
| | Description/Operation | 1 |
| | General | 1 |
| | Trouble Shooting | 101 |
| | Maintenance Practices | 201 |
| | Oil Cooler Removal/Installation | 201 |
| | Oil Cooler Inspection | 201 |
| | Indicating Gages Removal/Installation | 201 |
| | Inspection and Maintenance of Flexible Hoses | 204 |

AA-5 SERIES
MAINTENANCE MANUAL

ENGINE OIL SYSTEM - DESCRIPTION/OPERATION

1. General

This chapter describes only those units and components of the oil system that are external to the engine. The components include: oil cooler, oil pressure gage, oil temperature gage, and associated wiring and tubing. An optional item is the oil filler access door for servicing, located on the right-hand side of the upper cowl.

The oil cooler is mounted on the left rear engine baffle. The cooler is connected to the engine accessory housing by flexible lines. Air to the cooler is picked up directly from the rear baffle.

The oil pressure gage and the oil temperature gage are mounted in the instrument cluster assembly, which is mounted on the upper right-hand side of the instrument panel.

AA-5 SERIES
MAINTENANCE MANUAL

ENGINE OIL SYSTEM - TROUBLE SHOOTING

1. Oil Cooler Trouble Shooting

| TROUBLE | PROBABLE CAUSE | REMEDY |
|-----------------------------|---|--|
| High Temperature indication | Obstructions in oil cooler air passages | Inspect oil cooler core for dirt or obstructions and clean as necessary. |

2. Oil Pressure Gauge Trouble Shooting

| TROUBLE | PROBABLE CAUSE | REMEDY |
|------------------------|---|--|
| No indication | Insufficient oil | Check oil supply and fill as recommended. |
| | Obstruction in pressure line | Remove all fittings and lines, starting at engine and inspect and clean as required. |
| | Defective gage | Replace gage |
| High or low indication | Defective gage | Replace gage |
| | Oil pressure relief valve out of adjustment | Check engine pressure with a calibrated gage and correct pressure setting as required. |

3. Oil Temperature Gage Troubleshooting

| TROUBLE | PROBABLE CAUSE | REMEDY |
|---------------------------------------|-------------------|---|
| No indication | Blown fuse | Replace with properly rated fuse. |
| No indication, high or low indication | Gage not grounded | Check gage ground connection and perform necessary repairs. |
| | Defective wiring | Check system with ohmmeter and perform necessary repairs. |
| | Defective gage | Repair gage |
| | Defective probe | Replace probe. |
| | Defective gage | Temporarily substitute a 28.5 ohm resistance for the probe. If gage does not read 245°F (Red Line), replace gage. |
| Low indication | Low voltage | Check voltage and adjust accordingly. |

ENGINE OIL SYSTEM - MAINTENANCE PRACTICES

1. Oil Cooler Removal/Installation

A. Remove Oil Cooler (See Figure 201)

- (1) Raise upper cowl to gain access.
- (2) Place a container under the oil cooler and disconnect flexible lines at oil cooler inlet and outlet fittings.
- (3) Cut safety wire on two mounting screws and remove screws, spacers, and washers.
- (4) Remove two nuts, screws, and washers securing cooler to engine baffle and remove reinforcing doublers and oil cooler.

B. Install Oil Cooler

- (1) Position reinforcing doublers and oil cooler in place on engine baffle and install washers, spacers, screws, and nuts.
- (2) Install safety wire in drilled screw heads.
- (3) Connect flexible lines at oil cooler inlet and outlet fittings.
- (4) Close cowl and operate engine for 3 minutes. Check cooler, flexible lines, and all connections for leakage.

2. Oil Cooler Inspection

A. Inspect Oil Cooler

- (1) Inspect oil cooler air passages for dirt and obstructions.
- (2) Inspect cooler core for cracks, damage and evidence of leakage.
- (3) Check flexible lines for worn or damaged areas and signs of leakage.

CAUTION: WHEN PERFORMING A SUBMERGED LEAK TEST ON THE OIL COOLER, DO NOT APPLY MORE THAN 100 PSI MAXIMUM.

- (4) If necessary to determine leakage, perform submerged leak test on oil cooler.

3. Indicating Gages Removal/Installation

A. Remove Oil Temperature and Oil Pressure Gages (See Figure 202)

NOTE: To remove the oil temperature and oil pressure gages the instrument cluster assembly must be removed.

- (1) To gain access, remove screws securing deck assembly to instrument panel. Raise deck assembly and tape to windshield.
- (2) Disconnect wiring from temperature gages at back of instrument cluster assembly.
- (3) Disconnect tubing from pressure gages at back of instrument cluster assembly.
- (4) Remove screws and nuts securing instrument cluster assembly to instrument panel and remove cluster assembly.

AA-5 SERIES
MAINTENANCE MANUAL

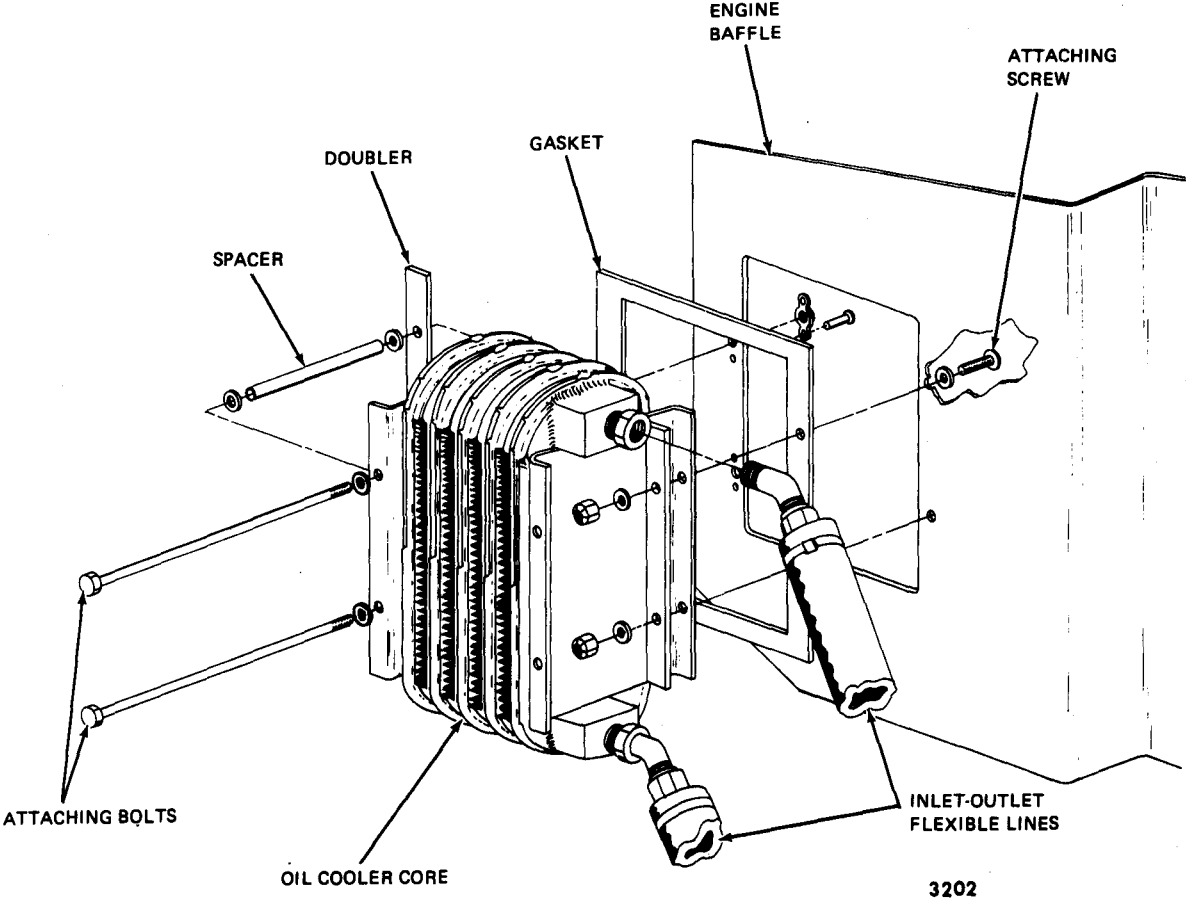

Oil Cooler Installation
Figure 201

AA-5 SERIES
MAINTENANCE MANUAL

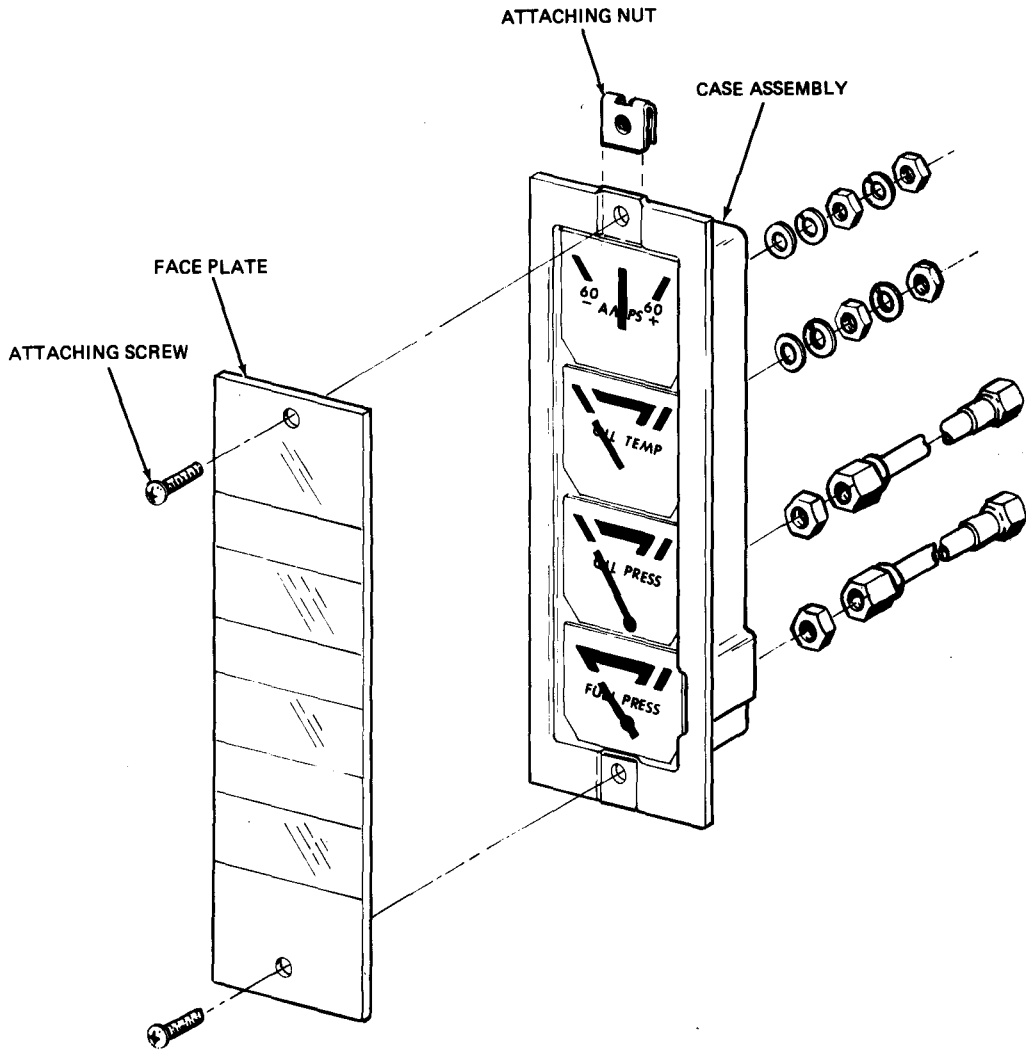

3310

Instrument Cluster Assembly
Figure 202

**AA-5 SERIES
MAINTENANCE MANUAL**

(5) Remove nuts and washers securing oil temperature gage to case and remove gage.

(6) Remove nut securing oil pressure gage to case and remove gage.

B. Install Oil Temperature and Oil Pressure Gages

(1) Position oil pressure gage in instrument cluster case and install nut on gage nipple.

(2) Position oil temperature gage in instrument cluster case and install washers and nuts on terminal studs.

(3) Position instrument cluster assembly to instrument panel and install attaching screws and nuts.

(4) Connect tubing to pressure gages at back of instrument panel.

(5) Connect wiring to temperature gages at back of instrument panel.

(6) Position deck assembly in place and install screws securing deck assembly to instrument panel.

4. Inspection and Maintenance of Flexible Hoses

A. Inspect Flexible Hoses

(1) Inspect flexible oil hoses at each 50-hour inspection.

(2) Examine flexible hose exterior for evidence of leakage.

CAUTION: AVOID EXCESSIVE FLEXING AND SHARP BENDS WHEN EXAMINING HOSES FOR STIFFNESS.

(3) Check flexible oil hoses for evidence of stiffness.

(4) Examine flexible oil hoses for evidence of rubbing or chafing.

B. Recommended Maintenance Procedures for Flexible Oil Hoses

(1) Replace all flexible oil hoses in the engine compartment at engine overhaul or every 5 years, whichever comes first.

(2) Replace all flexible oil hose that show evidence of leaking or stiffness.

(3) Avoid twisting the hose at installation.

(4) Provide as large a bend radius as possible at installation.

(5) At removal, do not attempt to straighten a flexible hose that has taken a permanent set during extended use in service.

(6) At reinstallation of flexible hose be sure that hose is returned to original position.

(7) Route hoses as far as possible from areas of intense heat.

(8) Refer to AC 43.13-1, Chapter 10, for flexible hose installation procedures.

**AA-5 SERIES
MAINTENANCE MANUAL**

CHAPTER 80

STARTING

TABLE OF CONTENTS

| <u>NUMBER</u> | | <u>PAGE</u> |
|---------------|--|-------------|
| 80-1-1 | STARTING SYSTEM | |
| | Description/Operation | 1 |
| | General | 1 |
| | Troubleshooting | 101 |
| | Maintenance Practices | 201 |
| | Removal/Installation of Starting System Components | 201 |

STARTING SYSTEM — DESCRIPTION/OPERATION

1. General

The starting system consists of the starter switch, starter relay, starter, a 5-amp fuse, and associated wiring necessary to effect the required connections. The starter switch is a pushbutton type switch located on the lower left-hand side of the instrument panel. The 5-amp fuse that protects the starter circuit is located at the extreme lower right-hand corner of the instrument panel. The same fuse also protects two other circuits and is decaled FUEL PUMP, STROBE, STARTER. The starter relay is located on the front of the firewall and is connected directly to the starter switch (See Figure 1). The starter is mounted on the front of the engine and is secured with one mounting bolt and three mounting studs, nuts, and washers. When power is supplied to the starter, the starter Bendix gears engage the starter ring gear mounted on the front end of the crankshaft and turn the engine for starting. Power for starting is supplied from a 12-volt, 25-ampere hour, dry-charge type battery.

AA-5 SERIES
MAINTENANCE MANUAL

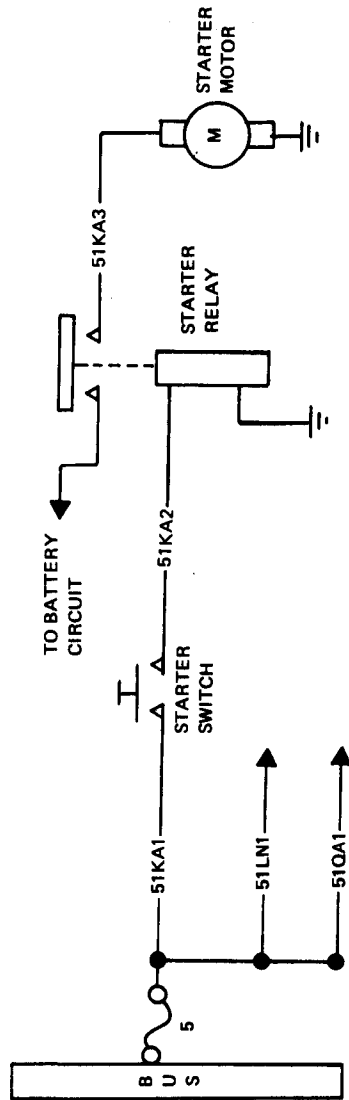

Starter Circuit
Figure 1

AA-5 SERIES
MAINTENANCE MANUAL

STARTING SYSTEM - TROUBLE SHOOTING

1. Trouble Shooting the Starter

| TROUBLE | PROBABLE CAUSE | REMEDY |
|--------------------------|---|---|
| Starter will not operate | Low Battery | Recharge or replace |
| | Blown fuse | Replace fuse |
| | Defective wiring | Check wiring with ohmmeter and repair as required. |
| | Defective starter relay | Replace relay |
| | Defective starter switch | With master switch off, conduct continuity test across starter switch. If circuit is open when button is depressed, replace switch. |
| | Defective starter motor | Repair or replace |
| Starter motor sluggish | Low battery | Recharge or replace |
| | Dirty contacts on starter switch or starter relay | Replace |
| | Defective starter | Repair or replace |
| | Dirty commutator | Clean and turn down as required. |
| Starter noisy | Worn starter drive gear | Inspect starter drive gear and replace if necessary |
| | Worn or broken teeth on crankshaft ring gear | Inspect crankshaft, ring gear and replace if necessary |

STARTING SYSTEM - MAINTENANCE PRACTICES

1. Removal/Installation of Starting System Components

A. Remove Starter (See Figure 201).

NOTE: Ensure that master switch is in OFF position.

- (1) Remove cowl as necessary to gain access to starter.
- (2) Disconnect starter cable and ground wire.
- (3) Remove bolt securing brace to alternator mount.
- (4) Remove mounting bolt and three nuts on starter mounting studs and remove starter.

B. Install Starter

- (1) Position starter on mounting studs and install nuts and mounting bolt.
- (2) Position brace from alternator mount in place and install mounting bolt.
- (3) Connect starter, cable and ground wire.
- (4) Install cowl.

C. Remove Starter Relay (See Figure 202.)

NOTE: Ensure that master switch is in OFF position.

- (1) Raise right-hand side of upper cowl to gain access.
- (2) Disconnect wiring from starter relay.
- (3) Remove bolts, nuts, and washers securing starter relay to firewall and remove relay.

D. Install Starter Relay

- (1) Position starter relay to firewall and install bolts, washers, and nuts.
- (2) Connect wiring to starter relay.
- (3) Close and secure cowl fasteners.

E. Remove Starter Switch

NOTE: Ensure that master switch is in OFF position.

- (1) Remove hex nut from shell of starter switch on front of instrument panel.
- (2) Push switch through panel and lower enough to disconnect wires from switch.

AA-5 SERIES
MAINTENANCE MANUAL

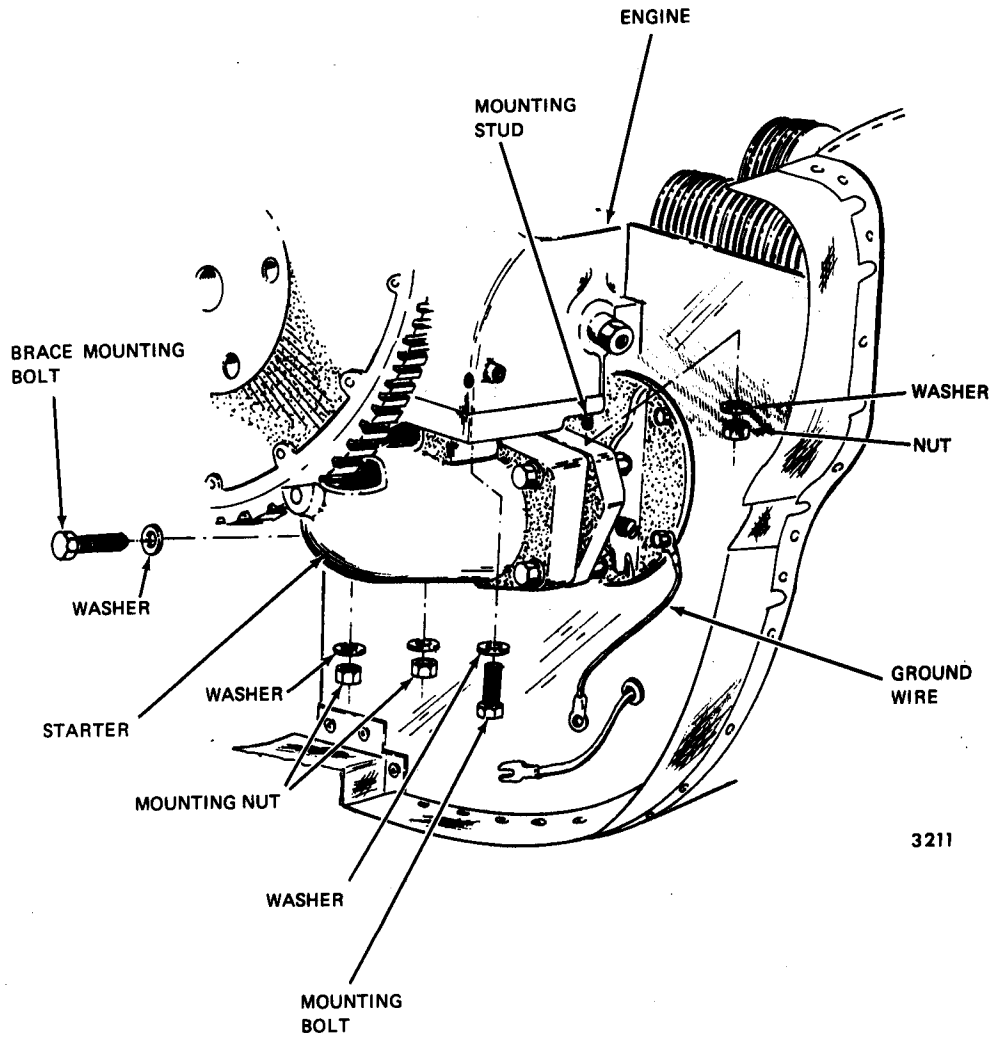

Starter Removal/Installation
Figure 201

AA-5 SERIES
MAINTENANCE MANUAL

F. Install Starter Switch

- (1) Connect wiring to starter switch.
- (2) Position switch in instrument panel and install hex nut on switch shell.

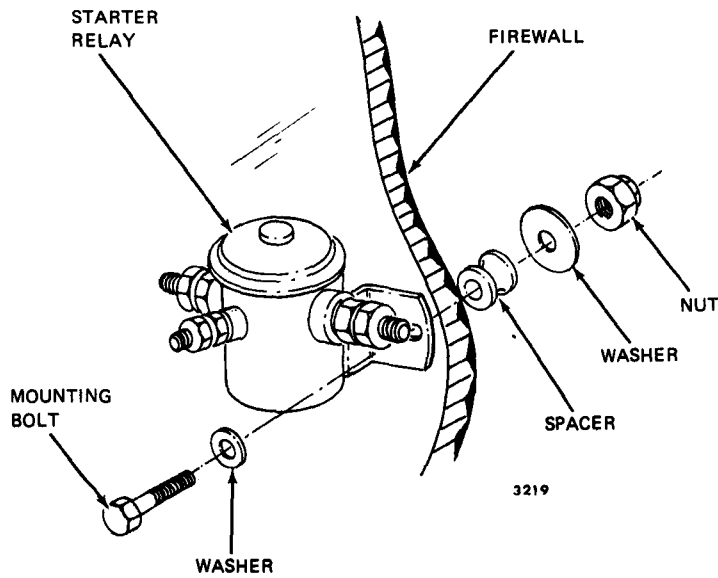

Starter Relay Removal/Installation
Figure 202

AA-5 SERIES
MAINTENANCE MANUAL

CHAPTER 91

CHARTS

TABLE OF CONTENTS

| <u>NUMBER</u> | | <u>PAGE</u> |
|---------------|-------------------------|-------------|
| 91-0 | CHARTS | |
| | Recommended Nut Torques | 1 |

**AA-5 SERIES
MAINTENANCE MANUAL**

RECOMMENDED NUT TORQUES

NOTE

The Torque Values stated are inch-pounds, related only to oil-free cadmium plated threads. All torque values given through out this service manual are for oil-free threads unless otherwise noted.

| FINE THREAD SERIES TYPE OF NUT | | | | |
|-----------------------------------|-----------------|-----------------|-----------------|-----------------|
| TAP SIZE | TENSION | | SHEAR | |
| | TORQUE | | TORQUE | |
| | STD (NOTE 1) | ALT (NOTE 2) | STD (NOTE 3) | ALT (NOTE 2) |
| | 8-36 | 12-15 | | 7-9 |
| 10-32 | 20-25 | 20-28 | 12-15 | 12-19 |
| 1/4-28 | 50-70 | 50-75 | 30-40 | 30-48 |
| 5/16-24 | 100-140 | 100-150 | 60-85 | 60-106 |
| 3/8-24 | 160-190 | 160-260 | 95-110 | 95-170 |
| 7/16-20 | 450-500 | 450-560 | 270-300 | 270-390 |
| 1/2-20 | 480-690 | 480-730 | 290-410 | 290-500 |
| 9/16-18 | 800-1000 | 800-1070 | 480-600 | 480-750 |
| 5/8-18 | 1100-1300 | 1100-1600 | 660-780 | 660-1060 |
| 3/4-16 | 2300-2500 | 2300-3350 | 1300-1500 | 1300-2200 |
| 7/8-14 | 2500-3000 | 2500-4650 | 1500-1800 | 1500-2900 |
| 1-14 | 3700-5500 | 3700-6650 | 2200-3300 | 2200-4400 |
| 1-1/8-12 | 5000-7000 | 5000-10000 | 3000-4200 | 3000-6300 |
| 1-1/4-12 | 9000-11000 | 9000-16700 | 5400-6600 | 5400-10000 |

COARSE THREAD SERIES

| | (NOTE 4) | (NOTE 5) | |
|---------|-----------|-----------|-----|
| | 8-32 | 12-15 | 7-9 |
| 10-24 | 20-25 | 12-15 | |
| 1/4-20 | 40-50 | 25-30 | |
| 5/16-18 | 80-90 | 48-55 | |
| 3/8-16 | 160-185 | 95-100 | |
| 7/16-14 | 235-255 | 140-155 | |
| 1/2-13 | 400-480 | 240-290 | |
| 9/16-12 | 500-700 | 300-420 | |
| 5/8-11 | 700-900 | 420-540 | |
| 3/4-10 | 1150-1600 | 700-950 | |
| 7/8-9 | 2200-3000 | 1300-1800 | |
| 1-8 | 3700-5000 | 2200-3000 | |
| 1-1/8-8 | 5500-6500 | 3300-4000 | |
| 1-1/4-8 | 6500-8000 | 4000-5000 | |

AA-5 SERIES
MAINTENANCE MANUAL

NOTES

1. Covers AN310, AN316, AN345, AN363, AN366, MS20365, "1452", "EB", "UWN", "Z1200", and other self-locking nuts.
2. When using AN310 or AN320 castellated nuts where alignment between bolt and cotter pin is not reached using normal torque values, use alternate torque values or replace nut.
3. Covers AN316, AN320, AN7502 and MS20364.
4. Covers AN310, AN340, AN366, MS20365, and other self-locking anchor nuts.
5. Covers AN316, AN320 and MS20364.

The above values are recommended for all installation procedures contained in this manual except where other values are stipulated. They are not to be used for checking tightness of installed parts during service.